

Architectural Collection
2024/2025 — Versatile, controlled,
efficient and connective solutions
integrated into the architecture, as
well as environmentally friendly.
These are the core features of the
Indoor, Outdoor and Emergency
lines, unique and modular designs
adaptable to all projects.

LedsC4

Indoor

N

New product
Produit nouveauté

E

Essential product
Produit essentiel

Indoor Collections

Atom 040



Track
078



Low Voltage
114

N



Surface
291

N



Surface Double
291



Hide
300

N



Recessed
306

Iris 048

N



Track Spotlight
086



Track Pendant
268



Low Voltage
Spotlight
120



Low Voltage
Pendant
120



Low Voltage
Downlight
120



Pendant Recessed
268



Pendant Surface
268



Ceiling
274



Spotlight Recessed
274



Spotlight Surface
274

Bento 060



Low Voltage
126



Low Voltage Wall
Washer
126



Standard
232



Adjustable
239



IP Recessed
241



Wall Washer
243



N

Low Voltage
Adjustable
126



Surface
309



IP66 Surface
309

Kiva 072



Low Voltage
118



N

Surface
312









N

Recessed
312

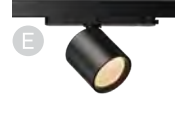













Spotlights / Tracks
Projecteurs / Rails

076

Atom  Track 078	Iris  Track Spotlight 086	 Track Pendant 086	Tak  088	Strom  092	Play  Track 096	Track  097
------------------------------------------------------------------------------------------------------------------	----------------------------------------------------------------------------------------------------------------------------	-----------------------------------------------------------------------------------------------------------	--------------------------------------------------------------------------------------------------------	-----------------------------------------------------------------------------------------------------------	--------------------------------------------------------------------------------------------------------------------	------------------------------------------------------------------------------------------------------------











Low Voltage
Basse Tension

108

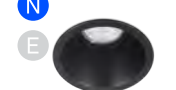
Atom  114	Kiva  118	Iris  Spotlight 120	 Pendant 120	 Downlight 120	Tango  124	Bento  126
Bento  Wall Washer 126	Kiva  Adjustable 126	Infinite  132	On  130	Nara  128	Track  Standard 134	Bento  Hyperlink 138

Downlights

172

Nit  174	Veo  178	Vol  182	Play  184	Lite  220	Dome  229	Ges  230
Bento  232	Multidir Evo  247	Totem  250	Ecofit  255			

Pendants
Suspensions

260

Pek	Luno Slim	Iris	Play
			
262	264	268	271





Spotlights / Ceilings
Projecteurs / Plafonniers

272

Iris	Leco	Luno Slim	Ges	Play
				
Ceiling 274	278	279	282	Deco 283
				
Spot Surface 283				
Exit	Mutidir Evo	Atom		
				
284	285	291	291	300
				
306				
Bento	Kiva			
				
309	IP66 311	313	314	

Lineal light systems
Systèmes d'éclairage linéaires

316

Apex	Infinite Pro	Infinite Slim	Lineal	Taglio di Luce
				
318	338	366	376	378

N
New product
Produit nouveauté

E
Essential product
Produit essentiel

Click



400

Bat



403

Secret



409

Step



410

LED Strips

Bandeaux à LED

Asai

N

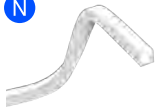

412

On

E



420

Outdoor

N
New product
Produit nouveauté







E
Essential product
Produit essentiel

Outdoor Collections

Eko
436
N

				
Spotlight 550	Downlight 608	Bollard 744	Wall Fixture 794	Ceiling 856

Max
440

					
Spotlight 540	Downlight 598	Uplight 630	Bollard 738	Wall Fixture 788	Ceiling 852

Modis
450
N

				
Spotlight 553	Bollard 706	Lampost 706	Wall Fixture 782	Ceiling 862

Orbit
458
N

			
Bollard 718	Lampost 718	Rechargeable 884	Plug & Play 884

Rack
466

			
Wall Fixture 823	Rechargeable 892	Plug & Play 892	Bollard 892

Lineal light systems
Systèmes d'éclairage linéaires

476

Taglio System

N



Surface Fix
489

N



Surface Adjustable
490

N



Wall
490

N



Recessed
491

Vercle



496



496

Asai

N



504

Mex



Surface
508



Recessed
508

Convert

E



Surface
513

E



Recessed
513

Cube Linear

N



Surface
518

N



Recessed
518

Projectors
Projecteurs

528

Cube



530

Max



540

Eko

N



550

Modis



553

Hubble



Cob
560



GU10 Aluminium
565



GU10 Technopolymer
566

Thor



568

Micro



572

Zoom



576

Suv

E



582

Helio

E



AISI316 GU10
583

E



Aluminium GU10
583

E



Aluminium E27
583

Underwater
Submersibles

584

Aro

N



586

N



586

Aqua

E



Spotlight GU5.3
594



Spotlight LED
594



Recessed GU5.3
594



Recessed LED
594





Recessed downlights
Encastrés de plafond

596

Max	Dako	Eko	Gea
			
598	604	608	LED 610













Recessed wall lights
Encastrés de mur

611

Click	Micenas	Bat	Tiny	Arc
				
612	615	618	624	627

Recessed floor lights
Encastrés de sol

628

Max	Gea					
						
630	Pro 646	Cob 653	Wall Washer 656	Compact 658	Signaling 660	Technopolymer 662
Kay	los	Rim		Pixel	Xena	
						
666	Symetrical 668	Asymetrical 668	674	678	682	

Surface uplights
Encastrés de surface

684

Path	Xena	Rexel	Soul
			
686	690	692	694

N
New product
Produit nouveauté

E
Essential product
Produit essentiel

Bollards / Lampost
Balises / Réverbères

698

Ele

N



Bollard
702

N



Lampost
702

Modis

N



Bollard
706

N



Lampost
706

Helion



Bollard
714



Lampost
714

Orbit

N



Bollard
718



Lampost
718

Lyon

N



Bollard
726



Lampost
726

Juncus



Bollard
730



Lampost
730

Invisible



734

Max



738

Eko

N



744

Rek



747

Newton



LED Pro
754



LED
754



E27
754

Dan

E



760

Row



764

Simenti



766

Diago



768

Cubik



LED
769



E27
769

Priap



772

Nott



773

Grid

E



774

Citizen



775

Proud



776

Zigzag



778

Wall Fixtures

Appliques

780

Modis



782

Max



788

Eko

N



794

Cosmos



798

Afrodita

N



Infinite
804



Tech
806

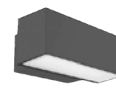

LED
808

Nemesis

N

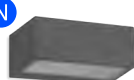

814

Wilson

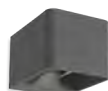

816

Clous



818

Simenti



819

Diago



819

Power LED
810

GU10
812

Finestra

N



RGBW DMX
820

N



Standard
820

Rack



823



823

Moal



826

Decorative lighting wall lights

Appliques d'éclairage décoratif

Arc



828

Sam



830

Kossel

E



Indirect
834



Direct
834

Transit area wall lights

Appliques de zones de passage

Skat



837

Curie

E



841

Darwin



844

Basic

E



Aluminium
845

Mega



869

Direct lighting wall lights

Appliques d'éclairage direct

N

New product
Produit nouveauté

E

Essential product
Produit essentiel

Ceilings
Plafonniers

850

Max



852

Eko

N



856

Cosmos



858

Modis

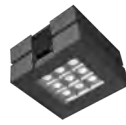

862

Afrodita

E



868

Mega



869

Kössel



872

Soul

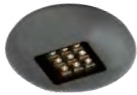

694

Bento IP66



ID
873

Basic

E



845

Chillout

874

Sinia

N



876

Orbit

N



Rechargeable
884

N



Plug & Play
884

Rack



Rechargeable
892



Plug & Play
892



Bollard
892



Wall Fixture
892

Moal



904

Barcino

N



907

Cisne

E



Pendant
910

E



Surface
910

Easy Safe Garden

914

Zoom

N



920

Gea Technopolymer

N



920

Cisne

N



921















Orbit

N

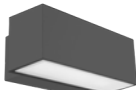

921

Emergency Lighting

Redo		Deco		Flag	Star	Line
						
930	Surface 932	933	Track 939	938	938	940
Leco	Play	Infinite Pro	Vol	Bento	Veo	Afodita
						
941	942	953	962	959	964	961
Ecofit						
						
966						



New product
Produit nouveauté



Essential product
Produit essentiel

Smart Lighting

D4i



970

DALI2



972

Bluetooth Casambi



974

DMX



977

Standalone



979

Light for better living

Quality light enhances
the spaces it illuminates
La lumière de qualité
améliore les espaces
qu'elle éclaire

Quality light enhances the spaces it illuminates, stirs emotions and changes the perception of a space, shaping it with its silent presence. Good light accompanies and looks after you, enhances well-being and improves people's quality of life.

Our lighting culture is our passion for exploring its possibilities, understanding it, creating it and experiencing it, and this ambition is reflected in our solutions that strike the optimal balance between quality, design, technology, service and care for the environment.

We have more than 50 years of experience manufacturing and designing lighting products and offering a comprehensive service for all phases of very diverse lighting projects, both indoor and outdoor, to make quality light as easy as possible.

La lumière de qualité améliore les espaces qu'elle éclaire, provoque des émotions et change la perception d'un espace, le façonnant avec sa présence silencieuse. La bonne lumière accompagne et protège, contribue au bien-être et améliore la qualité de vie des personnes.

Notre culture de la lumière se traduit par la passion pour explorer ses possibilités, la comprendre, l'expérimenter et créer de solutions offrant le meilleur équilibre entre qualité, design, technologie, service et respect de l'environnement.

Nous avons plus de 50 ans d'expérience dans la fabrication et la conception de produits et l'offre d'un service d'accompagnement dans toutes les phases d'éclairage d'un large éventail de projets, à l'intérieur et à l'extérieur, pour rendre l'éclairage de qualité aussi facile que possible.





Design, quality and technology

Design, qualité et technologie

Our solutions are developed by technical and decorative lighting experts, who work to achieve the highest quality standards.

LedsC4 technicians and engineers collaborate with lighting designers, landscapers and interior designers from the conceptualisation of the product to the mechanical engineering for its installation, through to the volumetric and technological design, the selection of materials and the modelling; all of this following eco-design criteria with a view to ensuring maximum energy efficiency and the recyclability of the products and their components.

Nos solutions sont créées par des experts en éclairage technique et décoratif qui travaillent en suivant des critères de qualité stricts.

Les techniciens et ingénieurs de LedsC4 collaborent avec des designers et des concepteurs d'éclairage, internes et externes, pour développer depuis la conceptualisation du produit jusqu'à l'ingénierie mécanique de son installation, en passant par le design volumétrique et technologique, la sélection des matériaux et le modelage, le tout en suivant des critères d'éco-conception qui recherchent l'efficacité énergétique maximale et la recyclabilité du produit et de ses composants.

The designers we work evolve our portfolio with their personal approach to lighting, sharing our passion and how we understand it.

Les designers complètent notre portefeuille avec leur vision personnelle de la lumière, en partageant notre passion et la manière de la comprendre.

Technology for advanced and efficient lighting

Une technologie pour un éclairage de pointe et efficace

Our history and experience in lighting allows us to offer advanced, efficient lighting solutions developed by our innovation departments, with digital services and control and connectivity technology.

Notre parcours et notre expérience en éclairage nous permettent de proposer des solutions d'éclairage de pointe et efficaces, conçues par nos départements d'innovation, avec des services numériques et une technologie de contrôle et de connectivité.

Control and connectivity

Contrôle et connectivité

75% of our catalogue
is connective
75 % de notre catalogue
est connectif

Continuous innovation

Innovation continue

Providing you with controlled
and efficient solutions
Nous proposons de solutions
contrôlées et efficaces







We consider all processes

Nous veillons sur l'ensemble des processus

We painstakingly consider all processes, from development to design, manufacturing and quality testing, to delivery and installation, offering at all times a fast, effective and easy service.

We have a production centre in Torà and a Design and Innovation Centre in Madrid, which specialises in devising retail and integrative solutions that meet quality demands and adapt to the circadian rhythm to ensure people's well-being in different settings.

Nous veillons minutieusement sur l'ensemble des processus, du développement à la livraison et à l'installation, en passant par la conception, la fabrication et les tests de qualité, en offrant un service rapide, efficace et facile.

Nous disposons d'un centre de production à Torà et d'un centre de conception et d'innovation à Madrid, spécialisé dans la vente au détail et les solutions intégrées qui répondent à la demande de qualité et d'adaptation au rythme circadien pour le bien-être des personnes dans différentes applications.



The LedsC4 lighting experience

We assist you with your idea
Nous vous aidons à concrétiser
votre idée



We support you throughout the life cycle of your installation so that you get maximum performance in terms of comfort and energy efficiency. Nous vous accompagnons tout au long du cycle de vie de votre installation, afin que vous en tiriez le meilleur parti en termes de confort et d'efficacité énergétique.

Consulting and advice

Conseil et assistance

- Lighting project
Projet d'éclairage
- Control proposal
Proposition de contrôle
- Architectural proposal
Proposition architecturale
- Energy-saving study
Étude des économies d'énergie
- Electrical diagrams
Schémas électriques
- Special luminaire design
Design de luminaires spéciaux
- Sound absorption study
Étude d'absorption acoustique

Quarterly support plans

Plans d'accompagnement trimestriels

Quarterly service covering everything from adjusting scenes or setting hourly programmes to checking the system and sensors.

Servicio trimestral que incluye desde, Reajuste de escenas o Programaciones horarias hasta comprobación del sistema y sensores.

- **Plan Basic**
Remote support
Accompagnement à distance
- **Plan Performance**
On-site support
Acompañamiento In Situ

Project management

Technical assistance

Gestion du projet

Assistance technique

Ready to:

Configuration and pre-commissioning of control and connectivity equipment at the factory.

Configuration et pré-mise en service des équipements de contrôle et de connectivité en usine.

On site:

On-site advice and configuration of lighting and control equipment.

Conseil et configuration des équipements d'éclairage et de contrôle sur site.

- Service
Intervention
- Advice
Conseil
- Commissioning
Mise en service
- Optimisation
Optimisation
- Training
Formation

Sustainability and social commitment

Durabilité et engagement social

Looking after and protecting our surrounding area, with the aim of generating a positive impact, is one of the missions we work towards as part of our daily activity

Préserver notre environnement, le respecter, ayant pour but de générer un impact positif, est l'un des objectifs de notre quotidien



We're bidding farewell to 2023 with:
Nous achevons 2023 avec :

- 98% fixed-employment contracts
98 % de contrats fixes
- More than 90% of luminaires are now segregable and come with a replaceable LED and driver
Plus de 90 % de luminaires sont séparables et avec des LED et des drivers remplaçables
- 28,300 kg less cardboard and 505 kg less plastic in packaging
Une réduction de 28.300 kg de carton et de 505 kg d'emballages en plastique
- EPD Environmental Declaration Certificate
Certification de déclaration environnementale EPD
- EcoVadis Gold Medal in Sustainability
Médaille d'or d'EcoVadis en matière de durabilité



Our roadmap for 2026 is:
Notre feuille de route pour 2026 est la suivante :

- 100% staff trained in good environmental practices
100 % du personnel formé aux bonnes pratiques environnementales
- 100% sustainable packaging
100 % de packaging durable
- 60% dimmable luminaires
60 % de luminaires réglables
- 95% segregable luminaires
95 % de luminaires séparables
- 65% of luminaires built with recyclable material
65 % des luminaires fabriqués avec un matériau recyclable
- 15% reduction in carbon footprint
15 % de réduction de l'empreinte carbone
- Photovoltaic panels installed in the main production centres
Installation de plaques photovoltaïques dans les principaux centres de production
- 30% of models should have an environmental certification
30 % des références ont une certification environnementale



Brand Corner



350 M\$



15
Production
sites
Sites de
production



2000
Employees
Employés



+140
Countries with
LedsC4 projects
Pays avec des projets
LedsC4

www.brandcorner.es

LedsC4 is part of Brand Corner industrial group, a dynamic family business group founded in 1987 with a large international presence and global business vision.

Brand Corner has an international team of more than 2,000 professionals developing projects all over the world, bringing together companies in a wide range of sectors including lighting, furniture, construction, household appliances, packaging, security systems, sanitary equipment, gas and oil, plastic injection moulding and cardboard.

LedsC4 appartient au groupe industriel Brand Corner, une entreprise dynamique au noyau familial et entrepreneurial fondée en 1987, qui a une large présence internationale et une vision commerciale globale.

Brand Corner s'appuie sur une équipe internationale de plus de 2 000 professionnels qui développent des projets dans le monde entier, réunissant des entreprises qui opèrent dans des secteurs aussi divers que l'éclairage, le mobilier, la construction, le petit électroménager, le packaging, les systèmes de sécurité, les équipements sanitaires, le gaz et le pétrole, l'injection plastique et l'emballage.

LedsC4

boyer
barcelona lights

CARANDINI®

HORMIPRESA

Coveright

VILAGRASA

Resol

plasfur

CVmédica®

Condulados
ARME, S.L.

FIGUERAS

b&b
trends

precintia

SCHMITZ | WILA

INDOX



Smart Lighting

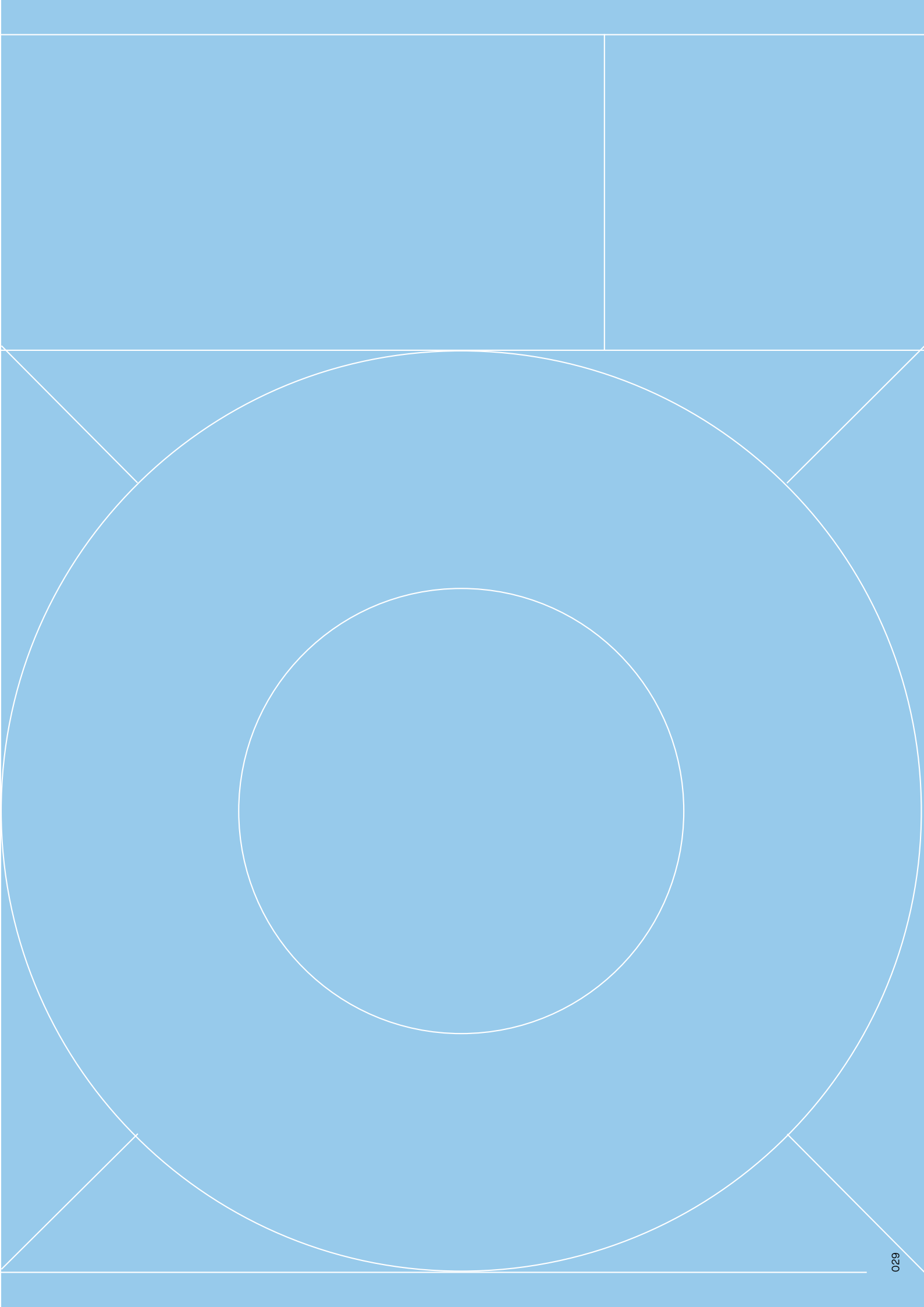

Smart lighting solutions

Solutions d'éclairage intelligent

We adapt to any lighting need, regardless of the space, in order to offer unique solutions and bring the benefits of control and connectivity to our customers.

Nous répondons à n'importe quel besoin d'éclairage, quel que soit l'espace, pour pouvoir offrir à nos clients des solutions uniques et leur faire bénéficier des atouts du contrôle et de la connectivité.



Light ambiances and well-being Ambiances lumineuses et bien-être

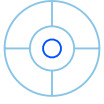

With a lighting control system and the option of adjusting the luminaires' intensity or colour temperature (Tunable White), the space is more flexible and dynamic, meaning it can adapt to changing needs.

Avec un système de contrôle de l'éclairage et la possibilité de varier l'intensité ou la température de couleur des luminaires (Tunable White), l'espace gagne en flexibilité et en dynamisme pour s'adapter à l'évolution des besoins.



Brondesbury Park Synagogue, London 2022.

A wide variety of luminaires that use the Casambi control system to create different atmospheres depending on the use of the space and the festivities.

Vaste éventail de luminaires qui, avec un système de contrôle Casambi, génèrent différentes atmosphères en fonction de l'utilisation de l'espace et des festivités.

CNTEC, Girona 2020.

Finelight DALI controlled via a DALI2 system that allows maximum flexibility in the space depending on use.

Finelight Luminaires DALI contrôlés par un système DALI2 qui permet une flexibilité maximale de l'espace en fonction de l'utilisation.

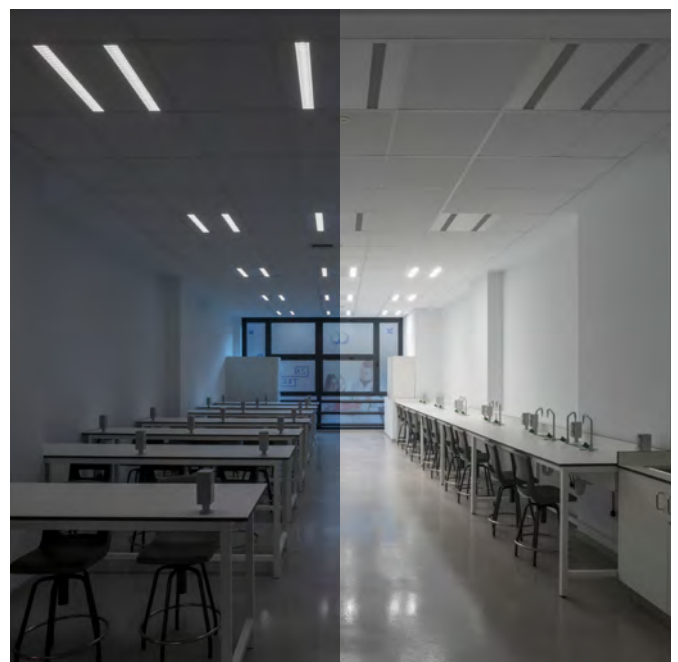

Colour management Gestion de la couleur



Colour is the best vehicle for conveying emotions. A colourful space is capable of generating sensations and making the people found in it feel certain emotions. Providing spaces with colour makes them more flexible, as they can change according to the communication goal or the installation's context, all by using a LedsC4 control system.

La couleur est le meilleur vecteur de transmission d'émotions. Un espace coloré est capable de générer des sensations et de faire ressentir des émotions aux personnes qui s'y trouvent. Doter les espaces de couleur les rend plus flexibles, en leur permettant de changer en fonction de l'objectif de communication ou du contexte de l'installation, le tout grâce à un système de contrôle de LedsC4.



Llum BCN, Barcelona 2022.

Special luminaires with Casambi Ready technology that allow the ideal colour to be selected for the project.

Luminaires spéciaux avec technologie Casambi Ready qui permettent de sélectionner la couleur idéale pour le projet.

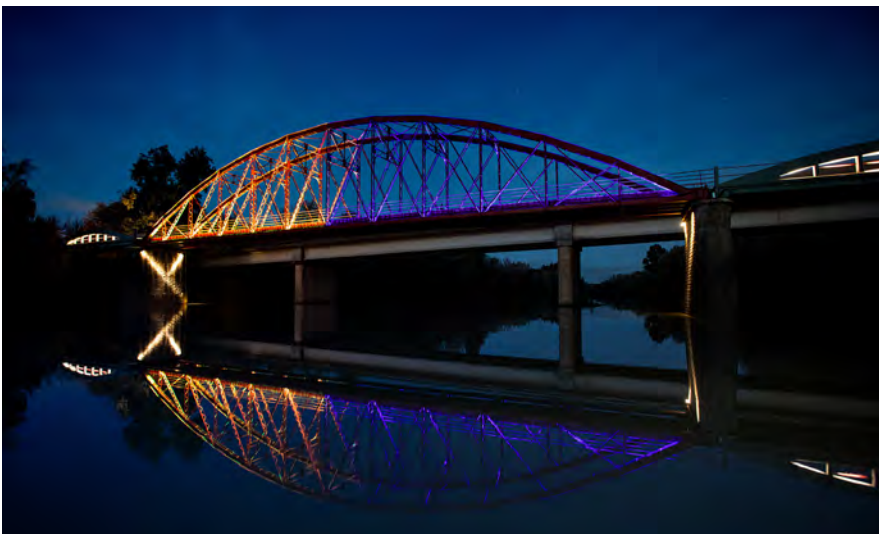

Puente de los Remedios, Villafranca de Cordoba 2022.

LedsC4 lighting and DMX control project. Thanks to our on-site service, LedsC4 technicians were able to provide support during the different phases of the project and set up the lighting to achieve different scenes depending on the time and occasion of the year.

Projet d'éclairage et de contrôle DMX de LedsC4. Grâce au service On site, des techniciens de LedsC4 ont conseillé pendant les différentes phases du projet et ont configuré l'éclairage pour obtenir différentes scènes en fonction des festivités de l'année.

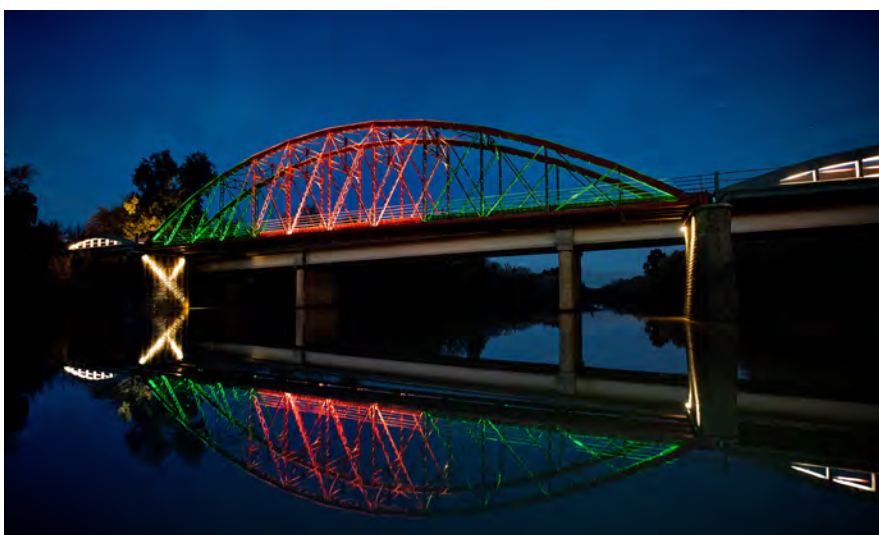

Energy saving Économies d'énergie

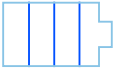

A reduction in energy consumption is achieved thanks to the pairing of efficient lighting and a control system. Systems that allow data to be collected and energy-saving strategies to be implemented based on occupancy and improved use of natural light and the available resources.

La réduction de la consommation d'énergie s'obtient en alliant éclairage efficace et système de contrôle. Grâce à des dispositifs qui permettent de recueillir des données et d'établir des stratégies d'économie en fonction de l'occupation, ainsi que de mieux tirer parti de la lumière naturelle et des ressources disponibles.



Iberspa, 2022.
Casambi lighting control. Daytime slot / Night-time slot.
Contrôle de l'éclairage Casambi. Plage horaire de jour / Plage horaire de nuit.

Energy-saving strategies

Stratégies d'économies d'énergie

- Dimmable and adjustable lighting according to people's or the situation's needs. Savings of up to 20%
Éclairage variable et réglable en fonction des besoins de la personne ou de la situation. Jusqu'à 20 % d'économies
- Control via occupancy. Switch-on with several levels of adjustment based on occupancy or absence. Savings of up to 30%
Contrôle par l'occupation. Allumage de plusieurs niveaux de variation en fonction de l'occupation ou de l'absence. Jusqu'à 30 % d'économies
- Adjustment via constant light control based on the entry of natural light. Savings of up to 30%
Réglage par contrôle de lumière constante en fonction de l'apport de lumière naturelle. Jusqu'à 30 % d'économies

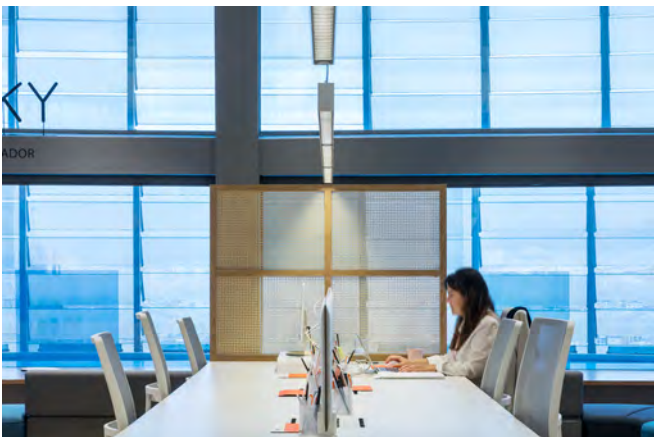

Loom, Barcelona 2020-2022.
Illumination control D41i. Intensity 80%. Scene with occupation. Intensity 25%. Scene without occupation.
Contrôle de l'éclairage D41i. Intensité 80%. Scène avec occupation. Intensité 25%. Scène inoccupée.

Space management

Gestion de l'espace

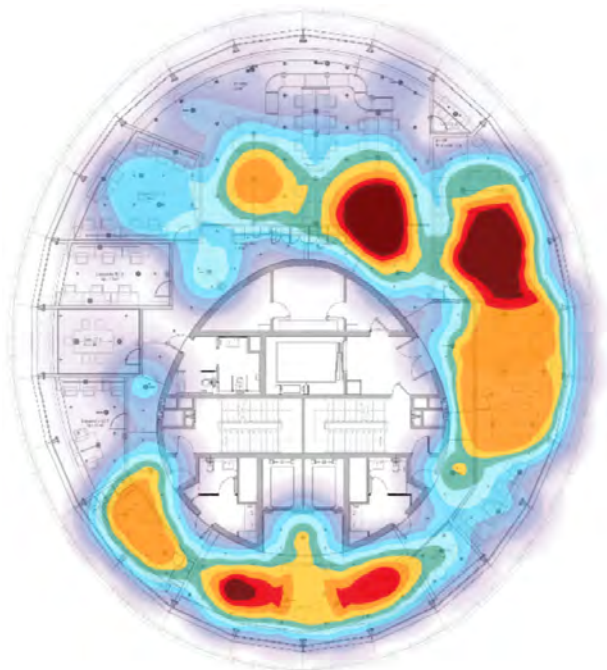

To increase the efficiency of an installation and thereby the business, use of a space must be managed and controlled. Pour accroître l'efficacité d'une installation et donc de l'entreprise, il est essentiel de gérer et de contrôler l'utilisation de l'espace.

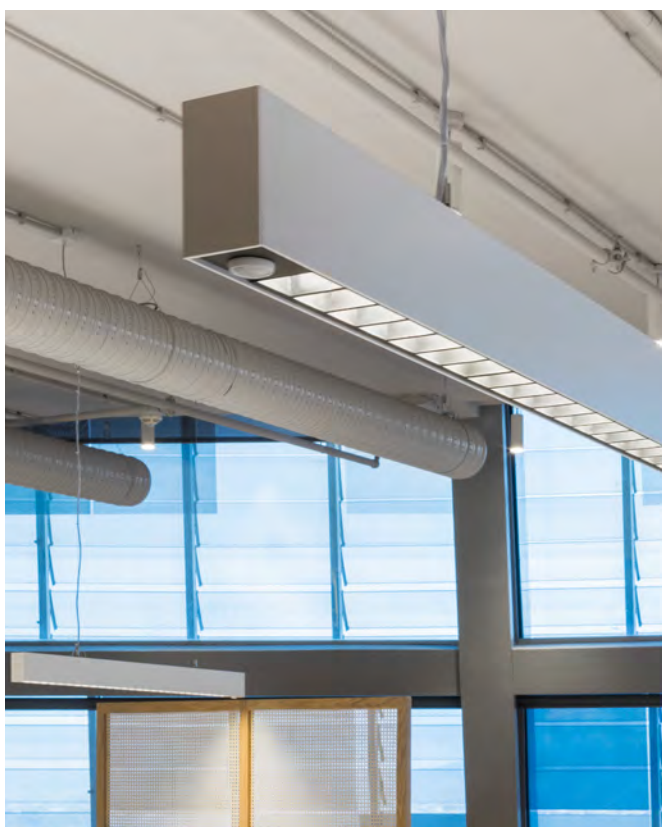

Infinite Pro with D4i sensor that captures information on the use of the space.

Infinite Pro avec capteur D4i capable de capter des informations de l'utilisation de l'espace.

Strategies to manage spaces:

Stratégies de gestion de l'espace :

- Obtaining heat maps to find out which areas are more or less frequently used
Obtenir des cartes thermiques pour identifier les zones plus ou moins fréquentées
- Viewing the most-used routes and user movements
Rendre visibles les circuits les plus utilisés et les déplacements des utilisateurs
- Information about the conditions in workstations
Connaître l'état des postes de travail

These strategies allow the following:

Ces stratégies permettent de :

- Make the most of an organisation's space and determine real needs
Tirer le meilleur parti des espaces d'une organisation et déterminer les besoins réels
- Find out users' habits
Connaître les habitudes des utilisateurs
- Adopt communication campaigns or strategies based on the most-used areas
Adopter des campagnes ou stratégies de communication en fonction des zones les plus fréquentées

Preventive maintenance

Entretien préventif

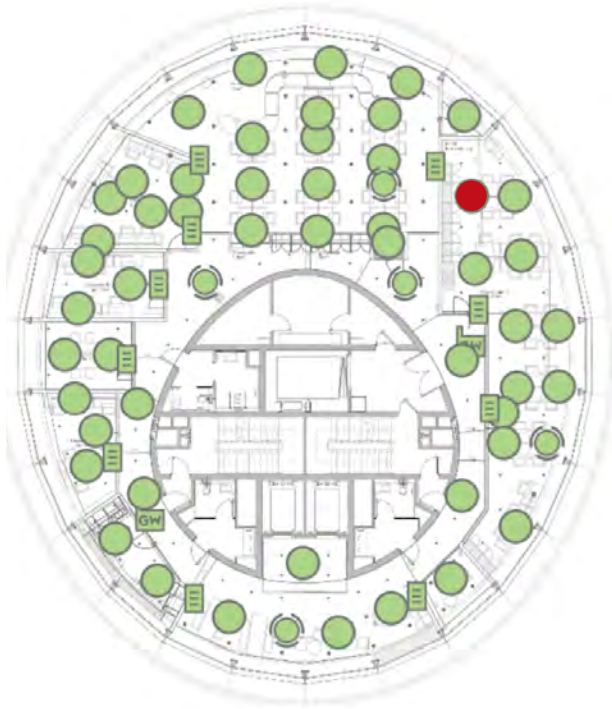

Actively monitoring the information provided by luminaires allows you to understand the luminaires' condition and longevity, as well as detect incidents and conduct checks on equipment and installations to guarantee proper operation and upcoming maintenance.

Un suivi actif des informations obtenues à partir des luminaires nous permet de connaître l'état et la durabilité de ces derniers, de détecter des incidents et d'effectuer des révisions des dispositifs et installations dans le but de garantir un bon fonctionnement et une bonne conservation future.

CNTEC, Girona 2020.

Study centre for centralised control of the entire space, making it possible to learn the condition of the luminaires.

Centre d'études, où l'on recherche un contrôle centralisé de l'ensemble de l'espace, permettant de connaître l'état des luminaires.

Photographer / Photographe: Jordi Anguera



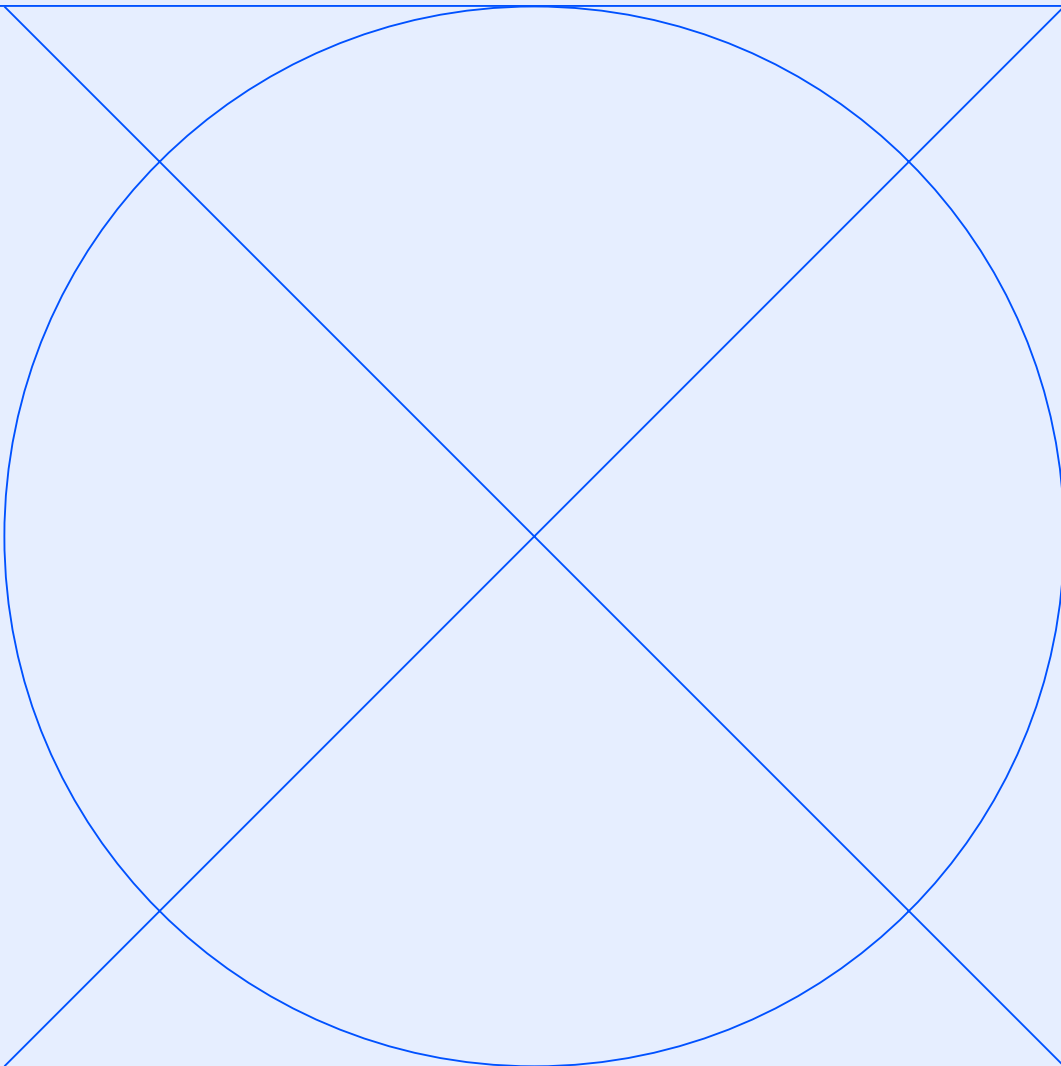

Indoor



038
Indoor
Collections



076
Spotlights / Tracks
Projecteurs / Rails

LV

108
Low Voltage
Basse Tension



172
Downlights



260
Pendants
Suspensions



272
Spotlights/ Ceilings
Projecteurs / Plafonniers

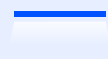

316
Lineal Light Systems
Systèmes d'Éclairage
Linéaires



398
Signalling
Signalisation



411
LED Strips
Bandeaux à LED

Indoor Collections

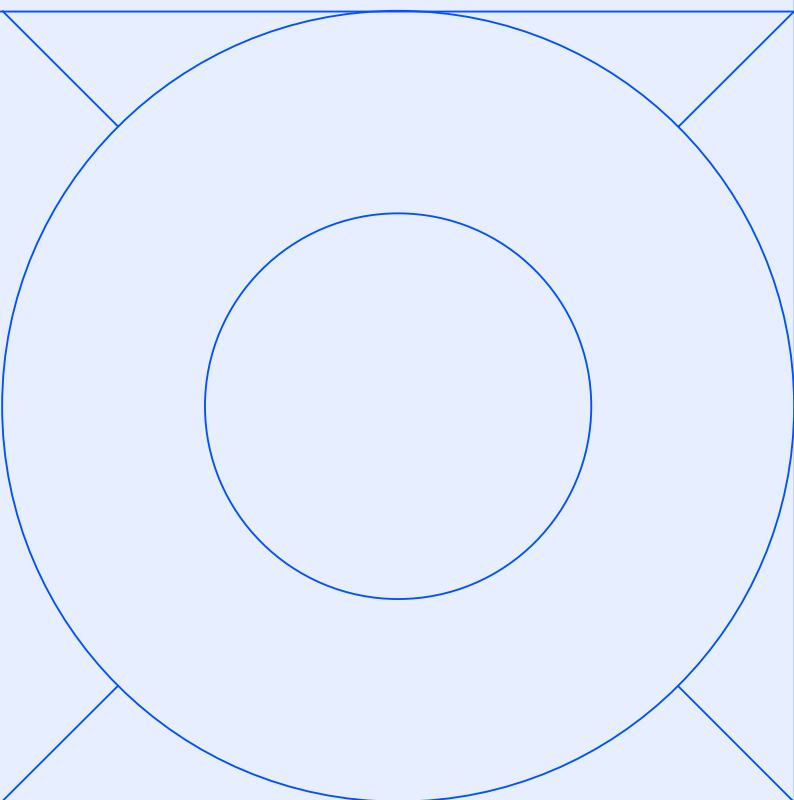

Atom

040

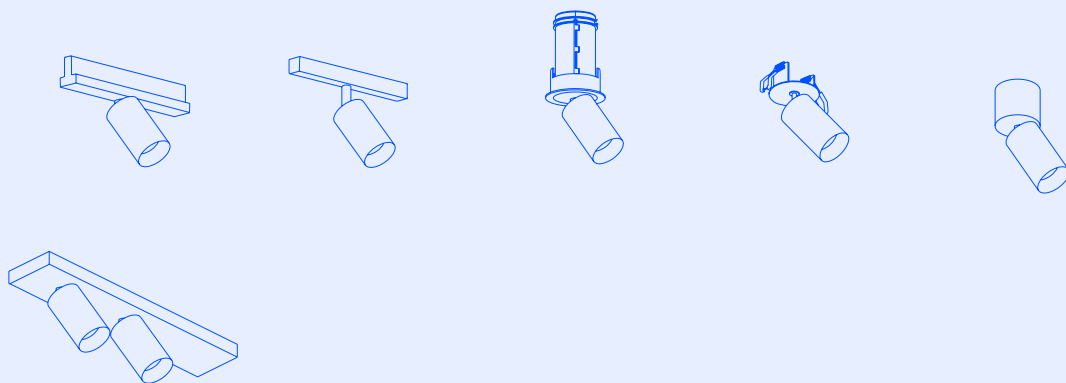

Iris

048

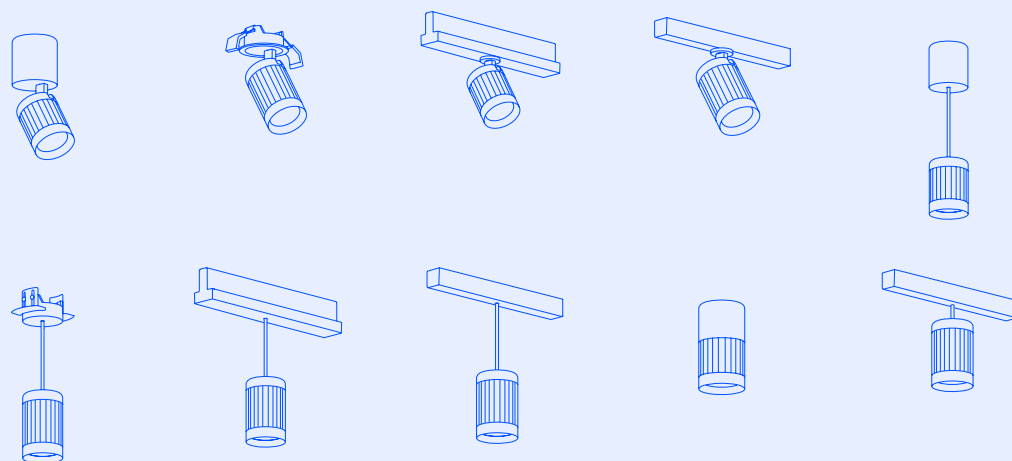

Bento

060

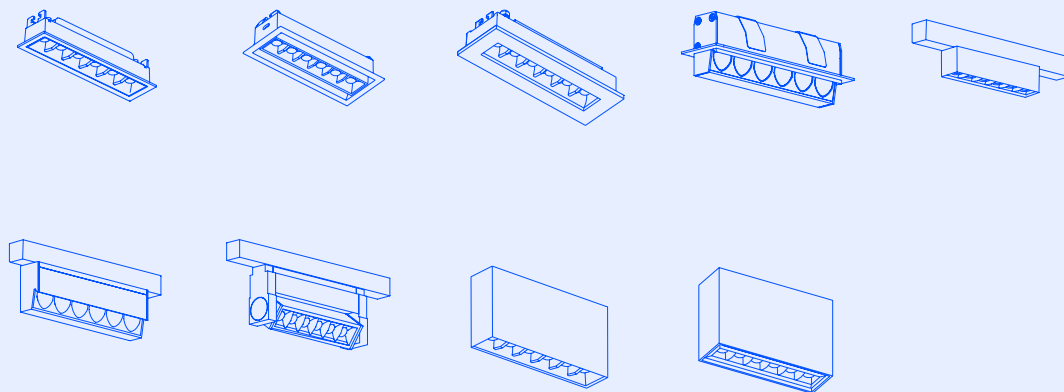

Kiva

072



Atom

Designed by LedsC4 Architectural



+ Atom

Track
P. 078



Low Voltage
P. 112



Spotlight
P. 306



Spotlight
P. 291



Spotlight
P. 300



Cylindrical design and harmonic proportions Design cylindrique et proportions harmonieuses

Atom's versatility is such that its size and finish can be adapted to each environment, respecting the harmony of the space. Its technical solutions provide optimal control over the entire range of angles, ensuring high visual comfort.

Atom est si polyvalent qu'il peut adapter sa taille et sa finition à chaque décor, en respectant l'harmonie de l'espace. Ses solutions techniques permettent un contrôle optimal de toute la gamme d'angles, garantissant un haut degré de confort visuel.



Spotlight
Atom Surface
291

Spotlight
Atom Hide
300

Spotlight
Atom Recessed
306

Track
Atom Track
078

Low Voltage
Atom Low Voltage
112

Ø 30 mm

Ø 30 mm

Ø 30 mm



○ ●
14 60

○ ● ○ ●
14 60 81 DN

○ ●
14 60

Ø 52 mm

Ø 52 mm

Ø 52 mm

Ø 52 mm

Ø 52 mm



○ ● ○ ●
14 60 81 DN

○ ● ○ ●
14 60 81 DN

○ ● ○ ●
14 60 81 DN

○ ●
14 60

○ ● ○ ●
14 60 81 DN



○ ●
14 60

Ø 75 mm

Ø 75 mm

Ø 75 mm



○ ●
14 60

○ ●
14 60

○ ●
14 60

Ø 97 mm



○ ●
14 60

7.5 - 38W

3.1 - 24W

3.1 - 12.1W

7.5 - 46.8W

3.1 - 15W



Ultraspot 8° -
Ultraflood 47°

Ultraspot 8° -
Ultraflood 47°

Ultraspot 8° -
Ultraflood 47°

Ultraspot 8° -
Ultraflood 49°

Ultraspot 8° -
Ultraflood 47°





Different installation options in the
same collection
Différentes options d'installation
dans une même collection

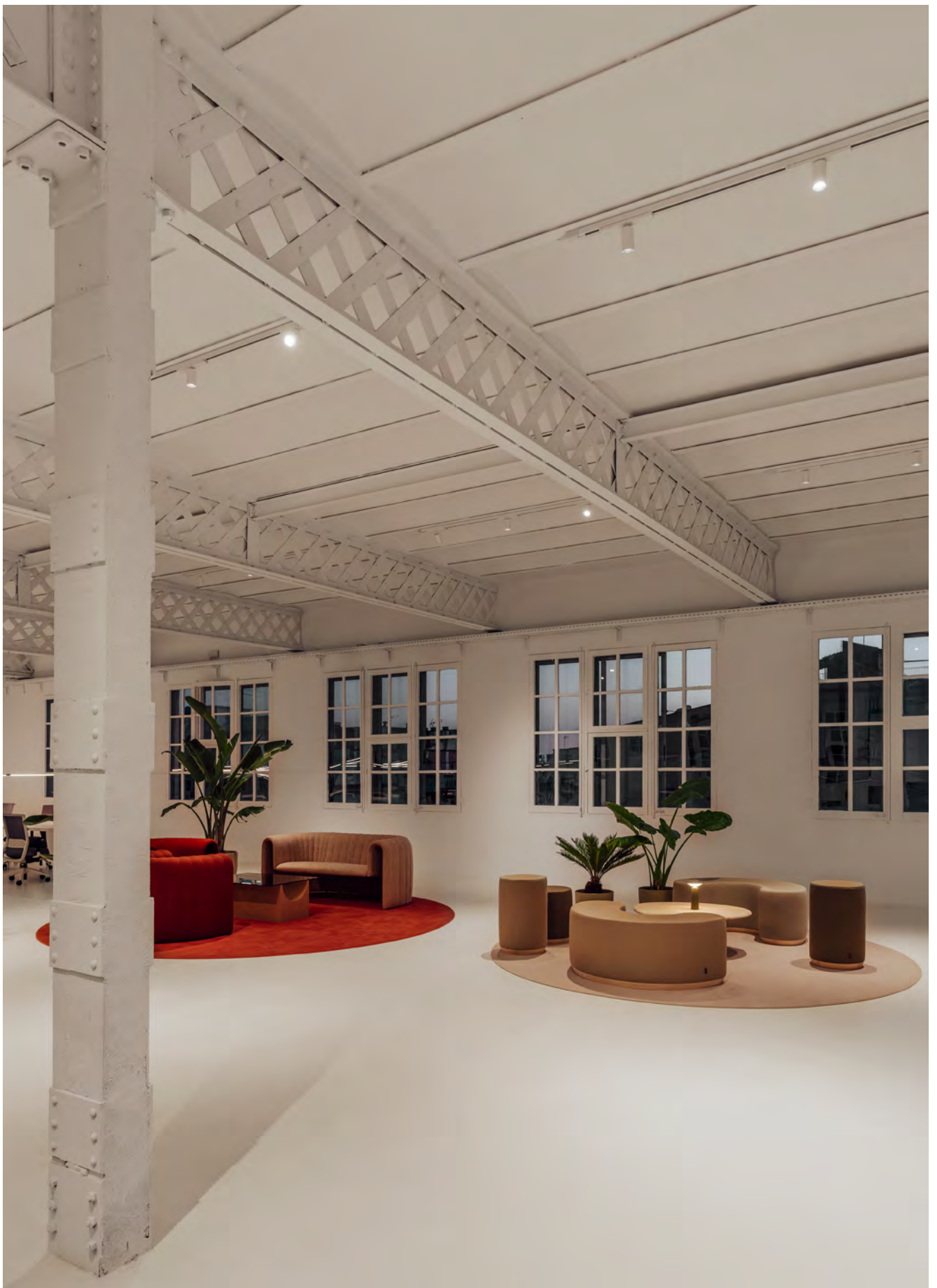

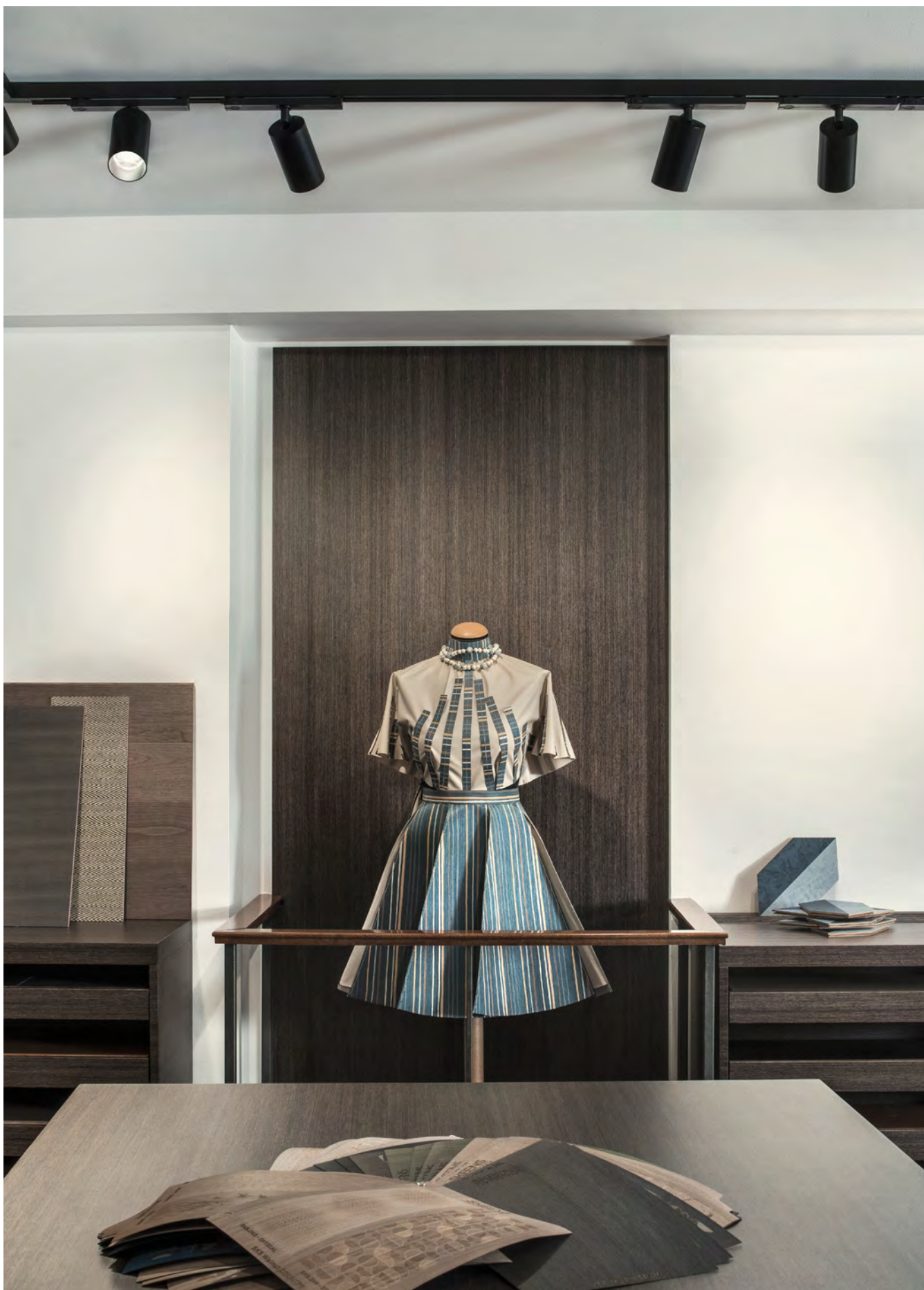

Tabu Studio project. Milan. Product used: Atom Track 75. Photographer: Germano Borrelli.
Projet Estudio Tabú. Milan. Produit utilisé: Atom Track 75. Photographe: Germano Borrelli.





Atom Low Voltage on private residence in Barcelona. Architecture: aaa Barcelona by Ignacio Infiesta. Photography: Javier Márquez.
Atom Low Voltage sur résidence privée à Barcelone. Architecture : aaa Barcelona par Ignacio Infiesta. Photographie : Javier Márquez.



Iris

Designed by Artec Studio



+ Iris

Spotlight
P. 086

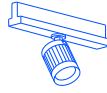

Low Voltage
P. 120



Pendant
P. 268



Ceiling
P. 274



Spotlight Surf.
P. 274



Both architectural and decorative, Iris is an organic and living collection, which generates dialogue by creating different environments and improving them with its presence through light and the visual effect evoked by its structure. Its endless composition possibilities and adaptiveness to the space form a perfectly harmonious circle of creation.

Architecturale et décorative à la fois, Iris est une collection organique et vivante, qui dialogue activement en créant différents environnements et en les mettant en valeur par sa présence à travers la lumière et la perception visuelle de sa structure. Ses possibilités d'adaptation à l'espace et de composition sont si vastes qu'elles forment un cercle de création en parfaite harmonie.



Just as the eye iris widens and contracts to adapt to the light, Iris modulates its body and soul to adapt to the spaces it inhabits, improving them

Tout comme l'iris de l'œil qui se dilate et se contracte pour s'adapter à la lumière, Iris module son corps et son âme pour s'adapter aux espaces qu'elle habite et les améliorer

3-Phase Track

086

Low Voltage Track

120

Ceiling Surface

274

Ceiling Remote Driver

274

INDOOR

INDOOR COLLECTIONS

Spotlight

AV21



AV19



AV13 / AV28



AV11 / AV12
Trim/Trimless



Fixed

AV23



AV17 / AV27



Pendant

AV25



AV24



AV16 / AV26 P. 268



AV14 / AV15 P. 268
Trim/Trimless



Finishings / Finitions

Selection of finishes available on the online configurator.
Sélection de finitions disponibles grâce au configurateur en ligne



Configurator
Configurateur
iris.ledsc4.com

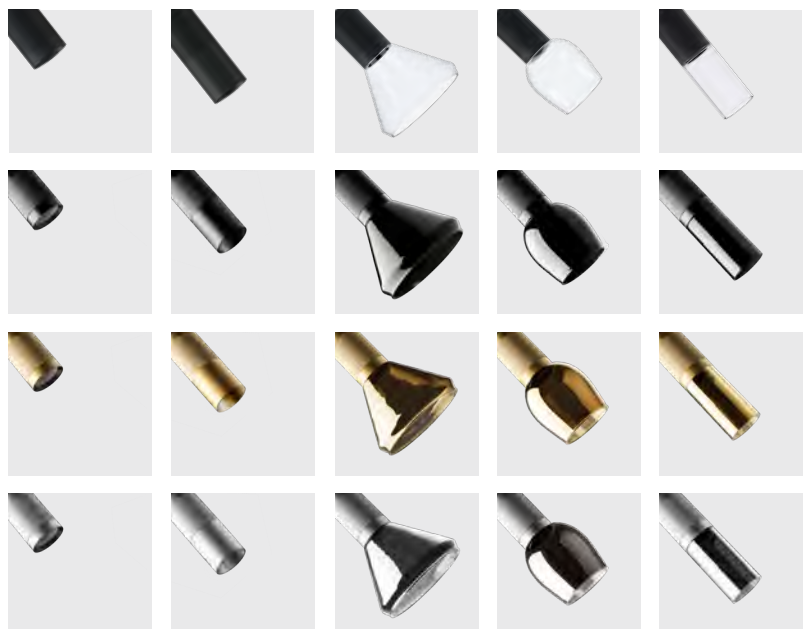

049



Soul with character. Iris' different lenses make it possible to shape the light according to the needs of the space, to highlight products or create comforting, cosy areas.

Âme et caractère. Les différentes optiques d'Iris permettent de façonner sa lumière en fonction des besoins de l'espace, pour mettre en valeur des produits ou générer des zones de confort et de chaleur.



The perfect balance between functionality, quality and warmth. Thanks to the different combinations of glass, finishes and compositions, Iris' light is able to arouse feelings, making it ideal for corporate settings where perception and emotions are the basis of communication.

Équilibre parfait entre fonctionnalité, qualité et chaleur. Grâce aux différentes combinaisons de verres, de finitions et de compositions, la lumière d'Iris génère des sensations, c'est pourquoi elle est idéale pour les espaces d'entreprise où la perception et les émotions sont à la base de la communication.



Chromatic quality and visual comfort. Accessories and components such as visual comfort make up this highly technical piece that enhances the colour ranges of the products it illuminates with a CRI90, so it's particularly suited to settings such as art galleries or concept stores.

Qualité chromatique et confort visuel. Les accessoires et les composants tels que le confort visuel constituent une pièce hautement technique capable de renforcer la gamme de couleurs des produits qu'elle éclaire avec un IRC90, ce qui rend son utilisation parfaitement adaptée aux espaces tels que les galeries d'art ou les concept stores.



The magic of glass La magie du verre



Insinuating transparency when
turned on.
Transparence insinuante lorsqu'il
est activé.

Iris conveys feelings both switched on and off. The special texture of the glass components, blown with a special treatment, creates a mirror effect when turned off and suggestive transparencies when the light bounces off the diffuser.

Allumée comme éteinte, Iris transmet des sensations. La texture particulière des composants en verre, soufflés avec un traitement spécial, provoque un effet miroir lorsque la lumière est éteinte et des transparences suggestives lorsqu'elle est renvoyée par le diffuseur.



Mirror effect when turned off.
Effet miroir lorsqu'il est éteint.

Harmony in the space Harmonie dans l'espace

Chameleon-like and suggestive. Iris features special components, all of which have a different personality based on their body and soul, which are the light and shapes of the pieces. The perception of the luminaires varies depending on where they are seen from or the reflection of natural light on the surface.

Caméléonesque et évocatrice. Les composants d'Iris sont spéciaux et tous possèdent une personnalité différente en fonction de leur corps et âme, constitués par la lumière et par leurs formes. La perception varie selon le point d'observation ou l'incidence de la lumière naturelle sur leur surface.



Precision Précision

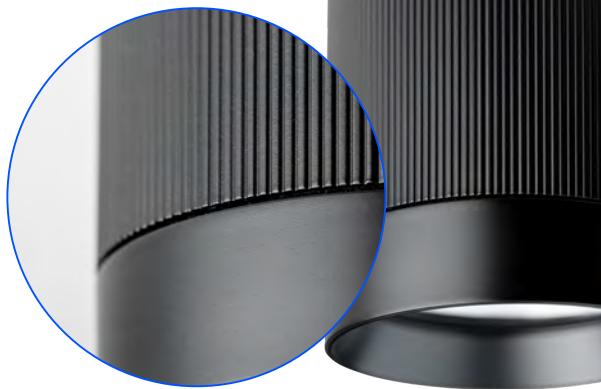

Iris is developed in a factory using the grafilat technique, a high-tech artisanal marking method. The entire process is carried out with meticulous attention to detail.
L'élaboration d'Iris se fait en usine grâce à la technique grafilat, qui consiste en un marquage artisanal d'une haute technicité. L'ensemble du processus est développé avec un soin particulier pour les détails.

Sustainable product Produit durable



Energy Efficiency Efficacité énergétique

The piece's composition promotes heat dissipation and allows you to adjust consumption by adjusting the brightness.

La composition de la pièce favorise la dissipation de la chaleur et permet d'ajuster la consommation en réglant l'intensité lumineuse.

Recyclable Material Matériau recyclable

Made of recyclable products and/or products from recyclable sources.

Utilisation de produits recyclables et/ou issus de sources recyclables.

Sustainable Design Conception durable

Easily changeable LED module and control mechanism to extend the product's lifespan.
Remplacement facile du module LED et du mécanisme de contrôle pour augmenter la durée de vie utile du produit.

Waste separation Tri des déchets

Iris's components can be disassembled to easily sort waste.
Iris permet le démontage des composants pour faciliter la gestion des déchets.

This includes using recyclable materials, with replaceable components that have a high degree of durability
Utilisation de matériaux recyclables, avec des composants remplaçables et un degré de durabilité élevé





Different compositions in the same collection
Différentes compositions dans la même collection

Iris configurator

Configurateur Iris



iris.ledsc4.com

INDOOR

INDOOR COLLECTIONS

Infinite configuration options in a quick and easy way thanks to our online configurator.

Une infinité d'options de configuration de manière simple et rapide grâce à notre configurateur en ligne.

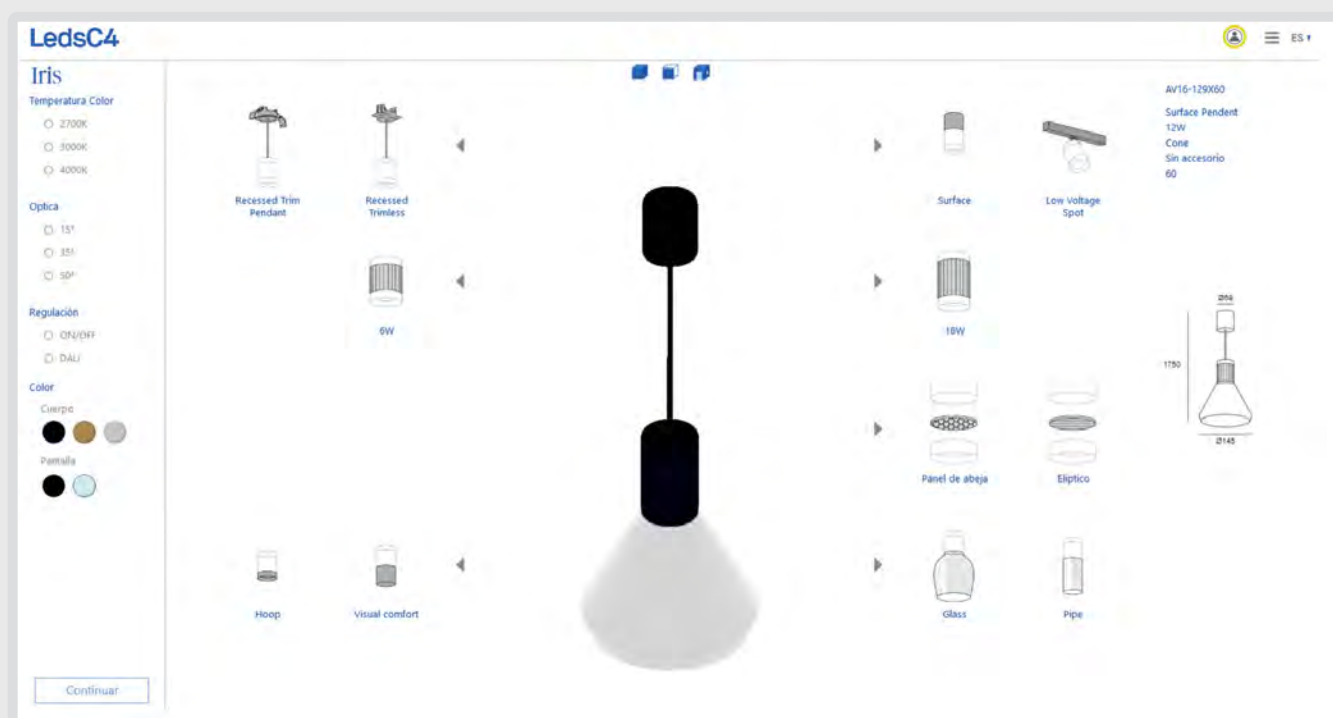

1 Select properties, installation, finishes, accessories and components
Sélectionnez les propriétés, l'installation, finitions, accessoires et composants

2 Documentation download
Télécharger de la documentation

059

Bento

Designed by LedsC4 Architectural

Downlights
P. 232



Ceilings
P. 309



Low Voltage
P. 126

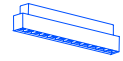

+ Bento



Lens system designed with high-definition micro-reflectors that conceal the light source

Système optique conçu avec des micro-réflecteurs haute définition qui masquent la source lumineuse

The lenses in this collection of downlights are specially developed to avoid glares and achieve optimal control of the luminaire in demanding situations. Featuring a multi-cell structure and individual lens modules, Bento is the ideal choice for environments where comfort and integration are the foremost concern.

Le groupe optique de cette collection de downlights est spécialement conçu pour éviter l'éblouissement et obtenir un contrôle optimal du luminaire dans les situations exigeantes. Avec sa structure multicellulaire et ses modules optiques individuels, Bento est l'option idéale pour les environnements qui nécessitent un maximum de confort et d'intégration.





Downlights
Bento

233

94 mm



Downlights
Bento Adjustable

239

106 mm



Spotlights / Ceilings
Bento Surface

309

84 mm



Downlights
Bento IP65

241

117 mm



173 mm



186 mm



163 mm



197 mm



332 mm



322 mm



491 mm



100 mm



7.8 - 15.4W



Spot 15° - Ultra Flood 50°
Trim



14-14 60-60 14-60

Trimless



14-14 14-60

7.8 - 15.4W



Spot 15° - Ultra Flood 50°
Trim



14-14 60-60 14-60

7.8 - 15.4W



Spot 15° - Ultra Flood 50°
Trim

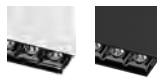

14-60 60-60

7.8 - 15.4W



Spot 15° - Ultra Flood 50°
Trim / Trimless



14-60

Spotlights / Ceilings
Bento IP66 Surface

Downlights
Bento Wallwasher

Low Voltage
Bento Low Voltage

Low Voltage
**Bento Low Voltage
Wallwasher**

Low Voltage
**Bento Low Voltage
Adjustable**

309

243

126

126

126

75 mm



189 mm



143 mm



99 mm



142 mm



125 mm



278 mm



194 mm



274 mm



14.7W



Spot 15° - Flood 47°

○ ● ○ ● ○ ● ○ ●
14 60 34 DL E3 J6 Z5

7.8 - 15.4W



Wall Washer

○ ●
14 60

6 - 12W



Spot 15° - Ultra Flood 50°

○ ●
14 60

7.8 - 15.4W



Wall Washer

○ ●
14 60

6.3 - 13.4W



Spot 15° - Flood 47°

○ ●
14 60





Bento Standard in Taulat Offices project. Architecture: aaa Barcelona by Ignacio Infiesta. Photography: Javier Márquez.

Bento Standard dans le cadre du projet des bureaux Taulat. Architecture: aaa Barcelona par Ignacio Infiesta. Photographie: Javier Márquez.



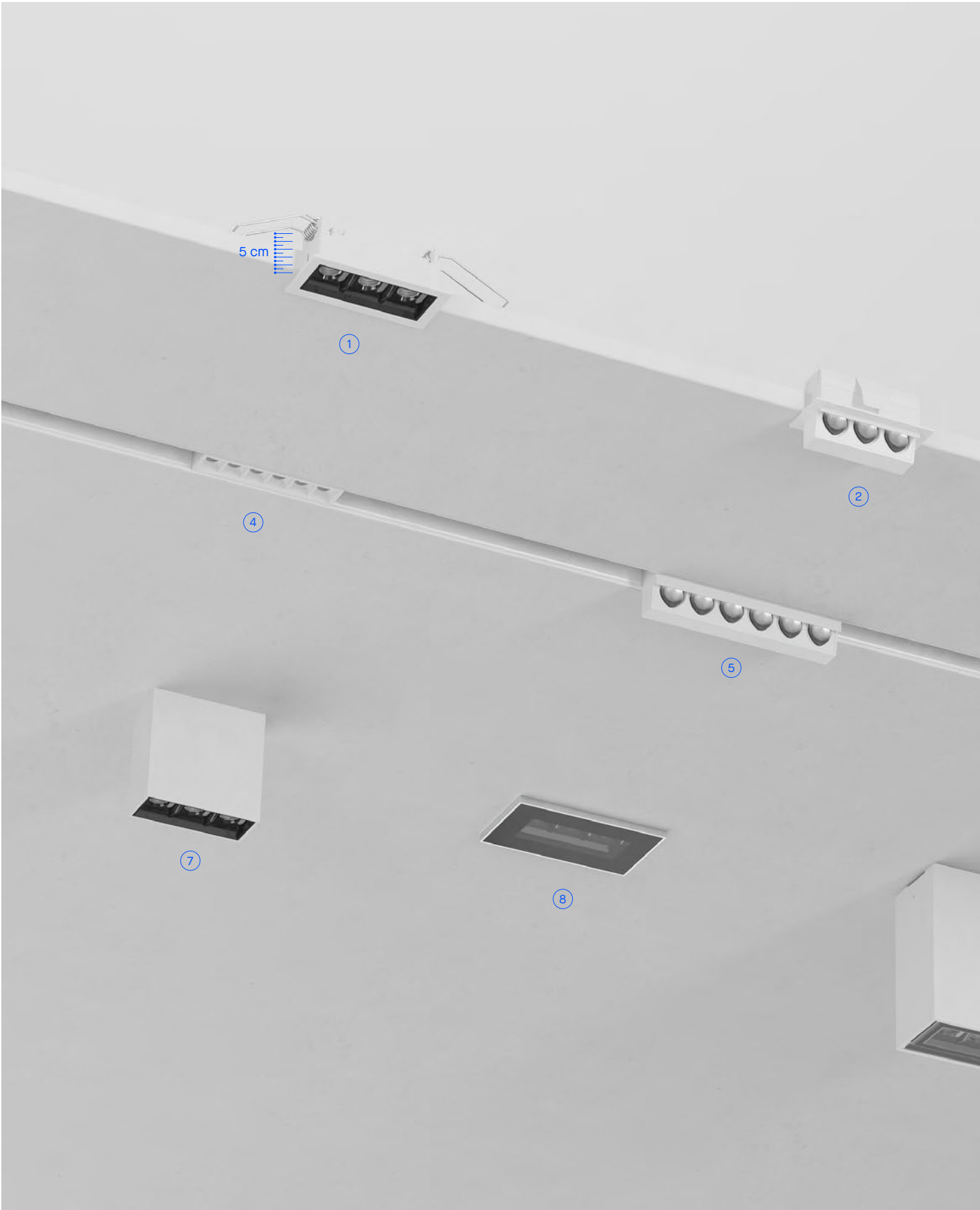

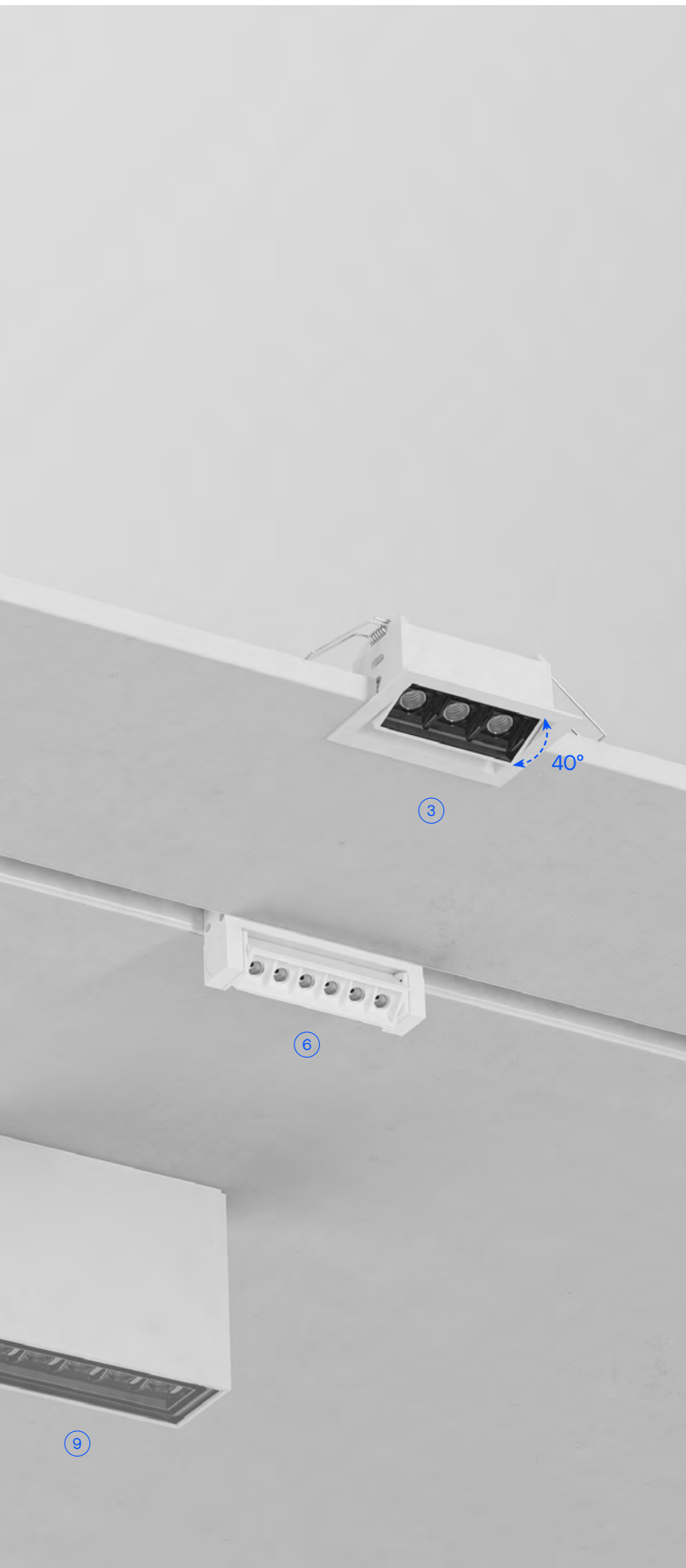

- ① Recessed Trim
- ② Wallwasher Trim
- ③ Adjustable
- ④ Low Voltage
- ⑤ Low Voltage Wallwasher
- ⑥ Low Voltage Adjustable
- ⑦ Surface
- ⑧ IP65 Recessed
- ⑨ IP66 Surface



Iberspa project. Lleida. Photography: Jordi Anguera.
Projet Iberspa. Lleida. Photographie: Jordi Anguera

Version used: Bento Standard
Objective of the project: dark light effect in the cabin for a high
visual comfort and minima
Version utilisée: Bento Standard
Objectif du projet : effet dark light la cabine pour une haute
confort visuel et éblouissement minimal.



Version used: Bento Standard and Bento Surface for integration in wooden ceiling.
A Casambi version with dimmer was used to take advantage of natural light via Bluetooth Mesh.
Version utilisée: Bento Standard et Bento Surface à intégrer dans des plafonds en bois.
Une version Casambi à variation via Bluetooth Mesh a été utilisée pour tirer parti de la lumière naturelle.

Bento Wall Washer

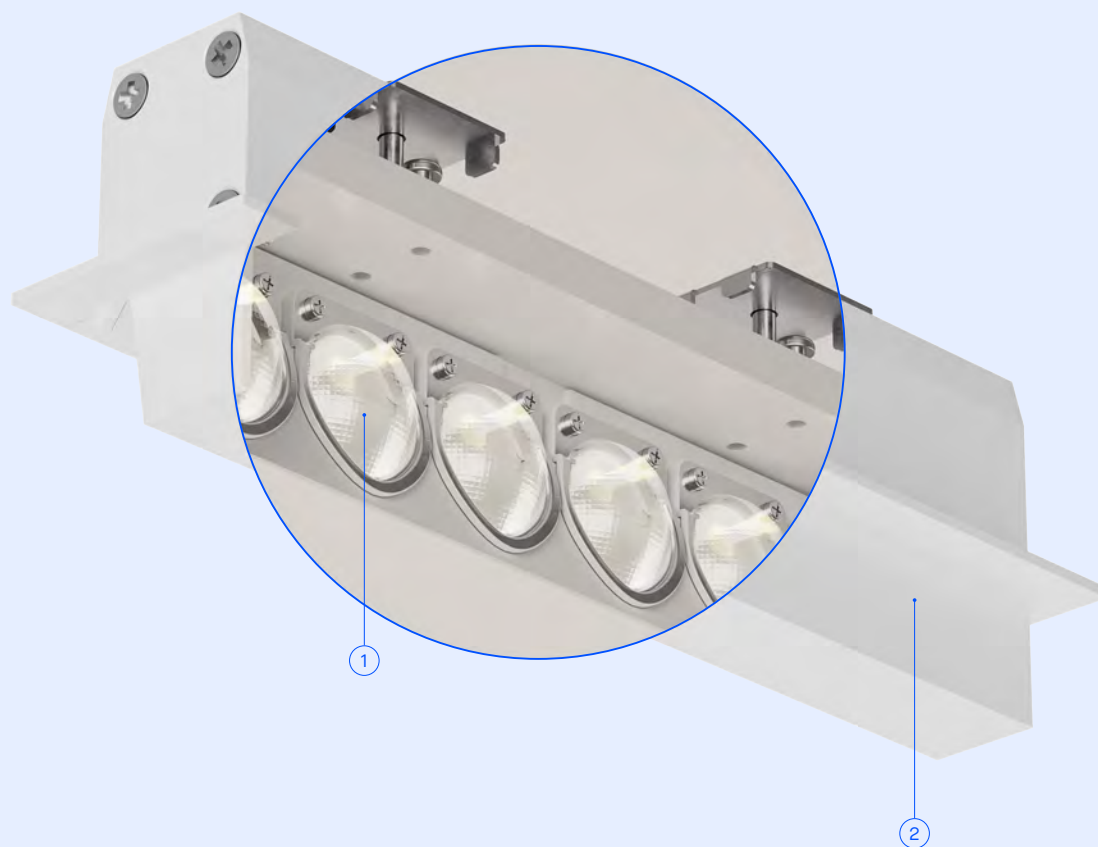

- ① Micro-engraved spoon-shaped reflectors for bathing walls in homogeneous light.
Réflecteurs microgravés en forme de cuillère pour un effet lèche-mur homogène.
- ② Longitudinal shade for Dark Light effect.
Abat-jour longitudinal pour effet Dark Light (lumière sombre).



Kiva

Designed by LedsC4 Architectural



+ Kiva

Spotlights
P. 312



Spotlights
P. 312



Low Voltage
P. 118

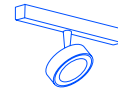

Functionality and aesthetics in the same solution

Fonctionnalité et esthétique dans une même solution

The Kiva collection has been expanded with new features designed to easily provide lighting in any space thanks to its 350° rotation. With recessed, surface-mounted, track or low-voltage versions, the extended collection offers superior versatility and functionality.

La collection Kiva s'étoffe avec de nouvelles fonctionnalités, conçues pour éclairer n'importe quel espace en toute facilité grâce à sa rotation de 350°. Offrant la possibilité de montage encastré, en surface, sur rail ou en versions basse tension, la collection s'enrichit d'une grande polyvalence et fonctionnalité.

Spotlights
Kiva Surface

312

Ø75 mm



Ø95 mm



Spotlights
Kiva Recessed

312

Ø75 mm



Ø95 mm



Low Voltage
Kiva Low Voltage

118

Ø75 mm



Ø95 mm



7.8 - 13.2W



Spot 19° - Medium 23°

○ ● ● ●
14 60 81 DN

8.8 - 14W



Spot 19° - Medium 23°

○ ● ● ●
14 60 81 DN

6.4 - 12W



Spot 19° - Medium 23°

○ ● ● ●
14 60 81 DN

Longitudinal and swivel rotation Rotation longitudinale et pivotante

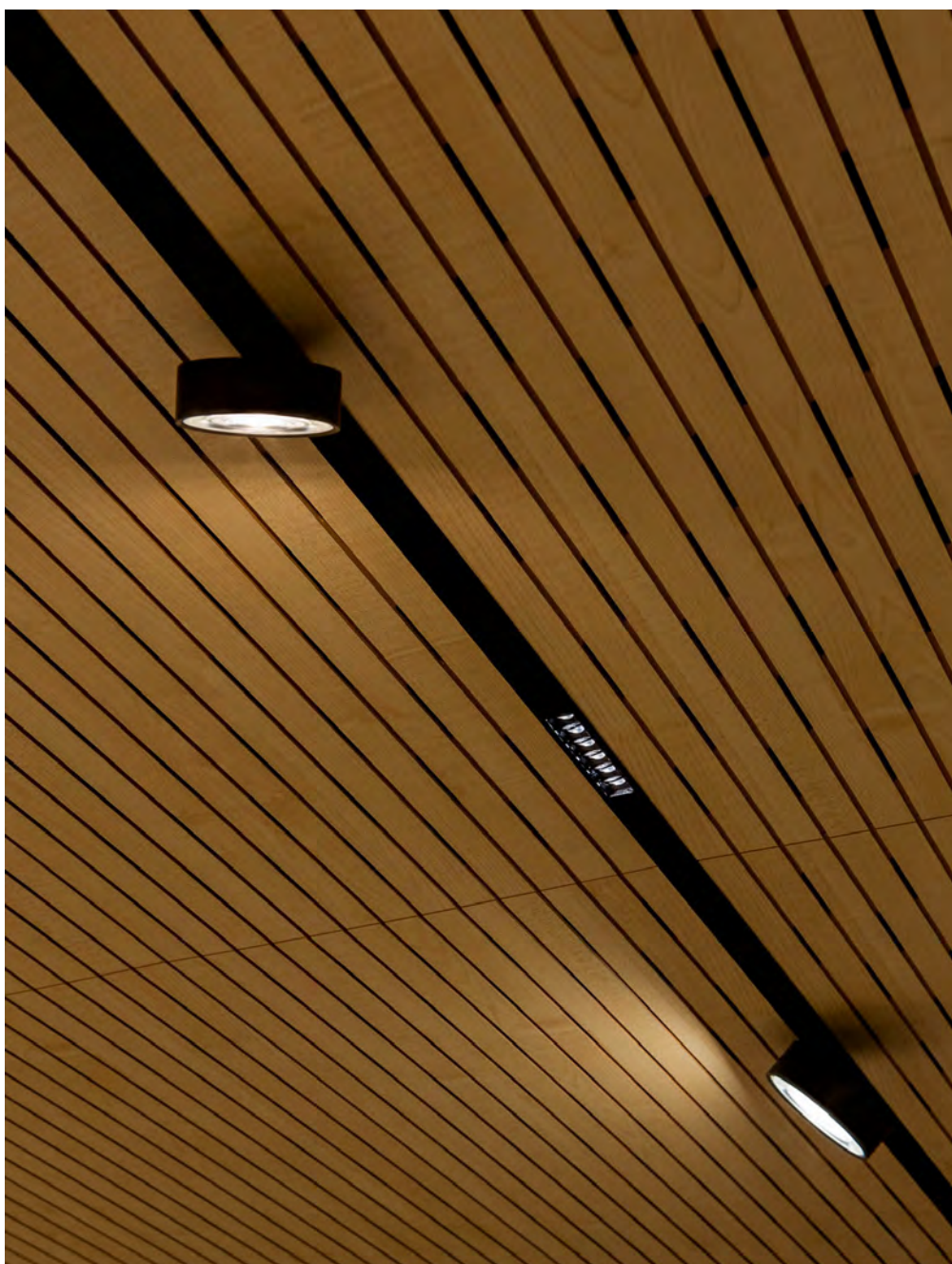



Spotlights / Tracks

Projecteurs / Rails

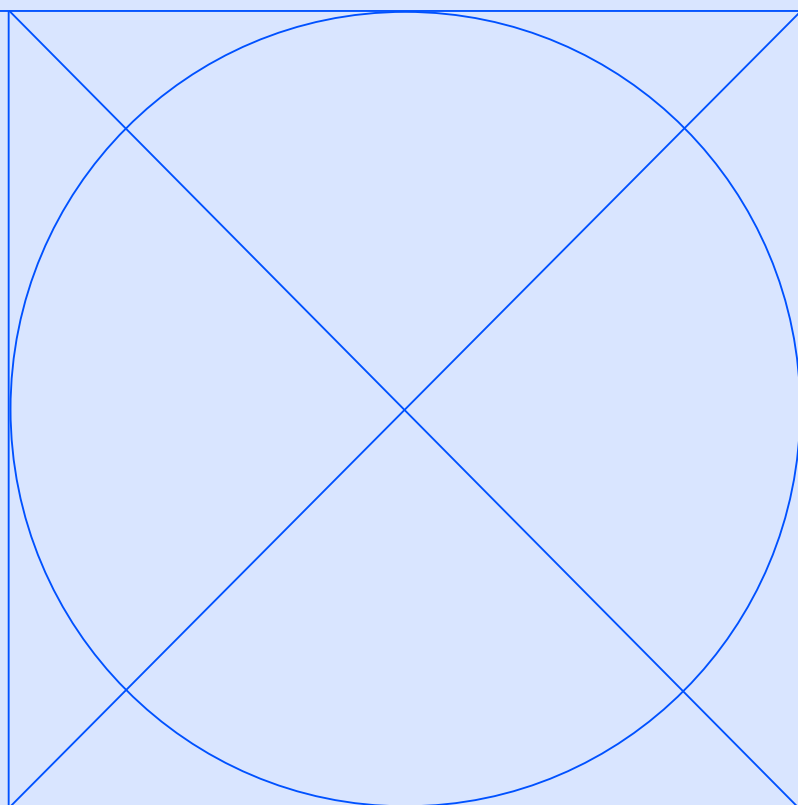

Atom

078

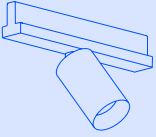

Iris

086

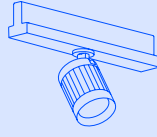

Iris Pendant

086

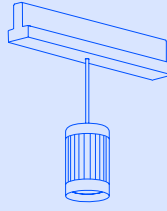

Tak

088

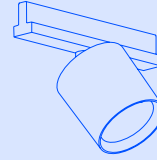

Strom

092

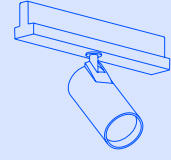

Play

096

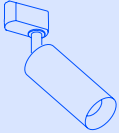

Track Standard

097

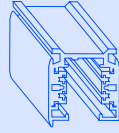

Atom

Designed by LedsC4 Architectural



+ Atom

Low Voltage
P. 114



Recessed
P. 306



Surface
P. 291



Hide
P. 300



A sleek and neutral spotlight on a three-phase track, perfect for various settings. Featuring CRI98 options for outstanding colour rendering and tunable white to tailor the light to the project, the entire collection provides remarkable versatility with various lenses, finishes and accessories for complete customisation to meet specific lighting needs. Projecteur sur rail triphasé au design épuré et neutre, idéal pour toutes sortes d'espace. Avec des options à IRC 98, un excellent rendu des couleurs et un blanc dynamique (tunable white) visant à ajuster l'éclairage au projet, l'ensemble de la collection présente une grande polyvalence, doublée de plusieurs optiques, finitions et accessoires qui permettent de répondre à chaque besoin spécifique.



Atom Track 52 in the restoration project of the Tragaluz group, Fiskebar. Photography: Salva López.
Atom Track 52 dans le projet de restauration du groupe Tragaluz, Fiskebar. Photographie : Salva López.



INDOOR

SPOTLIGHTS / TRACKS | PROJECTEURS / RAILS

CRI98 options guarantee perfect colour rendering

Options à IRC 98 qui garantit un parfait rendu des couleurs



Atom Track 75 in the Casa Tabu project in Milan. Excellent chromatic reproduction to highlight the colours of the product on display. Photography: Germano Borrelli.

Atom Track 75 dans le projet Casa Tabu à Milan. Excellente reproduction chromatique pour mettre en valeur les couleurs du produit exposé. Photographie : Germano Borrelli.

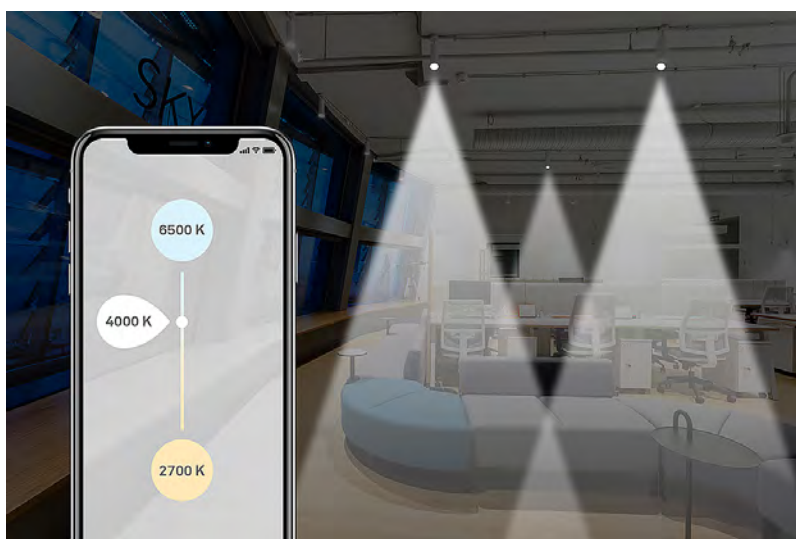

The Tunable White versions allow you to adjust the colour temperature

Versions Tunable White qui permettent de régler la température de couleur

Atom Track 52 LED AC 120V*

BODY MAT	3	IP	50000h	WELL	90°	320°	LED	DRIVER	120V
AL	MacAdam	20	L80 B20						

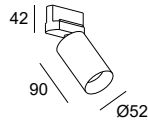
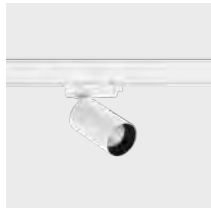

LED							
K	CRI	W Total	Real Lm	Optics	Code		
3000	90	7.5	245	24°	35-6276	14	
3000	90	7.5	308	32°	35-6277	60 - ML PHASE CUT 120V	
3000	90	7.5	325	42°	35-6278		

○ ●
14 60

Atom Track 75 LED AC 120V*

BODY MAT	3	IP	50000h	WELL	90°	320°	LED	DRIVER	120V
AL	MacAdam	20	L80 B20						

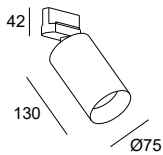

LED							
K	CRI	W Total	Real Lm	Optics	Code		
3000	90	14.3	692	22°	35-6282	14	
3000	90	14.3	870	31°	35-6283	60 - ML PHASE CUT 120V	
3000	90	14.3	916	38°	35-6284		

○ ●
14 60

Atom Track 97 LED AC 120V*

BODY MAT	3	IP	50000h	WELL	90°	320°	LED	DRIVER	120V
AL	MacAdam	20	L80 B20						

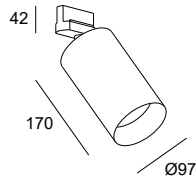

LED							
K	CRI	W Total	Real Lm	Optics	Code		
3000	90	31	1269	24°	35-6288	14	
3000	90	31	1595	36°	35-6289	60 - ML PHASE CUT 120V	
3000	90	31	1679	43°	35-6290		

○ ●
14 60

* Not suitable for the European market
* Ne convient pas au marché européen

Atom Track 52 LED Driver

BODY MAT	3	IP		50000h				
AL	MacAdam	20		L80 B20	320	90		

○ ●
14 60

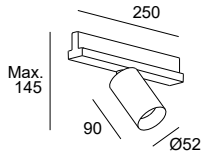

LED									
K	CRI	W Total	Real Lm	Optics	Code				
2700	90	10.5	428	8°	35-A021	14 - OS	ON-OFF	220-240V	
						60 - ES	DALI-2	220-240V	
						60 - XB	CASAMBI	220-240V	⚡
2700	90	14.3	1154	22°	35-7287	14 - OS	ON-OFF	220-240V	
						60 - ES	DALI-2	220-240V	
						60 - XB	CASAMBI	220-240V	⚡
2700	90	14.3	1290	35°	35-7288	14 - OS	ON-OFF	220-240V	
						60 - ES	DALI-2	220-240V	
						60 - XB	CASAMBI	220-240V	⚡
2700	90	14.3	1265	43°	35-7289	14 - OS	ON-OFF	220-240V	
						60 - ES	DALI-2	220-240V	
						60 - XB	CASAMBI	220-240V	⚡
2700	90	21.3	1549	22°	35-A187	14 - OS	ON-OFF	220-240V	
						60 - ES	DALI-2	220-240V	
						60 - XB	CASAMBI	220-240V	⚡
2700	90	21.3	1768	35°	35-A188	14 - OS	ON-OFF	220-240V	
						60 - ES	DALI-2	220-240V	
						60 - XB	CASAMBI	220-240V	⚡
2700	90	21.3	1715	43°	35-A189	14 - OS	ON-OFF	220-240V	
						60 - ES	DALI-2	220-240V	
						60 - XB	CASAMBI	220-240V	⚡
3000	90	10.5	437	8°	35-A022	14 - OS	ON-OFF	220-240V	
						60 - ES	DALI-2	220-240V	
						60 - XB	CASAMBI	220-240V	⚡
3000	90	14.3	1200	22°	35-7290	14 - OS	ON-OFF	220-240V	
						60 - ES	DALI-2	220-240V	
						60 - XB	CASAMBI	220-240V	⚡
3000	90	14.3	1342	35°	35-7291	14 - OS	ON-OFF	220-240V	
						60 - ES	DALI-2	220-240V	
						60 - XB	CASAMBI	220-240V	⚡
3000	90	14.3	1316	43°	35-7292	14 - OS	ON-OFF	220-240V	
						60 - ES	DALI-2	220-240V	
						60 - XB	CASAMBI	220-240V	⚡
3000	90	21.3	1610	22°	35-A190	14 - OS	ON-OFF	220-240V	
						60 - ES	DALI-2	220-240V	
						60 - XB	CASAMBI	220-240V	⚡
3000	90	21.3	1838	35°	35-A191	14 - OS	ON-OFF	220-240V	
						60 - ES	DALI-2	220-240V	
						60 - XB	CASAMBI	220-240V	⚡
3000	90	21.3	1783	43°	35-A192	14 - OS	ON-OFF	220-240V	
						60 - ES	DALI-2	220-240V	
						60 - XB	CASAMBI	220-240V	⚡
4000	90	10.5	459	8°	35-A023	14 - OS	ON-OFF	220-240V	
						60 - ES	DALI-2	220-240V	
						60 - XB	CASAMBI	220-240V	⚡
4000	90	14.3	1333	22°	35-A003	14 - OS	ON-OFF	220-240V	
						60 - ES	DALI-2	220-240V	
						60 - XB	CASAMBI	220-240V	⚡
4000	90	14.3	1492	35°	35-A004	14 - OS	ON-OFF	220-240V	
						60 - ES	DALI-2	220-240V	
						60 - XB	CASAMBI	220-240V	⚡
4000	90	14.3	1462	43°	35-A005	14 - OS	ON-OFF	220-240V	
						60 - ES	DALI-2	220-240V	
						60 - XB	CASAMBI	220-240V	⚡
4000	90	21.3	1790	22°	35-A193	14 - OS	ON-OFF	220-240V	
						60 - ES	DALI-2	220-240V	
						60 - XB	CASAMBI	220-240V	⚡
4000	90	21.3	2043	35°	35-A194	14 - OS	ON-OFF	220-240V	
						60 - ES	DALI-2	220-240V	
						60 - XB	CASAMBI	220-240V	⚡
4000	90	21.3	1981	43°	35-A195	14 - OS	ON-OFF	220-240V	
						60 - ES	DALI-2	220-240V	
						60 - XB	CASAMBI	220-240V	⚡
2700-6500	90	14	926	22°	35-A066	14 - OS	ON-OFF	220-240V	
						60 - ES	DALI-2	220-240V	
						60 - TW	DALI DT8	220-240V	⚡
2700-6500	90	14	1089	38°	35-A067	14 - OS	ON-OFF	220-240V	
						60 - ES	DALI-2	220-240V	
						60 - TW	DALI DT8	220-240V	⚡
2700-6500	90	14	1076	49°	35-A068	14 - OS	ON-OFF	220-240V	
						60 - ES	DALI-2	220-240V	
						60 - TW	DALI DT8	220-240V	⚡

Atom Track 52 LED Driver Zoom

BODY MAT	3	IP		50000h	WELL				
AL	MacAdam	20		L80 B20		320°	90°		

○ ●
14 60

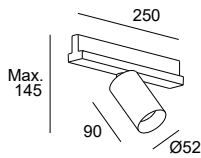

LED									
K	CRI	W Total	Real Lm	Optics	Code				
2700	90	15.3	1113	Zoom 16°-47°	35-A060	14 - OS	ON-OFF	220-240V	
						60 - ES	DALI-2	220-240V	
						60 - XB	CASAMBI	220-240V	⚡
3000	90	15.3	1180	Zoom 16°-47°	35-A061	14 - OS	ON-OFF	220-240V	
						60 - ES	DALI-2	220-240V	
						60 - XB	CASAMBI	220-240V	⚡
4000	90	15.3	1263	Zoom 16°-47°	35-A062	14 - OS	ON-OFF	220-240V	
						60 - ES	DALI-2	220-240V	
						60 - XB	CASAMBI	220-240V	⚡

Atom Track 75 LED Driver

BODY MAT	3	IP		50000h				
AL	MacAdam	20		L80 B20	90	320		

14 60

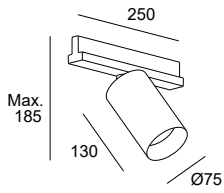

LED									
K	CRI	W Total	Real Lm	Optics	Code				
2700	90	16	1634	16°	35-A018	14	OS	ON-OFF 220-240V	
						60	ES	DALI-2 220-240V	
2700	90	27.5	2336	24°	35-7305	14	OS	ON-OFF 220-240V	
						60	ES	DALI-2 220-240V	
2700	90	27.5	2242	31°	35-7306	14	ES	DALI-2 220-240V	
						60			
2700	90	27.5	2246	37°	35-7307	14	XB	CASAMBI 220-240V	
						60			
2700	90	40.5	3253	24°	35-A196	14	OS	ON-OFF 220-240V	
						60	ES	DALI-2 220-240V	
2700	90	40.5	3535	31°	35-A197	14	ES	DALI-2 220-240V	
						60			
2700	90	40.5	3196	37°	35-A198	14	XB	CASAMBI 220-240V	
						60			
3000	90	16	1667	16°	35-A019	14	OS	ON-OFF 220-240V	
						60	ES	DALI-2 220-240V	
3000	90	27.5	2430	24°	35-7308	14	OS	ON-OFF 220-240V	
						60	ES	DALI-2 220-240V	
3000	90	27.5	2331	31°	35-7309	14	ES	DALI-2 220-240V	
						60			
3000	90	27.5	2336	37°	35-7310	14	XB	CASAMBI 220-240V	
						60			
3000	90	40.5	3383	24°	35-A199	14	OS	ON-OFF 220-240V	
						60	ES	DALI-2 220-240V	
3000	90	40.5	3310	31°	35-A200	14	ES	DALI-2 220-240V	
						60			
3000	90	40.5	3323	37°	35-A201	14	XB	CASAMBI 220-240V	
						60			
4000	90	16	1751	16°	35-A020	14	OS	ON-OFF 220-240V	
						60	ES	DALI-2 220-240V	
4000	90	27.5	2699	24°	35-A009	14	OS	ON-OFF 220-240V	
						60	ES	DALI-2 220-240V	
4000	90	27.5	2589	31°	35-A010	14	ES	DALI-2 220-240V	
						60			
4000	90	27.5	2596	37°	35-A011	14	XB	CASAMBI 220-240V	
						60			
4000	90	40.5	3759	24°	35-A202	14	OS	ON-OFF 220-240V	
						60	ES	DALI-2 220-240V	
4000	90	40.5	3677	31°	35-A203	14	ES	DALI-2 220-240V	
						60			
4000	90	40.5	3693	37°	35-A204	14	XB	CASAMBI 220-240V	
						60			
2700-6500	92	23.8	2214	21°	35-A051	14			
						60	TW	DALI DT8 220-240V	
2700-6500	92	23.8	2090	34°	35-A052	14			
						60			
2700-6500	92	23.8	2078	46°	35-A053	14			

Atom Track 97 LED Driver

DIF MAT	IP					
PMMA	20		90	320		

○ ●
14 60

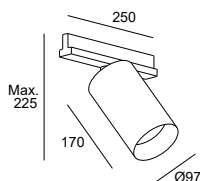

LED									
K	CRI	W Total	Real Lm	Optics	Code				
2700	90	40.5	3905	20°	35-7323	- 14 - 60	OS	ON-OFF	220-240V
2700	90	40.5	3958	26°	35-7324		ES	DALI-2	220-240V
2700	90	40.5	3956	44°	35-7325		XB	CASAMBI	220-240V
2700	90	46.8	4882	20°	35-A205	- 14 - 60	OS	ON-OFF	220-240V
2700	90	46.8	5022	26°	35-A206		OS	ON-OFF	220-240V
2700	90	46.8	5005	44°	35-A207				
3000	90	40.5	4061	20°	35-7326	- 14 - 60	OS	ON-OFF	220-240V
3000	90	40.5	4116	26°	35-7327		ES	DALI-2	220-240V
3000	90	40.5	4114	44°	35-7328		XB	CASAMBI	220-240V
3000	90	46.8	5226	20°	35-A208	- 14 - 60	OS	ON-OFF	220-240V
3000	90	46.8	5311	26°	35-A209		OS	ON-OFF	220-240V
3000	90	46.8	5487	44°	35-A210				
4000	90	40.5	4512	20°	35-A015	- 14 - 60	OS	ON-OFF	220-240V
4000	90	40.5	4574	26°	35-A016		ES	DALI-2	220-240V
4000	90	40.5	4572	44°	35-A017		XB	CASAMBI	220-240V
4000	90	46.8	5641	20°	35-A211	- 14 - 60	OS	ON-OFF	220-240V
4000	90	46.8	5784	26°	35-A212		OS	ON-OFF	220-240V
4000	90	46.8	5804	44°	35-A213				
2700-6500	92	37	3118	20°	35-A077	- 14 - 60			
2700-6500	92	37	2892	26°	35-A078		TW	DALI DT8	220-240V
2700-6500	92	37	2212	44°	35-A079				

Atom Track 52 LED Driver (DALI-2)



Atom Track 52 LED Driver Zoom (DALI-2)



Atom Track 75 LED Driver (DALI-2)



Atom Track 97 LED Driver (DALI-2)



Controllers / Contrôleurs

P. 984



Track DALI-2 Broadcast dimmer / Variateur DALI-2 Broadcast sur rail

14 ○	35-A075-14-00	35-A075-14-00	35-A075-14-00	35-A075-14-00
60 ●	35-A075-60-00	35-A075-60-00	35-A075-60-00	35-A075-60-00

Connective controllers / Contrôleurs connectés

P. 969



Consult the available control systems / Consultez les systèmes de contrôle disponibles:
 DALI2 / DALI2
 Bluetooth wireless / Sans fil Bluetooth
 Autonomous / Autonome

Atom Track 52
LED Driver + LED AC

Atom Track 52
LED Driver Zoom







Atom Track 75
LED Driver + LED AC

Atom Track 97
LED Driver + LED AC



INDOOR

Lens accessories
Accessoires optiques

	Elliptical diffuser (5u.) Diffuseur elliptique (5 u.)		71-6274-00-00	-	71-6280-00-00	71-6286-00-00
	Halo fader (5u.) Diffuseur de halo (5 u.)		71-6275-00-00	-	71-6281-00-00	71-6287-00-00
	Visual comfort (1u.) Confort visuel (1 u.)	14 ○	71-6276-14-00	-	71-6282-14-00	71-6288-14-00
		60 ●	71-6276-60-00	-	71-6282-60-00	71-6288-60-00
	Honeycomb panel (5u.) Grille en nid d'abeille (5 u.)		71-6273-60-00	-	71-6279-60-00	71-6285-60-00
	Visor Visière		71-6277-60-00	-	71-6283-60-00	71-6289-60-00
	Anti-glare flaps Ailettes anti-éblouissement	14 ○	-	-	-	71-6290-14-00
		60 ●	-	-	-	71-6290-60-00
	Front ring Anneau frontal	14 ○	71-6436-14-00	-	71-6437-14-00	71-6438-14-00
		23 ●	71-6436-23-00	-	71-6437-23-00	71-6438-23-00

SPOTLIGHTS / TRACKS | PROJECTEURS / RAILS

Iris

Designed by Artec Studio



+ Iris

Low Voltage
P. 120



Pendant
P. 268



Ceiling
P. 274



Spotlight Surf.
P. 274



Power and control of the beam Contrôle de la puissance et du faisceau

Projector for three-phase track with versatile finishes and a combination of components. With optimum light efficiency, Iris' wide range of lenses make it possible to accentuate illuminated objects with superior power and beam control.

Projecteur pour rail triphasé offrant un vaste éventail de finitions et de composants. Grâce à une efficacité d'éclairage optimale et à la diversité des optiques, Iris permet d'accentuer les objets éclairés de façon puissante et en contrôlant le faisceau.

Iris Track Spotlight



Iris Track Pendant

BODY MAT		50000h	2	IP		
AL		L80 B20	MacAdam	23		

Code example / Exemple d'élaboration d'une référence: **AV25-P6V9U10S60**

Model		W	K	CRI	Shades	Real Lm	Optics	Source	Finishes
 Max. 143 Ø55 AV21 - Spotlight Track 3-Phase	P6V9	6.3	2700	90	U Hoop	533-750	1 15°	OS ON-OFF 220-240V	60
	P6W9	6.3	3000	90	V Visual	249-357	2 35°	DS DALI-2 220-240V	
	P6X9	6.3	4000	90	X Cone	527-707	3 50°		
	Y Glass					382-461			
	Z Pipe					376-466			
 Max. 2000 Ø55 AV25 - Pendant Track 3-Phase	12V9	12.5	2700	90	U Hoop	1183-1573	1 15°	OS ON-OFF 220-240V	60
	12W9	12.5	3000	90	V Visual	518-689	2 35°	DS DALI-2 220-240V	
	12X9	12.5	4000	90	X Cone	1211-1477	3 50°		
	Y Glass					782-1023			
	Z Pipe					869-1023			
	18V9	18.1	2700	90	U Hoop	1592-2142	1 15°	OS ON-OFF 220-240V	60
	18W9	18.1	3000	90	V Visual	711-939	2 35°	DS DALI-2 220-240V	
	18X9	18.1	4000	90	X Cone	1653-2037	3 50°		
	Y Glass					1071-1360			
Z Pipe					1161-1422				



Finishes / Finitions

Selection of finishes available on the online configurator
 Sélection de finitions disponibles grâce au configurateur en ligne



Configurator
Configurateur
iris.ledsc4.com



Lens accessories Accessoires optiques

	Elliptical diffuser (5u.) Diffuseur elliptique (5 u.)	71-5167-00-00		Honeycomb panel (5u.) Grille en nid d'abeille (5 u.)	71-5166-60-00
	Square diffuser (5u.) Diffuseur carré (5 u.)	71-5658-00-00		Screen (5u.) Diffuseur (5 u.)	71-7895-60-00
	Halo fader (5u.) Diffuseur de halo (5 u.)	71-6099-00-00			

Tak

Essential
SOLUTION

Designed by LedsC4 Architectural



Practicality, functionality and efficiency define this basic spotlight, ideal for retail settings requiring high visual comfort and perfect colour rendering in a compact solution. The driver is included in the luminaire and integrated within the track.

Commodité, fonctionnalité et efficacité définissent ce projecteur de base, idéal pour les applications de commerce de détail qui exigent un haut confort visuel doublé d'un parfait rendu des couleurs en une solution compacte. Le driver est fourni avec le luminaire et intégré dans le rail.

High visual comfort
Grand confort visuel

Compact size
Dimension compacte

Excellent heat dissipation
Excellente dissipation
technique





0
Goods
Women / Mujer
Kids / Niños

-1
/ Men / Hombre
CAMPER LAB









Tak in the Casa Camper Valencia project. Photography: Biel Aliño. Architecture and interior design by Marta Armengol.

Tak dans le cadre du projet Casa Camper de Valence, en Espagne. Photographie : Biel Aliño. Architecture et décoration d'intérieur : Marta Armengol.

Tak

BODY MAT	DIF MAT		50000h	2	IP					
AL	PC		L80 B20	MacAdam	20					

14 60

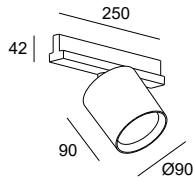

LED										
K	CRI	W Total	Real Lm	Optics	Code					
3000	90	30.5	3153	16°	35-A054					
3000	90	40.2	3963	16°	35-A181					
3000	90	30.5	3063	26°	35-A055	14	OS	ON-OFF 220-240V		
3000	90	40.2	3859	26°	35-A182	60	DS	DALI-2 220-240V		
3000	90	30.5	3022	55°	35-A056					
3000	90	40.2	3792	55°	35-A183					
4000	90	30.5	3201	16°	35-A057					
4000	90	40.2	4028	16°	35-A184					
4000	90	30.5	3109	26°	35-A058	14	OS	ON-OFF 220-240V		
4000	90	40.2	3917	26°	35-A185	60	DS	DALI-2 220-240V		
4000	90	30.5	3068	55°	35-A059					
4000	90	40.2	3849	55°	35-A186					

Lens accessories Accessoires optiques



Honeycomb panel (5u.)
Grille en nid d'abeille (5 u.)

71-A177-60-00

Connective controllers Contrôleurs connectés

P. 969



Consult the available control systems / Consultez les systèmes de contrôle disponibles:
DALI2 / DALI2
Bluetooth wireless / Sans fil Bluetooth
Autonomous / Autonome

Strom



The Strom spotlight is specially designed for accent lighting in retail and museum environments. Thanks to the careful selection of the light source and its high colour rendering, Strom brings out the colours in the products on display.

Le projecteur Strom est spécialement conçu pour l'éclairage d'accentuation dans les magasins et les musées. Grâce à la sélection minutieuse de la source lumineuse et à son haut rendu des couleurs, Strom fait ressortir les couleurs des produits exposés.

Excellent uniformity
Excellente uniformité

Manual zoom
Zoom manuel

Option to manually adjust the light beam.
Possibilité d'ajuster le faisceau lumineux manuellement.



106 lm/w of efficiency
Efficacité de 106 lm/w



Strom Ø55

BODY MAT	DIF MAT		50000h	2	IP					
AL	PC		L80 B20	MacAdam	20	90°	355°			

○ ●
H2 G7

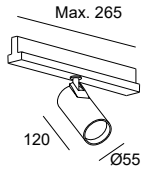

LED										
K	CRI	W Total	Real Lm	Optics	Code					
3000	92	23.6	2272	15°	35-A090	H2 G7	OS	ON-OFF	220-240VAC	
3000	92	23.6	2250	24°	35-A091		- DS	DALI-2	220-240VAC	
3000	92	23.6	2227	38°	35-A092		XB	CASAMBI	220-240VAC	⚡
3500	92	23.6	2297	15°	35-A093	H2 G7	OS	ON-OFF	220-240VAC	
3500	92	23.6	2275	24°	35-A094		- DS	DALI-2	220-240VAC	
3500	92	23.6	2252	38°	35-A095		XB	CASAMBI	220-240VAC	⚡
4000	92	23.6	2362	15°	35-A096	H2 G7	OS	ON-OFF	220-240VAC	
4000	92	23.6	2339	24°	35-A097		- DS	DALI-2	220-240VAC	
4000	92	23.6	2315	38°	35-A098		XB	CASAMBI	220-240VAC	⚡

Strom Ø55 Zoom

	BODY MAT	DIF MAT		50000h	2	IP				
AL	PC		L80 B20	MacAdam	20	90°	320°			

○ ●
H2 G7

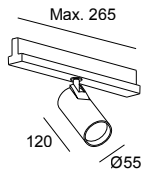

LED										
K	CRI	W Total	Real Lm	Optics	Code					
3000	92	12.5	1044	Zoom 15°-45°	35-A175	H2 G7	OS	ON-OFF	220-240V	
							XB	CASAMBI	220-240V	⚡
3500	92	12.5	1096	Zoom 15°-45°	35-A176	H2 G7	OS	ON-OFF	220-240V	
							XB	CASAMBI	220-240V	⚡
4000	92	12.5	1111	Zoom 15°-45°	35-A177	H2 G7	OS	ON-OFF	220-240V	
							XB	CASAMBI	220-240V	⚡

Strom Low Voltage Ø55

IP	BODY MAT	DIF MAT		50000h	2	LOW				
20	AL	PC		L80 B20	MacAdam	FLICKER	320°	90°		

○ ●
H2 G7

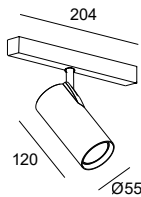

LED										
K	CRI	W Total	Real Lm	Optics	Code					
3000	92	24	2272	15°	35-A166	H2 G7	OS	ON-OFF	48 VDC	
3000	92	24	2250	24°	35-A167		- DS	DALI	48 VDC	
3000	92	24	2227	38°	35-A168		XB	CASAMBI	48 VDC	⚡
3500	92	24	2297	15°	35-A169	H2 G7	OS	ON-OFF	48 VDC	
3500	92	24	2275	24°	35-A170		- DS	DALI	48 VDC	
3500	92	24	2252	38°	35-A171		XB	CASAMBI	48 VDC	⚡
4000	92	24	2362	15°	35-A172	H2 G7	OS	ON-OFF	48 VDC	
4000	92	24	2339	24°	35-A173		- DS	DALI	48 VDC	
4000	92	24	2315	38°	35-A174		XB	CASAMBI	48 VDC	⚡

Strom Ø80

BODY MAT	DIF MAT	IP	50000h	2	90°	320°	LED	DRIVER
AL	PC	0	L80 B20	MacAdam				

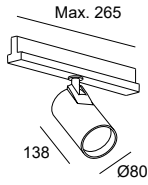

○ ●
H2 G7

LED									
K	CRI	W Total	Real Lm	Optics	Code				
3000	92	34	3294	15°	35-A118	H2	OS	ON-OFF	220-240V
3000	92	34	3266	24°	35-A123	G7	- DS	DALI-2	220-240V
3000	92	34	3219	38°	35-A126		XB	CASAMBI	220-240V
3500	92	34	3627	15°	35-A120	H2	OS	ON-OFF	220-240V
3500	92	34	3534	24°	35-A124	G7	- DS	DALI-2	220-240V
3500	92	34	3542	38°	35-A127		XB	CASAMBI	220-240V
4000	92	34	3607	15°	35-A122	H2	OS	ON-OFF	220-240V
4000	92	34	3500	24°	35-A125	G7	- DS	DALI-2	220-240V
4000	92	34	3543	38°	35-A128		XB	CASAMBI	220-240V

Strom Ø80 Zoom

NEW	BODY MAT	DIF MAT	50000h	2	IP	90°	355°	LED	DRIVER
	AL	PC	L80 B20	MacAdam	20				

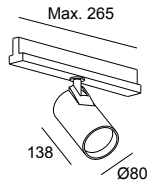

○ ●
H2 G7

LED									
K	CRI	W Total	Real Lm	Optics	Code				
3000	92	24	2267	Zoom 15°-45°	35-A178	H2	OS	ON-OFF	220-240V
						G7	- RU	0-10V	220-240V
							XB	CASAMBI	220-240V
3500	92	24	2349	Zoom 15°-45°	35-A179	H2	OS	ON-OFF	220-240V
						G7	- RU	0-10V	220-240V
							XB	CASAMBI	220-240V
4000	92	24	2412	Zoom 15°-45°	35-A180	H2	OS	ON-OFF	220-240V
						G7	- RU	0-10V	220-240V
							XB	CASAMBI	220-240V

**Strom Ø80
Bread / Fish / Meat**

BODY MAT	DIF MAT	IP	50000h	320°	90°	LED	DRIVER
AL	PC	0	L80 B20				

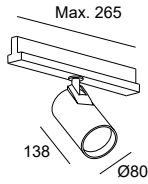

○ ●
H2 G7

LED									
K	W Total	Real Lm	Optics	Code					
Special Meat	34	1513	38°	35-A129	H2	OS	ON-OFF	220-240V	
					G7				
Special Bread	34	2233	38°	35-A131	H2	OS	ON-OFF	220-240V	
					G7				
Special Fish	34	2371	38°	35-A130	H2	OS	ON-OFF	220-240V	
					G7				

Play Deco Track

Downlight
P. 184

Pendant
P. 271



+ Play

Play Deco Track

BODY MAT	DIF MAT		2	LED	DRIVER
AL	PMMA		MacAdam		

Code example / Exemple d'élaboration d'une référence: **AG71-P7V9S20UWG**

Model		W	K	CRI	Lm	Optics	Source	Finishes
<p>AG71 - Spotlight Track</p>	P7V9	8.6	2700	90	521-554	S2 15°	OU ON-OFF 100-240V	WG
	P7W9	8.6	3000	90	604-642	M2 28°	TS PHASE CUT 220-240V	WH
	P7X9	8.6	4000	90	604-646	F1 49°	DU DALI-2 110-277V	WL
	13V9	14.4	2700	80	1070-1167	S2 20°	OU ON-OFF 100-240V	WM
	13W9	14.4	3000	80	1152-1276	M2 33°	TS PHASE CUT 220-240V	WN
	13X9	14.4	4000	80	1233-1344	F1 44°	DU DALI-2 110-277V	WR

Connective controllers Contrôleurs connectés

P. 969



Consult the available control systems / Consultez les systèmes de contrôle disponibles:

DALI2 / DALI2

Bluetooth wireless / Sans fil Bluetooth

Autonomous / Autonome

Track



+ Track



Track is LedsC4's collection of tracks. In its Standard and Euro Dali versions it has several options available, all of which provide great versatility and composition choices.

Track est la collection de rails de LedsC4. Dans ses variantes Standard et Euro Dali, ils sont proposés avec différentes options, qui offrent toutes une grande polyvalence et des possibilités de composition.



Special project **Atom Track**. Vic Light Laboratory. Photo: Leafhopper.
Projet spécial **Atom Track**. Vic Light Laboratory. Photo : Leafhopper.



Casa Tabu Showroom Project. **Atom Track**. Photos: Germano Borrelli.
Projet de salle d'exposition Casa Tabu. **Atom Track**. Photos : Germano Borrelli.



Thinking Mu Flagship Pop-Up Project. Barcelona. **Recessed Track** with Strom spotlight. Interior design: Isern Serra. Photography: Salva López.
Projet Pop Up Flagship Thinking Mu. Barcelone. **Rail Track encastré** avec projecteur Strom. Architecture d'intérieur : Isern Serra. Photographie : Salva López.

Installation diagram Track Standard Surface

Schéma d'installation Track Standard Surface



① Main connector



② Straight track connector



③ Flexible Joint

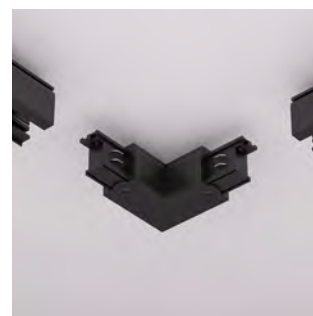

④ L Joint

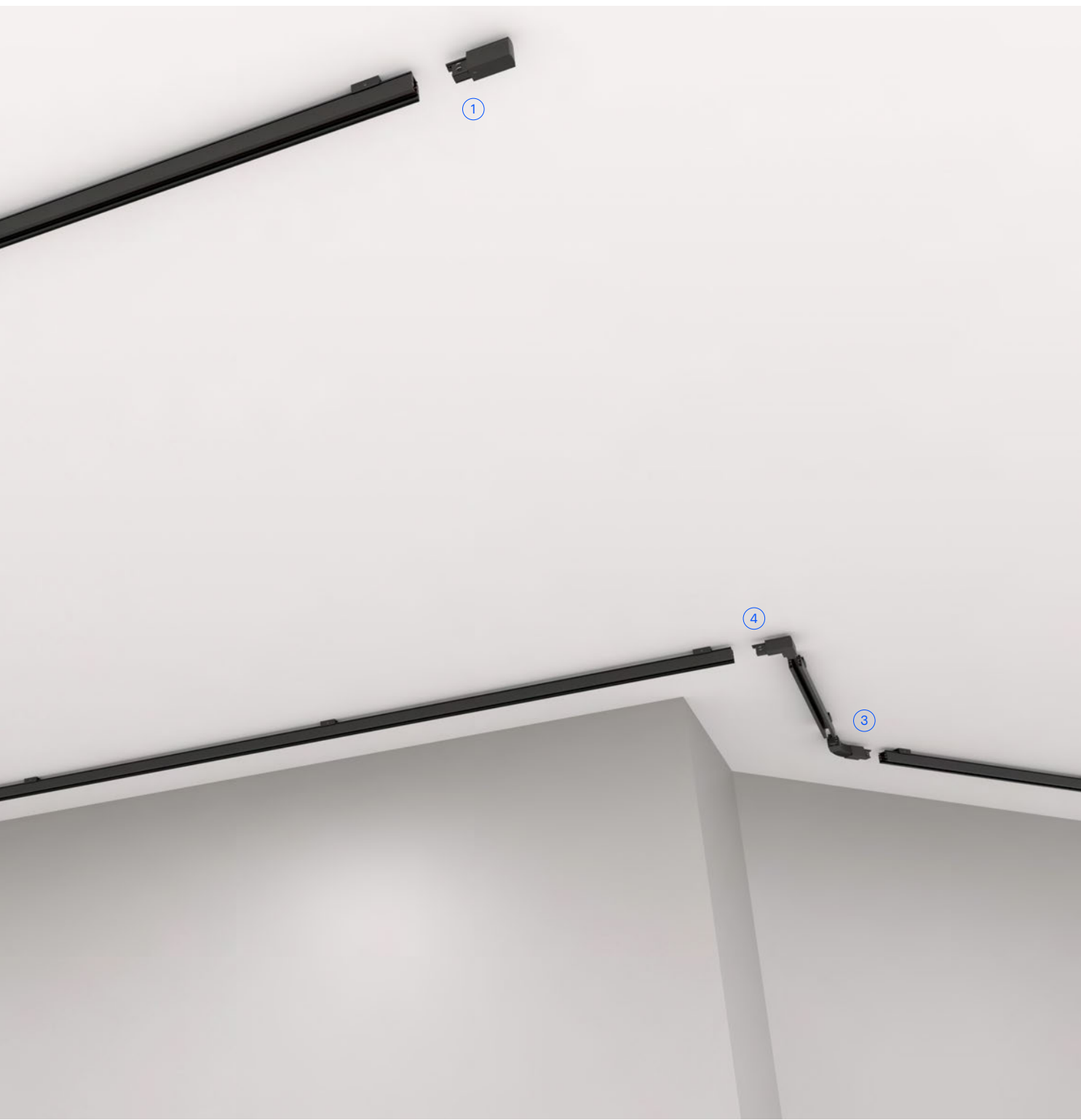

⑤ X Joint

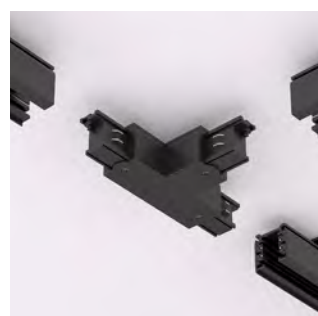

⑥ T Joint

Surface



Pendant



Recessed



Track is available in a Trim and Trimless version, with the choice of surface, pendant or recessed, and white or black finishes.

Track est disponible en version Trim et Trimless avec option surface, suspension ou encastrée et finitions noir et blanc.

**Installation diagram
Schéma d'installation**

The composition possibilities (with or without trim) follow a composition outline devised by references with different proposed connectors.

Les possibilités de composition avec ou sans cadre suivent un schéma de composition par références, avec différents connecteurs proposés.

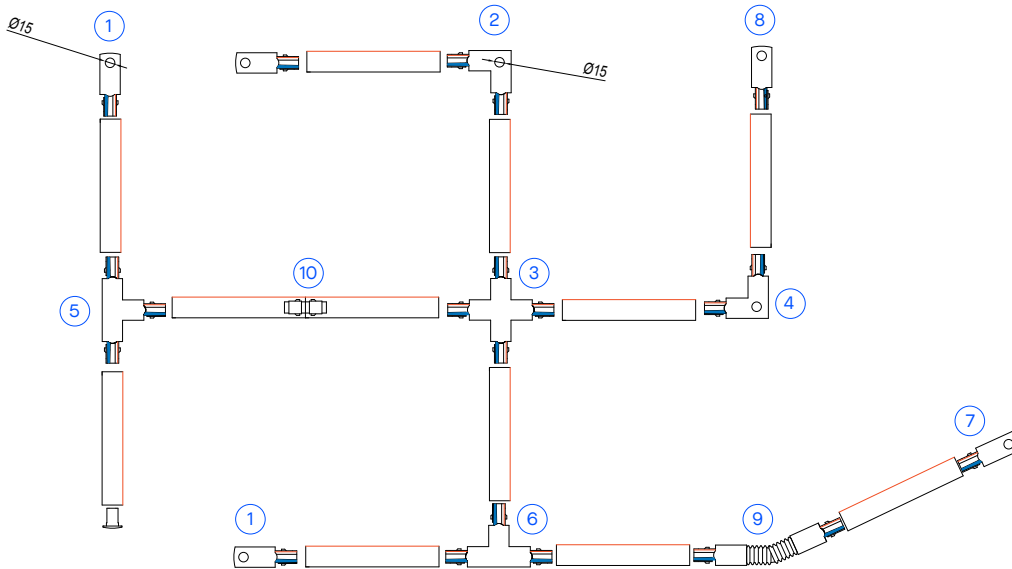

**SURFACE & PENDANT
TRIMLESS**

- ① 71-5214
- ② 71-5219
- ③ 71-5231
- ④ 71-5220
- ⑤ 71-5227
- ⑥ 71-5228
- ⑦ 71-5215

RECESSED TRIM

- ① 71-5216
- ② 71-5221
- ③ 71-5232
- ④ 71-5222
- ⑤ 71-5229
- ⑥ 71-5230
- ⑦ 71-5217

SURFACE, PENDANT & RECESSED

- ① 71-5218
- ⑨ 71-5223
- ⑩ 71-5224

Surface & Pendant Trimless

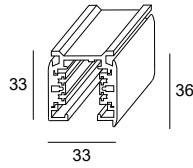

mm	Code
2000	71-5210 - 14 - 00
3000	71-5211 - 60 - 00

○ ●
14 60

INDOOR

Recessed Trim

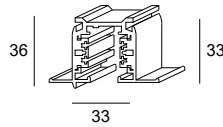

mm	Code
2000	71-5213 - 14 - 00
	60 - 00

○ ●
14 60

Surfaced & Pendant Trimless



Recessed Trim



Required fixing accessories

Accessoires de fixation nécessaires

	Suspended ceiling rose with electrical outlet ON-OFF (2500mm) Patère suspendue avec prise de courant ON-OFF (2500mm)	14 ○	71-7520-14-00	-
		60 ●	71-7520-60-00	-
	2000mm Steel cable + suspended assembly clip (2u.) Câble en acier 2000mm + clip de fixation suspendue (2 u.)	14 ○	71-7656-14-00	-
		60 ●	71-7656-60-00	-
	Clip for direct ceiling attachment (4u.) Clip de fixation directe au plafond (4 u.)	14 ○	71-5225-14-00	-
		60 ●	71-5225-60-00	-
	Recessing kit (2u.) Kit d'encastrement (2 u.)		-	ACT-9165-48-00
	Fixed bars 1000mm (2u.) Barres fixes 1000mm (2u.)	14 ○	71-B503-14-00	-
		60 ●	71-B503-60-00	-
	Fixed bar (1000 mm) extension kit (2u.) Kit de rallonge à barre fixe 1 000 mm (2u.)	14 ○	71-B504-14-00	-
		60 ●	71-B504-60-00	-

Decorative accessories

Accessoires décoratifs

	End cap (1u.) Cache final (1 u.)	14 ○	71-5218-14-00	71-5218-14-00
		60 ●	71-5218-60-00	71-5218-60-00











Surface & Pendant

Recessed Trim



Connection accessories

Accessoires de connexion

	"I" connector Connecteur en « I »	14 ○	71-B219-14-00	71-B219-14-00
		60 ●	71-B219-60-00	71-B219-60-00
	"L" right connector Connecteur gauche en « L »	14 ○	71-5220-14-00	71-5222-14-00
		60 ●	71-5220-60-00	71-5222-60-00
	"L" left connector Connecteur gauche en « L »	14 ○	71-5219-14-00	71-5221-14-00
		60 ●	71-5219-60-00	71-5221-60-00
	"T" right connector Connecteur droit en « T »	14 ○	71-5228-14-00	71-5230-14-00
		60 ●	71-5228-60-00	71-5230-60-00
	"T" left connector Connecteur gauche en « T »	14 ○	71-5227-14-00	71-5229-14-00
		60 ●	71-5227-60-00	71-5229-60-00
	Right connector Connecteur droit	14 ○	71-5215-14-00	71-5217-14-00
		60 ●	71-5215-60-00	71-5217-60-00
	Left connector Connecteur gauche	14 ○	71-5214-14-00	71-5216-14-00
		60 ●	71-5214-60-00	71-5216-60-00
	"X" connector Connecteur en « X »	14 ○	71-5231-14-00	71-5232-14-00
		60 ●	71-5231-60-00	71-5232-60-00
	Flexible connector Connecteur flexible	14 ○	71-5223-14-00	71-5223-14-00
		60 ●	71-5223-60-00	71-5223-60-00
	Continuity connector Connecteur de continuité	14 ○	71-5224-14-00	71-5224-14-00
		60 ●	71-5224-60-00	71-5224-60-00

Surface



Pendant



In its attached and suspended versions, and in black and white finishes, Track Euro Dali offers different connectivity options.

Disponible en version surface et suspension et finitions blanc et noir, Track Euro Dali est l'option connectée du rail, avec différentes options de connectivité.

Track Euro Dali Surface and Pendant

The trimless composition possibilities follow a composition outline devised by references with different proposed connectors.

Les possibilités de composition sans cadre suivent un schéma de composition par références, avec différents connecteurs proposés.

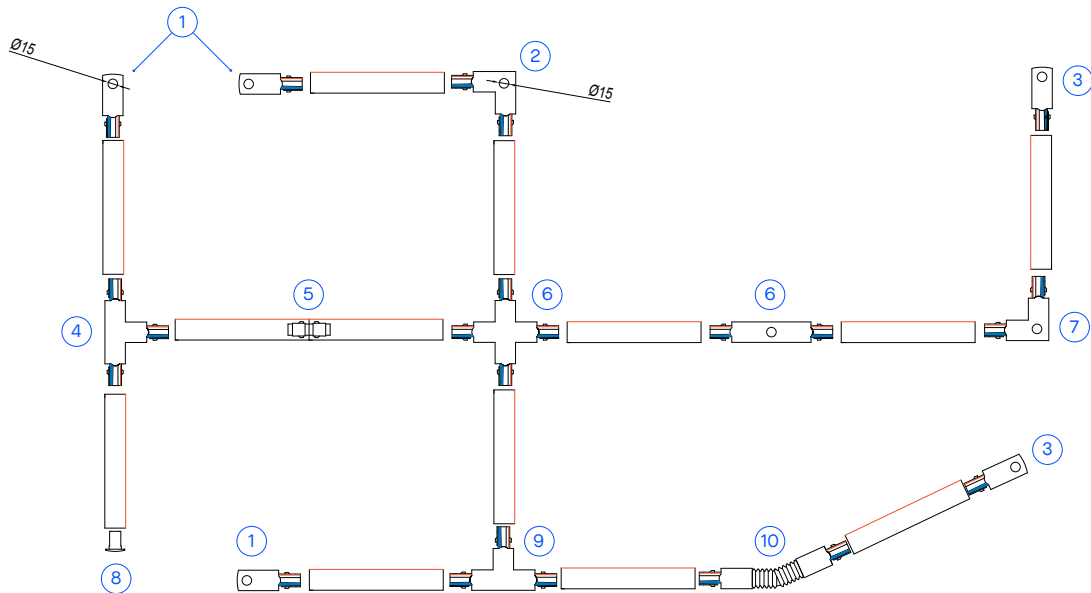

SURFACE & PENDANT TRIMLESS

① 71-7538

④ 71-7544

⑦ 71-7543

⑩ 71-7547

② 71-7542

⑤ 71-7540

⑧ 71-7537

③ 71-7539

⑥ 71-7541

⑨ 71-7545

Tracks Euro Dali Surface & Pendant

○ ●
14 60

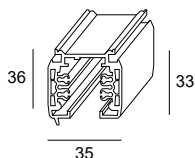

mm
1000
2000
3000

Code

71-7534
71-7535 - 14 - 00
71-7536 - 60 - 00

Required fixing accessories

Accessoires de fixation nécessaires



DALI suspended ceiling rose with electrical outlet (2500mm)
Patère suspendue avec prise de courant DALI (2500mm)

14 ○ **71-7521-14-00**

60 ● **71-7521-60-00**



2000mm Steel cable + suspended assembly clip (2u.)
Câble en acier 2000mm + clip de fixation suspendue (2 u.)

14 ○ **71-7656-14-00**

60 ● **71-7656-60-60**



Clip for direct ceiling attachment (4u.)
Clip de fixation directe au plafond (4 u.)

14 ○ **71-8197-14-00**

60 ● **71-8197-60-00**



Fixed bars 1000mm (2u.)
Barres fixes 1000mm (2u.)

14 ○ **71-B503-14-00**

60 ● **71-B503-60-00**



Fixed bar installation kit 1000mm (2u.)
Kit de rallonge à barre fixe 1 000 mm (2u.)

14 ○ **71-B504-14-00**

60 ● **71-B504-60-00**

Decorative accessories

Accessoires décoratifs













End cap (1u.)
Cache final (1 u.)

14 ○ **71-7537-14-00**

60 ● **71-7537-60-00**

Joint accessories
Accessoires de raccord

	DALI "L" right connector Connecteur gauche en « L » DALI	14 ○ 71-7543-14-00
		60 ● 71-7543-60-00
	DALI "L" left connector Connecteur gauche en « L » DALI	14 ○ 71-7542-14-00
		60 ● 71-7542-60-00
	DALI "T" right connector Connecteur droit en « T » DALI	14 ○ 71-7545-14-00
		60 ● 71-7545-60-00
	DALI left "T" connector Connecteur gauche en « T » DALI	14 ○ 71-7544-14-00
		60 ● 71-7544-60-00
	DALI left "T" connector Connecteur gauche en « T » DALI	14 ○ 71-7539-14-00
		60 ● 71-7539-60-00
	DALI right connector Connecteur droit DALI	14 ○ 71-7538-14-00
		60 ● 71-7538-60-00
	DALI left connector Connecteur gauche DALI	14 ○ 71-7541-14-00
		60 ● 71-7541-60-00
	DALI "I" connector Connecteur en « I » DALI	14 ○ 71-7546-14-00
		60 ● 71-7546-60-00
	DALI "X" connector Connecteur en « X » DALI	14 ○ 71-7547-14-00
		60 ● 71-7547-60-00
	DALI flexible connector Connecteur flexible DALI	14 ○ 71-7540-14-00
		60 ● 71-7540-60-00

Connective controllers
Contrôleurs connectés

P. 969

 **Consult the available control systems / Consultez les systèmes de contrôle disponibles:**
 DALI2 / DALI2
 Bluetooth wireless / Sans fil Bluetooth
 Autonomous / Autonome

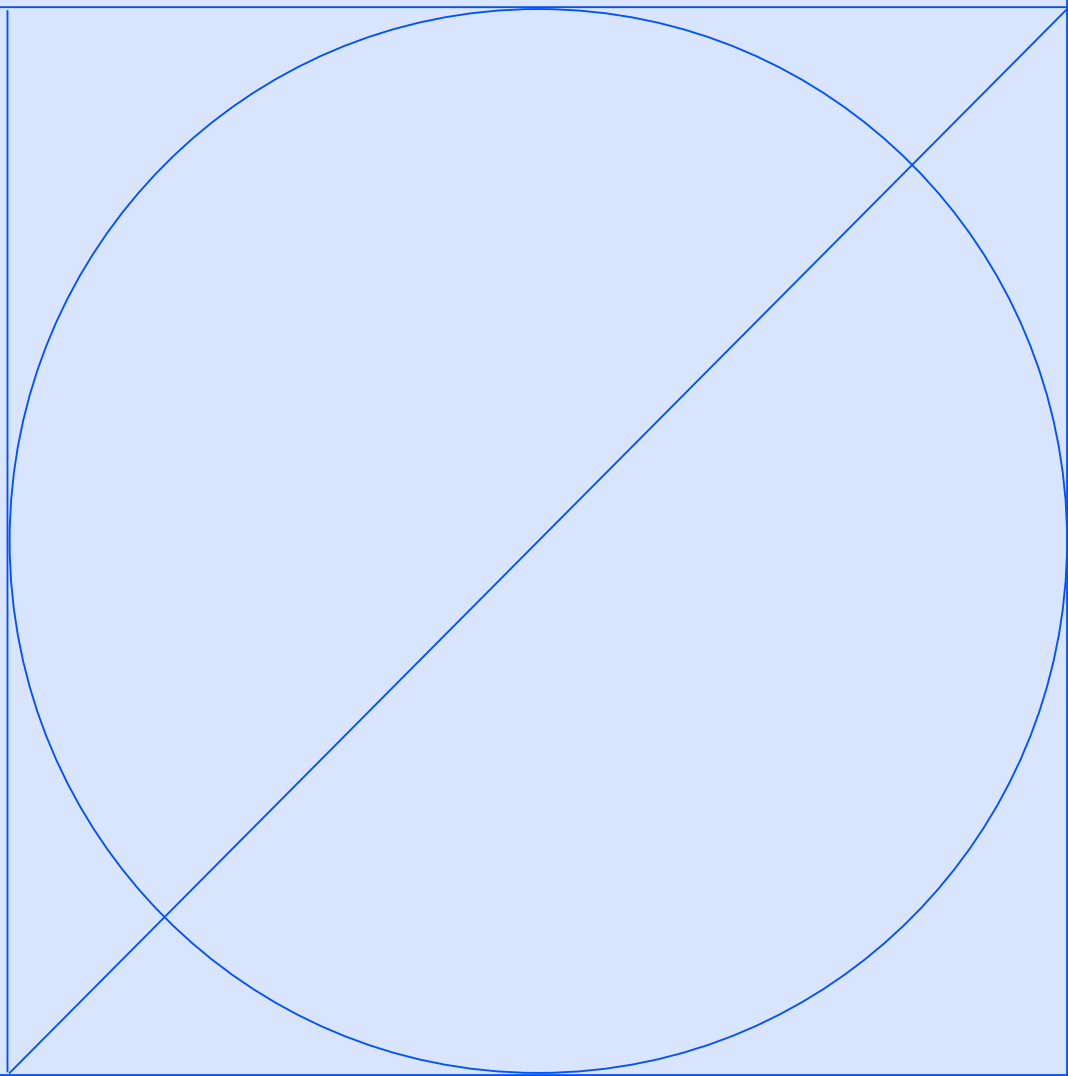

LV

Low Voltage

Basse tension

Atom LV

114

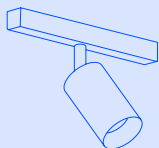

Kiva LV

118

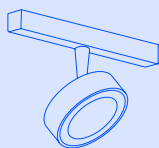

Iris LV

120

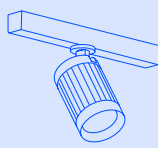

Tango LV

124

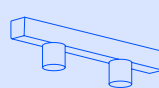

Bento LV

126

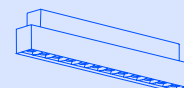

Nara LV

128

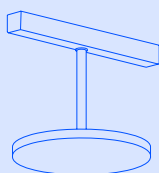

On LV

130

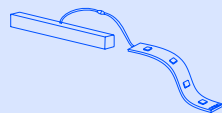

Infinite LV

132



Track LV

134

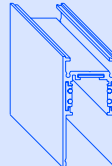

Track LV Hyperlink

138

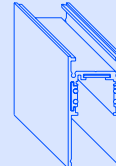

Low Voltage
Atom

114

Ø 30 mm



Ø 52 mm



Low Voltage
Kiva

118

Ø 75 mm



Ø 95 mm



Low Voltage
Iris

120

Ø 55 mm

Spotlight



Ø 55 mm

Downlight



Ø 55 mm

Pendant



Low Voltage
Tango

134

Ø 22 mm



Ø 22 mm



Low Voltage
Bento

126

99 mm

Standard



194 mm



125 mm

Adjustable



220 mm



142 mm

Wall Washer



274 mm



3.1 - 12.1 W



Ultra Spot 8°
Ultra Flood 43°



6.4 - 12 W



Ultra Medium 24°



6 - 18 W



Extra Spot 15°
Ultra Flood 50°



1.4- 2.8 W



Medium 23°



6 - 12 W



Ultra Medium 25°
Wall Washer



Low Voltage
Infinite
132

462 mm



950 mm



464 mm

High output



950 mm



Low Voltage
On
130

500 mm



1000 mm



2000 mm



3000 mm



Low Voltage
Nara
128

Ø 157 mm



Low Voltage
Track Standard
134

Surface



Pendant



Recessed



Up&Down



Low Voltage
Track Hyperlink
138

Surface



Pendant



Recessed



6.5 - 13 W



Flood 92°

●
60

3.9 - 19.2 W

○
14

13.4 W

○ ●
14 60

○ ●
14 60

●
60



Low Voltage



This is a multi-purpose system based on a 48V profile and various lighting solutions, including spotlights, pendant lights and linear lighting. It can be installed both vertically and horizontally, and has recessed, surface and hanging versions. The Low Voltage system offers designers plenty of freedom as it can illuminate changing, versatile spaces. By adjusting and moving the light points, they can be adapted to changing lighting requirements.

Système polyvalent basé sur la combinaison d'un profil, alimenté à 48 V, avec différentes solutions d'éclairage telles que des projecteurs, des suspensions et des linéaires. Il peut être installé verticalement ou horizontalement et existe en version encastrée, de surface et suspendue. Le système Low Voltage offre une grande liberté au concepteur, lui permettant d'éclairer des espaces changeants et polyvalents, en ajustant et déplaçant les points lumineux pour les adapter aux exigences de chaque moment.



Atom

Two sizes and finishes
Essence
Deux tailles et finitions
Essence



Manual zoom Zoom manuel

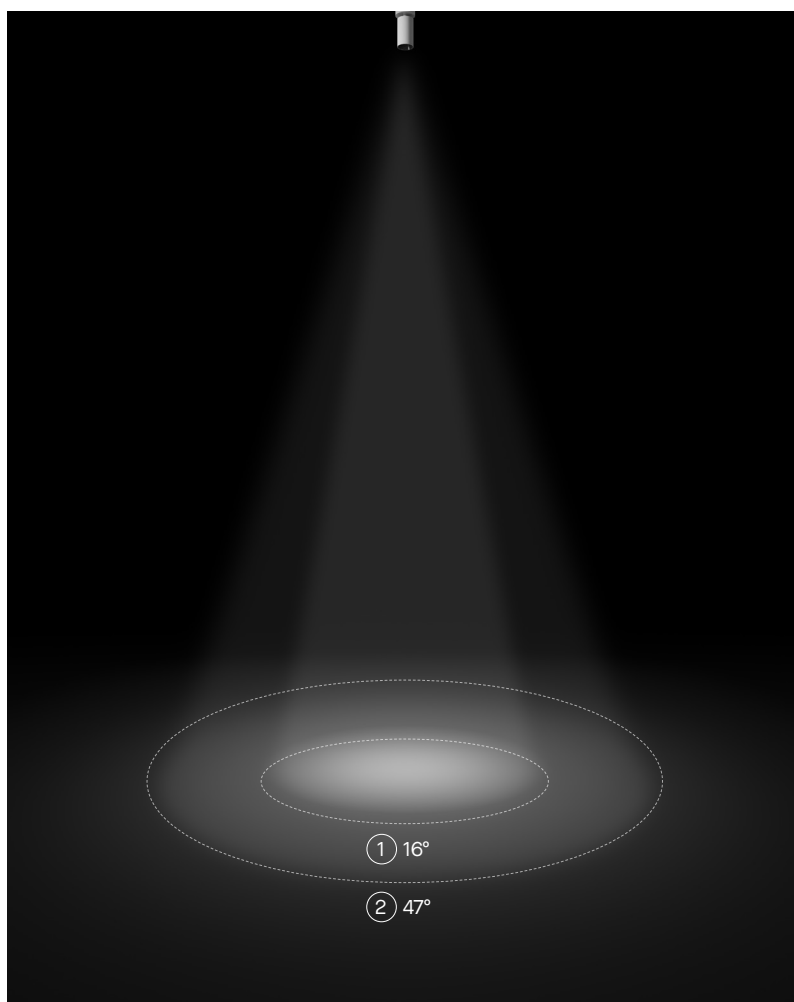
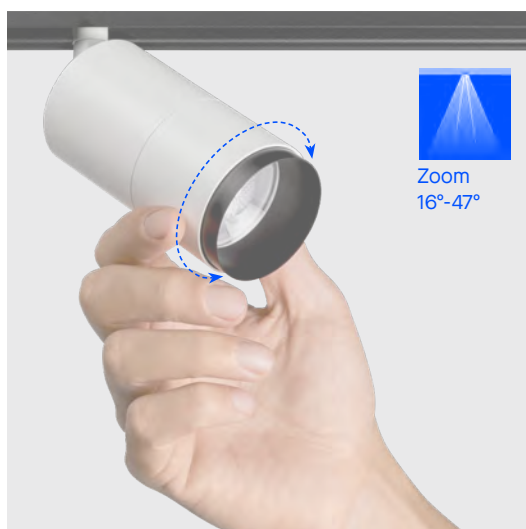





Atom Low Voltage 52 and **Bento Low Voltage** in Curly Lab Barcelona. Interior design: Miriam Barrios. Photography: Salva Lopez.
Atom Low Voltage 52 et **Bento Low Voltage**, Curly Lab Barcelona. Architecture d'intérieur : Miriam Barrios. Photographie : Salva Lopez.



Bento Standard on Low Voltage rail for a private residence project in Barcelona.
Bento Standard sur rail basse tension pour un projet de résidence privée à Barcelone.

Kiva

Is available in 4 finishes that adapt to the environment, offering all-important versatility in retail settings or for exhibitions

Est disponible en 4 finitions qui s'adaptent au décor avec la flexibilité nécessaire dans les espaces Retail (commerce de détail) ou d'exposition

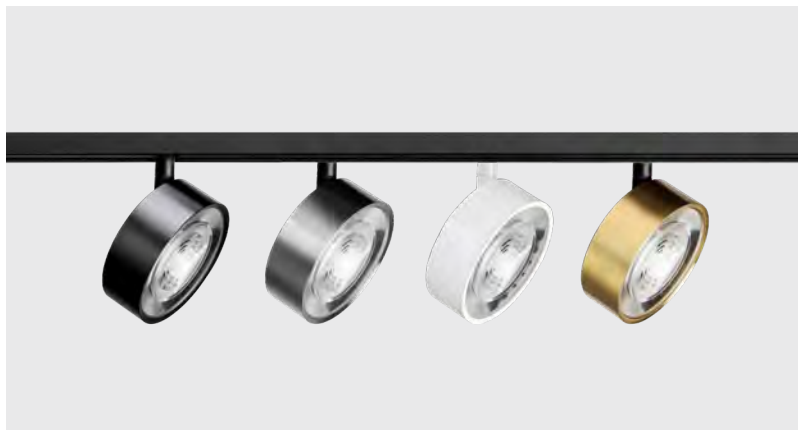

Available in white, black, satin nickel and gold finish.
Disponible en finition blanche, noire, nickel satiné et or.

Longitudinal and swivel rotation Rotation longitudinale et pivotante





Kiva Low Voltage in meeting room at the Fundación ONCE. Highly efficient light intensity control.

Photography: Álvaro Valdecantos.

Kiva Low Voltage en salle de réunion dans la fondation ONCE. Éclairage contrôlé avec un haut niveau d'efficacité.

Photographie : Álvaro Valdecantos.

Iris

Modularity of
components and
finishes

Modularité des
composants et des
finitions

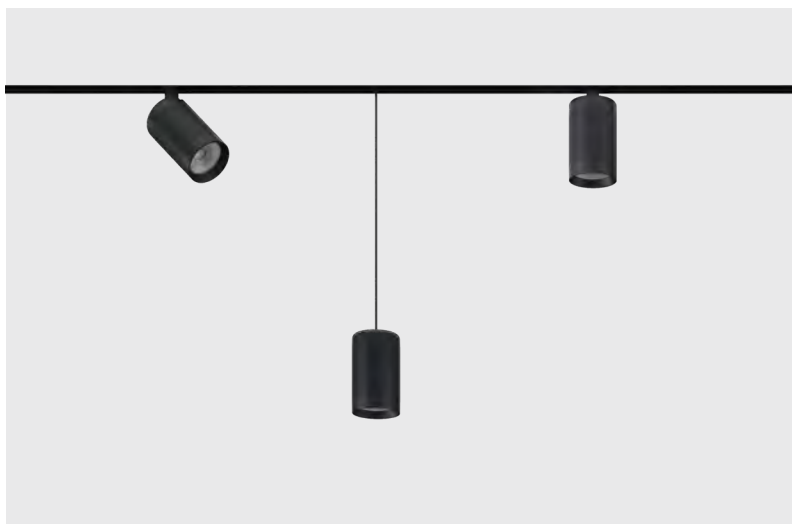

Iris Low Voltage, in versions of up to 18W, is available as a spotlight, pendant light and downlight.

En versions allant jusqu'à 18 W, Iris Low Voltage est proposé sous forme de projecteur, de suspension et de downlight.



* All finishes are combined with transparent glass.

* Toutes les finitions sont combinées avec du verre transparent.



Iris Low Voltage pendant is an ideal option for spaces such as restaurants that are looking for a technical solution, with comfort and control, as well as decorative

La suspension Iris Low Voltage est une option idéale pour les espaces tels que les restaurants qui recherchent une solution technique, avec confort et contrôle, ainsi que décoratif

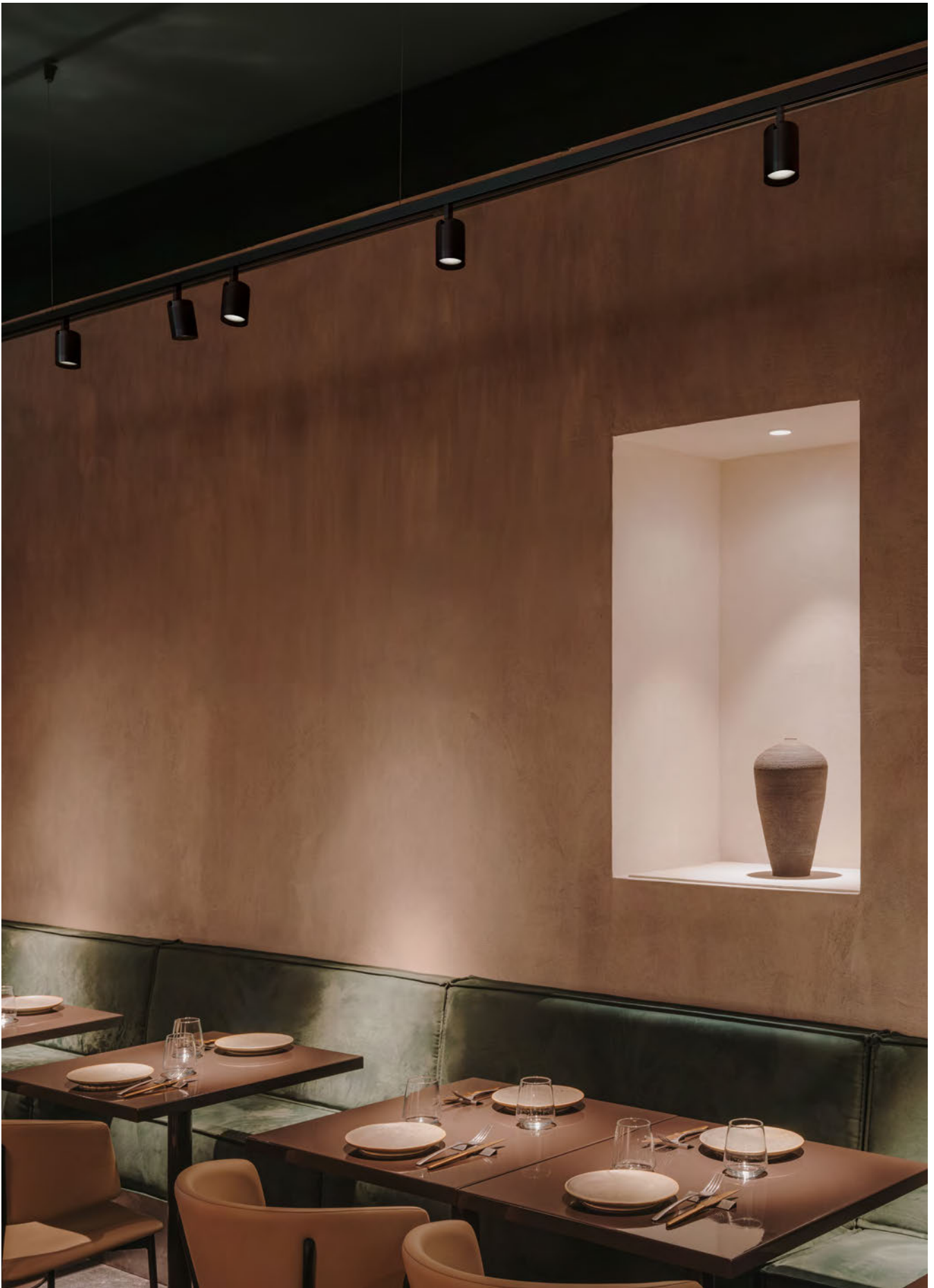



Tango

The compact double or single spotlights are discreetly concealed within the track, providing excellent lighting while going virtually unnoticed.

Les projecteurs, doubles ou individuels, se cachent discrètement et avec leur taille très compacte dans le rail, ils éclairent ce qui les entoure tout en passant pratiquement inaperçus.

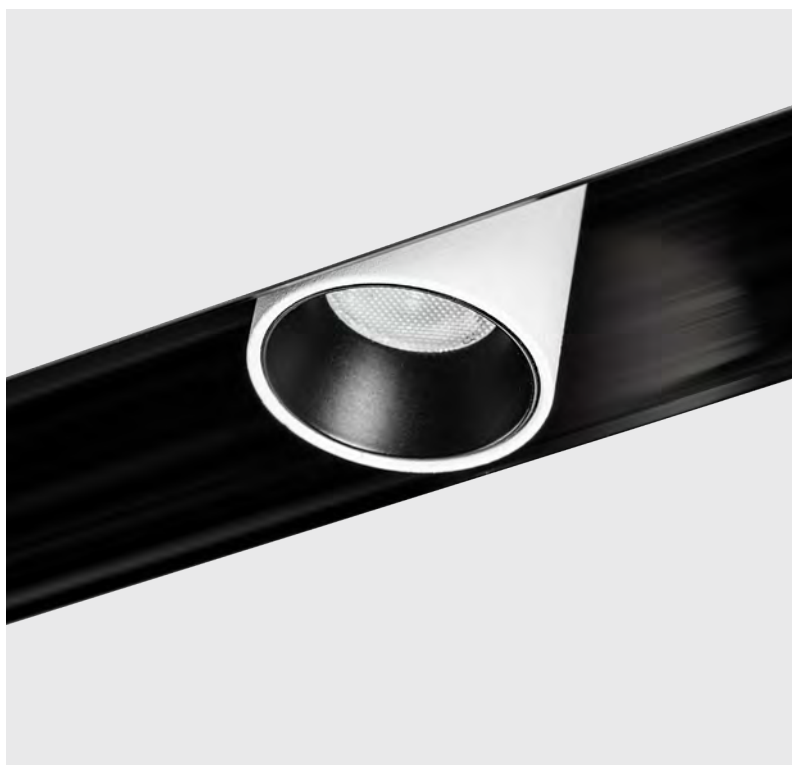

Tango is an ideal solution for restaurant and retail environments.

Les modèles Tango offrent une solution idéale pour les décors de restaurants et commerces.







Bento

Comes in Standard, Adjustable and Wall Washer versions to create a perfect wall-washing lighting effect
Est proposé en version Standard, Adjustable et Wall washer, pour un effet lèche-mur parfait

Bento Low Voltage Adjustable

Micro-engraved spoon-shaped reflectors for a homogeneous bathing
Réflecteurs micro-gravés en forme de cuillère pour un revêtement homogène



Bento Low Voltage Wall Washer



Bento Low Voltage in Oficinas Taulat, 19. Barcelona. Architecture: aaa Barcelona by Ignacio Infiesta. Photography: Javier Márquez.

Bento Low Voltage. Oficinas Taulat, 19. Barcelone. Architecture : aaa Barcelona par Ignacio Infiesta. Photographie : Javier Márquez.



Bento Low Voltage
Standard

Nara

Technical and decorative
solution with many
possibilities

Solution technique
et décorative avec de
nombreuses possibilités



Felt accessories in dark grey and light grey finishes grant the collection an extra aesthetic element, making it an excellent choice for retail and contract settings.

Les accessoires en feutre en finitions gris foncé et gris clair apportent un plus esthétique à la collection qui est très apprécié dans les domaines Retail (commerce de détail) et Contract (hôtels et bureaux).







On

LED strip for Track, Up & Down and pendant profiles, perfect for illuminating ceilings and adding a sense of spaciousness to spaces
Ruban LED pour profilé Track, Up & Down et suspension, idéal pour éclairer les plafonds en apportant un plus d'espace aux lieux





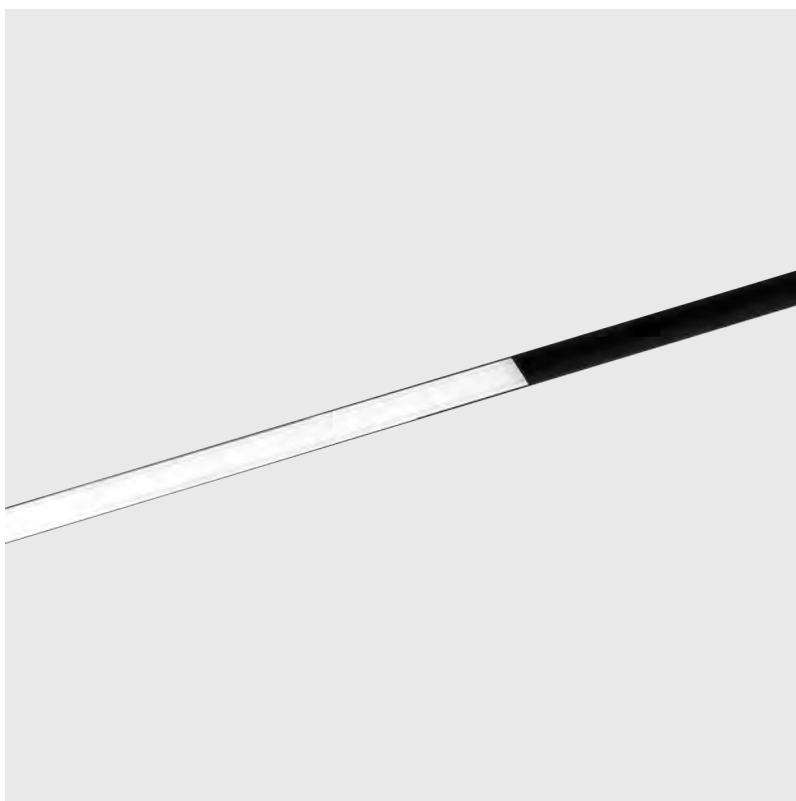

Infinite

Linear and homogeneous
lighting homogeneous
integrated in the
the low-voltage rail
Éclairage linéaire et
homogène intégré dans un
rail basse tension

The High Output model boasts a
luminous output of over 2,400 lm/W
Le modèle à haut rendement fournit une
charge lumineuse de plus de 2 400 lm/W



Track Standard

Compact profile available in a variety of applications – recessed, surface mounted, pendant and Up & Down

Porteur compact disponible dans différentes applications encastrées, en saillie, suspendues et Up & Down

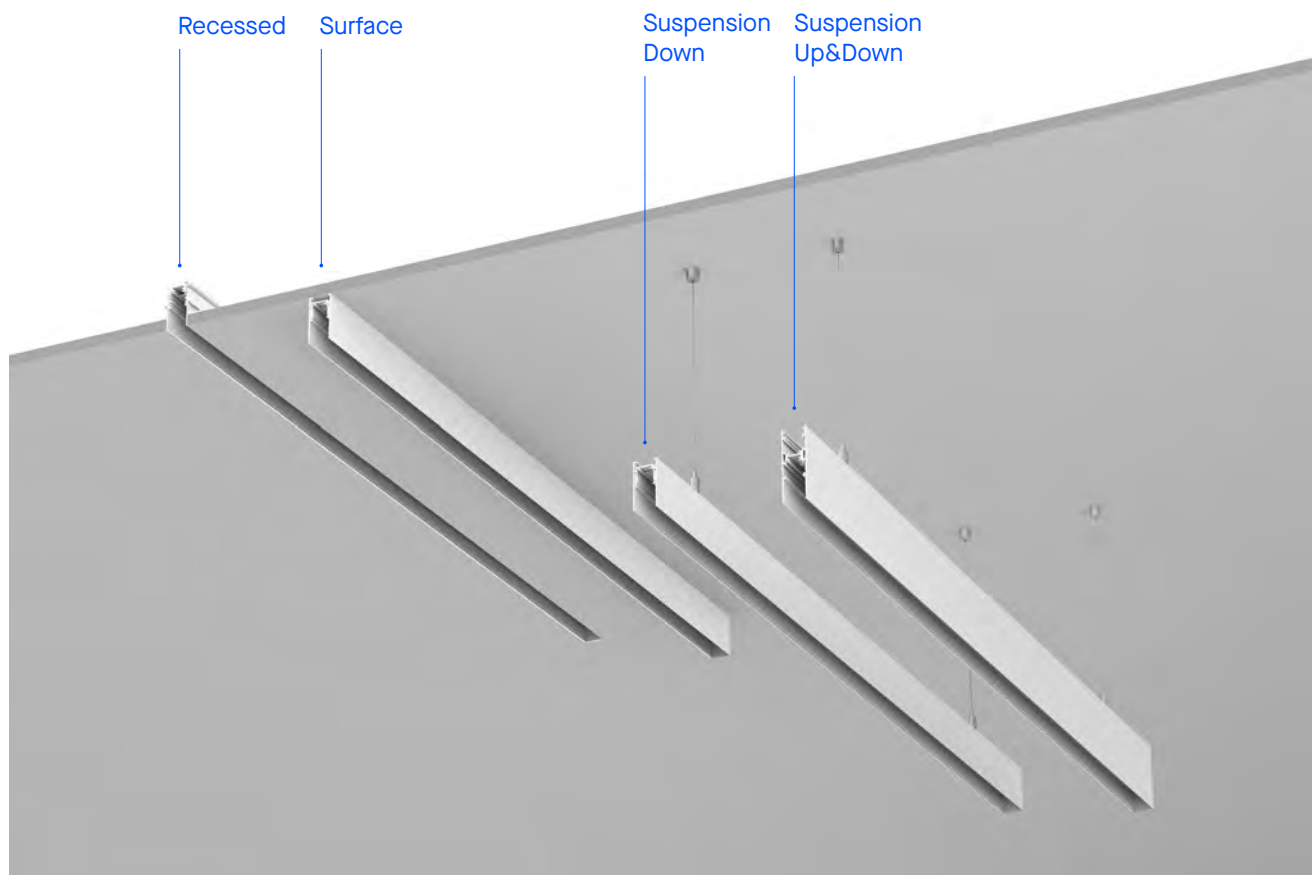

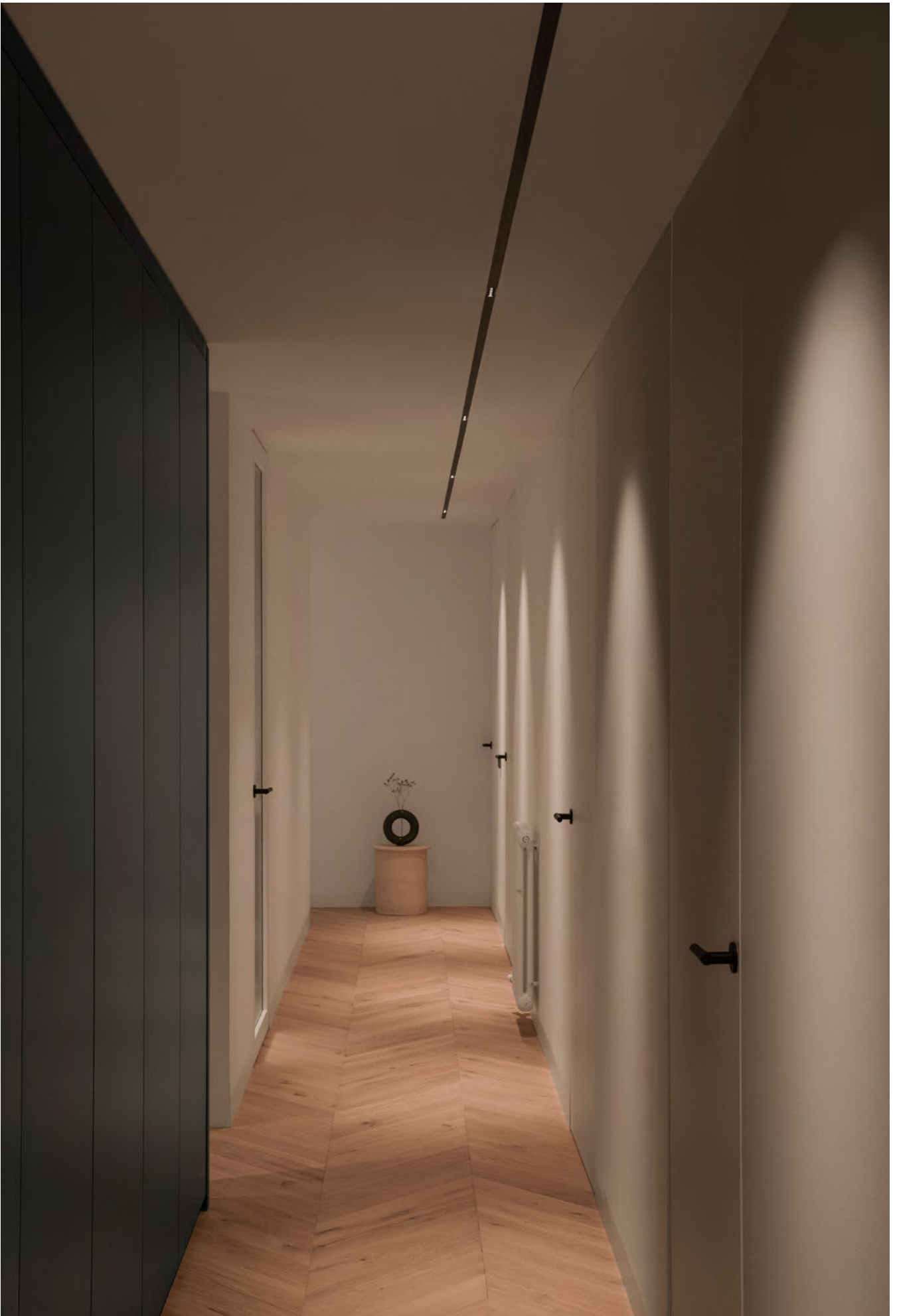

Bento Low Voltage on recessed track. Private residence in Barcelona. Architecture: aaa Barcelona by Ignacio Infiesta. Photography: Javier Márquez.

Bento Low Voltage sur rail encastré. Résidence privée à Barcelone. Architecture : aaa Barcelona par Ignacio Infiesta. Photographie : Javier Márquez.

Track Surface Standard



① Power source, end cap and power connector



② I Joint



③ T Joint



④ X Joint

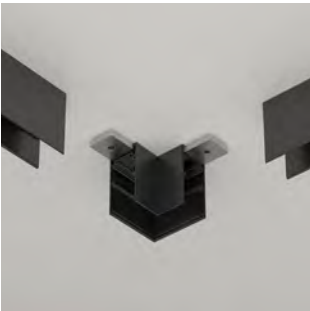

⑤ L Joint



⑥ External vertical L Joint



⑦ Internal Vertical L Joint

Track Hyperlink



① Power source
End cap
Power connector



② T Joint



③ T 60° Joint



④ 120° Joint



⑤ End cap



⑥ X Joint

Profile available in pendant, recessed and surface-mounted applications, with connections of up to 6 nodes, expanding installation possibilities.

Profilé disponible en version suspendue, encastrée et de surface, avec des raccords comprenant jusqu'à 6 nœuds, ce qui élargit les possibilités d'installation.



⑦ I Joint



⑧ Internal Vertical L Joint



⑨ External Vertical L Joint



⑩ O Joint



⑪ L horizontal joint

Smart functionality Fonctionnalité Smart



Lighting scene Ambiances lumineuses

Smart technology applied to the Low Voltage range makes it possible to control the luminaires and adapt them to project requirements. With Bluetooth Mesh connection, they can be individually programmed to create more precise atmospheres in environments that require it.

Appliquée à Low Voltage, la technologie intelligente, dite "Smart", permet de contrôler les luminaires pour s'adapter aux besoins du projet. Dans le cas de la connexion via Bluetooth Mesh, ils peuvent être programmés individuellement pour créer des ambiances plus précises dans les espaces qui le nécessitent.

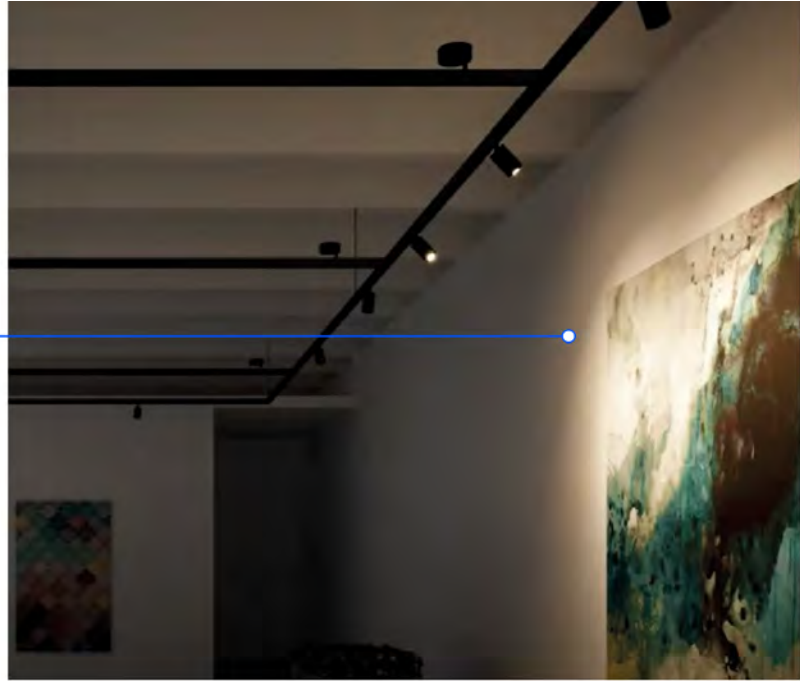

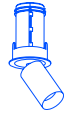

Atom Low Voltage Ø30

BODY MAT AL	DIF MAT PC		WELL	2 MacAdam				
----------------	---------------	--	------	--------------	--	--	--	--

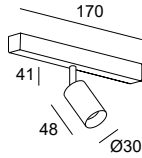
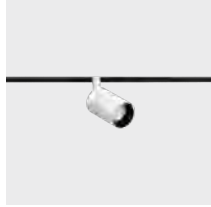

LED								48 VDC
K	CRI	W	Real Lm	Optics	Code			
2700	90	3.1	269	37°	35-7285	14 - OO	ON-OFF 48 VDC	
						60 - DA	DALI 48 VDC	
						60 - XB	CASAMBI 48 VDC	
3000	90	3.1	364	37°	35-7286	14 - OO	ON-OFF 48 VDC	
						60 - DA	DALI 48 VDC	
						60 - XB	CASAMBI 48 VDC	

Atom Low Voltage Ø52

BODY MAT AL	DIF MAT PC		WELL	2 MacAdam				
----------------	---------------	--	------	--------------	--	--	--	--

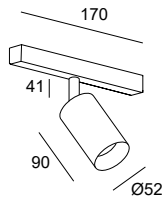
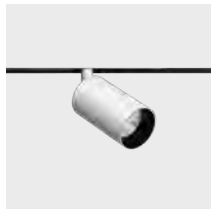

LED								48 VDC
K	CRI	W	Real Lm	Optics	Code			
2700	90	8.2	428	8°	35-A072	14 - OO	ON-OFF 48 VDC	
						60 - DA	DALI 48 VDC	
						81 - XB	CASAMBI 48 VDC	
						DN		
2700	90	11.8	1153	22°	35-7279	14 - OO	ON-OFF 48 VDC	
						60 - DA	DALI 48 VDC	
						81 - XB	CASAMBI 48 VDC	
2700	90	11.8	1289	35°	35-7280	14 - OO	ON-OFF 48 VDC	
						60 - DA	DALI 48 VDC	
						81 - XB	CASAMBI 48 VDC	
2700	90	11.8	1264	43°	35-7281	14 - OO	ON-OFF 48 VDC	
						60 - DA	DALI 48 VDC	
						81 - XB	CASAMBI 48 VDC	
2700	90	17.3	1547	22°	35-A214	14 - OO	ON-OFF 48 VDC	
						60 - DA	DALI 48 VDC	
						81 - XB	CASAMBI 48 VDC	
2700	90	17.3	1766	35°	35-A215	14 - OO	ON-OFF 48 VDC	
						60 - DA	DALI 48 VDC	
						81 - XB	CASAMBI 48 VDC	
2700	90	17.3	1713	43°	35-A216	14 - OO	ON-OFF 48 VDC	
						60 - DA	DALI 48 VDC	
						81 - XB	CASAMBI 48 VDC	
3000	90	8.2	437	8°	35-A073	14 - OO	ON-OFF 48 VDC	
						60 - DA	DALI 48 VDC	
						81 - XB	CASAMBI 48 VDC	
						DN		
3000	90	11.8	1200	22°	35-7282	14 - OO	ON-OFF 48 VDC	
						60 - DA	DALI 48 VDC	
						81 - XB	CASAMBI 48 VDC	
3000	90	11.8	1342	35°	35-7283	14 - OO	ON-OFF 48 VDC	
						60 - DA	DALI 48 VDC	
						81 - XB	CASAMBI 48 VDC	
3000	90	11.8	1316	43°	35-7284	14 - OO	ON-OFF 48 VDC	
						60 - DA	DALI 48 VDC	
						81 - XB	CASAMBI 48 VDC	
3000	90	17.3	1610	22°	35-A217	14 - OO	ON-OFF 48 VDC	
						60 - DA	DALI 48 VDC	
						81 - XB	CASAMBI 48 VDC	
3000	90	17.3	1838	35°	35-A218	14 - OO	ON-OFF 48 VDC	
						60 - DA	DALI 48 VDC	
						81 - XB	CASAMBI 48 VDC	
3000	90	17.3	1783	43°	35-A219	14 - OO	ON-OFF 48 VDC	
						60 - DA	DALI 48 VDC	
						81 - XB	CASAMBI 48 VDC	

Atom Low Voltage Ø52 Zoom

BODY MAT AL	DIF MAT PC		WELL	2 MacAdam				
----------------	---------------	--	------	--------------	--	--	--	--

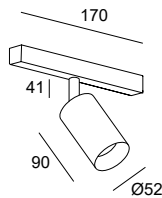

LED								48 VDC
K	CRI	W	Real Lm	Optics	Code			
2700	90	12.6	1113	Zoom 16°-47°	35-A063	14 - OO	ON-OFF 48 VDC	
						60 - DA	DALI 48 VDC	
						60 - XB	CASAMBI 48 VDC	
3000	90	12.6	1180	Zoom 16°-47°	35-A064	14 - OO	ON-OFF 48 VDC	
						60 - DA	DALI 48 VDC	
						60 - XB	CASAMBI 48 VDC	

Atom Low Voltage
30Atom Low Voltage
52Atom Low Voltage
52 Zoom**Lens accessories****Accessoires optiques**

	Elliptical diffuser (5u.) Diffuseur elliptique (5 u.)	-	-	71-6274-00-00	-
	Halo fader (5u.) Diffuseur de halo (5 u.)	-	-	71-6275-00-00	-
	Visual comfort (1u.) Confort visuel (1 u.)	14 ○	-	71-6276-14-00	-
		60 ●	-	71-6276-60-00	-
	Honeycomb panel (5u.) Grille en nid d'abeille (5 u.)	60 ●	-	71-6273-60-00	-
	Visor Visière	60 ●	-	71-6277-60-00	-
	Front ring Anneau frontal	14 ○	-	71-6436-14-00	-
		23 ●	-	71-6436-23-00	-

Connective controllers**Contrôleurs connectés**

P. 969

**Consult the available control systems / Consultez les systèmes de contrôle disponibles:**

DALI2 / DALI2

Bluetooth wireless / Sans fil Bluetooth

Autonomous / Autonome



Kiva Ø75

BODY MAT
AL

UGR
<16

DIF MAT
PC



2
MacAdam

360°



○ ● ● ● ●
14 60 81 DN

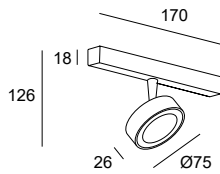

LED							48 VDC
K	CRI	W	Real Lm	Optics	Code		
2700	90	6.4	458	19°	35-8035	14 60 81 DN	OO - DA XB CASAMBI 48 VDC ⚡
3000	90	6.4	530	19°	35-8036	DN 14 60 81	OO - DA XB CASAMBI 48 VDC ⚡

Kiva Ø95

BODY MAT
AL

UGR
<16

DIF MAT
PC



2
MacAdam

360°



○ ● ● ● ●
14 60 81 DN

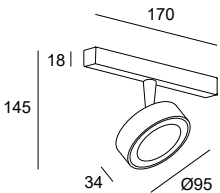

LED							48 VDC
K	CRI	W	Real Lm	Optics	Code		
2700	90	12	1172	23°	35-8037	14 60 81 DN	OO - DA XB CASAMBI 48 VDC ⚡
3000	90	12	1320	23°	35-8038	14 60 81 DN	OO - DA XB CASAMBI 48 VDC ⚡

Connective controllers Contrôleurs connectés

P. 969



Consult the available control systems / Consultez les systèmes de contrôle disponibles:

DALI2 / DALI2

Bluetooth wireless / Sans fil Bluetooth

Autonomous / Autonome

Iris

Designed by Artec Studio



Spotlight
P. 274



Pendant
P. 268



Ceiling
P. 274



Spotlight Surf.
P. 274



Iris Low Voltage

BODY MAT AL		50000h L80 B20	2 MacAdam	90°		
----------------	--	-------------------	--------------	-----	--	--

Code example / Exemple d'élaboration d'une référence: **AV19-P6V9U10S60**

Model		W	K	CRI	Optics	Real Lm		Source	Finishes
 Max. 130 Ø55 AV19 - Spotlight	P6V9	5.7	2700	90	U Hoop	533-750	1 15°	OS ON-OFF 48VDC	60 ●
	P6W9	5.7	3000	90	V Visual	249-357	2 35°	DS DALI-2 48VDC	
	P6X9	5.7	4000	90	X Cone	527-707	3 50°		
					Y Glass	382-461			
					Z Pipe	376-466			
 Max. 169 Ø55 AV23 - Downlight	12V9	11.8	2700	90	U Hoop	1183-1573	1 15°	OS ON-OFF 48VDC	60 ●
	12W9	11.8	3000	90	V Visual	518-689	2 35°	DS DALI-2 48VDC	
	12X9	11.8	4000	90	X Cone	1211-1477	3 50°		
					Y Glass	782-1023			
 Max. 2000 Ø55 AV24 - Pendant	18V9	17.3	2700	90	U Hoop	1592-2142	1 15°	OS ON-OFF 48VDC	60 ●
	18W9	17.3	3000	90	V Visual	711-939	2 35°	DS DALI-2 48VDC	
	18X9	17.3	4000	90	X Cone	1653-2037	3 50°		
					Y Glass	1071-1360			
					Z Pipe	1161-1422			



Finishes / Finitions

Selection of finishes available on the online configurator
 Sélection de finitions disponibles grâce au configurateur en ligne

Configurator
Configurateur
iris.ledsc4.com



Lens accessories Accessoires optiques

	Elliptical diffuser (5u.) Diffuseur elliptique (5 u.)	71-5167-00-00		Honeycomb panel (5u.) Grille en nid d'abeille (5 u.)	71-5166-60-00
	Square diffuser (5u.) Diffuseur carré (5 u.)	71-5658-00-00		Screen (5u.) Diffuseur (5 u.)	71-7895-60-00
	Halo fader (5u.) Diffuseur de halo (5 u.)	71-6099-00-00			



Tango 1 Spot

BODY MAT
AL

UGR
<10



3
MacAdam



14

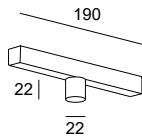

LED							48 VDC
K	CRI	W	Real Lm	Optics	Code		
2700	90	1.4	145	23°	35-A135 - 14	OO ON-OFF 48 VDC	DA DALI-2 48 VDC
						XB CASAMBI 48 VDC	
						OO ON-OFF 48 VDC	DA DALI-2 48 VDC
3000	90	1.4	152	23°	35-A136 - 14	OO ON-OFF 48 VDC	DA DALI-2 48 VDC
						XB CASAMBI 48 VDC	
						OO ON-OFF 48 VDC	DA DALI-2 48 VDC

Tango 2 Spots

BODY MAT
AL

UGR
<10



3
MacAdam



14

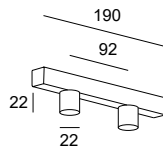
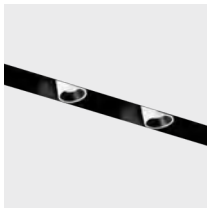

LED							48 VDC
K	CRI	W	Real Lm	Optics	Code		
2700	90	2.8	283	25°	35-A137 - 14	OO ON-OFF 48 VDC	DA DALI 48 VDC
						XB CASAMBI 48 VDC	
						OO ON-OFF 48 VDC	DA DALI 48 VDC
3000	90	2.8	297	25°	35-A138 - 14	OO ON-OFF 48 VDC	DA DALI 48 VDC
						XB CASAMBI 48 VDC	
						OO ON-OFF 48 VDC	DA DALI 48 VDC

Connective controllers Contrôleurs connectés

P. 969



Consult the available control systems / Consultez les systèmes de contrôle disponibles:

DALI2 / DALI2

Bluetooth wireless / Sans fil Bluetooth

Autonomous / Autonome

Bento

Designed by LedsC4 Architectural



Downlights P. 232
Ceilings P. 309



Bento Low Voltage

BODY MAT PC,AL	UGR <13		3 MacAdam		
-------------------	------------	--	--------------	--	--

Bento 6 LEDS

○ ●
14 60

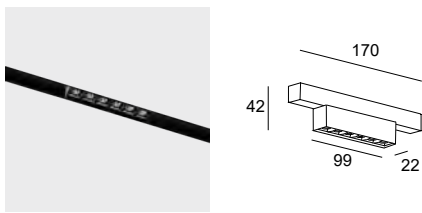

LED									48 VDC
K	CRI	W	Real Lm	Optics	Code				
2700	90	6	687	26°	15-7885	- 14	OO	ON-OFF 48V	
2700	90	6	603	47°	15-A041	- 60	- DA	DALI 48V	
							XB	CASAMBI 48V	
3000	90	6	687	26°	15-7886	- 14	OO	ON-OFF 48V	
3000	90	6	603	47°	15-A042	- 60	- DA	DALI 48V	
							XB	CASAMBI 48V	

Bento 12 LEDS

○ ●
14 60

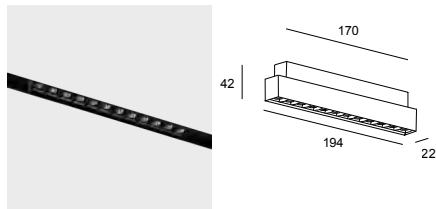

LED									48 VDC
K	CRI	W	Real Lm	Optics	Code				
2700	90	12	1374	26°	15-7888	- 14	OO	ON-OFF 48V	
2700	90	12	1205	47°	15-A043	- 60	- DA	DALI 348V	
							XB	CASAMBI 48V	
3000	90	12	1374	26°	15-7889	- 14	OO	ON-OFF 48V	
3000	90	12	1205	47°	15-A044	- 60	- DA	DALI 48V	
							XB	CASAMBI 48V	

Bento

Low Voltage Adjustable



BODY MAT
PC,AL

UGR
<13



3
MacAdam

LV

INDOOR

LOW VOLTAGE | BASSE TENSION

147

Bento 6 LEDs

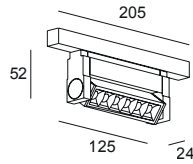

○ ●
14 60

LED										48 VDC
K	CRI	W	Real Lm	Optics	Code					
2700	90	6.3	687	26°	35-A158	- 14	OO	ON-OFF	48 VDC	
2700	90	6.3	603	47°	35-A162	- 60	- DA	DALI	48 VDC	
							XB	CASAMBI	48 VDC	⚡
3000	90	6.3	687	26°	35-A159	- 14	OO	ON-OFF	48 VDC	
3000	90	6.3	603	47°	35-A163	- 60	- DA	DALI	48 VDC	
							XB	CASAMBI	48 VDC	⚡

Bento 12 LEDs

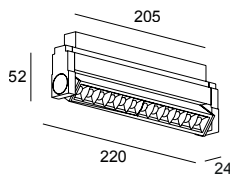

○ ●
14 60

LED										48 VDC
K	CRI	W	Real Lm	Optics	Code					
2700	90	12.6	1374	26°	35-A160	- 14	OO	ON-OFF	48 VDC	
2700	90	12.6	1205	47°	35-A164	- 60	- DA	DALI	48 VDC	
							XB	CASAMBI	48 VDC	⚡
3000	90	12.6	1374	26°	35-A161	- 14	OO	ON-OFF	48 VDC	
3000	90	12.6	1205	47°	35-A165	- 60	- DA	DALI	48 VDC	
							XB	CASAMBI	48 VDC	⚡

Bento

Low Voltage Wallwasher

BODY MAT
PC,AL

UGR
<13



3
MacAdam



Bento Wallwasher 6 LEDs

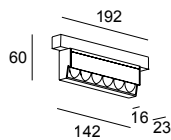
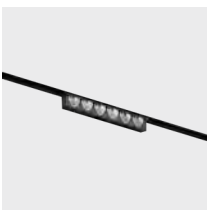

○ ●
14 60

LED										48 VDC
K	CRI	W	Real Lm	Code						
2700	90	6	421	15-A149	- 14	OO	ON-OFF	48V		
					- 60	- DA	DALI	48V		
						XB	CASAMBI	48V	⚡	
3000	90	6	468	15-A150	- 14	OO	ON-OFF	48V		
					- 60	- DA	DALI	48V		
						XB	CASAMBI	48V	⚡	

Bento Wallwasher 12 LEDs

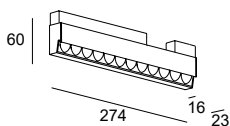

○ ●
14 60

LED										48 VDC
K	CRI	W	Real Lm	Code						
2700	90	12	829	15-A151	- 14	OO	ON-OFF	48V		
					- 60	- DA	DALI	348V		
						XB	CASAMBI	48V	⚡	
3000	90	12	921	15-A152	- 14	OO	ON-OFF	48V		
					- 60	- DA	DALI	48V		
						XB	CASAMBI	48V	⚡	

Connective controllers Contrôleurs connectés

P. 969



Consult the available control systems / Consultez les systèmes de contrôle disponibles:

DALI2 / DALI2

Bluetooth wireless / Sans fil Bluetooth

Autonomous / Autonome

Nara

Designed by LedsC4 Architectural

Nara

BODY MAT AL	DIF MAT ACR		3 MacAdam	50000h L80 B20	 30°			
----------------	----------------	--	--------------	-------------------	---------	--	--	--

○ ●
14 60

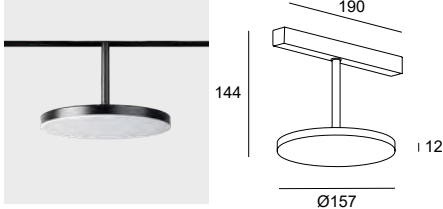

LED						48VDC	
K	CRI	W	Real Lm	Code			
2700	90	13.4	1074	35-A156	14	OO	ON-OFF 48 VDC
					60	- DA	DALI 48 VDC
						XB	CASAMBI 48 VDC
3000	90	13.4	1130	35-A157	14	OO	ON-OFF 48 VDC
					60	- DA	DALI 48 VDC
						XB	CASAMBI 48 VDC

Lens accessories

Accessoires optiques



Textile bell light accessory, light grey
Accessoire de cloche textile, gris clair

EK ● **71-B233-05-EK**



Textile bell light accessory, dark grey
Accessoire de cloche textile, gris foncé

EQ ● **71-B233-05-EQ**

Connective controllers

Contrôleurs connectés

P. 969



Consult the available control systems / Consultez les systèmes de contrôle disponibles:
DALI2 / DALI2
Bluetooth wireless / Sans fil Bluetooth
Autonomous / Autonome



On 500mm



50000h
L80 B20

3
MacAdam

IP
54

LOW
FLICKER

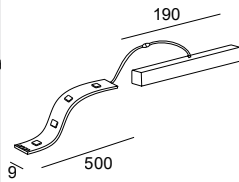

LED					48 VDC
K	CRI	W	Real Lm	Code	
2700	90	3.9	407	91-A027 - 00 - DA	
3000	90	3.9	420	91-A028 - 00 - DA	

On 1000mm



50000h
L80 B20

3
MacAdam

IP
54

LOW
FLICKER

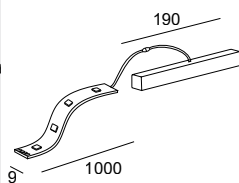

LED					48 VDC
K	CRI	W	Real Lm	Code	
2700	90	5.5	574	91-A029 - 00 - DA	
3000	90	5.5	592	91-A030 - 00 - DA	

On 2000mm



50000h
L80 B20

3
MacAdam

IP
54

LOW
FLICKER

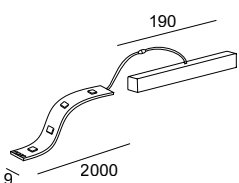

LED					48 VDC
K	CRI	W	Real Lm	Code	
2700	90	11.5	1201	91-A031 - 00 - DA	
3000	90	11.5	1238	91-A032 - 00 - DA	

On 3000mm



50000h
L80 B20

3
MacAdam

IP
54

LOW
FLICKER

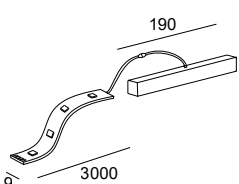

LED					48 VDC
K	CRI	W	Real Lm	Code	
2700	90	19.2	2006	91-A033 - 00 - DA	
3000	90	19.2	2068	91-A034 - 00 - DA	

Fixing accessories Accessoires de fixation



Cuttable profile for installation on Up & Down track (L=3000 mm)
Profilé découpable pour installation sur rail Up & Down (L=3000 mm)

71-B350-00-00

Infinite Pro LV

Infinite Pro
P. 338



Designed by LedsC4 Architectural



Infinite Standard 494mm

BODY MAT	DIF MAT		3	50000h	WELL
AL	PVC		MacAdam	L80 B20	

60

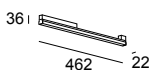
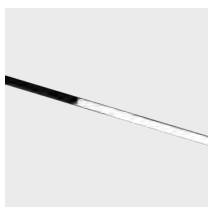

LED						48 VDC
K	CRI	W Total	Real Lm	Code		
2700	90	6.8	654	90-7359 - 60	OO ON-OFF 48 VDC	
					DA DALI 48 VDC	
					XB CASAMBI 48 VDC	
3000	80	6.8	654	90-7361 - 60	DA ON-OFF 48 VDC	
					OO DALI 48 VDC	
					XB CASAMBI 48 VDC	

Infinite Standard 988mm

BODY MAT	DIF MAT		3	50000h	WELL
AL	PVC		MacAdam	L80 B20	

60

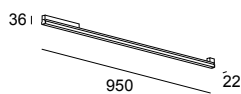
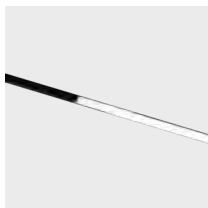

LED						48 VDC
K	CRI	W Total	Real Lm	Code		
2700	90	12.6	1208	90-7360 - 60	OO ON-OFF 48 VDC	
					DA DALI 48 VDC	
					XB CASAMBI 48 VDC	
3000	90	12.6	1208	90-7362 - 60	OO ON-OFF 48 VDC	
					DA DALI 48 VDC	
					XB CASAMBI 48 VDC	

Connective controllers Contrôleurs connectés

P. 969



Consult the available control systems / Consultez les systèmes de contrôle disponibles:

DALI2 / DALI2

Bluetooth wireless / Sans fil Bluetooth

Autonomous / Autonome

Infinite High Output 462mm

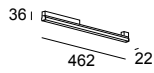
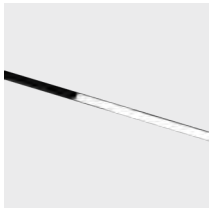

LED						48 VDC
K	CRI	W Total	Real Lm	Code		
2700	90	12.6	1361	90-A063 - 60	OO	ON-OFF 48 VDC
					DA	DALI 48 VDC
					XB	CASAMBI 48 VDC
3000	90	12.6	1353	90-A064 - 60	OO	ON-OFF 48 VDC
					DA	DALI 48 VDC
					XB	CASAMBI 48 VDC

Infinite High Output 950mm

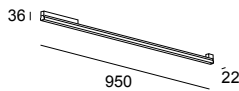
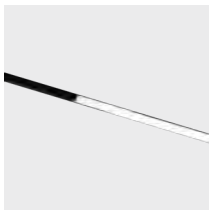

LED						48 VDC
K	CRI	W Total	Real Lm	Code		
2700	90	25.2	2715	90-A065 - 60	OO	ON-OFF 48 VDC
					DA	DALI 48 VDC
					XB	CASAMBI 48 VDC
3000	90	25.2	2697	90-A066 - 60	OO	ON-OFF 48 VDC
					DA	DALI 48 VDC
					XB	CASAMBI 48 VDC

Connective controllers
Contrôleurs connectés

P. 969



Consult the available control systems / Consultez les systèmes de contrôle disponibles:
DALI2 / DALI2
Bluetooth wireless / Sans fil Bluetooth
Autonomous / Autonome

Track Low Voltage Surfaced

Installation diagram
Schéma d'installation

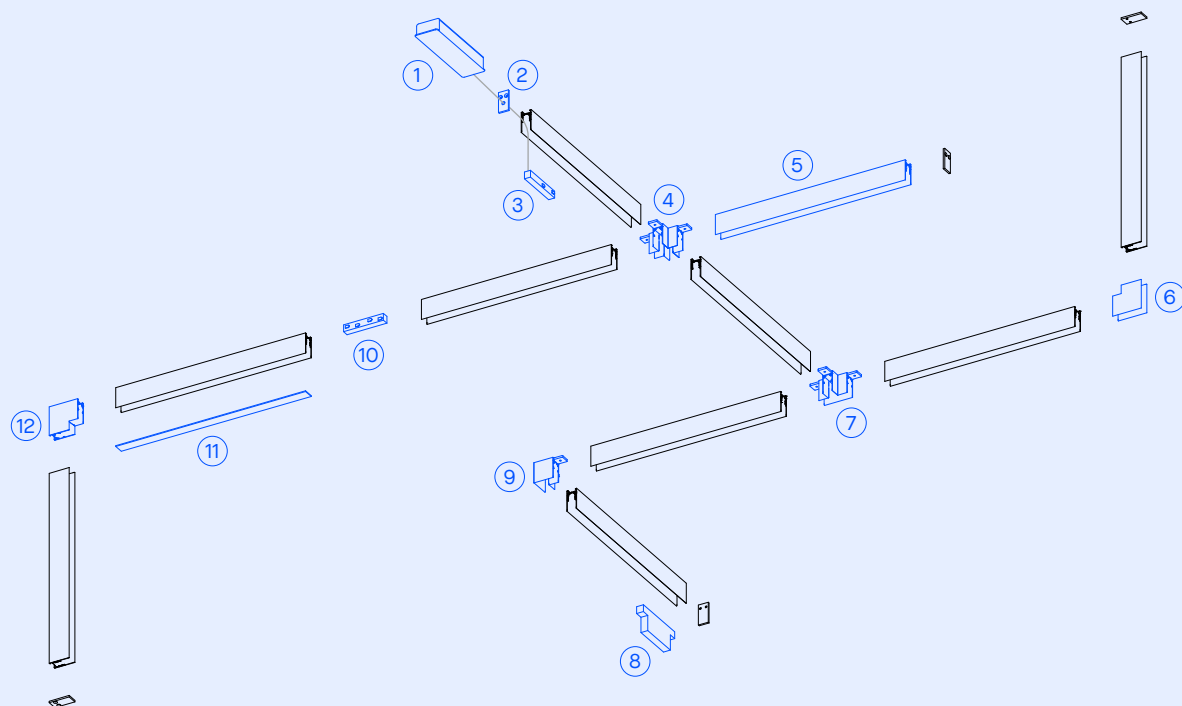

① Remote power source

71-A258-00-00
(48V / 75W)
71-A259-00-00
(48V / 120W)
71-B658-00-00
(160W IP20)
71-B659-00-00
(250W IP20)
71-B077-00-00
(48V / 320W)
71-B078-00-00
(48V / 480W)
71-B079-00-00
(48V / 620W)

Built-in power source

71-B440-60-00
(48V / 100W)
71-B441-60-00
(48V / 250W)

② Cap with hole

71-7705-00-00
71-7705-14-00
Cap without hole
71-A334-00-00
71-A334-14-00

③ Power connector

71-7637-60-00
71-7637-14-00

④ X joint

71-A247-60-00
71-A247-14-00

⑤ Track Low Voltage

1m: **71-7624-60-00**
71-7624-14-00
2m: **71-7625-60-00**
71-7625-14-00
3m: **71-7626-60-00**
71-7626-14-00

⑥ External Vertical L joint

71-A245-60-00
71-A245-14-00

⑦ T joint

71-A246-60-00
71-A246-14-00

⑧ Converter Casambi DALI

71-8115-00-00

⑨ Horizontal L joint

71-7627-60-00
71-7627-14-00

⑩ I joint

71-7639-60-00
71-7639-14-00

⑪ Decorative Caps

1m: **71-8030-60-00**
71-8030-14-00
2m: **71-8031-60-00**
71-8031-14-00
3m: **71-8032-60-00**
71-8032-14-00

⑫ Internal Vertical L joint

71-A244-60-00
71-A244-14-00

Track Low Voltage Pendant

LV

INDOOR

Installation diagram
Schéma d'installation

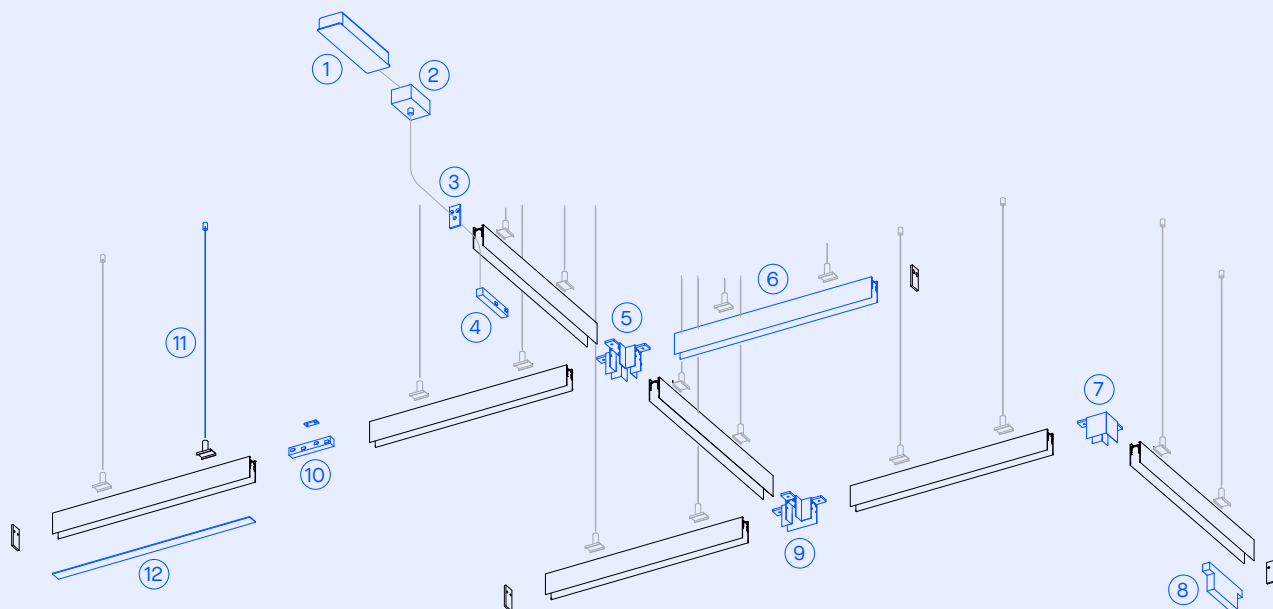

LOW VOLTAGE | BASSE TENSION

① Remote power source

71-A258-00-00
(48V / 75W)
71-A259-00-00
(48V / 120W)
71-B658-00-00
(160W IP20)
71-B659-00-00
(250W IP20)
71-B077-00-00
(48V / 320W)
71-B078-00-00
(48V / 480W)
71-B079-00-00
(48V / 620W)

Built-in power source

71-B440-60-00
(48V / 100W)
71-B441-60-00
(48V / 250W)

② Suspended ceiling

Rose power outlet
71-7520-60-00
71-7520-14-00

③ End Cap with hole

71-7705-00-00
71-7705-14-00
End Cap without hole
71-A334-00-00
71-A334-14-00

④ Power connector

71-7637-60-00
71-7637-14-00

⑤ X joint

71-A247-60-00
71-A247-14-00

⑥ Track Low Voltage

1m: **71-7624-60-00**
71-7624-14-00
2m: **71-7625-60-00**
71-7625-14-00
3m: **71-7626-60-00**
71-7626-14-00

⑦ Horizontal L joint

71-7627-60-00
71-7627-14-00

⑧ Converter Casambi DALI

71-8115-00-00

⑨ T joint

71-A246-60-00
71-A246-14-00

⑩ I joint

71-7629-60-00
71-7629-14-00

⑪ Suspension

installation kit
71-7676-00-00
Fixed bars
71-B502-60-00
71-B502-14-00

⑫ Decorative Caps

1m: **71-8030-60-00**
71-8030-14-00
2m: **71-8031-60-00**
71-8031-14-00
3m: **71-8032-60-00**
71-8032-14-00

Track Low Voltage

Surface & Pendant

BODY MAT
AL

Track Pendant & Surface

○ ●
14 60

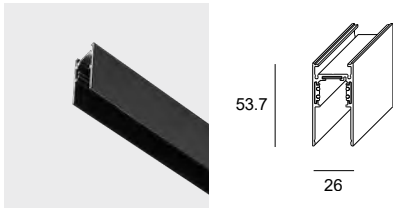









mm	Code
1000	71-7624
2000	71-7625 - 14 - 00
3000	71-7626 - 60 - 00

Power supplies

P. 985

Sources d'alimentation

	ON-OFF IP20, Remote 48V/75W	71-A258-00-00		ON-OFF IP67, Remote 48V/480W	71-B078-00-00
	ON-OFF IP20, Remote 48V/120W	71-A259-00-00		ON-OFF IP67, Remote 48V/620W	71-B079-00-00
	ON-OFF IP20, Remote 48V/160W	71-B658-00-00		ON-OFF IP20, Built-in 48V/100W	71-B440-60-00
	ON-OFF IP20, Remote 48V/250W	71-B659-00-00		ON-OFF IP20, Built-in 48V/250W	71-B441-60-00
	ON-OFF IP67, Remote 48V/320W	71-B077-00-00			

Connective controllers



P. 969

Contrôleurs connectés



Consult the available control systems / Consultez les systèmes de contrôle disponibles:
 DALI2 / DALI2
 Bluetooth wireless / Sans fil Bluetooth
 Autonomous / Autonome



Optional fixing accessories**Accessoires de fixation en option**

	Suspended ceiling rose with electrical outlet (2500mm) Patère suspendue avec prise de courant (2500mm)	ON-OFF	14	<input type="radio"/>	71-7520-14-00
			60	<input checked="" type="radio"/>	71-7520-60-00
		DALI	14	<input type="radio"/>	71-7521-14-00
			60	<input checked="" type="radio"/>	71-7521-60-00
	Remote power supply cable grommet Presse-étoupe pour source à distance		14	<input type="radio"/>	71-B245-14-00
			60	<input checked="" type="radio"/>	71-B245-60-00







Connection accessories**Accessoires de connexion**

	Power connector 48VDC Connecteur d'alimentation 48VDC		14	<input type="radio"/>	71-7637-14-00
			60	<input checked="" type="radio"/>	71-7637-60-00

Fixing accessories for pendant track**Accessoires de fixation pour rail suspendu**

	Cable installation kit (2000mm) Kit d'installation cables (2000mm)				71-7676-00-00
	Fixed bars 1000mm Barres fixes 1000mm		14	<input type="radio"/>	71-B502-14-00
			60	<input checked="" type="radio"/>	71-B502-60-00
	Fixed bar (1000 mm) extension kit Kit de rallonge à barre fixe 1 000 mm		14	<input type="radio"/>	71-B504-14-00
			60	<input checked="" type="radio"/>	71-B504-60-00

Joint accessories**Accessoires de raccord**

	"I" joint Pendant Raccord en « I » Pendant		14	<input type="radio"/>	71-7629-14-00
			60	<input checked="" type="radio"/>	71-7629-60-00
	"I" joint Surface Raccord en « I » Surface		14	<input type="radio"/>	71-7639-14-00
			60	<input checked="" type="radio"/>	71-7639-60-00
	Joint "T" Raccord en "T"		14	<input type="radio"/>	71-A246-14-00
			60	<input checked="" type="radio"/>	71-A246-60-00
	Joint "X" Raccord en "X"		14	<input type="radio"/>	71-A247-14-00
			60	<input checked="" type="radio"/>	71-A247-60-00
	Joint 90° L Horizontal Raccord en 90° L Horizontal		14	<input type="radio"/>	71-7627-14-00
			60	<input checked="" type="radio"/>	71-7627-60-00
	"L" internal vertical joint Raccord en « L » vertical intérieur		14	<input type="radio"/>	71-A244-14-00
			60	<input checked="" type="radio"/>	71-A244-60-00
	"L" external vertical joint Raccord en « L » vertical extérieur		14	<input type="radio"/>	71-A245-14-00
			60	<input checked="" type="radio"/>	71-A245-60-00

Decorative accessories**Accessoires décoratifs**

1000mm frontal embellished cap
Enjoliveur frontal 1 000 mm

14 ○

71-8030-14-00

60 ●

71-8030-60-00

2000mm frontal embellished cap
Enjoliveur frontal 2 000 mm

14 ○

71-8031-14-00

60 ●

71-8031-60-00

3000mm frontal embellished cap
Enjoliveur frontal 3 000 mm

14 ○

71-8032-14-00

60 ●

71-8032-60-00

Cable grommet cover + blank cover
Cache presse-étoupe + cache aveugle

00 ●

71-7705-00-00

14 ○

71-7705-14-00

Blank covers (2 u.)
Caches aveugles (2 u.)

00 ●

71-A334-00-00

14 ○

71-A334-14-00

Track Low Voltage Recessed

Installation diagram
Schéma d'installation

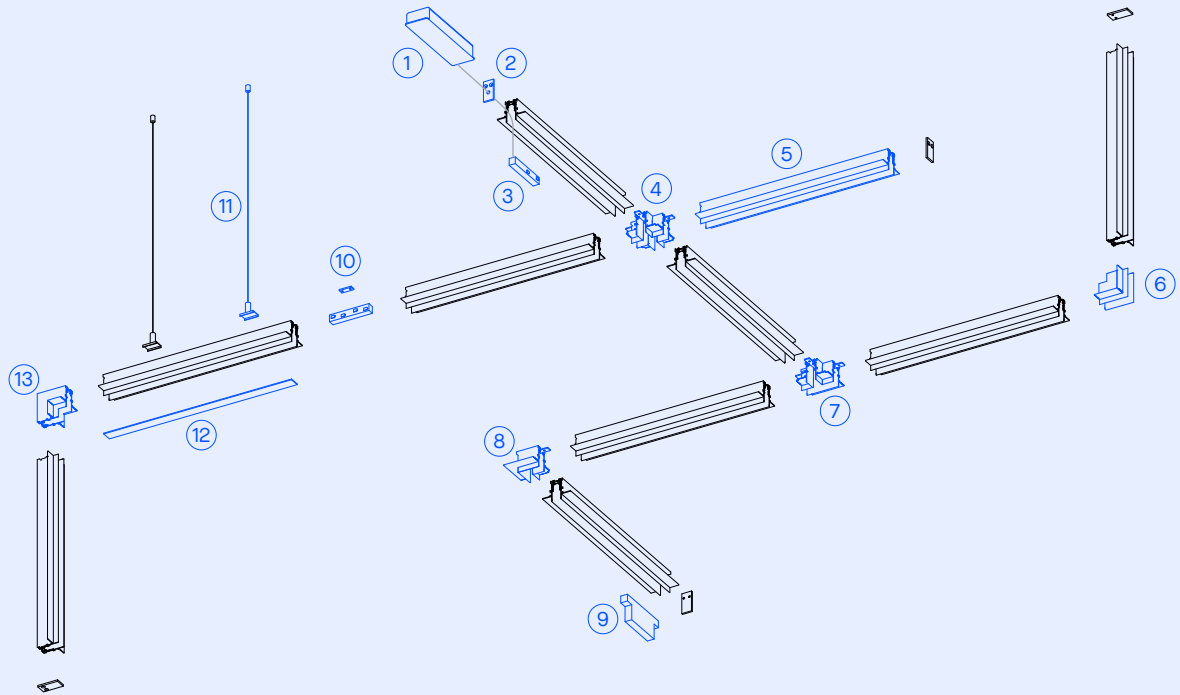

① Remote power source

71-A258-00-00
(48V / 75W)
71-A259-00-00
(48V / 120W)
71-B658-00-00
(160W IP20)
71-B659-00-00
(250W IP20)
71-B077-00-00
(48V / 320W)
71-B078-00-00
(48V / 480W)
71-B079-00-00
(48V / 620W)

Built-in power source

71-B440-60-00
(48V / 100W)
71-B441-60-00
(48V / 250W)

② End Cap with hole

71-7705-00-00
71-7705-14-00
End Cap without hole
71-A334-00-00
71-A334-14-00

③ Power connector

71-7637-60-00
71-7637-14-00

④ X joint

71-A251-60-00
71-A251-14-00

⑤ Track Low Voltage

1m: **71-7630-60-00**
71-7630-14-00
2m: **71-7631-60-00**
71-7631-14-00
3m: **71-7632-60-00**
71-7632-14-00

⑥ External L Vertical joint

71-A249-60-00
71-A249-14-00

⑦ T joint

71-A250-60-00
71-A250-14-00

⑧ Horizontal L joint

71-7706-60-00
71-7706-14-00

⑨ Converter Casambi DALI

71-8115-00-00

⑩ I joint

71-7633-60-00
71-7633-14-00

⑪ Suspension installation kit

71-7634-00-00

⑫ Decorative Caps

1m: **71-8030-60-00**
71-8030-14-00
2m: **71-8031-60-00**
71-8031-14-00
3m: **71-8032-60-00**
71-8032-14-00

⑬ Internal L Vertical joint

71-A248-60-00
71-A248-14-00

Track Low Voltage

Recessed

BODY MAT

AL

Track Low Voltage Recessed

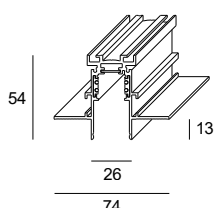
 14 60

mm
1000
2000
3000

Code









71-7630
71-7631 - 14 - 00
71-7632 - 60 - 00

54xL 3-13 mm

Power supplies

P. 985

Sources d'alimentation

	ON-OFF IP20, Remote 48V/75W	71-A258-00-00		ON-OFF IP67, Remote 48V/480W	71-B078-00-00
	ON-OFF IP20, Remote 48V/120W	71-A259-00-00		ON-OFF IP67, Remote 48V/620W	71-B079-00-00
	ON-OFF IP20, Remote 48V/160W	71-B658-00-00		ON-OFF IP20, Built-in 48V/100W	71-B440-60-00
	ON-OFF IP20, Remote 48V/250W	71-B659-00-00		ON-OFF IP20, Built-in 48V/250W	71-B441-60-00
	ON-OFF IP67, Remote 48V/320W	71-B077-00-00			

Connective controllers

P. 969

Contrôleurs connectés



Consult the available control systems / Consultez les systèmes de contrôle disponibles:

DALI2 / DALI2

Bluetooth wireless / Sans fil Bluetooth

Autonomous / Autonome

Fixing accessories

Accessoires de fixation



Installation kit (2000mm)
Kit d'installation (2000mm)

71-7634-00-00

Connection accessories

Accessoires de connexion









Power connector 48VDC
Connecteur d'alimentation 48VDC

14 **71-7637-14-00**60 **71-7637-60-00**



Accesorios de union

Accessoires de Raccord en

	"I" joint Raccord en « I »	14 ○	71-7633-14-00
		60 ●	71-7633-60-00
	"T" joint Raccord en « T »	14 ○	71-A250-14-00
		60 ●	71-A250-60-00
	"X" joint Raccord en « X »	14 ○	71-A251-14-00
		60 ●	71-A251-60-00
	Union "L" Horizontal Raccord en "L" Horizontal	14 ○	71-7706-14-00
		60 ●	71-7706-60-00
	"L" internal vertical joint Raccord en « L » vertical intérieur	14 ○	71-A248-14-00
		60 ●	71-A248-60-00
	"L" external vertical joint Raccord en « L » vertical extérieur	14 ○	71-A249-14-00
		60 ●	71-A249-60-00

Decorative accessories

Accessoires décoratifs

	1000mm frontal embellished cap Enjoliveur frontal 1 000 mm	14 ○	71-8030-14-00
		60 ●	71-8030-60-00
	2000mm frontal embellished cap Enjoliveur frontal 2 000 mm	14 ○	71-8031-14-00
		60 ●	71-8031-60-00
	3000mm frontal embellished cap Enjoliveur frontal 3 000 mm	14 ○	71-8032-14-00
		60 ●	71-8032-60-00
	Cable grommet cover + blank cover Cache presse-étoupe + cache aveugle	00 ●	71-7705-00-00
		14 ○	71-7705-14-00
	Blank covers (2 u.) Caches aveugles (2 u.)	00 ●	71-A334-00-00
		14 ○	71-A334-14-00

Track Low Voltage Up & Down

Installation diagram
Schéma d'installation

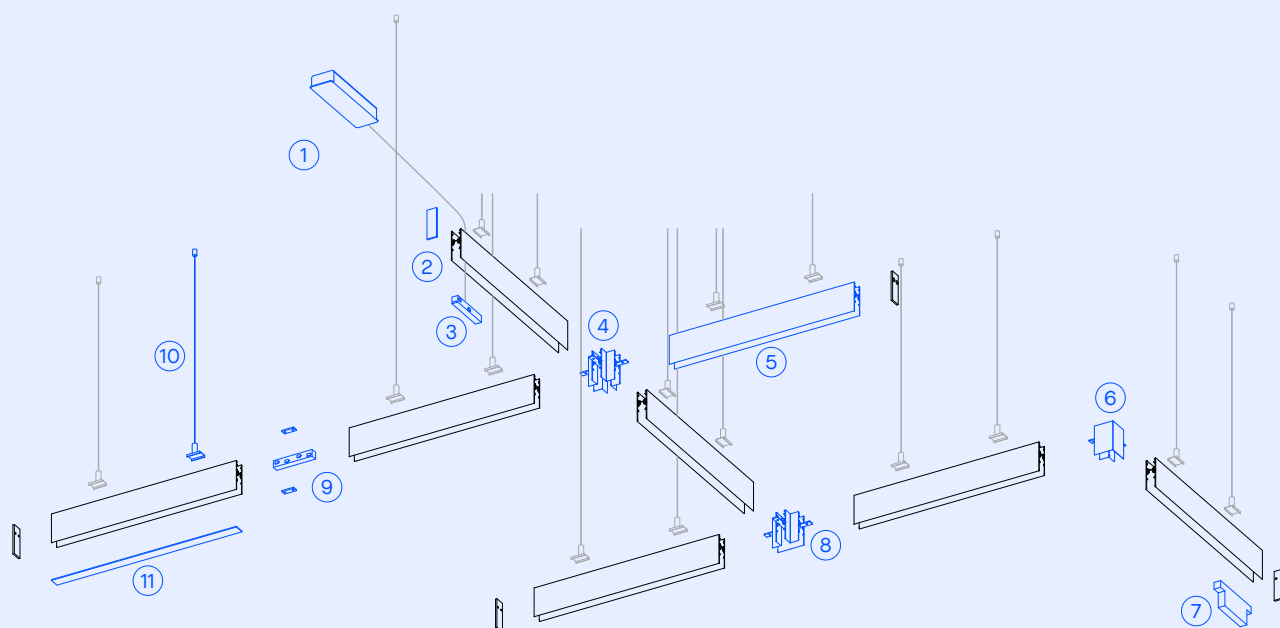

① Remote power source

71-A258-00-00
(48V / 75W)

71-A259-00-00
(48V / 120W)

71-B658-00-00
(160W IP20)

71-B659-00-00
(250W IP20)

71-B077-00-00
(48V / 320W)

71-B078-00-00
(48V / 480W)

71-B079-00-00
(48V / 620W)

Built-in power source

71-B440-60-00
(48V / 100W)

71-B441-60-00
(48V / 250W)

② Track End cap

71-8046-60-00

71-8046-14-00

③ Power connector

71-7637-60-00

71-7637-14-00

④ X joint

71-A253-60-00

71-A253-14-00

⑤ Track Low Voltage

1m: **71-8043-60-00**
71-8043-14-00

2m: **71-8044-60-00**
71-8044-14-00

3m: **71-8045-60-00**
71-8045-14-00

⑥ L joint

71-8047-60-00

71-8047-14-00

⑦ Converter Casambi DALI

71-8115-00-00

⑧ T joint

71-A252-60-00

71-A252-14-00

⑨ I joint

71-B785-60-00

71-B785-14-00

⑩ Suspension installation kit

71-8124-00-00

Fixed bars

71-B639-60-00

71-B639-14-00

⑪ Decorative Caps

1m: **71-8030-60-00**

71-8030-14-00

2m: **71-8031-60-00**

71-8031-14-00

3m: **71-8032-60-00**

71-8032-14-00

Track Low Voltage Up&Down

○ ●
14 60

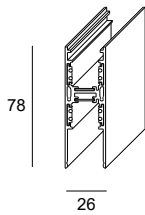
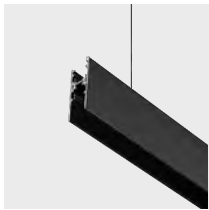

mm	Code
1000	71-8043
2000	71-8044 - 14 - 00
3000	71-8045 - 60 - 00

Power supplies

P. 985

Sources d'alimentation

	ON-OFF IP20, Remote 48V/75W	71-A258-00-00		ON-OFF IP67, Remote 48V/480W	71-B078-00-00
	ON-OFF IP20, Remote 48V/120W	71-A259-00-00		ON-OFF IP67, Remote 48V/620W	71-B079-00-00
	ON-OFF IP20, Remote 48V/160W	71-B658-00-00		ON-OFF IP20, Built-in 48V/100W	71-B440-60-00
	ON-OFF IP20, Remote 48V/250W	71-B659-00-00		ON-OFF IP20, Built-in 48V/250W	71-B441-60-00
	ON-OFF IP67, Remote 48V/320W	71-B077-00-00			

Connective controllers

P. 969

Contrôleurs connectés



Consult the available control systems / Consultez les systèmes de contrôle disponibles:

DALI2 / DALI2
Bluetooth wireless / Sans fil Bluetooth
Autonomous / Autonome

Fixing accessories

Accessoires de fixation

	Cuttable profile for installation on Up & Down track (L=3000 mm) Profilé découpable pour installation sur rail Up & Down (L=3000 mm)	71-B350-00-00
--	-----------------------------------------------------------------------------------------------------------------------------------------	----------------------

Optional fixing accessories

Accessoires de fixation en option

	Suspended ceiling rose with electrical outlet (2500mm) Patère suspendue avec prise de courant (2500mm)	ON-OFF	14 ○	71-7520-14-00
			60 ●	71-7520-60-00
		DALI	14 ○	71-7521-14-00
			60 ●	71-7521-60-00
	Remote power supply cable grommet Presse-étoupe pour source à distance		14 ○	71-B245-14-00
			60 ●	71-B245-60-00

Fixing accessories for pendant track

Accessoires de fixation pour rail suspendu

	Cable installation kit (2000mm) Kit d'installation câbles (2000mm)			71-8124-00-00
	Fixed bars Barres fixes	14	○	71-B639-14-00
		60	●	71-B639-60-00
	Fixed bar installation kit 1000mm Kit d'installation barres fixes 1000mm	14	○	71-B504-14-00
		60	●	71-B504-60-00

Connection accessories

Accessoires de connexion

	Power connector 48VDC Connecteur d'alimentation 48VDC	14	○	71-7637-14-00
		60	●	71-7637-60-00

Joint accessories

Accessoires de raccord

	"I" joint Raccord en « I »	14	○	71-B785-14-00
		60	●	71-B785-60-00
	Union "L" Horizontal Raccord en "L" Horizontal	14	○	71-8047-14-00
		60	●	71-8047-60-00
	"T" joint Raccord en « T »	14	○	71-A252-14-00
		60	●	71-A252-60-00
	"X" joint Raccord en « X »	14	○	71-A253-14-00
		60	●	71-A253-60-00

Decorative accessories

Accessoires décoratifs

	1000mm frontal embellished cap Enjoliveur frontal 1 000 mm	14	○	71-8030-14-00
		60	●	71-8030-60-00
	2000mm frontal embellished cap Enjoliveur frontal 2 000 mm	14	○	71-8031-14-00
		60	●	71-8031-60-00
	3000mm frontal embellished cap Enjoliveur frontal 3 000 mm	14	○	71-8032-14-00
		60	●	71-8032-60-00
	Blank covers (2 u.) Caches aveugles (2 u.)	14	○	71-8046-14-00
		60	●	71-8046-60-00

Track Hyperlink Surface

Installation diagram
Schéma d'installation

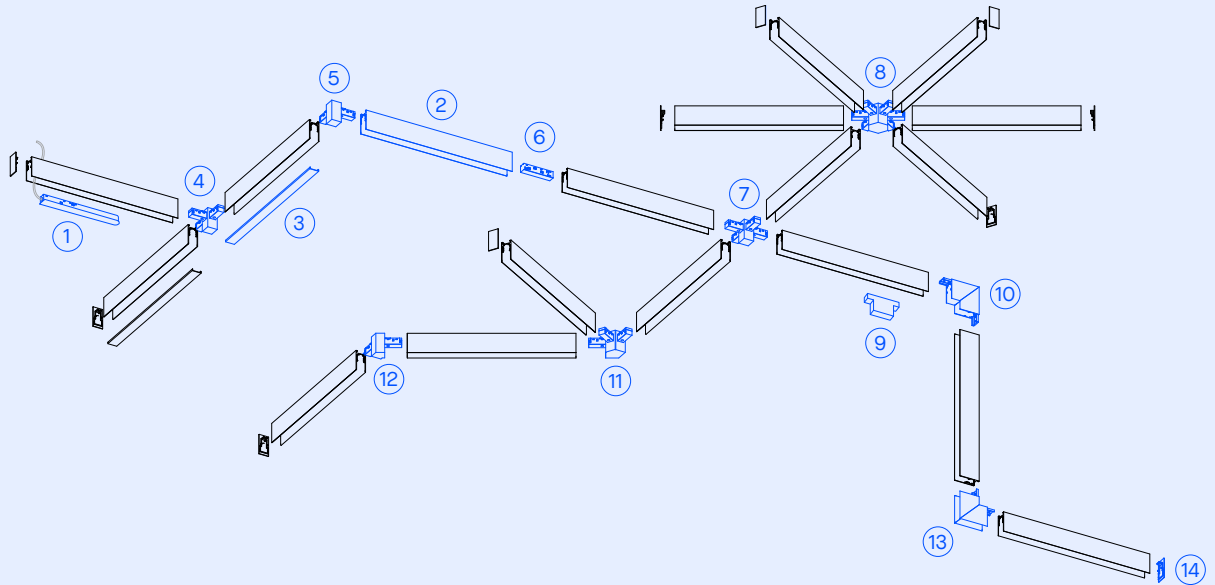

① **Built-in power source**
71-B440-60-00
(48V / 100W)
71-B441-60-00
(48V / 250W)

② **Track Low Voltage Hyperlink**
1m: 71-B591-60-00
2m: 71-B592-60-00
3m: 71-B593-60-00

③ **Decorative caps**
1m: 71-8030-60-00
2m: 71-8031-60-00
3m: 71-8032-60-00

④ **T joint**
71-B685-60-00

⑤ **L joint**
71-B613-60-00

⑥ **I joint surface**
71-B472-60-00

⑦ **X joint**
71-B686-60-00

⑧ **O 360° joint**
71-B689-60-00

⑨ **Converter Casambi DALI**
71-8115-00-00

⑩ **L vertical IN joint**
71-B683-60-00

⑪ **T 60° joint**
71-B688-60-00

⑫ **L 120° joint**
71-B687-60-00

⑬ **L Vertical OUT joint**
71-B684-60-00

⑭ **End Cap with hole**
71-B476-60-00
End Cap without hole
71-B477-60-00

Track Hyperlink Surface

IP
20



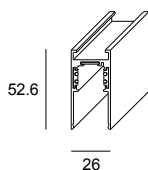





●
60



mm	Code
1000	71-B591
2000	71-B592 - 60 - 00
3000	71-B593

Power supplies Sources d'alimentation

P. 985

	ON-OFF IP20, Remote 48V/75W	71-A258-00-00		ON-OFF IP67, Remote 48V/480W	71-B078-00-00
	ON-OFF IP20, Remote 48V/120W	71-A259-00-00		ON-OFF IP67, Remote 48V/620W	71-B079-00-00
	ON-OFF IP20, Remote 48V/160W	71-B658-00-00		ON-OFF IP20, Built-in 48V/100W	71-B440-60-00
	ON-OFF IP20, Remote 48V/250W	71-B659-00-00		ON-OFF IP20, Built-in 48V/250W	71-B441-60-00
	ON-OFF IP67, Remote 48V/320W	71-B077-00-00			

Connective controllers Contrôleurs connectés



P. 969



Consult the available control systems / Consultez les systèmes de contrôle disponibles:

DALI2 / DALI2
Bluetooth wireless / Sans fil Bluetooth
Autonomous / Autonome

Required fixing accessories Accessoires de fixation nécessaires

	Suspended ceiling rose with electrical outlet (2500mm) Patère suspendue avec prise de courant (2500mm)	ON-OFF	60 ●	71-7520-60-00
		DALI	60 ●	71-7521-60-00
	Remote power supply cable grommet Presse-étoupe pour source à distance		14 ○	71-B245-14-00
			60 ●	71-B245-60-00

Connection accessories Accessoires de connexion



Power connector 48VDC
Connecteur d'alimentation 48VDC

71-B475-60-00

Joint accessories**Accessoires de raccord**

	"I" joint Raccord en "I"	71-B472-60-00
	"L" horizontal joint Raccord en "L" horizontal	71-B613-60-00
	"O" joint 360° Raccord en "O" 360°	71-B689-60-00
	"T" joint Raccord en "T"	71-B685-60-00
	"L" joint 120° Raccord en "L" 120°	71-B687-60-00
	"L" internal vertical joint Raccord en "L" vertical interior	71-B683-60-00
	"L" external vertical joint Raccord en "L" vertical exterior	71-B684-60-00
	"X" joint Raccord en "X"	71-B686-60-00
	"T" joint 60° Raccord en "T" 60°	71-B688-60-00

Decorative accessories**Accessoires décoratifs**

	1000mm frontal embellished cap Enjoliveur frontal 1 000 mm	71-8030-60-00
	2000mm frontal embellished cap Enjoliveur frontal 2 000 mm	71-8031-60-00
	3000mm frontal embellished cap Enjoliveur frontal 3 000 mm	71-8032-60-00
	Blank covers (2 u.) Caches aveugles (2 u.)	71-B477-60-00
	Cable grommet cover + blank cover Cache presse-étoupe + cache aveugle	71-B476-60-00

Track Hyperlink Recessed

Installation diagram
Schéma d'installation

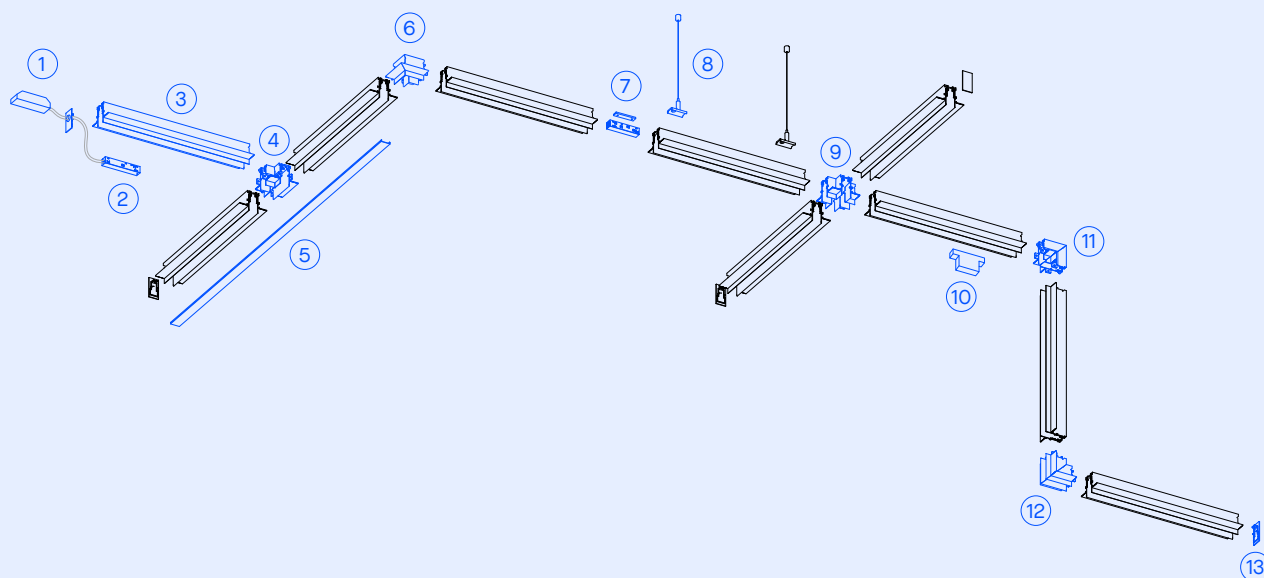

- ① **Remote power source**
71-A258-00-00
 (48V / 75W)
71-A259-00-00
 (48V / 120W)
71-7646-00-00
 (48V / 150W)
71-7647-00-00
 (48V / 240W)
71-7648-00-00
 (DIN 48V / 240W)
71-B077-00-00
 (48V / 320W)
71-B078-00-00
 (48V / 480W)
71-B079-00-00
 (48V / 620W)

- ② **Power connector**
71-B475-60-00
- ③ **Track Low Voltage Hyperlink**
 1m: **71-B594-60-00**
 2m: **71-B595-60-00**
 3m: **71-B596-60-00**
- ④ **T joint**
71-B692-60-00
- ⑤ **Decorative caps**
 1m: **71-8030-60-00**
 2m: **71-8031-60-00**
 3m: **71-8032-60-00**

- ⑥ **L Horizontal**
71-B471-60-00
- ⑦ **I joint**
71-B474-60-00
- ⑧ **Suspension installation kit**
71-7634-00-00
- ⑨ **X joint**
71-B693-60-00
- ⑩ **Converter Casambi DALI**
71-8115-00-00

- ⑪ **L vertical IN joint**
71-B690-60-00
- ⑫ **L vertical OUT**
71-B691-60-00
- ⑬ **End cap without hole**
71-B477-60-00
End cap with hole
71-B476-60-00

**Track Hyperlink
Recessed**

IP
20

LV

INDOOR

●
60

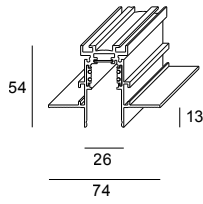

mm	Code
1000	71-B594
2000	71-B595 - 60 - 00
3000	71-B596

54xL 3-13 mm

LOW VOLTAGE | BASSE TENSION

Power supplies
Sources d'alimentation

P. 985

	ON-OFF IP20, Remote 48V/75W	71-A258-00-00		ON-OFF IP67, Remote 48V/480W	71-B078-00-00
	ON-OFF IP20, Remote 48V/120W	71-A259-00-00		ON-OFF IP67, Remote 48V/620W	71-B079-00-00
	ON-OFF IP20, Remote 48V/160W	71-B658-00-00		ON-OFF IP20, Built-in 48V/100W	71-B440-60-00
	ON-OFF IP20, Remote 48V/250W	71-B659-00-00		ON-OFF IP20, Built-in 48V/250W	71-B441-60-00
	ON-OFF IP67, Remote 48V/320W	71-B077-00-00			

Connective controllers
Contrôleurs connectés

P. 969



Consult the available control systems / Consultez les systèmes de contrôle disponibles:
DALI2 / DALI2
Bluetooth wireless / Sans fil Bluetooth
Autonomous / Autonome

Fixing accessories**Accessoires de fixation**

Installation kit (2000mm)
Kit d'installation (2000mm)

71-7634-00-00**Connection accessories****Accessoires de connexion**

Power connector 48VDC
Connecteur d'alimentation 48VDC

71-B475-60-00**Joint accessories****Accessoires de raccord**

"L" horizontal joint
Raccord en "L" horizontal

71-B471-60-00

"T" joint
Raccord en "T"

71-B474-60-00

"X" joint
Raccord en "X"

71-B693-60-00

"L" internal vertical joint
Raccord en "L" vertical interior

71-B690-60-00

"L" external vertical joint
Raccord en "L" vertical exterior

71-B691-60-00

"T" joint
Raccord en "T"

71-B692-60-00**Decorative accessories****Accessoires décoratifs**

Blank covers (2 u.)
Caches aveugles (2 u.)

71-B476-60-00

Cable grommet cover + blank cover
Cache presse-étoupe + cache aveugle

71-B477-60-00

1000mm frontal embellished cap
Enjoliveur frontal 1 000 mm

71-8030-60-00

2000mm frontal embellished cap
Enjoliveur frontal 2 000 mm

71-8031-60-00

3000mm frontal embellished cap
Enjoliveur frontal 3 000 mm

71-8032-60-00

Track Hyperlink Pendant

Installation diagram
Schéma d'installation

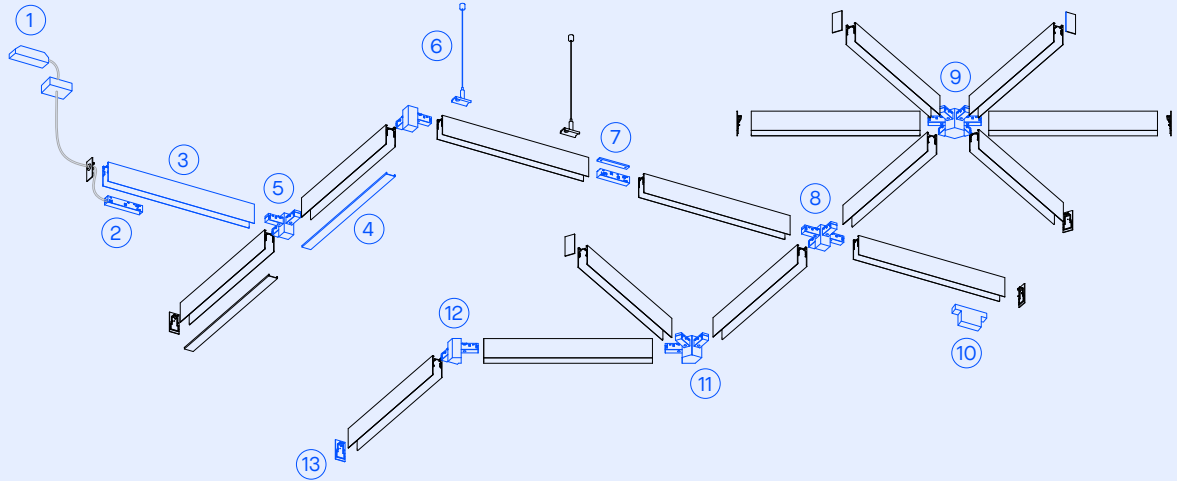

- ① **Remote power source**
71-A258-00-00
(48V / 75W)
71-A259-00-00
(48V / 120W)
71-7646-00-00
(48V / 150W)
71-7647-00-00
(48V / 240W)
71-7648-00-00
(DIN 48V / 240W)
71-B077-00-00
(48V / 320W)
71-B078-00-00
(48V / 480W)
71-B079-00-00
(48V / 620W)

- ② **Power connector**
71-B475-60-00
- ③ **Track Low Voltage Hyperlink**
1m: 71-B591-60-00
2m: 71-B592-60-00
3m: 71-B593-60-00
- ④ **Decorative caps**
1m: 71-8030-60-00
2m: 71-8031-60-00
3m: 71-8032-60-00

- ⑤ **T joint**
71-B685-60-00
- ⑥ **Suspension installation kit**
71-7676-00-00
Fixed Bars
71-B502-60-00
- ⑦ **I joint**
71-B473-60-00
- ⑧ **X joint**
71-B686-60-00
- ⑨ **O 360° joint**
71-B689-60-00

- ⑩ **Converter**
Casambi DALI
71-8115-00-00
- ⑪ **T 60° joint**
71-B688-60-00
- ⑫ **L 120° joint**
71-B687-60-00
- ⑬ **End Cap with hole**
71-B476-60-00
End Cap without hole
71-B477-60-00

Track Hyperlink Pendant

IP
20

●
60

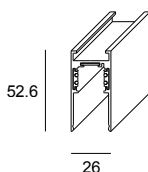









mm	Code
1000	71-B591
2000	71-B592 - 60 - 00
3000	71-B593

Power supplies

P. 985

Sources d'alimentation

	ON-OFF IP20, Remote 48V/75W	71-A258-00-00		ON-OFF IP67, Remote 48V/480W	71-B078-00-00
	ON-OFF IP20, Remote 48V/120W	71-A259-00-00		ON-OFF IP67, Remote 48V/620W	71-B079-00-00
	ON-OFF IP20, Remote 48V/160W	71-B658-00-00		ON-OFF IP20, Built-in 48V/100W	71-B440-60-00
	ON-OFF IP20, Remote 48V/250W	71-B659-00-00		ON-OFF IP20, Built-in 48V/250W	71-B441-60-00
	ON-OFF IP67, Remote 48V/320W	71-B077-00-00			

Connective controllers

P. 969

Contrôleurs connectés



Consult the available control systems / Consultez les systèmes de contrôle disponibles:





DALI2 / DALI2

Bluetooth wireless / Sans fil Bluetooth

Autonomous / Autonome

Fixing accessories

Accessoires de fixation

	Suspended ceiling rose with electrical outlet (2500mm) Patère suspendue avec prise de courant (2500mm)	ON-OFF	60 ●	71-7520-60-00
		DALI	60 ●	71-7521-60-00
	Remote power supply cable grommet Presse-étoupe pour source à distance		14 ○	71-B245-14-00
			60 ●	71-B245-60-00
	Installation kit (2000mm) Kit d'installation (2000mm)			71-7676-00-00
	Fixed bars 1000mm (2u.) Barres fixes 1000mm (2u.)		14 ○	71-B502-14-00
			60 ●	71-B502-60-00
	Fixed bar installation kit 1000mm (2u.) Kit de rallonge à barre fixe 1 000 mm (2u.)		14 ○	71-B504-14-00
			60 ●	71-B504-60-00

Connection accessories

Accessoires de connexion



Power connector 48VDC
Connecteur d'alimentation 48VDC

71-B475-60-00

Joint accessories

Accessoires de raccord



"I" joint
Raccord en « I »

71-B473-60-00



"L" joint
Raccord en « L »

71-B613-60-00



"O" joint 360°
Raccord en « O » 360°

71-B689-60-00



"X" joint
Raccord en « X »

71-B686-60-00



"L" joint 120°
Raccord en « L » 120°

71-B687-60-00



"T" joint
Raccord en « T »

71-B685-60-00



"T" joint 60°
Raccord en « T » 60°

71-B688-60-00

Decorative accessories

Accessoires décoratifs



Blank covers (2 u.)
Caches aveugles (2 u.)

71-B477-60-00



Cable grommet cover + blank cover
Cache presse-étoupe + cache aveugle

71-B476-60-00



1000mm frontal embellished cap
Enjoliveur frontal 1 000 mm

71-8030-60-00

2000mm frontal embellished cap
Enjoliveur frontal 2 000 mm

71-8031-60-00

3000mm frontal embellished cap
Enjoliveur frontal 3 000 mm

71-8032-60-00

Downlights

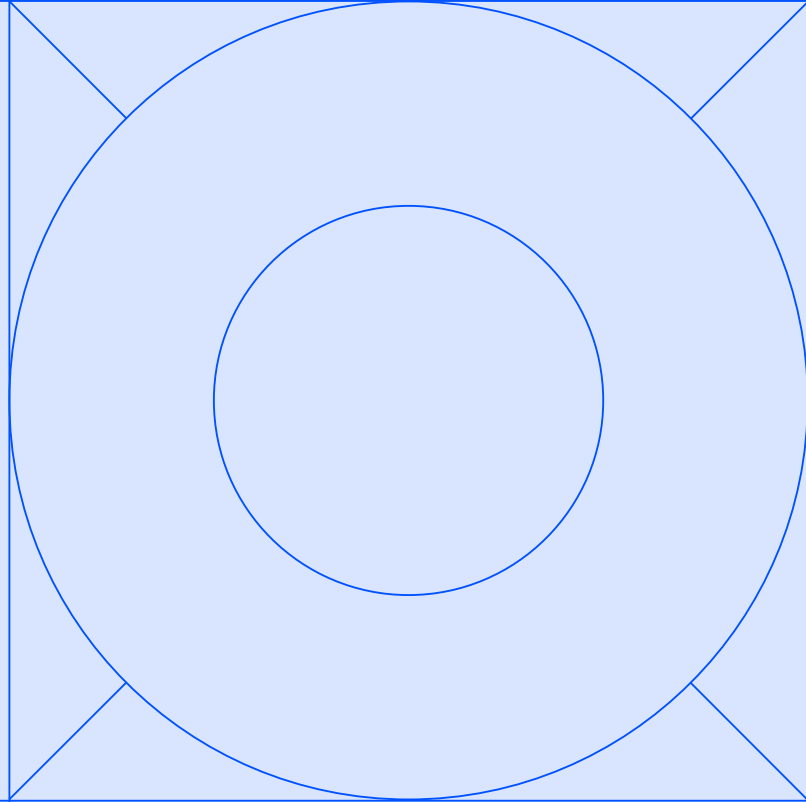

Nit

174



Veo

178

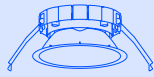

Vol

182



Play

184

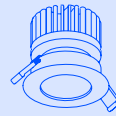

Lite

220

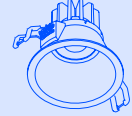

Dome

229



Ges

230

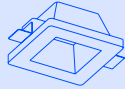

Bento

232

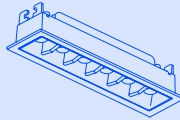

Multidir Evo

247

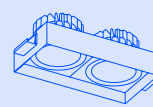

Totem

250

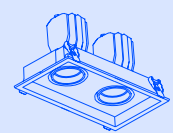

Ecofit

255

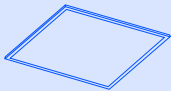

Nit

Designed by LedsC4 Architectural



+ Nit



Maximum performance and comfort Maximum de rendement et de confort

Nit is a meticulously designed downlight offering exceptional performance and an unparalleled lighting experience. Its ability to uniformly illuminate spaces ensures a natural and controlled distribution of light. With varying sizes and output angles, Nit seamlessly adapts to a wide range of architectures, from spaces with high ceilings to more compact areas, providing both general and directional lighting with adjustable options.

Nit est un downlight méticuleusement conçu pour offrir des performances exceptionnelles et une expérience d'éclairage sans égale. Sa capacité à éclairer uniformément les espaces garantit une distribution naturelle et contrôlée de la lumière. Avec ses différentes tailles et angles de sortie, Nit s'adapte parfaitement à un large éventail d'architectures, des espaces à hauts plafonds aux espaces plus compacts, offrant à la fois un éclairage général et directionnel avec des options réglables.



Fixed
Fixe



Adjustable
Ajustable

Fixed and adjustable versions Versions fixes et réglables

Fixed versions offer greater visual comfort by preventing glare. The adjustable ones allow both accent and general lighting, enabling the focusing of the light.

Les versions fixes offrent un meilleur confort visuel en évitant l'éblouissement. Les versions orientables permettent un éclairage d'accentuation et un éclairage général, ainsi que l'orientation de la lumière.



Adjustable lens Optique réglable

Bidirectional rotation system to focus the light in any direction without moving the luminaire.

Système de rotation bidirectionnelle permettant de diriger la lumière dans n'importe quelle direction sans avoir à déplacer le luminaire.

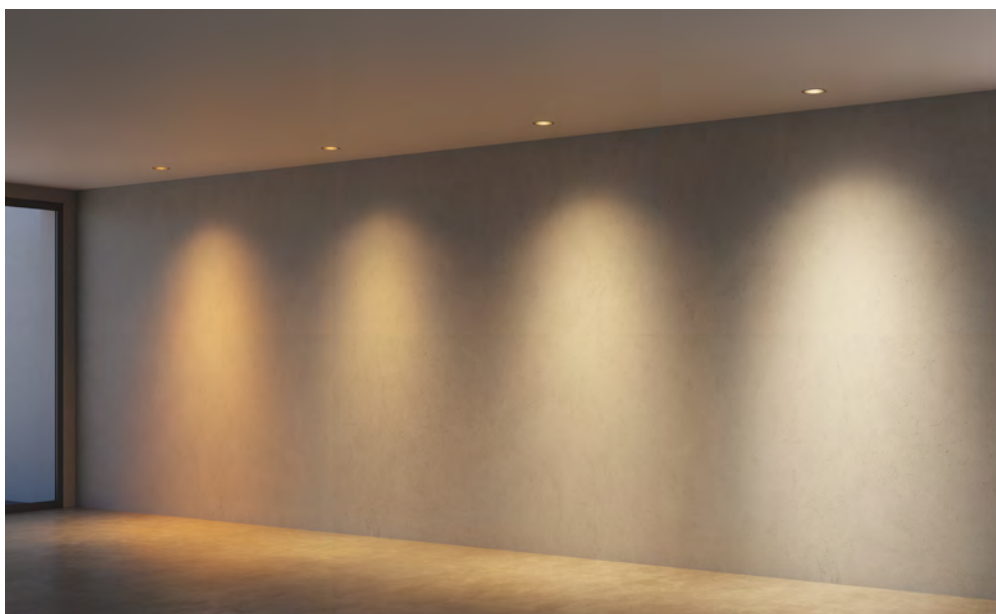

Four color temperatures available (2700K, 3000K, 3500K, 4000K)

Quatre températures de color disponibles (2700K, 3000K, 3500K, 4000K)

Unique design that allows optimal heat dissipation in a compact piece
Design unique qui permet une dissipation optimale de la chaleur dans un boîtier compact



Nit Small



Code example / Exemple d'élaboration d'une référence: **AG13-P7V9S10U14**

Model		W	K	CRI	Optics	Lm	Source	Finishes
	BH11 - Round Fixed	11V9	11.8	2700	90	M1 22° 1394-1473	OS ON-OFF 220-240V	60 14
		11W9	11.8	3000	90	M3 37° 1485-1569	DS DALI-2 220-240V	
	0-35 mm	11D9	11.8	3500	90	F2 56° 1431-1512	BB 36V/max.350mA	
	Ø 98	11X9	11.8	4000	90			
	BH13 - Round Adjustable	16V9	16.4	2700	90	M1 26° 1985-2095	OS ON-OFF 220-240V	
		16W9	16.4	3000	90	M3 38° 2118-2235	DS DALI-2 220-240V	
	0-35 mm	16D9	16.4	3500	90	F2 58° 2036-2148	BB 36V/max.500mA	
	Ø 108	16X9	16.4	4000	90			
	20°	27V9	27.2	2700	90	M1 25° 2902-3061	OS ON-OFF 220-240V	
	355°	27W9	27.2	3000	90	M3 38° 3090-3260	DS DALI-2 220-240V	
		27D9	27.2	3500	90	F2 57° 3000-3164	BB 36V/max.800mA	
		27X9	27.2	4000	90			

Code example / Exemple d'élaboration d'une référence: **BH12-27V9M10S60**

Nit Big



Model		W	K	CRI	Optics	Lm	Source	Finishes
	BH12 - Round Fixed	27V9	27.2	2700	90	M1 25° 3282-3462	OS ON-OFF 220-240V	60 14
		27W9	27.2	3000	90	M3 37° 3102-3272	DS DALI-2 220-240V	
	0-35 mm	27D9	27.2	3500	90	F2 60° 3038-3205	BB 36V/max.800mA	
	Ø 140	27X9	27.2	4000	90			
	BH14 - Round Adjustable	36V9	36.6	2700	90	M1 25° 4061-4283	OS ON-OFF 220-240V	
		36W9	36.6	3000	90	M3 37° 3890-4044	DS DALI-2 220-240V	
	0-35 mm	36D9	36.6	3500	90	F2 60° 3777-3984	BB 36V/max.1050mA	
	Ø 160	36X9	36.6	4000	90			
	20°	41V9	41.4	2700	90	M1 25° 4614-4879	OS ON-OFF 220-240V	
	355°	41W9	41.4	3000	90	M3 37° 4429-4684	DS DALI-2 220-240V	
		41D9	41.4	3500	90	F2 60° 4298-4545	BB 36V/max.1200mA	
		41X9	41.4	4000	90			

Nit Small

Nit Big

Lens accessories

Accessoires optiques



Honeycomb panel (5u.)
Grille en nid d'abeille (5 u.)

71-A177-60-00

71-A855-60-00



An effective solution for any kind of setting Solution efficace dans toutes sortes de décor

This is a basic downlight featuring a clean, functional design for multi-purpose spaces. It adapts to different recessing diameters, thereby facilitating installation on ceilings where there is already a gap.

Avec son design épuré et fonctionnel, ce downlight d'entrée de gamme destiné à des espaces variés s'adapte à différents diamètres d'encastrement, ce qui facilite son installation dans des plafonds dotés d'un orifice préalable.

Different sizes Différentes tailles



Small



Medium



Big



Includes an extra bezel that allows it to be installed in recessing gaps with a size different to standard sizing
 Bague supplémentaire qui permet de l'installer dans des orifices d'encastrement de dimensions non standard

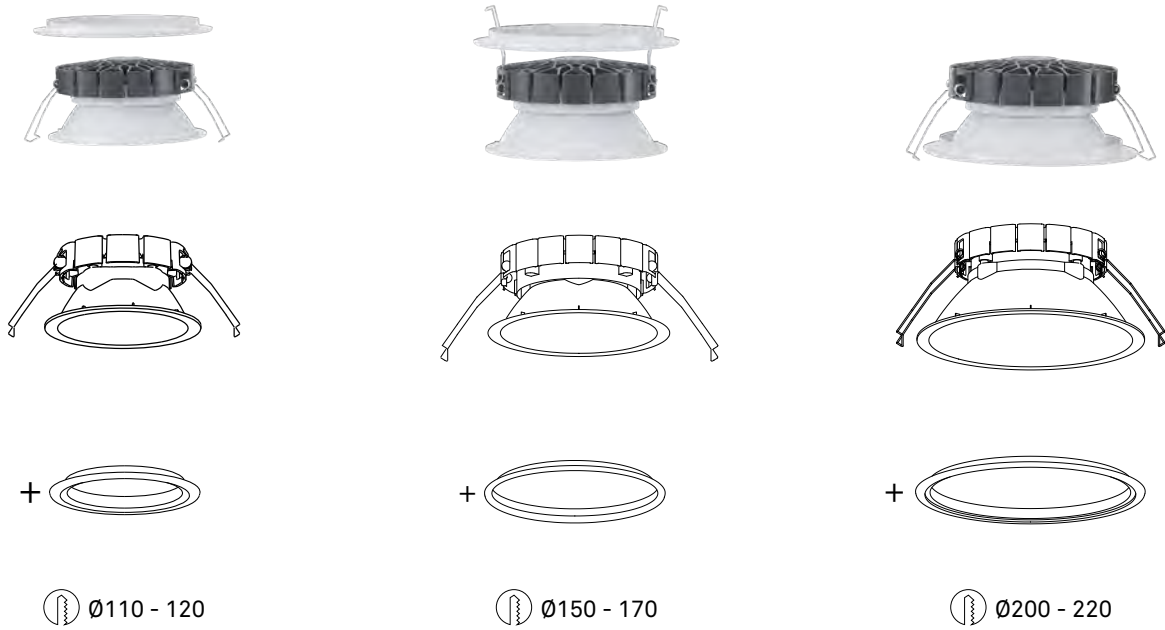

Ø 110-130



Ø 161-180



Ø 210-230

Smaller installed size
Dimension d'installation réduite

Its design allows heat to effectively dissipate, even though the piece is fairly shallow
 Design qui permet de dissiper la chaleur en toute efficacité même si la pièce est de faible hauteur

Easy maintenance thanks to a special anti-scratch and anti-dust treatment
 Entretien facile grâce à un traitement spécial anti-rayures et anti-poussière



Veo Ø130

BODY MAT	DIF MAT		50000h	3	IP	LOW			
PC,AL	PC		L80 B20	MacAdam	54	FLICKER			

14



62



100 0-25 mm

LED									
K	CRI	W Total	Real Lm	Optics	Code				
3000	82	10	1123	67°	90-A032 - 14	OO	ON-OFF 220-240V		
						DS	DALI-2 220-240V		
4000	82	10	1156	67°	90-A033 - 14	OO	ON-OFF 220-240V		
						DS	DALI-2 220-240V		

Vevo Emergency
 P. 965

INDOOR

DOWNLIGHTS

Vevo Ø180

BODY MAT	DIF MAT		50000h	3	IP	LOW			
PC,AL	PC		L80 B20	MacAdam	54	FLICKER			

14



80

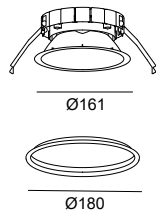

150-170 0-25 mm

LED									
K	CRI	W Total	Real Lm	Optics	Code				
3000	82	13.5	1434	66°	90-A034 - 14	OO	ON-OFF 220-240V		
						DS	DALI-2 220-240V		
4000	82	13.5	1477	66°	90-A035 - 14	OO	ON-OFF 220-240V		
						DS	DALI-2 220-240V		

Vevo Emergency
 P. 965

Vevo Ø230

BODY MAT	DIF MAT		50000h	3	IP	LOW			
PC,AL	PC		L80 B20	MacAdam	54	UGR <19	FLICKER		

14



100

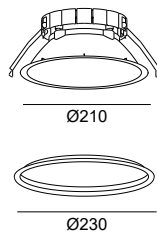

200-220 0-25 mm

LED									
K	CRI	W Total	Real Lm	Optics	Code				
3000	82	19.1	1960	74°	90-A036 - 14	OO	ON-OFF 220-240V		
						DS	DALI-2 220-240V		
4000	82	19.1	2019	74°	90-A037 - 14	OO	ON-OFF 220-240V		
						DS	DALI-2 220-240V		

Vevo Emergency
 P. 965

Connective controllers Contrôleurs connectés

P. 969



Consult the available control systems / Consultez les systèmes de contrôle disponibles:

DALI2 / DALI2

Bluetooth wireless / Sans fil Bluetooth

Autonomous / Autonome



This is a compact downlight that provides general and even lighting
 Downlight de taille compacte qui assure un éclairage général uniforme

Vol Ø135

BODY MAT	DIF MAT	3	IP	IK		50000h			
AL	PMMA	MacAdam	54	08		L80 B20			

14

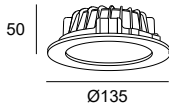

LED						
K	CRI	W Total	Real Lm	Code		
3000	80	10.7	847	90-4880 - 14 - M3	ON-OFF 100-240V	
4000	80	10.7	888	90-4881 - 14 - M3	ON-OFF 100-240V	

117 0-25 mm

Vol Emergency
 P. 963

Vol Ø135
Driver not Included

BODY MAT	DIF MAT	3	IP	IK		50000h			
AL	PMMA	MacAdam	54	08		L80 B20			

14

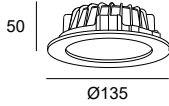

LED					max.700mA 12V	
K	CRI	W	Real Lm	Code		
3000	80	8.4	847	90-3925 - 14 - M3		
4000	80	8.4	888	90-3926 - 14 - M3		

117 0-25 mm

Vol Ø205

BODY MAT	DIF MAT	3	IP	IK		50000h			
AL	PMMA	MacAdam	54	08		L80 B20			

14

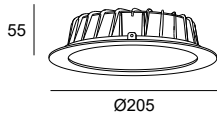

LED						
K	CRI	W Total	Real Lm	Code		
3000	80	18.1	1934	90-2899 - 14 - M3	ON-OFF 100-240V	
4000	80	18.1	1989	90-4883 - 14 - M3	ON-OFF 100-240V	

180 0-25 mm

Vol Emergency
 P. 963

Vol Ø205
Driver Not Included

BODY MAT	DIF MAT	3	IP	IK	50000h L80 B20		
AL	PMMA	MacAdam	54	08			

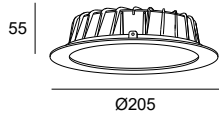
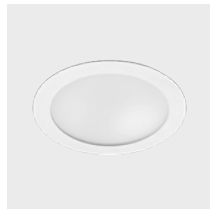

LED						max.700mA 24V	
K	CRI	W	Real Lm	Code			
3000	80	16.8	1934	90-3927 - 14 - M3			
4000	80	16.8	1989	90-3928 - 14 - M3			

180 0-25 mm

Vol Ø254

BODY MAT	DIF MAT	3	IP	IK	50000h L80 B20		
AL	PMMA	MacAdam	54	08			

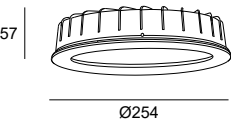

LED							
K	CRI	W Total	Real Lm	Code			
3000	80	28.4	3012	90-4885 - 14 - M3	ON-OFF 100-240V		
4000	80	28.4	3109	90-4886 - 14 - M3	ON-OFF 100-240V		

230 0-25 mm

Vol Emergency
 P. 963

Vol Ø254
Driver Not Included

BODY MAT	DIF MAT	3	IP	IK	50000h L80 B20		
AL	PMMA	MacAdam	54	08			

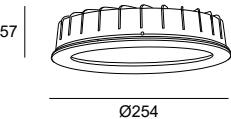

LED						max.700mA 36V	
K	CRI	W	Real Lm	Code			
3000	80	25.4	3012	90-3929 - 14 - M3			
4000	80	25.4	3109	90-3930 - 14 - M3			

230 0-25 mm

Vol Ø135

Vol Ø205

Vol Ø254

Drivers
Drivers

P. 984



ON-OFF
IP20

71-B232-00-00

71-6658-00-00

71-6653-00-00



PHASE CUT 240V
IP20

71-7663-00-00

71-A299-00-00

71-A299-00-00



DALI2 PUSH
IP20

71-A190-00-00

71-A192-00-00

71-A192-00-00



CASAMBI
IP20

71-A261-00-00

71-A261-00-00

71-A260-00-00

Play

Designed by LedsC4 Architectural



Track
P. 096



Pendant
P. 271



Ceiling
P. 283



Spotlight
P. 283



INDOOR



This collection of downlights offers endless possibilities and exceptional versatility, allowing it to easily adapt to any type of space. Its flexibility is such that you can create more than 40,000 configurations

Collection de downlights aux possibilités infinies et à la polyvalence exceptionnelle qui lui permet de s'adapter facilement à tout type d'espace. Offre une capacité de configuration de plus de 40 000 options

DOWNLIGHTS



Play Raw concrete AG59-P7W9M20UDC





INDOOR

DOWNLIGHTS



Play Visual Confort in a private residence project in Barcelona. Photography: Rafael Vargas
Play Visual Confort dans un projet de résidence privée à Barcelone. Photographie : Rafael Vargas



INDOOR

DOWNLIGHTS

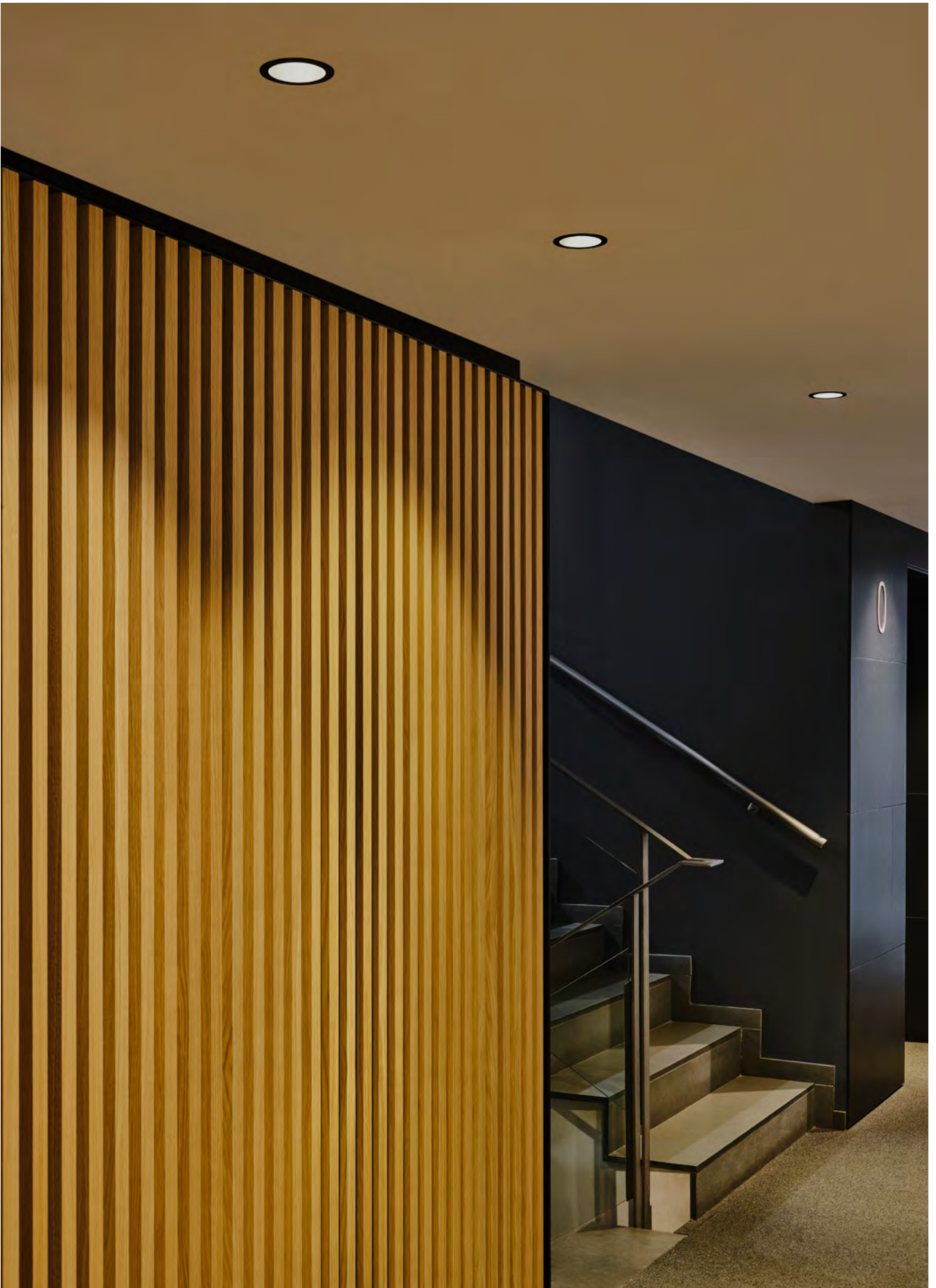

Play Deco Symmetrical in the Hotel Mon Sant Benet project. Photography: Marta Vidal.
Play Deco Symmetrical dans le cadre du projet de l'hôtel Mon Sant Benet. Photographie : Marta Vidal.



New 8° optics
Nouvelle optique à 8°



① Different modules based on size and need:
Différents modules en fonction de la taille et des besoins:

Play Mini:
1,5W
3W

Play Standard:
7W
13W
18W
Tunable White 13W

② Different lens options with different apertures:
Possibilité de différentes lentilles à ouvertures diverses:

Spot (6°-20°)
Medium (20°-40°)
Flood (40°-50°)

③ Wide variety of trims available, combinable with the different modules:

Grand nombre de collerettes disponibles, combinées avec les différents modules:

- Flat
- Deep
- High visual Comfort
- IP65
- IP65 Glass
- Pinhole
- Soft
- Snoot
- Raw Racy Gold
- Raw Walnut
- Raw Oak
- Raw Alabastre
- Raw Concrete
- Deco Symmetrical
- Deco Asymmetrical
- Deco Double
- Deco Surface

Accesorios opcionales:
Acessórios opcionais:

- 1 Honeycomb panel
Grille en nid d'abeille
- 2 Elliptical diffuser
Diffuseur elliptique
- 3 Square diffuser
Diffuseur carré
- 4 Opal diffuser
Diffuseur opalin
- 5 Screen
- 6 Visual Comfort

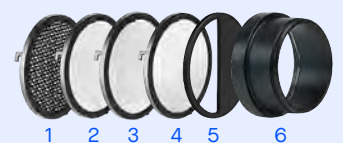

Tunable White

Play offers Tunable White versions that allow you to regulate the colour temperature on an ad-hoc basis via a control system or time schedule to simulate natural light, thus assisting in the human circadian rhythm.

Play propose des versions Tunable White qui permettent, grâce à un système de contrôle, de régler la température de couleur de manière ponctuelle ou via une programmation horaire, afin de simuler la lumière naturelle et d'aider ainsi le cycle circadien des personnes.

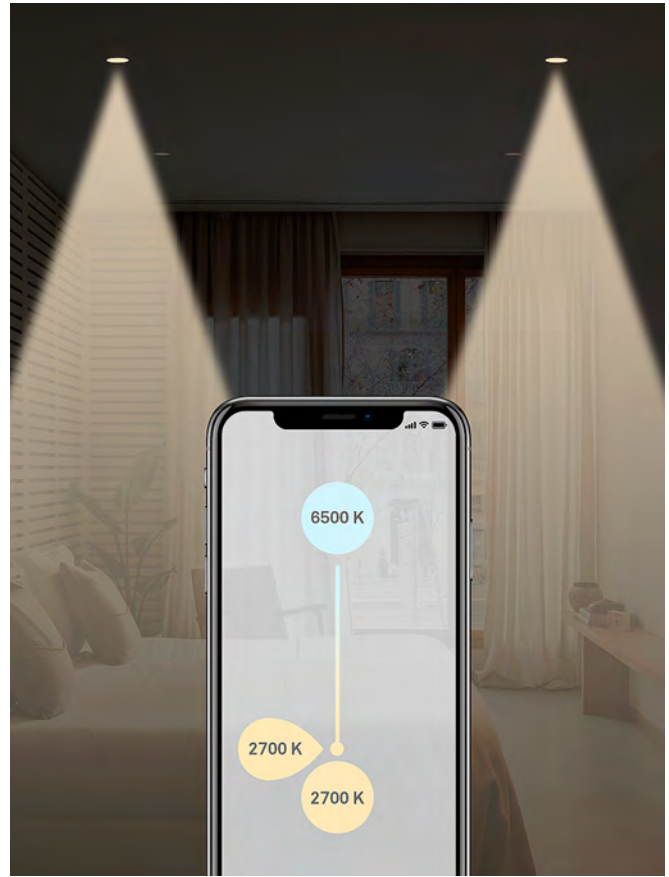

Smart Options Options Smart

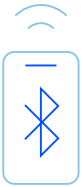

Thanks to its smart features, the Play luminaries can be configured to create different light atmospheres and offer additional flexibility, allowing users to save energy by monitoring occupancy or natural light entry, manage the space or carry out preventive maintenance, among other uses.

Grâce aux fonctionnalités Smart, on peut configurer Play de manière à créer des ambiances lumineuses qui dotent l'espace de flexibilité, afin d'économiser de l'énergie en contrôlant l'occupation ou l'apport de lumière naturelle, de gérer l'espace ou encore d'effectuer un entretien préventif, entre autres.



Hourly programming feature.
Fonction de programmation horaire.





INDOOR

DOWNLIGHTS

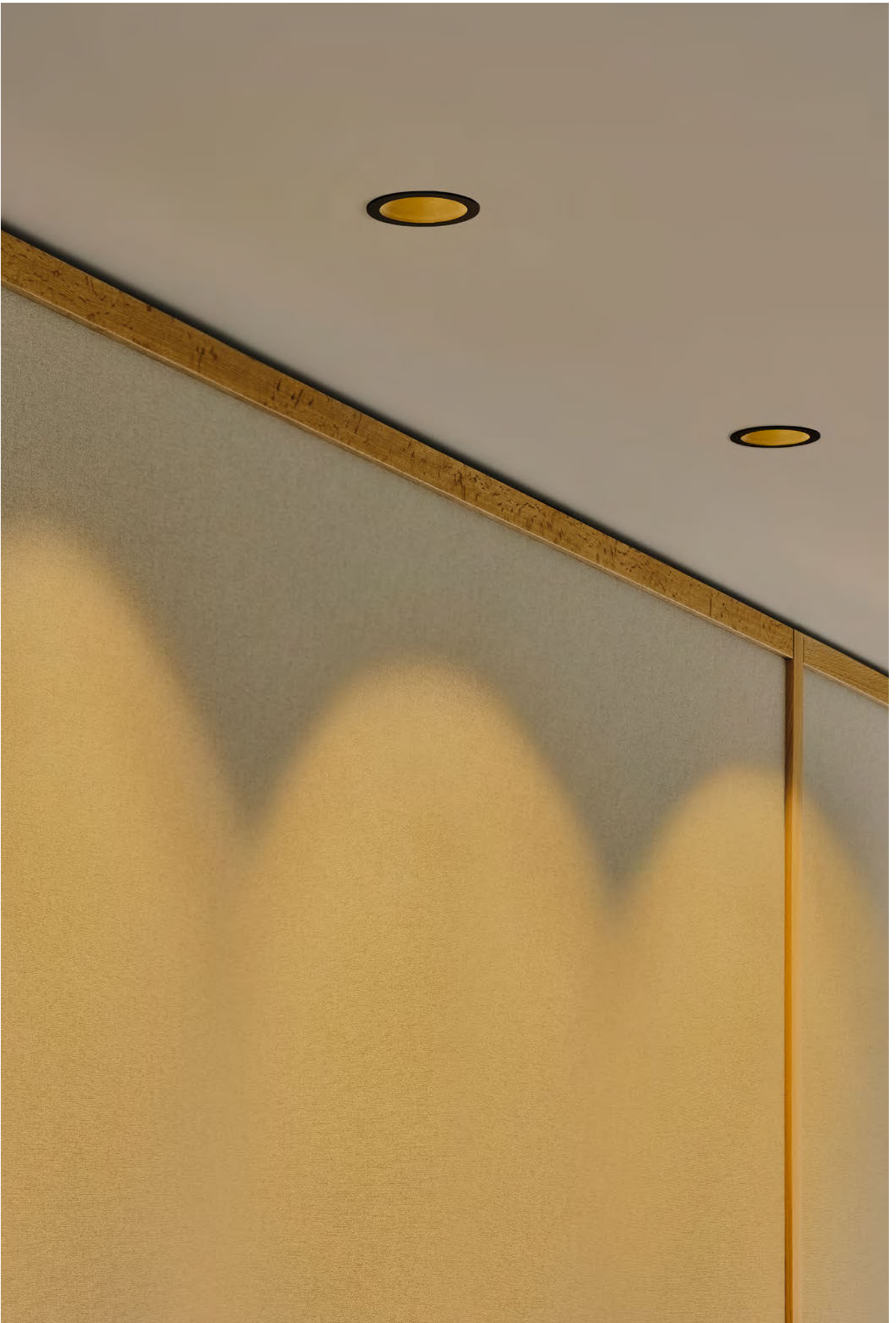

Play High Visual Confort in the Hotel Mon Sant Benet project. Photography: Marta Vidal.
Play High Visual Confort dans le projet Hôtel Mon Sant Benet. Photographie : Marta Vidal.

Premium materials and
attention to detail
Matériaux nobles et détails
soignés

The collection's materials and finishes have been painstakingly crafted by our expert manufacturing technicians.

La collection comprend des matériaux et des finitions travaillés dans les moindres détails avec le soin des mains expertes de nos techniciens de fabrication



Sustainable product Produit durable



Play comes with the Environmental Product Declaration (EPD), a certificate demonstrating the product's environmental impact throughout its life cycle, and the ENEC certification, attesting to the product's quality and safety in compliance with European standards.

Play bénéficie de la déclaration DEP qui enregistre l'impact environnemental du produit tout au long de sa durée de vie, ainsi que du label ENEC qui démontre la qualité et la sécurité du produit conformément aux normes européennes.



SDG (Sustainable Development Goals) Commitment Engagements ODD (Objectifs de développement durable)



Energy Efficiency Efficacité énergétique

The piece's composition promotes heat dissipation and allows you to adjust consumption by adjusting the brightness.
La composition de la pièce favorise la dissipation de la chaleur et permet d'ajuster la consommation en régulant l'intensité lumineuse.

Recyclable Material Matériau recyclable

Made of recyclable products and/or products from recyclable sources.
Utilisation de produits recyclables et/ou issus de sources recyclables.

Sustainable Design Conception durable

Easily changeable LED module and control mechanism to extend the product's lifespan.
Remplacement facile du module LED et du mécanisme de contrôle pour augmenter la durée de vie utile du produit.

Waste separation Tri des déchets

Play's components can be disassembled to easily sort waste.
Play permet le démontage des composants pour faciliter la gestion des déchets.

Modules / Modules

1,5W

3,2W



Frames / Cadres

[F] Fixed [A] Adjustable

Flat	High Visual Confort	IP65	Pinhole	Soft	Snoot	Raw Racy Gold	Raw
P. 203	P. 205	P. 206	P. 209	P. 210	P. 211	P. 212	P. 213
AG33 [F] Trim	AG36 / AG41 [F] Trim/Trimless	AG37 [F] Trim	AG61 [F] Trim			AG66 [F] Trim	AG67 [F] Trim
							
Ø 45 mm	Ø 45/36 mm	Ø 50 mm	Ø 65 mm			Ø 65 mm	Ø 65 mm
○ ● 14 60	○ ● 14 60	○ ● 14 60	○ ● 14 60			○ ● EP	○ ● ● 55 EN EO
AG34 [A] Trim			AG62 [A] Trim	AG64 [A] Trim	AG65 [A] Trim		
							
Ø 52 mm			Ø 65 mm	Ø 65 mm	Ø 70 mm		
○ ● ● 14 60 AF			○ ● 14 60	○ ● 14 60	○ ● 14 60		
AG38 [F] Trim							
							
Ø 45 mm							
○ ● 14 60							
AG39 [A] Trim							
							
Ø 52 mm							
○ ● 14 60							

Finishes / Finitions

- 14 White / Blanc
- 60 Black / Noir
- 21 Chrome / Chromé
- AF Satin aluminium / Aluminium satiné
- DC Cement / Ciment
- EP Deep gold/ Or intense
- EN Walnut wood / Bois de noyer
- 55 Alabaster / Albâtre
- EO Oak wood / Bois de chêne

6,4W

11,9W

Tunable White

17,7W

GU10



Frames / Cadres

[F] Fixed [A] Adjustable

Flat

Deep

High Visual Confort

IP65

IP65 Glass

Pinhole

Soft

Snoot

P. 202

P. 204

P. 205

P. 206

P. 207

P. 208

P. 210

P. 211

AG11

[F] Trim



Ø 65 mm



AG12

[A] Trim



Ø 78 mm



AG15

[F] Trim



Ø 65 mm



AG17

[A] Trimless



Ø 75 mm



AG13

[F] Trim



Ø 90 mm



AG14

[A] Trim



Ø 100 mm



AG16

[F] Trim



Ø 93 mm



AG43

[F] Trim



Ø 92 mm



AG45

[F] Trim



Ø 88 mm



AG47

[A] Trim



Ø 88 mm



AG52 / AG53

[A] Trim/Trimless



Ø 95/95 mm



AG56 / AG57

[A] Trim/Trimless



Ø 95/86 mm



AG19

[F] Trim



Ø 65 mm



AG22

[F] Trim



Ø 93 mm



AG44

[F] Trim



Ø 92 mm



AG46

[F] Trim



Ø 85 mm



AG21

[A] Trim



Ø 78 mm



AG48

[A] Trim



Ø 85 mm



AG55

[A] Trim



Ø 95 mm



Modules / Modules

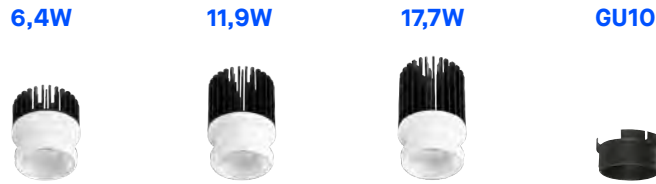

Frames / Cadres

[F] Fixed [A] Adjustable

Raw Racy Gold

P. 212

AG58
[F] Trim



Ø 110 mm
EP

Raw

P. 213

AG59
[F] Trim



Ø 110 mm
55 EN EO DC

Deco Symmetrical

P. 214/215

AG23 / AG24
[F] Trim/Trimless



Ø 90/74 mm
WR WG WH WJ WI
WK WN WL WM

Deco Asymmetrical

P. 216/217

AG25 / AG26
[F] Trim/Trimless



Ø 90/74 mm
WR WG WH WJ WI
WK WN WL WM

Deco Double

P. 218

AG42
[A] Trim



193 × 103 mm
14 60 23

Deco Surface

P. 283

AG32
[F] Surface



Ø 72.5 mm
WR WG WH WJ WI
WK WN WL WM

AG69

[A] Surface



Ø 72.5 mm
WR WG WH WJ WI
WK WN WL WM

AG27 / AG28

[F] Trim/Trimless



Ø 110/74 mm
WR WG WH WJ WI
WK WN WL WM

AG29 / AG31

[F] Trim/Trimless



Ø 110/74 mm
WR WG WH WJ WI
WK WN WL WM

AG68

[F] Pendant
P. 271



Ø 72.5 mm
WR WG WH WJ WI
WK WN WL WM

AG71

[A] 3-Phase Track



Ø 72.5 mm
WR WG WH WJ WI
WK WN WL WM

Finishes / Finitions

- 14 White / Blanc
- 60 Black / Noir
- WR White/White / Blanc/Blanc
- WG White/Gold / Blanc/Or
- WH Black/White / Noir/Blanc
- WI Gold/White / Or/Blanc
- WJ Gold/Gold / Or/Or
- WK Gold/Black / Or/Noir
- WL Black/White / Noir/Blanc
- WM Black/Gold / Noir/Or
- WP Trimless/White / Trimless/Blanc
- WS Trimless/Gold / Trimless/Or
- WQ Trimless/Negro / Trimless/Noir
- WN Black/Black / Noir/Noir
- 23 Gold / Or

Play configurator

Configurateur Play



play.leds-c4.com

INDOOR

Infinite configuration options in a quick and easy way thanks to our online configurator.

Une infinité d'options de configuration de manière simple et rapide grâce à notre configurateur en ligne.



1 Select modules
Sélectionner les modules

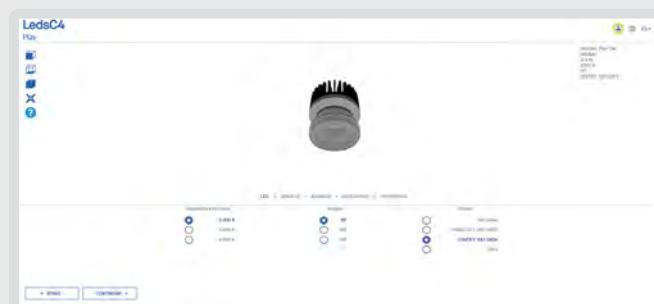

2 Select colour temperature, angle and drivers
Sélectionnez la température de couleur, l'angle et les conducteurs

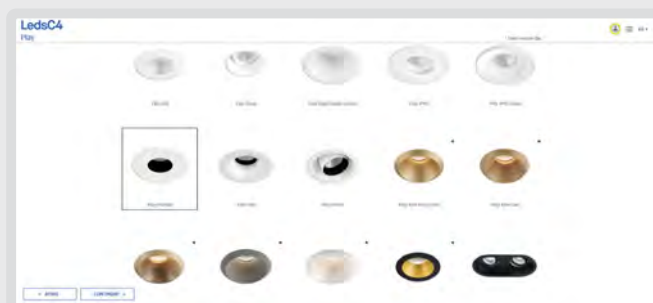

3 Select frames
Sélectionner les cadres

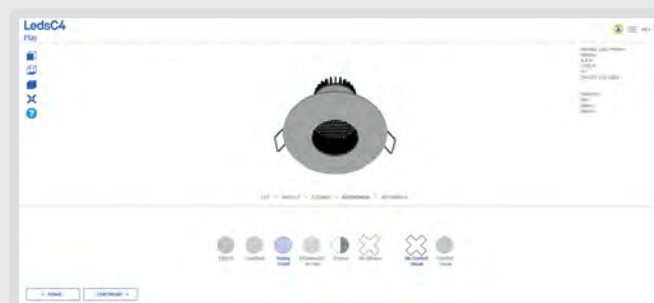

4 Select accessories
Sélectionner les accessoires

5 Documentation download
Télécharger de la documentation

DOWNLIGHTS

Play Best Sellers

Play Flat Round Fixed



58

W LED	K	CRI	Optics	Source	Finishes
6.4W	3000K	90	28°	ON-OFF DALI-2	AG11-P7W9M2OUXX 14 ○ AG11-P7W9M2DSXX 60 ●
11.9W	3000K	90	34°	ON-OFF DALI-2	AG11-13W9M2OUXX 14 ○ AG11-13W9M2DSXX 60 ●

Play Flat Round Adjustable

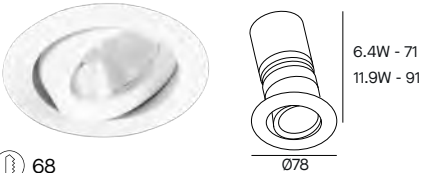

68

W LED	K	CRI	Optics	Source	Finishes
6.4W	3000K	90	28°	ON-OFF DALI-2	AG12-P7W9M2OUXX 14 ○ AG12-P7W9M2DSXX 60 ●
11.9W	3000K	90	34°	ON-OFF DALI-2	AG12-13W9M2OUXX 14 ○ AG12-13W9M2DSXX 60 ●

Play High Visual Confort Round Fixed

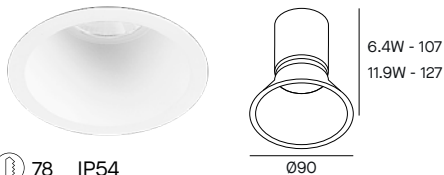

78 IP54

W LED	K	CRI	Optics	Source	Finishes
6.4W	3000K	90	28°	ON-OFF DALI-2	AG13-P7W9M2OUXX 14 ○ AG13-P7W9M2DSXX 60 ●
11.9W	3000K	90	34°	ON-OFF DALI-2	AG13-13W9M2OUXX 14 ○ AG13-13W9M2DSXX 60 ●

Play High Visual Confort Round Adjustable

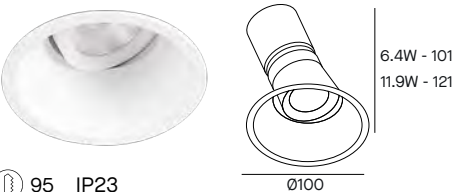

95 IP23

W LED	K	CRI	Optics	Source	Finishes
6.4W	3000K	90	28°	ON-OFF DALI-2	AG14-P7W9M2OUXX 14 ○ AG14-P7W9M2DSXX 60 ●
11.9W	3000K	90	34°	ON-OFF DALI-2	AG14-13W9M2OUXX 14 ○ AG14-13W9M2DSXX 60 ●

Play Deep Round Fixed



58 IP54

W LED	K	CRI	Optics	Source	Finishes
6.4W	3000K	90	28°	ON-OFF DALI-2	AG15-P7W9M2OUXX 14 ○ AG15-P7W9M2DSXX 60 ●
11.9W	3000K	90	34°	ON-OFF DALI-2	AG15-13W9M2OUXX 14 ○ AG15-13W9M2DSXX 60 ●

Play IP65 Round Fixed

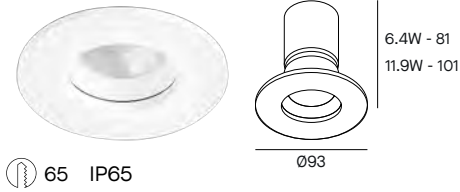

65 IP65

W LED	K	CRI	Optics	Source	Finishes
6.4W	3000K	90	28°	ON-OFF DALI-2	AG16-P7W9M2OUXX AG16-P7W9M2DSXX 14 ○ 60 ●
11.9W	3000K	90	34°	ON-OFF DALI-2	AG16-13W9M2OUXX AG16-13W9M2DSXX 14 ○ 60 ●

Play IP65 Glass Round Fixed

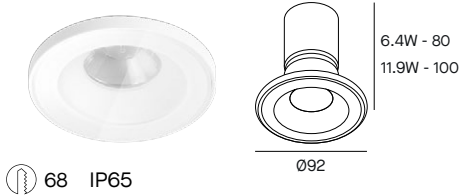

68 IP65

W LED	K	CRI	Optics	Source	Finishes
6.4W	3000K	90	28°	ON-OFF DALI-2	AG43-P7W9M2OU14 AG43-P7W9M2DS14 14 ○
11.9W	3000K	90	34°	ON-OFF DALI-2	AG43-13W9M2OU14 AG43-13W9M2DS14 14 ○

Play Pinhole Round Fixed

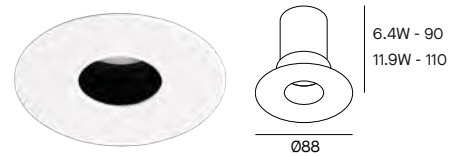

75 IP54

W LED	K	CRI	Optics	Source	Finishes
6.4W	3000K	90	28°	ON-OFF DALI-2	AG45-P7W9M2OU14 AG45-P7W9M2DS14 14 ○
11.9W	3000K	90	34°	ON-OFF DALI-2	AG45-13W9M2OU14 AG45-13W9M2DS14 14 ○

Play Pinhole Round Adjustable

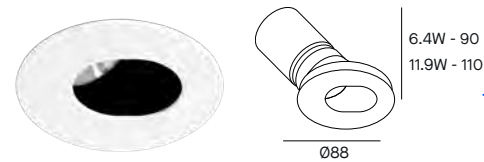

75

W LED	K	CRI	Optics	Source	Finishes
6.4W	3000K	90	28°	ON-OFF DALI-2	AG47-P7W9M2OU14 AG47-P7W9M2DS14 14 ○
11.9W	3000K	90	34°	ON-OFF DALI-2	AG47-13W9M2OU14 AG47-13W9M2DS14 14 ○

Play Soft Round Adjustable

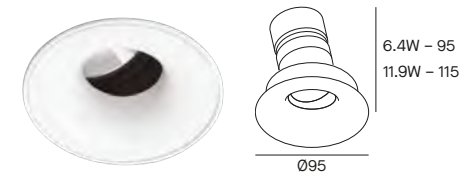

86 IP23

W LED	K	CRI	Optics	Source	Finishes
6.4W	3000K	90	28°	ON-OFF DALI-2	AG52-P7W9M2OUXX AG52-P7W9M2DSXX 14 ○ 60 ●
11.9W	3000K	90	34°	ON-OFF DALI-2	AG52-13W9M2OUXX AG52-13W9M2DSXX 14 ○ 60 ●

Play Snoot Round Adjustable

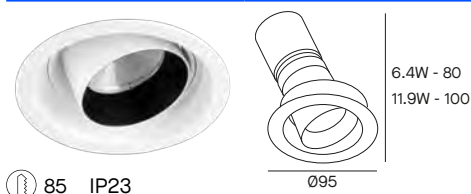

85 IP23

W LED	K	CRI	Optics	Source	Finishes
6.4W	3000K	90	28°	ON-OFF DALI-2	AG56-P7W9M2OUXX AG56-P7W9M2DSXX 14 ○ 60 ●
11.9W	3000K	90	34°	ON-OFF DALI-2	AG56-13W9M2OUXX AG56-13W9M2DSXX 14 ○ 60 ●

BODY MAT
PC,AL

Play Flat

IP	LED
54	

Code example / Exemple d'élaboration d'une référence: **AG11-P7V9S10U14**

Model		W	K	CRI	Lm	Optics	Source	Finishes										
<p>AG11 - Round Fixed</p> <p>14 60</p> <p>0-7 mm</p> <p>58</p> <table border="1"> <tr> <th>W</th> <th>X (mm)</th> </tr> <tr> <td>7</td> <td>65</td> </tr> <tr> <td>13</td> <td>85</td> </tr> <tr> <td>18</td> <td>105</td> </tr> <tr> <td>GU10</td> <td>75</td> </tr> </table>	W	X (mm)	7	65	13	85	18	105	GU10	75	P7V9	6.4	2700	90	526-582	S2 15°	OU ON-OFF 100-240V	14
	W	X (mm)																
	7	65																
	13	85																
	18	105																
	GU10	75																
	P7W9	6.4	3000	90	610-674	M2 28°	TS PHASE CUT 220-240V	60										
	P7X9	6.4	4000	90	610-674	F1 49°	DS DALI-2/PUSH 100-240V	AF										
							BB 9V/max.700mA											
P7V9	8.5	2700	90	511	S1 8°	OU ON-OFF 100-240V												
P7W8	8.5	3000	90	549		TS PHASE CUT 220-240V												
P7X8	8.5	4000	90	587		DS DALI-2 / PUSH 100-240V												
						BB 12V/max.700mA												
<p>AG12 - Round Adjustable</p> <p>14 60 AF</p> <p>0-12 mm</p> <p>68</p> <table border="1"> <tr> <th>W</th> <th>X (mm)</th> </tr> <tr> <td>7</td> <td>70</td> </tr> <tr> <td>13</td> <td>90</td> </tr> <tr> <td>18</td> <td>110</td> </tr> <tr> <td>GU10</td> <td>80</td> </tr> </table>	W	X (mm)	7	70	13	90	18	110	GU10	80	13V9	11.9	2700	90	941-1235	S2 20°	OU ON-OFF 100-240V	
	W	X (mm)																
	7	70																
	13	90																
	18	110																
	GU10	80																
	13W9	11.9	3000	90	1167-1330	M2 33°	TS PHASE CUT 220-240V											
	13X9	11.9	4000	90	1248-1423	F1 44°	DS DALI-2/PUSH 100-240V											
							BB 36V/max.350mA											
18V9	19.8	2700	90	1346-1707	S2 20°	OU ON-OFF 100-240V												
18W9	19.8	3000	90	1449-1722	M2 33°	TS PHASE CUT 220-240V												
18X9	19.8	4000	90	1550-1856	F1 47°	DS DALI-2/PUSH 100-240V												
						BB 36V/max.500mA												
<p>AG19 - Square Fixed</p> <p>14 60</p> <p>0-7 mm</p> <p>58</p> <table border="1"> <tr> <th>W</th> <th>X (mm)</th> </tr> <tr> <td>7 W</td> <td>65</td> </tr> <tr> <td>13 W</td> <td>85</td> </tr> <tr> <td>18 W</td> <td>105</td> </tr> <tr> <td>GU10</td> <td>75</td> </tr> </table>	W	X (mm)	7 W	65	13 W	85	18 W	105	GU10	75	12U9	14.5	TW 2700- 5000	90	955-1088	S2 20°	TW DALI DT8 220-240V	
	W	X (mm)																
	7 W	65																
	13 W	85																
	18 W	105																
	GU10	75																
							M2 33°											
							F1 44°											
	AAG1	GU10	Max. 8W				NA	BU 220-240V										
<p>AG21 - Square Adjustable</p> <p>14 60</p> <p>0-20 mm</p> <p>68</p> <table border="1"> <tr> <th>W</th> <th>X (mm)</th> </tr> <tr> <td>7 W</td> <td>70</td> </tr> <tr> <td>13 W</td> <td>90</td> </tr> <tr> <td>18 W</td> <td>110</td> </tr> <tr> <td>GU10</td> <td>80</td> </tr> </table>	W	X (mm)	7 W	70	13 W	90	18 W	110	GU10	80								
	W	X (mm)																
	7 W	70																
	13 W	90																
	18 W	110																
	GU10	80																

Play Flat Mini

IP	DIF MAT	50000h	2		
54	PMMA	L80 B20	MacAdam		

Code example / Exemple d'élaboration d'une référence: **AG33-P2V8S10U14**

Model		W	K	CRI	Lm	Optics	Source	Finishes
<p>AG33 - Round Fixed</p> <p>Ø45</p> <p>14 60</p> <p>0-8 mm</p> <p>40</p> <p>w X (mm)</p> <p>1.5 40</p> <p>3 30</p>	P2V8	1.5	2700	80	116	S1 15°	OS ON-OFF 220-240V	14
	P2W8	1.5	3000	80	116		DS DALI-2/PUSH 100-240V	60
	P2X8	1.5	4000	80	116		BB 3V/max.500mA	AF
	P3V8	3.2	2700	80	319-353	M2 28°	OS ON-OFF 220-240V	
	P3W8	3.2	3000	80	308-353	F1 47°	DS DALI-2/PUSH 100-240V	
	P3X8	3.2	4000	80	347		BB 9V/max.350mA	
<p>AG34 - Round Adjustable</p> <p>Ø52</p> <p>14 60 AF</p> <p>0-12 mm</p> <p>42</p> <p>w X (mm)</p> <p>1.5 45</p> <p>3 35</p>								
<p>AG38 - Square Fixed</p> <p>45</p> <p>14 60</p> <p>0-12 mm</p> <p>42</p> <p>w X (mm)</p> <p>1.5 40</p> <p>3 30</p>								
<p>AG39 - Square Adjustable</p> <p>52</p> <p>14 60</p> <p>0-12 mm</p> <p>42</p> <p>w X (mm)</p> <p>1.5 40</p> <p>3 30</p>								

Play Deep

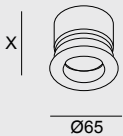
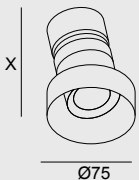

Code example / Exemple d'élaboration d'une référence: **AG15-P7V9S10U14**

Model	W	K	CRI	Lm	Optics	Source	Finishes										
 <p>AG15 - Round Fixed 0-20 mm 58</p> <p>Ø65</p> <p>w x (mm)</p> <table border="1"> <tr><td>7</td><td>80</td></tr> <tr><td>13</td><td>100</td></tr> <tr><td>18</td><td>120</td></tr> <tr><td>GU10</td><td>90</td></tr> </table>	7	80	13	100	18	120	GU10	90	P7V9	6.4	2700	90	473-573	S2 15°	OU ON-OFF 100-240V	14 60	
	7	80															
	13	100															
	18	120															
	GU10	90															
	P7W9	6.4	3000	90	548-663	M2 28°	TS PHASE CUT 220-240V										
	P7X9	6.4	4000	90	548-663	F1 49°	DS DALI-2/PUSH 100-240V										
							BB 9V/max.700mA										
	 <p>AG17 - Round Adjustable Trimless 0-18 mm 75</p> <p>Ø75</p> <p>w x (mm)</p> <table border="1"> <tr><td>7</td><td>95</td></tr> <tr><td>13</td><td>115</td></tr> <tr><td>18</td><td>135</td></tr> <tr><td>GU10</td><td>105</td></tr> </table>	7	95	13	115	18	135	GU10	105	P7V9	8.5	2700	90	496	S1 8°	OU ON-OFF 100-240V	
		7	95														
		13	115														
		18	135														
GU10		105															
P7W9		8.5	3000	90	533		TS PHASE CUT 220-240V										
P7X9		8.5	4000	90	570		DS DALI-2/PUSH 100-240V										
							BB 12V/max. 700mA										
13V9		11.9	2700	90	998-1229	S2 20°	OU ON-OFF 100-240V										
13W9		11.9	3000	90	1074-1323	M2 33°	TS PHASE CUT 220-240V										
13X9		11.9	4000	90	1149-1415	F1 44°	DS DALI-2/PUSH 100-240V										
							BB 36V/max.350mA										
18V9	19.8	2700	90	1295-1557	S2 20°	OU ON-OFF 100-240V											
18W9	19.8	3000	90	1394-1676	M2 33°	TS PHASE CUT 220-240V											
18X9	19.8	4000	90	1492-1793	F1 47°	DS DALI-2/PUSH 100-240V											
						BB 36V/max.500mA											
12U9	14.5	TW 2700 6500	90	879-1082	S2 20° M2 33° F1 44°	TW DALI DT8 220-240V											
AAG1	GU10	Max. 8W			NA	BU 220-240V											



Play High Visual Comfort

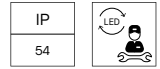

Code example / Exemple d'élaboration d'une référence: **AG13-P7V9S10U14**

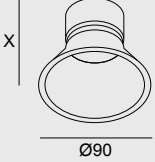
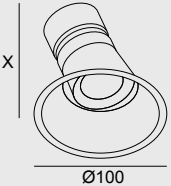
Model		W	K	CRI	Lm	Optics	Source	Finishes								
 <p>AG13 - Round Fixed 0-25 mm 78</p> <p>W X (mm)</p> <table border="1"> <tr><td>7</td><td>105</td></tr> <tr><td>13</td><td>125</td></tr> <tr><td>18</td><td>145</td></tr> <tr><td>GU10</td><td>115</td></tr> </table>	7	105	13	125	18	145	GU10	115	P7V9	6.4	2700	90	498-569	S2 15°	OU ON-OFF 100-240V	14
	7	105														
	13	125														
	18	145														
	GU10	115														
	P7W9	6.4	3000	90	577-659	M2 28°	TS PHASE CUT 100-240V	60								
	P7X9	6.4	4000	90	577-659	F1 49°	DS DALI-2/PUSH 220-240V									
	P7V9	8.5	2700	90	497	S1 8°	OU ON-OFF 100-240V									
	P7W9	8.5	3000	90	534	TS	PHASE CUT 100-240V									
P7X9	8.5	4000	90	571	DS	DALI-2/PUSH 100-240V										
						BB	9V/max.700mA									
 <p>AG14 - Round Adjustable 0-18 mm 90</p> <p>W X (mm)</p> <table border="1"> <tr><td>7</td><td>100</td></tr> <tr><td>13</td><td>120</td></tr> <tr><td>18</td><td>140</td></tr> <tr><td>GU10</td><td>110</td></tr> </table>	7	100	13	120	18	140	GU10	110	13V9	11.9	2700	90	1015-1217	S2 20°	OU ON-OFF 100-240V	
	7	100														
	13	120														
	18	140														
	GU10	110														
	13W9	11.9	3000	90	1092-1310	M2 33°	TS PHASE CUT 100-240V									
	13X9	11.9	4000	90	1116-1402	F1 47°	DS DALI-2/PUSH 100-240V									
							BB	36V/max.350mA								
	18V9	17.7	2700	90	1280-1587	S2 20°	OU ON-OFF 100-240V									
	18W9	17.7	3000	90	1378-1708	M2 33°	TS PHASE CUT 100-240V									
18X9	17.7	4000	90	1474-1828	F1 44°	DS DALI-2 / PUSH 220-240V										
						BB	36V/max.500mA									
12U9	14.5	TW 2700 6500	90	894-1072	S2 20° M2 33° F1 44°	TW DALI DT8 220-240V										
AAG1	GU10	Max. 8W			NA	BU 220-240V										

 **Play Emergency**
1 P. 944

Play High Visual Comfort Mini

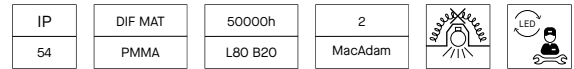

Code example / Exemple d'élaboration d'une référence: **AG36-P2V8S10U14**

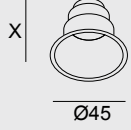
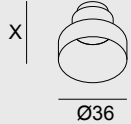
Model		W	K	CRI	Lm	Optics	Source	Finishes				
 <p>AG36 - Round Fixed 0-15 mm 40</p> <p>W X (mm)</p> <table border="1"> <tr><td>1.5</td><td>60</td></tr> <tr><td>3</td><td>50</td></tr> </table>	1.5	60	3	50	P2V8	1.5	2700	80	113-117	S1 8°	OS ON-OFF 220-240V	14
	1.5	60										
	3	50										
	P2W8	1.5	3000	80	113-117		DS DALI-2/PUSH 100-240V	60				
	P2X8	1.5	4000	80	113-117		BB 3V/max.500mA					
	P3V8	3.2	2700	80	318-350	M2 28°	OS ON-OFF 220-240V					
P3W8	3.2	3000	80	299-350	F1 47°	DS DALI-2/PUSH 100-240V						
P3X8	3.2	4000	80	332		BB 9V/max.350mA						
 <p>AG41* - Round Adjustable Trimless 0-14 mm 36</p> <p>W X (mm)</p> <table border="1"> <tr><td>1.5</td><td>50</td></tr> <tr><td>3</td><td>40</td></tr> </table>	1.5	50	3	40								
1.5	50											
3	40											

* AG41, DALI-2 unavailable / AG41, non disponible DALI-2

BODY MAT
PC,AL

Play IP65

IP	
65	

Code example / Exemple d'élaboration d'une référence: **AG16-P7V9S10U14**

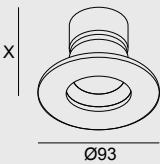
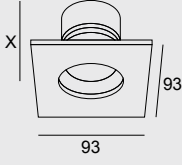
Model		W	K	CRI	Lm	Optics	Source	Finishes										
 <p>AG16 - Round Fixed 0-20 mm Ø 65 14 60 21</p> <table border="1"> <tr><th>w</th><th>x (mm)</th></tr> <tr><td>7</td><td>80</td></tr> <tr><td>13</td><td>100</td></tr> <tr><td>18</td><td>120</td></tr> <tr><td>GU10</td><td>90</td></tr> </table>	w	x (mm)	7	80	13	100	18	120	GU10	90	P7V9	6.4	2700	90	489-543	S2 15°	OU ON-OFF 100-240V	14
	w	x (mm)																
	7	80																
	13	100																
	18	120																
	GU10	90																
	P7W9	6.4	3000	90	549-629	M2 28°	TS PHASE CUT 220-240V	60										
	P7X9	6.4	4000	90	566-629	F1 49°	DS DALI-2/PUSH 100-240V	21										
							BB 9V/max.700mA											
	P7V8	8.5	2700	90	511	S1 8°	OU ON-OFF 100-240V											
	P7W8	8.5	3000	90	549		TS PHASE CUT 220-240V											
	P7X8	8.5	4000	90	587		DS DALI-2/PUSH 100-240V											
						BB 12V/max.700mA												
 <p>AG22 - Square Fixed 0-20 mm Ø 65 14 60</p> <table border="1"> <tr><th>w</th><th>x (mm)</th></tr> <tr><td>7</td><td>80</td></tr> <tr><td>13</td><td>100</td></tr> <tr><td>18</td><td>120</td></tr> <tr><td>GU10</td><td>90</td></tr> </table>	w	x (mm)	7	80	13	100	18	120	GU10	90	13V9	11.9	2700	90	941-1163	S2 20°	OU ON-OFF 100-240V	
	w	x (mm)																
	7	80																
	13	100																
	18	120																
	GU10	90																
	13W9	11.9	3000	90	1069-1251	M2 33°	TS PHASE CUT 220-240V											
	13X9	11.9	4000	90	1144-1399	F1 44°	DS DALI-2/PUSH 100-240V											
							BB 36V/max.350mA											
	18V9	17.7	2700	90	1248-1506	S2 20°	OU ON-OFF 100-240V											
18W9	17.7	3000	90	1343-1622	M2 33°	TS PHASE CUT 220-240V												
18X9	17.7	4000	90	1367-1735	F1 47°	DS DALI-2/PUSH 100-240V												
						BB 36V/max.500mA												
12U9	14.5	TW 2700 6500	90	875-1024	S2 20° M2 33° F1 44°	TW DALI DT8 220-240V												
AAG1	GU10	Max. 8W			NA	BU 220-240V												

Play Emergency
P. 945

Play IP65 Mini

IP	DIF MAT	50000h	2	
65	PMMA	L80 B20	MacAdam	



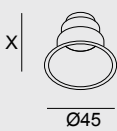







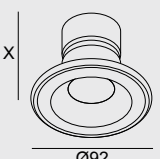





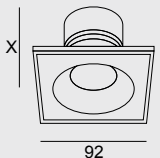



Code example / Exemple d'élaboration d'une référence: **AG37-P2V8S10U14**

Model		W	K	CRI	Lm	Optics	Source	Finishes						
 <p>AG37 - Round Fixed 0-15 mm Ø 40</p> <table border="1"> <tr><th>w</th><th>x (mm)</th></tr> <tr><td>1,5</td><td>60</td></tr> <tr><td>3</td><td>50</td></tr> </table>	w	x (mm)	1,5	60	3	50	P2V8	1.5	2700	80	112	S1 8°	OS ON-OFF 220-240V	14
	w	x (mm)												
	1,5	60												
	3	50												
	P2W8	1.5	3000	80	112		DS DALI-2/PUSH 220-240V	60						
	P2X8	1.5	4000	80	112		BB 3V/max.500mA							
P3V8	3.2	2700	80	287-316	M2 28°	OS ON-OFF 220-240V								
P3W8	3.2	3000	80	278-316	F1 47°	DS DALI-2/PUSH 220-240V								
P3X8	3.2	4000	80	306		BB 9V/max.350mA								

Play Glass

IP	DIF MAT
65	GLA

Code example / Exemple d'élaboration d'une référence: **AG43-P7V9S10U14**

Model	W	K	CRI	Lm	Optics	Source	Finishes
 <p>AG43 - Round Fixed 0-20 mm Ø 68 W X (mm) 7 80 13 100</p>	P7V9	6.4	2700	90	483-514	S2 15° OU  ON-OFF 100-240V	14 
	P7W9	6.4	3000	90	549-596	M2 28° TS  PHASE CUT 220-240V	
	P7X9	6.4	4000	90	560-596	F1 49° DS  DALI-2/PUSH 100-240V BB  9V/max.700mA	
 <p>AG44 - Square Fixed 0-20 mm Ø 68 W X (mm) 7 80 13 100 18 120 GU10 90</p>	P7V9	8.5	2700	90	511	S1 8° OU  ON-OFF 100-240V	
	P7W9	8.5	3000	90	549	TS  PHASE CUT 220-240V	
	P7X9	8.5	4000	90	587	DS  DALI-2/PUSH 100-240V BB  12V/max.700mA	
	13V9	11.9	2700	90	864-1094	S2 20° OU  ON-OFF 100-240V	
	13W9	11.9	3000	90	1079-1178	M2 33° TS  PHASE CUT 220-240V	
	13X9	11.9	4000	90	1154-1260	F1 44° DS  DALI-2/PUSH 100-240V BB  36V/max.350mA	
	18V9	17.7	2700	90	1244-1621	S2 20° OU  ON-OFF 100-240V	
	18W9	17.7	3000	90	1340-1621	M2 33° TS  PHASE CUT 220-240V	
	18X9	17.7	4000	90	1433-1621	F1 47° DS  DALI-2/PUSH 100-240V BB  36V/max.500mA	
	12U9	14.5	TW 2700 6500	90	883-964	S2 20° TW  DALI DT8 220-240V M2 33° F1 44°	
AAG1	GU10	Max. 8W			NA BU  220-240V		

BODY MAT
PC,AL

Play Pinhole

IP			
54			

Code exemple / Exemple d'élaboration d'une référence: **AG45-P7V9S10U14**







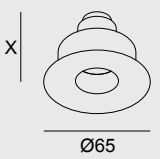

Model		W	K	CRI	Lm	Optics	Source	Finishes										
 AG45 - Round Fixed 0-18 mm Ø 75 <table border="1"> <tr><th>W</th><th>X (mm)</th></tr> <tr><td>7</td><td>90</td></tr> <tr><td>13</td><td>110</td></tr> <tr><td>18</td><td>130</td></tr> <tr><td>GU10</td><td>100</td></tr> </table>	W	X (mm)	7	90	13	110	18	130	GU10	100	P7V9	6.4	2700	90	279-317	S2 15°	OU ON-OFF 100-240V	14
	W	X (mm)																
	7	90																
	13	110																
	18	130																
	GU10	100																
	P7W9	6.4	3000	90	324-368	M2 28°	TS PHASE CUT 220-240V											
	P7X9	6.4	4000	90	324-368	F1 49°	DS DALI-2/PUSH 100-240V											
							BB 9V/max.700mA											
P7V9	8.5	2700	90	458	S1 8°	OU ON-OFF 100-240V												
P7W9	8.5	3000	90	493		TS PHASE CUT 220-240V												
P7X9	8.5	4000	90	528		DS DALI-2/PUSH 100-240V												
						BB 12V/max.700mA												
 AG46 - Square Fixed 0-18 mm 75x55 <table border="1"> <tr><th>W</th><th>X (mm)</th></tr> <tr><td>7</td><td>90</td></tr> <tr><td>13</td><td>110</td></tr> <tr><td>18</td><td>130</td></tr> <tr><td>GU10</td><td>100</td></tr> </table>	W	X (mm)	7	90	13	110	18	130	GU10	100	13V9	11.9	2700	90	873-1091	S2 20°	OU ON-OFF 100-240V	
	W	X (mm)																
	7	90																
	13	110																
	18	130																
	GU10	100																
	13W9	11.9	3000	90	928-1160	M2 33°	TS PHASE CUT 220-240V											
	13X9	11.9	4000	90	1003-1253	F1 44°	DS DALI-2/PUSH 100-240V											
							BB 36V/max.350mA											
18V9	17.7	2700	90	1056-1357	S2 20°	OU ON-OFF 100-240V												
18W9	17.7	3000	90	1123-1444	M2 33°	TS PHASE CUT 220-240V												
18X9	17.7	4000	90	1213-1559	F1 47°	DS DALI-2/PUSH 100-240V												
						BB 36V/max.500mA												
 AG47 - Round Adjustable 0-18 mm 75x55 <table border="1"> <tr><th>W</th><th>X (mm)</th></tr> <tr><td>7</td><td>90</td></tr> <tr><td>13</td><td>110</td></tr> <tr><td>18</td><td>130</td></tr> <tr><td>GU10</td><td>90</td></tr> </table>	W	X (mm)	7	90	13	110	18	130	GU10	90	12U9	14.5	TW 2700	90 6500	760-949	S2 20°	TW DALI DT8 220-240V	
	W	X (mm)																
	7	90																
	13	110																
	18	130																
	GU10	90																
							M2 33°											
							F1 44°											
 AG48 - Square Fixed 0-18 mm Ø 75 <table border="1"> <tr><th>W</th><th>X (mm)</th></tr> <tr><td>7</td><td>90</td></tr> <tr><td>13</td><td>110</td></tr> <tr><td>18</td><td>130</td></tr> <tr><td>GU10</td><td>100</td></tr> </table>	W	X (mm)	7	90	13	110	18	130	GU10	100	AAG1	GU10	Max. 8W			NA	BU 220-240V	
	W	X (mm)																
	7	90																
	13	110																
	18	130																
	GU10	100																

Play Emergency
 ⓘ P. 946

Play Pinhole Mini

IP	UGR	50000h	2		
54	<16	L80 B20	MacAdam		

Code example / Exemple d'élaboration d'une référence: **AG61-P2V8S10U14**

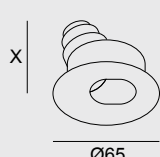
Model		W	K	CRI	Lm	Optics	Source	Finishes
 <p>AG61 - Round Fixed</p> <p>0-15 mm 55</p> <p>W X (mm)</p> <p>1.5 60 3 50</p> <p>Ø65</p>	P2V8	1.5	2700	80	85	S1 8°	OS  ON-OFF 100-277V	14 
	P2W8	1.5	3000	80	85		DS  DALI-2/PUSH 100-240V	60 
	P2X8	1.5	4000	80	85		BB  3V/max.500mA	
	P3V8	3.2	2700	80	249-300	M2 28°	OS  ON-OFF 220-240V	
	P3V8	3.2	3000	80	261-319	F1 47°	DS  DALI-2/PUSH 100-240V	
	P3X8	3.2	4000	80	261-319		BB  9V/max.350mA	
 <p>AG62 - Round Adjustable</p> <p>0-15 mm 55</p> <p>W X (mm)</p> <p>1.5 60 3 50</p> <p>Ø65</p>								

BODY MAT
PC,AL

Play Soft

IP		
54		

Code example / Exemple d'élaboration d'une référence: **AG52-P7V9S10U14**

Model		W	K	CRI	Lm	Optics	Source	Finishes	
 AG52 - Round Fixed 0-20 mm Ø 86 W X (mm) 7 95 13 115 18 135 GU10 85	P7V9	6.4	2700	90	435-532	S2 15°	OU ON-OFF 100-240V	14	
	P7W9	6.4	3000	90	504-616	M2 28°	TS PHASE CUT 220-240V	60	
	P7X9	6.4	4000	90	504-616	F1 49°	DS DALI-2/PUSH 100-240V		
							BB 9V/max.700mA		
	P7V9	8.5	2700	90	478	S1 8°	OU ON-OFF 100-240V		
	P7W9	8.5	3000	90	514	TS	TS PHASE CUT 220-240V		
	P7X9	8.5	4000	90	550	DS	DS DALI-2/PUSH 100-240V		
							BB 12V/max.700mA		
	 AG53 - Square Fixed 0-18 mm Ø 102 W X (mm) 7 95 13 115 18 135 GU10 85	13V9	11.9	2700	90	1035-1164	S2 20°	OU ON-OFF 100-240V	
13W9		11.9	3000	90	1107-1271	M2 33°	TS PHASE CUT 220-240V		
13X9		11.9	4000	90	1195-1360	F1 44°	DS DALI-2/PUSH 100-240V		
							BB 36V/max.350mA		
 AG55 - Round Adjustable 0-18 mm Ø 85 W X (mm) 7 110 13 130 18 150 GU10 100		18V9	17.7	2700	90	1286-1455	S2 20°	OU ON-OFF 100-240V	
		18W9	17.7	3000	90	1368-1548	M2 33°	TS PHASE CUT 220-240V	
	18X9	17.7	4000	90	1478-1671	F1 47°	DS DALI-2/PUSH 100-240V		
							BB 36V/max.500mA		
	12U9	14.5	TW 2700 6500	90	906-1040	S2 20° M2 33° F1 44°	TW DALI DT8 220-240V		
	AAG1	GU10	Max. 8W			NA	BU 220-240V		

Play Emergency
P. 947

Play Soft Mini

IP	UGR	50000h	2			
54	<16	L80 B20	MacAdam		35°	

Code example / Exemple d'élaboration d'une référence: **AG64-P2V8S10U14**

Model		W	K	CRI	Lm	Optics	Source	Finishes
 AG64 - Round Adjustable 0-15 mm Ø 55 W X (mm) 1.5 60 3 50	P2V8	1.5	2700	80	90	S1 8°	OS ON-OFF 220-240V	14
	P2W8	1.5	3000	80	90		DS DALI-2/PUSH 100-240V	60
	P2X8	1.5	4000	80	90		BB 3V/max.500mA	
	P3V8	3.2	2700	80	257-300	M2 28°	OS ON-OFF 220-240V	
	P3V8	3.2	3000	80	274-319	F1 47°	DS DALI-2/PUSH 100-240V	
	P3X8	3.2	4000	80	274-319		BB 9V/max.350mA	

Play Snoot

IP		
54		

Code example / Exemple d'élaboration d'une référence: **AG56-P7V9S10U14**

Model		W	K	CRI	Lm	Optics	Source	Finishes	
 AG56 - Round Adjustable 0-20 mm Ø 85 ±40° ±320° W X (mm) 7 80 13 100 18 120 GU10 70	P7V9	6.4	2700	90	507-552	S2 15°	OU ON-OFF 100-240V	14	
	P7W9	6.4	3000	90	590-641	M2 28°	TS PHASE CUT 220-240V	60	
	P7X9	6.4	4000	90	590-641	F1 49°	DS DALI-2/PUSH 100-240V		
							BB 9V/max.700mA		
	P7V9	8.5	2700	90	485	S1 8°	OU ON-OFF 100-240V		
	P7W9	8.5	3000	90	521		TS PHASE CUT 220-240V		
	P7X9	8.5	4000	90	557		DS DALI-2/PUSH 100-240V		
							BB 12V/max.700mA		
	 AG57 - Round Adjustable Trimless 0-18 mm Ø 87 ±40° ±320° W X (mm) 7 90 13 110 18 125 GU10 90	13V9	11.9	2700	90	1064-1175	S2 20°	OU ON-OFF 100-240V	
		13W9	11.9	3000	90	1132-1250	M2 33°	TS PHASE CUT 220-240V	
13X9		11.9	4000	90	1222-1350	F1 44°	DS DALI-2/PUSH 100-240V		
							BB 36V/max.350mA		
18V9		17.7	2700	90	1344-1485	S2 20°	OU ON-OFF 100-240V		
18W9		17.7	3000	90	1429-1579	M2 33°	TS PHASE CUT 220-240V		
18X9		17.7	4000	90	1544-1706	F1 47°	DS DALI-2/PUSH 100-240V		
							BB 36V/max.500mA		
12U9		14.5	TW 2700 6500	90	926-1023	S2 20° M2 33° F1 44°	TW DALI DT8 220-240V		
AAG1		GU10	Max. 8W			NA	BU 220-240V		

Play Emergency
P. 948

Play Snoot Mini

IP	UGR	50000h	2		
54	<22	L80 B20	MacAdam		

Code example / Exemple d'élaboration d'une référence: **AG65-P2V8S10U14**

Model		W	K	CRI	Lm	Optics	Source	Finishes
 AG65 - Round Adjustable 0-15 mm Ø 60 ±40° ±320° W X (mm) 1.5 50 3 40	P2V8	1.5	2700	80	95	S1 8°	OS ON-OFF 220-240V	14
	P2W8	1.5	3000	80	95		DS DALI-2/PUSH 100-240V	60
	P2X8	1.5	4000	80	95		BB 3V/max.500mA	
	P3V8	3.2	2700	80	282-310	M2 28°	OS ON-OFF 220-240V	
	P3V8	3.2	3000	80	300-329	F1 47°	DS DALI-2/PUSH 220-240V	
	P3X8	3.2	4000	80	300-329		BB 9V/max.350mA	

BODY MAT
PC,AL

Play Raw Gold

IP		
54		

Code example / Exemple d'élaboration d'une référence: **AG58-P7V9S10UEP**

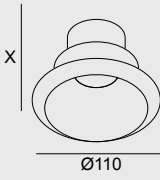
Model		W	K	CRI	Lm	Optics	Source	Finishes										
 <p>AG58 - Round Fixed 0-27 mm 102</p> <table border="1"> <tr><th>w</th><th>X (mm)</th></tr> <tr><td>7</td><td>105</td></tr> <tr><td>13</td><td>125</td></tr> <tr><td>18</td><td>145</td></tr> <tr><td>GU10</td><td>95</td></tr> </table>	w	X (mm)	7	105	13	125	18	145	GU10	95	P7V9	6.4	2700	90	514-549	S2 15°	OU ON-OFF 100-240V	EP
	w	X (mm)																
	7	105																
	13	125																
	18	145																
	GU10	95																
	P7W9	6.4	3000	90	596-636	M2 28°	TS PHASE CUT 220-240V											
	P7X9	6.4	4000	90	596-636	F1 49°	DS DALI-2/PUSH 100-240V											
							BB 9V/max.700mA											
	P7V9	8.5	2700	90	500	S1 8°	OU ON-OFF 100-240V											
	P7W9	8.5	3000	90	538		TS PHASE CUT 220-240V											
	P7X9	8.5	4000	90	576		DS DALI-2/PUSH 100-240V											
							BB 12V/max.700mA											
	13V9	11.9	2700	90	1048-1150	S2 20°	OU ON-OFF 100-240V											
	13W9	11.9	3000	90	1128-1238	M2 33°	TS PHASE CUT 220-240V											
	13X9	11.9	4000	90	1207-1324	F1 44°	DS DALI-2 / PUSH 100-240V											
							BB 36V/max.350mA											
	18V9	17.7	2700	90	1326-1520	S2 20°	OU ON-OFF 100-240V											
18W9	17.7	3000	90	1466-1636	M2 33°	TS PHASE CUT 220-240V												
18X9	17.7	4000	90	1568-1751	F1 47°	DS DALI-2/PUSH 100-240V												
						BB 36V/max.500mA												
12U9	14.5	TW 2700 6500	90	924-1013	S2 20° M2 33° F1 44°	TW DALI DT8 220-240V												
AAG1	GU10	Max. 8W			NA	BU 220-240V												

Play Emergency
P. 949

Play Raw Gold Mini

IP	50000h	2		
54	L80 B20	MacAdam		

Code example / Exemple d'élaboration d'une référence: **AG66-P2V8S10UEP**

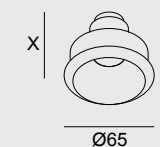
Model		W	K	CRI	Lm	Optics	Source	Finishes						
 <p>AG66 - Round Adjustable 0-16 mm 55</p> <table border="1"> <tr><th>w</th><th>X (mm)</th></tr> <tr><td>1.5</td><td>60</td></tr> <tr><td>3</td><td>50</td></tr> </table>	w	X (mm)	1.5	60	3	50	P2V8	1.5	2700	80	94	S1 8°	OS ON-OFF 220-240V	EP
	w	X (mm)												
	1.5	60												
	3	50												
	P2W8	1.5	3000	80	94		DS DALI-2 220-240V							
	P2X8	1.5	4000	80	94		BB 3V/max.500mA							
P3V8	3.2	2700	80	302-319	M2 28°	OS ON-OFF 220-240V								
P3V8	3.2	3000	80	322-340	F1 47°	DS DALI-2/PUSH 100-240V								
P3X8	3.2	4000	80	322-340		BB 9V/max.350mA								

Play Raw

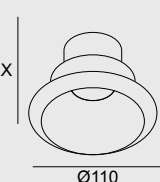

Code example / Exemple d'élaboration d'une référence: **AG59-P7V9S10U55**

Model		W	K	CRI	Lm	Optics	Source	Finishes
 <p>AG59 - Round Fixed 0-27 mm 102 W X (mm) 7 105 13 125 18 145 GU10 95</p>	P7V9	6.4	2700	90	481-537	S2 15°	OU ON-OFF 100-240V	55
	P7W9	6.4	3000	90	560-625	M2 28°	TS PHASE CUT 220-240V	DC
	P7X9	6.4	4000	90	560-625	F1 49°	DS DALI-2/PUSH 100-240V	EN
							BB 9V/max.700mA	EO
	P7V9	8.5	2700	90	492	S1 8°	OU ON-OFF 100-240V	
	P7W9	8.5	3000	90	529		TS PHASE CUT 220-240V	
	P7X9	8.5	4000	90	566		DS DALI-2/PUSH 100-240V	
							BB 12V/max.700mA	
	13V9	11.9	2700	90	1104-1250	S2 20°	OU ON-OFF 100-240V	
	13W9	11.9	3000	90	1175-1330	M2 33°	TS PHASE CUT 220-240V	
	13X9	11.9	4000	90	1269-1437	F1 44°	DS DALI-2/PUSH 100-240V	
							BB 36V/max.350mA	
	18V9	17.7	2700	90	1394-1624	S2 20°	OU ON-OFF 100-240V	
	18W9	17.7	3000	90	1483-1728	M2 33°	TS PHASE CUT 220-240V	
	18X9	17.7	4000	90	1602-1866	F1 47°	DS DALI-2/PUSH 100-240V	
							BB 36V/max.500mA	
12U9	14.5	TW 2700 6500	90	961-1089	S2 20° M2 33° F1 44°	TW DALI DT8 220-240V		
AAG1	GU10	Max. 8W			NA	BU 220-240V		



Play Raw Mini

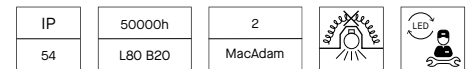

Code example / Exemple d'élaboration d'une référence: **AG67-P2V8S10U55**

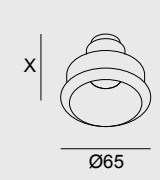
Model		W	K	CRI	Lm	Optics	Source	Finishes
 <p>AG67 - Round Adjustable 0-16 mm 55 W X (mm) 1.5 60 3 50</p>	P2V8	1.5	2700	80	77	S1 8°	OS ON-OFF 220-240V	55
	P2W8	1.5	3000	80	77		DS DALI-2/PUSH 100-240V	EN
	P2X8	1.5	4000	80	77		BB 3V/max.500mA	EO
	P3V8	3.2	2700	80	248-268	M2 28°	OS ON-OFF 220-240V	
	P3V8	3.2	3000	80	264-285	F1 47°	DS DALI-2/PUSH 100-240V	
	P3X8	3.2	4000	80	264-285		BB 9V/max.350mA	

BODY MAT
PC,AL

Play Deco Symmetrical Trim

IP
54

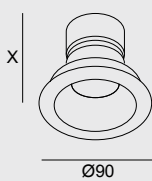
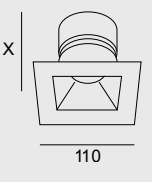

Code example / Exemple d'élaboration d'une référence: **AG23-P7V9S10UWR**

Model		W	K	CRI	Lm	Optics	Source	Finishes										
 <p>AG23 - Round Fixed 0-25 mm Ø 80</p> <table border="1"> <tr><th>W</th><th>X (mm)</th></tr> <tr><td>7</td><td>90</td></tr> <tr><td>13</td><td>110</td></tr> <tr><td>18</td><td>130</td></tr> <tr><td>GU10</td><td>80</td></tr> </table>	W	X (mm)	7	90	13	110	18	130	GU10	80	P7V9	6.4	2700	90	514-575	S2 15°	OU ON-OFF 100-240V	WG
	W	X (mm)																
	7	90																
	13	110																
	18	130																
	GU10	80																
	P7W9	6.4	3000	90	596-666	M2 28°	TS PHASE CUT 220-240V	WH										
	P7X9	6.4	4000	90	596-666	F1 49°	DS DALI-2/PUSH 100-240V	WI										
							BB 9V/max.700mA	WJ										
P7V9	8.5	2700	90	499	S1 8°	OU ON-OFF 100-240V	WK											
P7W9	8.5	3000	90	537		TS PHASE CUT 220-240V	WL											
P7X9	8.5	4000	90	575		DS DALI-2/PUSH 100-240V	WM											
						BB 12V/max.700mA	WN											
 <p>AG27 - Square Fixed 0-25 mm Ø 100</p> <table border="1"> <tr><th>W</th><th>X (mm)</th></tr> <tr><td>7</td><td>90</td></tr> <tr><td>13</td><td>110</td></tr> <tr><td>18</td><td>130</td></tr> <tr><td>GU10</td><td>80</td></tr> </table>	W	X (mm)	7	90	13	110	18	130	GU10	80	13V9	11.9	2700	90	754-935	S2 20°	OU ON-OFF 100-240V	WR
	W	X (mm)																
	7	90																
	13	110																
	18	130																
	GU10	80																
	13W9	11.9	3000	90	1128-1331	M2 33°	TS PHASE CUT 220-240V											
13X9	11.9	4000	90	1207-1424	F1 44°	DS DALI-2/PUSH 100-240V												
						BB 36V/max.350mA												
18V9	17.7	2700	90	1391-1615	S2 20°	OU ON-OFF 100-240V												
18W9	17.7	3000	90	1391-1615	M2 33°	TS PHASE CUT 220-240V												
18X9	17.7	4000	90	1391-1615	F1 47°	DS DALI-2/PUSH 100-240V												
						BB 36V/max.500mA												
AAG1	GU10	Max. 8W				NA	BU 220-240V											

 **Play Emergency**
P. 950

Play Deco
Symmetrical Trimless

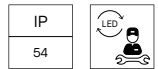

Code example / Exemple d'élaboration d'une référence: **AG24-P7V9S10UWP**

Model		W	K	CRI	Lm	Optics	Source	Finishes								
<p>AG24 - Round Fixed Trimless 0-21 mm 75</p> <p>W X (mm)</p> <table border="1"> <tr><td>7</td><td>95</td></tr> <tr><td>13</td><td>115</td></tr> <tr><td>18</td><td>135</td></tr> <tr><td>GU10</td><td>85</td></tr> </table>	7	95	13	115	18	135	GU10	85	P7V9	6.4	2700	90	514-575	S2 15° OU	ON-OFF 100-240V	WP
	7	95														
	13	115														
	18	135														
	GU10	85														
	P7W9	6.4	3000	90	596-666	M2 28° TS	PHASE CUT 220-240V	WS								
	P7X9	6.4	4000	90	596-666	F1 49° DS	DALI-2/PUSH 100-240V	WQ								
							BB									
	P7V9	8.5	2700	90	499	S1 8° OU	ON-OFF 100-240V									
	P7W9	8.5	3000	90	537	TS	PHASE CUT 220-240V									
	P7X9	8.5	4000	90	575	DS	DALI-2/PUSH 100-240V									
							BB									
<p>AG28 - Square Fixed Trimless 0-21 mm 75</p> <p>W X (mm)</p> <table border="1"> <tr><td>7</td><td>95</td></tr> <tr><td>13</td><td>115</td></tr> <tr><td>18</td><td>135</td></tr> <tr><td>GU10</td><td>80</td></tr> </table>	7	95	13	115	18	135	GU10	80	13V9	11.9	2700	90	1048-1237	S2 20° OU	ON-OFF 100-240V	
	7	95														
	13	115														
	18	135														
	GU10	80														
	13W9	11.9	3000	90	1128-1331	M2 33° TS	PHASE CUT 220-240V									
	13X9	11.9	4000	90	1207-1424	F1 44° DS	DALI-2/PUSH 100-240V									
						BB										
18V9	17.7	2700	90	1359-1598	S2 20° OU	ON-OFF 100-240V										
18W9	17.7	3000	90	1463-1720	M2 33° TS	PHASE CUT 220-240V										
18X9	17.7	4000	90	1566-1840	F1 47° DS	DALI-2/PUSH 100-240V										
						BB										
AAG1	GU10	Max. 8W				NA BU	220-240V									

Play Emergency
 P. 950

Play

Deco Asymmetrical

BODY MAT
PC,AL

Play Deco Asymmetrical Trim

IP
54

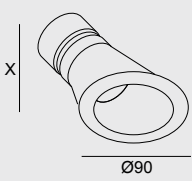
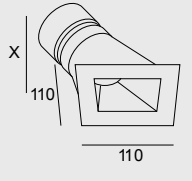

Code example / Exemple d'élaboration d'une référence: **AG25-P7V9S10UWR**

Model		W	K	CRI	Lm	Optics	Source	Finishes										
 <p>AG25 - Round Fixed 0-25 mm 80</p> <table border="1"> <tr><th>W</th><th>X (mm)</th></tr> <tr><td>7</td><td>95</td></tr> <tr><td>13</td><td>115</td></tr> <tr><td>18</td><td>135</td></tr> <tr><td>GU10</td><td>85</td></tr> </table>	W	X (mm)	7	95	13	115	18	135	GU10	85	P7V9	6.4	2700	90	455-583	S2 15°	OU ON-OFF 100-240V	WG
	W	X (mm)																
	7	95																
	13	115																
	18	135																
	GU10	85																
	P7W9	6.4	3000	90	537-631	M2 28°	TS PHASE CUT 220-240V	WH										
	P7X9	6.4	4000	90	527-631	F1 49°	DS DALI-2/PUSH 100-240V	WI										
							BB 9V/max.700mA	WJ										
P7V9	8.5	2700	90	385	S1 8°	OU ON-OFF 100-240V	WK											
P7W9	8.5	3000	90	414		TS PHASE CUT 220-240V	WL											
P7X9	8.5	4000	90	443		DS DALI-2/PUSH 100-240V	WM											
						BB 12V/max.700mA	WN											
 <p>AG29 - Square Fixed 0-25 mm 100</p> <table border="1"> <tr><th>W</th><th>X (mm)</th></tr> <tr><td>7</td><td>90</td></tr> <tr><td>13</td><td>110</td></tr> <tr><td>18</td><td>130</td></tr> <tr><td>GU10</td><td>80</td></tr> </table>	W	X (mm)	7	90	13	110	18	130	GU10	80	13V9	11.9	2700	90	578-881	S2 20°	OU ON-OFF 100-240V	WR
	W	X (mm)																
	7	90																
	13	110																
	18	130																
	GU10	80																
	13W9	11.9	3000	90	992-1331	M2 33°	TS PHASE CUT 220-240V											
	13X9	11.9	4000	90	1061-1424	F1 44°	DS DALI-2/PUSH 100-240V											
							BB 36V/max.350mA											
18V9	17.7	2700	90	1378-1554	S2 20°	OU ON-OFF 100-240V												
18W9	17.7	3000	90	1378-1554	M2 33°	TS PHASE CUT 220-240V												
18X9	17.7	4000	90	1378-1554	F1 47°	DS DALI-2/PUSH 100-240V												
						BB 36V/max.500mA												
AAG1	GU10	Max. 8W				NA	BU 220-240V											

 **Play Emergency**
P. 951

Play Deco
Asymmetrical Trimless

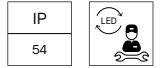

Code example / Exemple d'élaboration d'une référence: **AG26-P7V9S10UWP**

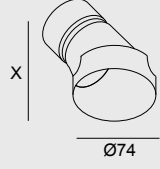
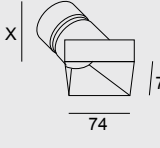
Model		W	K	CRI	Lm	Optics	Source	Finishes										
 <p>AG26 - Round Fixed Trimless</p> <p>0-21 mm 75</p> <table border="1"> <tr><th>W</th><th>X (mm)</th></tr> <tr><td>7</td><td>95</td></tr> <tr><td>13</td><td>115</td></tr> <tr><td>18</td><td>135</td></tr> <tr><td>GU10</td><td>85</td></tr> </table>	W	X (mm)	7	95	13	115	18	135	GU10	85	P7V9	6.4	2700	90	455-544	S2 15°	OU ON-OFF 100-240V	WP
	W	X (mm)																
	7	95																
	13	115																
	18	135																
	GU10	85																
	P7W9	6.4	3000	90	527-631	M2 28°	TS PHASE CUT 220-240V	WS										
	P7X9	6.4	4000	90	527-631	F1 49°	DS DALI-2/PUSH 100-240V	WQ										
							BB 9V/max.700mA											
P7V9	8.5	2700	90	385	S1 57°	OU ON-OFF 100-240V												
P7W9	8.5	3000	90	414	TS PHASE CUT 220-240V													
P7X9	8.5	4000	90	443	DS DALI-2/PUSH 100-240V													
						BB 12V/max.700mA												
 <p>AG31 - Square Fixed Trimless</p> <p>0-21 mm 75</p> <table border="1"> <tr><th>W</th><th>X (mm)</th></tr> <tr><td>7</td><td>95</td></tr> <tr><td>13</td><td>115</td></tr> <tr><td>18</td><td>135</td></tr> <tr><td>GU10</td><td>80</td></tr> </table>	W	X (mm)	7	95	13	115	18	135	GU10	80	13V9	11.9	2700	90	922-1162	S2 20°	OU ON-OFF 100-240V	
	W	X (mm)																
	7	95																
	13	115																
	18	135																
	GU10	80																
	13W9	11.9	3000	90	992-1250	M2 33°	TS PHASE CUT 220-240V											
	13X9	11.9	4000	90	1061-1338	F1 44°	DS DALI-2/PUSH 100-240V											
							BB 36V/max.350mA											
18V9	17.7	2700	90	1188-149	S2 20°	OU ON-OFF 100-240V												
18W9	17.7	3000	90	1279-1609	M2 33°	TS PHASE CUT 220-240V												
18X9	17.7	4000	90	1369-1722	F1 47°	DS DALI-2/PUSH 100-240V												
						BB 36V/max.500mA												
AAG1	GU10	Max. 8W				NA BU 220-240V												

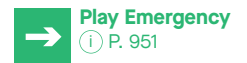

Play Emergency
P. 951

Play Deco Double











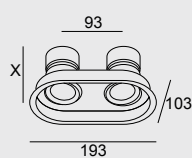









BODY MAT
PC,AL







Play Deco Double



IP
54





Code example / Exemple d'élaboration d'une référence: **AG42-P7V9S10U14**

Model	W	K	CRI	Lm	Optics	Source	Finishes										
 <p>AG42 - Round Adjustable 2x 95x93 IP54 ±20° 320°</p> <table border="1"> <tr><th>w</th><th>X (mm)</th></tr> <tr><td>7</td><td>95</td></tr> <tr><td>13</td><td>115</td></tr> <tr><td>18</td><td>135</td></tr> <tr><td>GU10</td><td>85</td></tr> </table>	w	X (mm)	7	95	13	115	18	135	GU10	85	P7V9	2x6.4	2700	90	1028-1142	S2 15° OU  ON-OFF 100-240V	14 
	w	X (mm)															
	7	95															
	13	115															
	18	135															
	GU10	85															
	P7W9	2x6.4	3000	90	1191-1324	M2 28° TS  PHASE CUT 220-240V	23 										
	P7X9	2x6.4	4000	90	1191-1324	F1 49° DS  DALI-2/PUSH 100-240V BB  9V/max.700mA	60 										
	P7V9	2x8.5	2700	90	499	S1 8° OU  ON-OFF 100-240V											
	P7W9	2x8.5	3000	90	537	TS  PHASE CUT 220-240V											
	P7X9	2x8.5	4000	90	575	DS  DALI-2/PUSH 100-240V BB  12V/max.700mA											
	13V9	2x11.9	2700	90	2096-2443	S2 20° OU  ON-OFF 100-240V											
	13W9	2x11.9	3000	90	2256-2630	M2 33° TS  PHASE CUT 220-240V											
	13X9	2x11.9	4000	90	2414-2814	F1 44° DS  DALI-2/PUSH 100-240V BB  36V/max.350mA											
	18V9	2x17.7	2700	90	2724-3192	S2 20° OU  ON-OFF 100-240V											
18W9	2x17.7	3000	90	2782-3436	M2 33° TS  PHASE CUT 220-240V												
18X9	2x17.7	4000	90	2782-3436	F1 47° DS  DALI-2/PUSH 100-240V BB  36V/max.500mA												
AAG1	2x GU10	Max. 8W			NA BU  220-240V												

		Play Mini		Play			
		Play Mini 2W	Play Mini 3W	Play 7W	Play 13W	Play 18W	Play GU10
Lens accessories Accessoires optiques							
	Elliptical diffuser (5u.) Diffuseur elliptique (5 u.)	71-7891-00-00	71-7891-00-00	71-5167-00-00	71-5167-00-00	71-5167-00-00	71-5167-00-00
	Square diffuser (5u.) Diffuseur carré (5 u.)	-	-	71-5658-00-00	71-5658-00-00	71-5658-00-00	71-5658-00-00
	Halo fader (5u.) Diffuseur de halo (5 u.)	71-7893-00-00	71-7893-00-00	71-6099-00-00	71-6099-00-00	71-6099-00-00	71-6099-00-00
	Honeycomb panel (5u.) Grille en nid d'abeille (5 u.)	71-7892-00-00	71-7892-00-00	71-5166-60-00	71-5166-60-00	71-5166-60-00	71-5166-60-00
	Screen (5u.) Diffuseur (5 u.)	71-7894-60-00	71-7894-60-00	71-7895-60-00	71-7895-60-00	71-7895-60-00	71-7895-60-00
	Visual comfort (1u.) Confort visuel (1 u.)	14 ○ -	-	71-4754-14-00	71-4754-14-00	71-4754-14-00	71-4754-14-00
		60 ● -	-	71-4754-60-00	71-4754-60-00	71-4754-60-00	71-4754-60-00

Fixing accessories Accessoires de fixation							
	Kit to recess in concrete for Ø36 Kit d'encastrement béton pour Ø36	71-5617-60-00	71-5617-60-00	-	-	-	-
	Kit to recess in concrete for Ø40-42 Kit d'encastrement béton pour Ø40-42	71-5618-60-00	71-5618-60-00	-	-	-	-

Drivers							
Driver P.984							
	ON-OFF IP20	71-B406-00-00	71-7699-00-00	-	-	-	-
		Min.1 - Max.9	Min.1 - Max.4				
		-	71-3542-00-00 ⚡	-	-	-	-
			Min.1 - Max.8				
	PHASE CUT 240V IP20	71-4898-00-00 ⚡	71-4898-00-00 ⚡	-	-	-	-
		Min.1 - Max.15	Min.1 - Max.5				
	DALI2 IP20	71-A192-00-00 ⚡	71-A191-00-00 ⚡	-	-	-	-
		Min.4 - Max.14	Min.3 - Max.5				

Lite

Essential
SOLUTION

Designed by LedsC4 Architectural



+ Lite



Lite is a recessed downlight with three sizes (Ø75, Ø88 and Ø105), which, thanks to its included extra bezel, covers all recess diameters from Ø65 to Ø110 mm. It is available in two frames, Deep, maximising comfort, and Flat, with a height of only 40 mm, facilitating installation in especially low ceilings. With both fixed and adjustable options, it allows you to find the ideal solution for each space.

Disponible en trois tailles (Ø75, Ø88 et Ø105), Lite est un downlight encastré qui permet de couvrir tous les diamètres d'encastrement, de Ø65 à Ø110 mm, grâce à la bague supplémentaire incluse. Proposé avec deux cadres, Deep, qui maximise le confort, et Flat, de seulement 40 mm de haut, il facilite l'installation sur les plafonds particulièrement bas. Grâce aux deux options, fixe et réglable, il permet de trouver la solution idéale pour chaque espace.



Fixed
Fixe

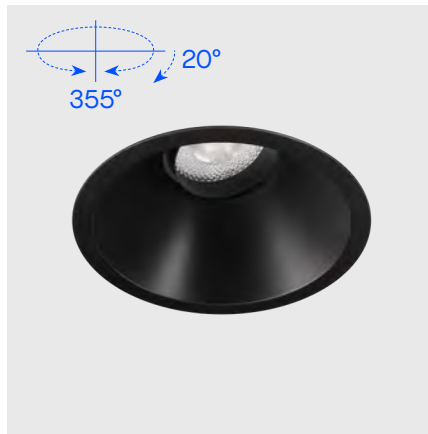

Adjustable
Réglable

The new adjustable frames maintain the same design and add extra functionality, enabling users to freely direct the light beam with a rotation of 355° and a tilt of 20°.

Les nouveaux cadres réglables conservent le même design et offrent une fonctionnalité supplémentaire, permettant d'orienter librement le faisceau lumineux grâce à une rotation de 355° et à une inclinaison de 20°.

Lite Deep Fixe

226

Ø 70mm



Lite Deep Adjustable

227

Ø 75mm



Lite Flat Fixe

228

Ø 70mm



Flat Adjustable

228

Ø 80mm



Ø 88mm



Ø 105mm



8.5 - 14W



34°

○ ●
14 60



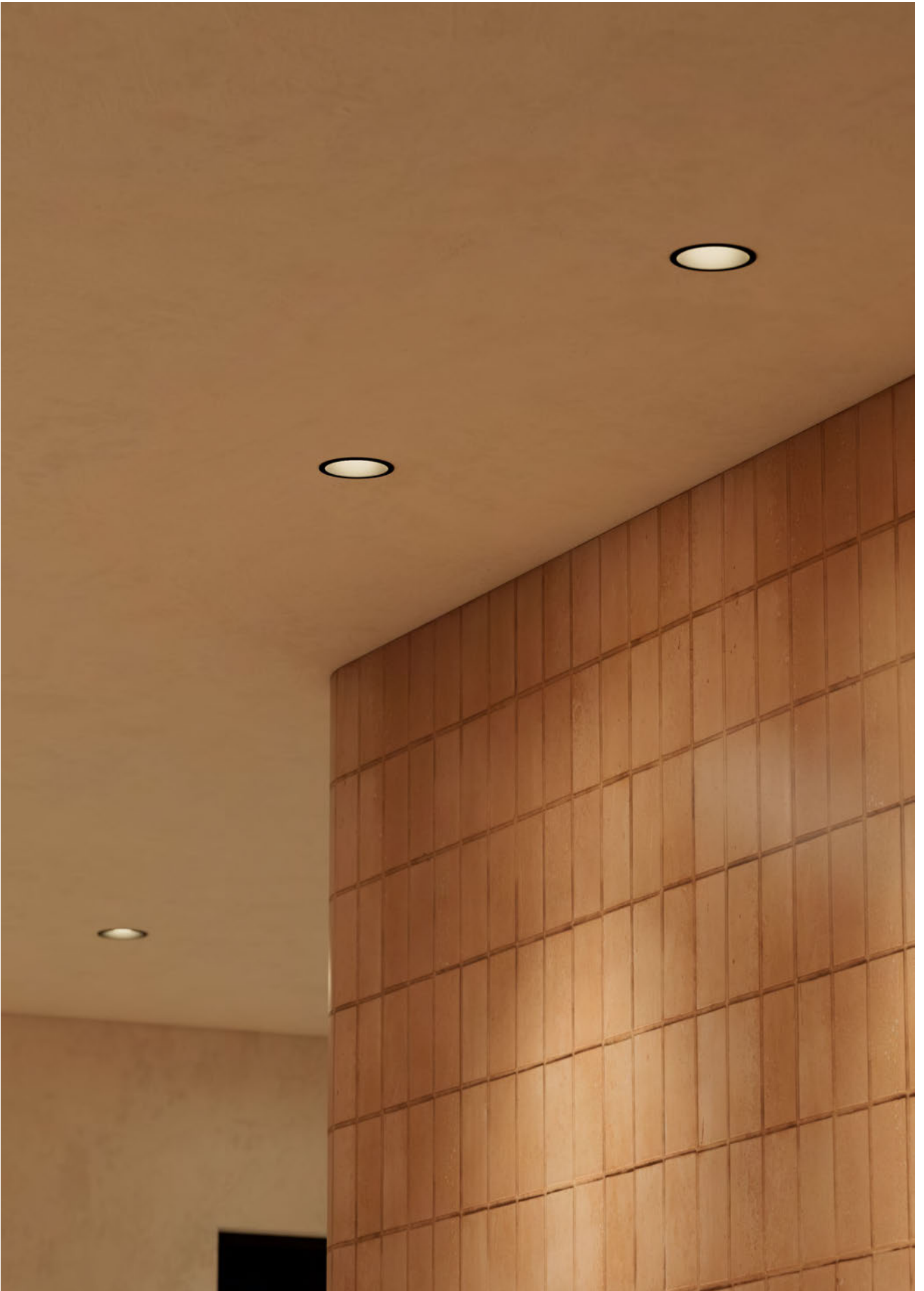

With an output of up to 1150 lm, the new 12.3 W module enables you to tackle the most challenging projects, with the possibility of both PHASE CUT and DALI dimming.
Doté d'une charge de 1 150 lm, le nouveau module de 12,3 W permet de répondre aux besoins des projets les plus exigeants, avec la possibilité de réglage tant par COUPURE DE PHASE que via DALI.

Extra easy-installation bezel Bague supplémentaire pour une installation facile

With its three sizes (Ø75, 88 and 105), and the included optional extra bezel, Lite can cover all recess diameters from 65 to 110 mm.

Avec ses trois tailles (Ø75, 88 et 105) et à la bague supplémentaire incluse en option, Lite permet de couvrir tous les diamètres d'encastrement, de 65 à 110 mm.

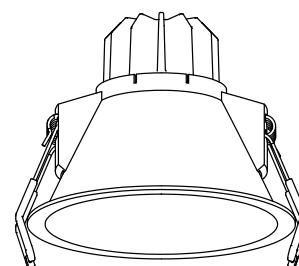
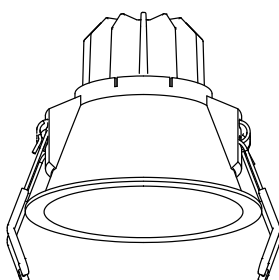
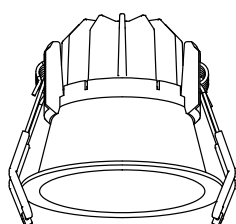

Ⓜ Ø65-79 mm

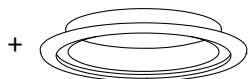

Ⓜ Ø80-94 mm



Ⓜ Ø95-110 mm

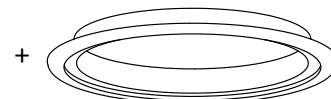

Small
Ø 75-89 mm

Medium
Ø 88-102 mm

Large
Ø 105-119 mm

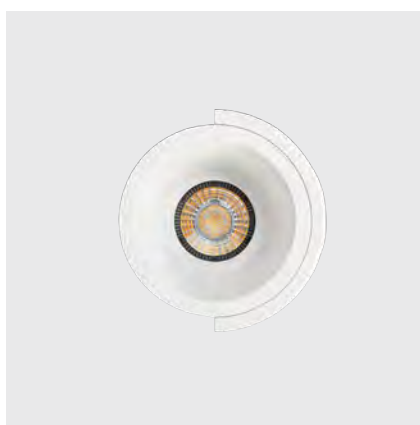
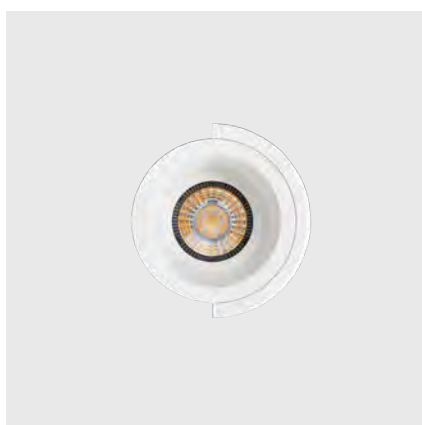

High visual comfort Grand confort visuel

Using a planar lens and an elevated position relative to the ceiling plane, Lite manages to reduce glare levels below $UGR < 19$, enhancing the comfort of the spaces where it is installed.
Grâce à l'utilisation d'une lentille planaire et à une position surélevée par rapport au plafond, Lite parvient à réduire les niveaux d'éblouissement en dessous d'un facteur $UGR < 19$, ce qui accentue le confort des espaces où il est installé.

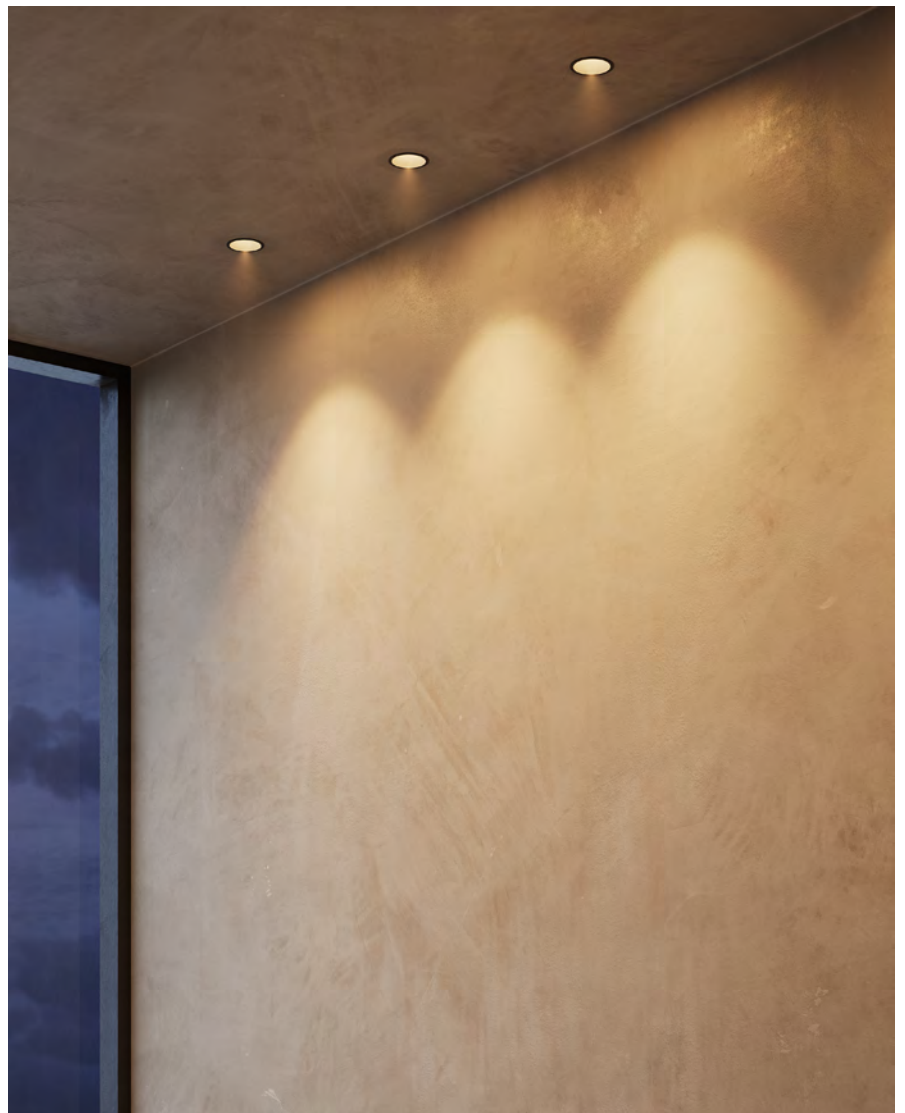

INDOOR

DOWNLIGHTS

Accessories to modulate the light Accessoires pour moduler la lumière

As an option, Lite offers up to five accessories that sculpt the light and achieve the optimal result in each environment.

En option, Lite propose jusqu'à cinq accessoires qui permettent de moduler la lumière et d'obtenir ainsi un résultat optimal dans chaque environnement.

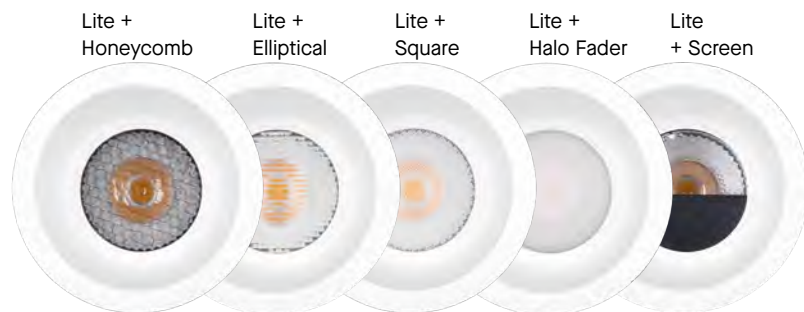

Lite Deep

IP	BODY MAT	DIF MAT		3	50000h			
54	PC,AL	PC		MacAdam	L80 B20			

Lite Deep Fix Ø70

UGR
<16

○ ●
14 60



8.5W=69
13.9W=89

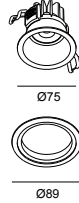

⌀ 65-79 0-18 mm

LED									
K	CRI	W Total	Real Lm	Optics	Code				
2700	90	8.5	639	34°	90-A026	14	00	ON-OFF 100-240V	
2700	90	13.9	1016	34°	90-A174	60	- TS	PHASE CUT 220-240V	
							DS	DALI-2/PUSH 220-240V	
3000	90	8.5	667	34°	90-A027	14	00	ON-OFF 100-240V	
3000	90	13.9	1059	34°	90-A175	60	- TS	PHASE CUT 220-240V	
							DS	DALI-2/PUSH 220-240V	
4000	90	8.5	721	34°	90-A028	14	00	ON-OFF 100-240V	
4000	90	13.9	1147	34°	90-A176	60	- TS	PHASE CUT 220-240V	
							DS	DALI-2/PUSH 220-240V	

Lite Deep Fix Ø88

UGR
<16

○ ●
14 60



8.5W=78
13.9W=89



⌀ 80-94 0-18 mm

LED									
K	CRI	W Total	Real Lm	Optics	Code				
2700	90	8.5	635	33°	90-8078	14	00	ON-OFF 100-240V	
2700	90	13.9	1025	33°	90-A177	60	- TS	PHASE CUT 220-240V	
							DS	DALI-2/PUSH 220-240V	
3000	90	8.5	662	33°	90-8079	14	00	ON-OFF 100-240V	
3000	90	13.9	1069	33°	90-A178	60	- TS	PHASE CUT 220-240V	
							DS	DALI-2/PUSH 220-240V	
4000	90	8.5	716	33°	90-8080	14	00	ON-OFF 100-240V	
4000	90	13.9	1158	33°	90-A179	60	- TS	PHASE CUT 220-240V	
							DS	DALI-2/PUSH 220-240V	

Lite Deep Fix Ø105

UGR
<13

○ ●
14 60



8.5W=86
13.9W=106

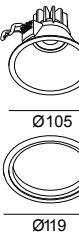

⌀ 95-110 0-18 mm

LED									
K	CRI	W Total	Real Lm	Optics	Code				
2700	90	8.5	636	34°	90-A029	14	00	ON-OFF 100-240V	
2700	90	13.9	1023	34°	90-A180	60	- TS	PHASE CUT 220-240V	
							DS	DALI-2/PUSH 220-240V	
3000	90	8.5	663	34°	90-A030	14	00	ON-OFF 100-240V	
3000	90	13.9	1067	34°	90-A181	60	- TS	PHASE CUT 220-240V	
							DS	DALI-2/PUSH 220-240V	
4000	90	8.5	718	34°	90-A031	14	00	ON-OFF 100-240V	
4000	90	13.9	1155	34°	90-A182	60	- TS	PHASE CUT 220-240V	
							DS	DALI-2/PUSH 220-240V	

Lite Deep Adjustable
Ø75

UGR	
<16	20°



8.5W=72
13.9W=92

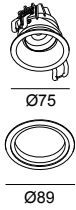

65-79 0-18 mm

LED									
K	CRI	W Total	Real Lm	Optics	Code				
2700	90	8.5	639	34°	90-A183	14	00	ON-OFF	220-240V
2700	90	13.9	1016	34°	90-A186	60	- TS	PHASE CUT	220-240V
							DS	DALI-2/PUSH	220-240V
3000	90	8.5	667	34°	90-A184	14	00	ON-OFF	220-240V
3000	90	13.9	1059	34°	90-A187	60	- TS	PHASE CUT	220-240V
							DS	DALI-2/PUSH	220-240V
4000	90	8.5	721	34°	90-A185	14	00	ON-OFF	220-240V
4000	90	13.9	1147	34°	90-A188	60	- TS	PHASE CUT	220-240V
							DS	DALI-2/PUSH	220-240V

14 60

INDOOR

Lite Deep Adjustable
Ø88

UGR		
<16	20°	355



8.5W=82
13.9W=102

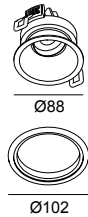

80-94 0-18 mm

LED									
K	CRI	W Total	Real Lm	Optics	Code				
2700	90	8.5	635	33°	90-A189	14	00	ON-OFF	220-240V
2700	90	13.9	1025	33°	90-A192	60	- TS	PHASE CUT	220-240V
							DS	DALI-2/PUSH	220-240V
3000	90	8.5	662	33°	90-A190	14	00	ON-OFF	220-240V
3000	90	13.9	1069	33°	90-A193	60	- TS	PHASE CUT	220-240V
							DS	DALI-2/PUSH	220-240V
4000	90	8.5	716	33°	90-A191	14	00	ON-OFF	220-240V
4000	90	13.9	1158	33°	90-A194	60	- TS	PHASE CUT	220-240V
							DS	DALI-2/PUSH	220-240V

14 60

DOWNLIGHTS

Lite Deep Adjustable
Ø105

UGR		
<13	355°	20°



8.5W=Max.90
13.9W=Max.110

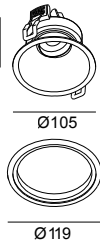

95-110 0-18 mm

LED									
K	CRI	W Total	Real Lm	Optics	Code				
2700	90	8.5	636	34°	90-A195	14	00	ON-OFF	220-240V
2700	90	13.9	1023	34°	90-A198	60	- TS	PHASE CUT	220-240V
							DS	DALI-2/PUSH	220-240V
3000	90	8.5	663	34°	90-A196	14	00	ON-OFF	220-240V
3000	90	13.9	1067	34°	90-A199	60	- TS	PHASE CUT	220-240V
							DS	DALI-2/PUSH	220-240V
4000	90	8.5	718	34°	90-A197	14	00	ON-OFF	220-240V
4000	90	13.9	1155	34°	90-A200	60	- TS	PHASE CUT	220-240V
							DS	DALI-2/PUSH	220-240V

14 60

Lite Flat

IP	BODY MAT	DIF MAT		3		
54	PC,AL	PC		MacAdam		

Lite Flat Fix Ø70

○ ●
14 60

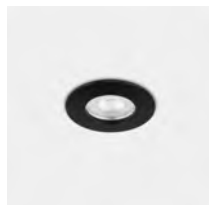

8.5W=40
13.9W=60

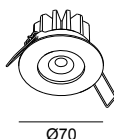

60-68 0-10 mm

LED									
K	CRI	W Total	Real Lm	Optics	Code				
2700	90	8.5	651	34°	90-A201	14	00	ON-OFF 220-240V	
2700	90	13.9	954	34°	90-A204	60	- TS	PHASE CUT 220-240V	
							DS	DALI-2/PUSH 220-240V	
3000	90	8.5	679	34°	90-A202	14	00	ON-OFF 220-240V	
3000	90	13.9	1010	34°	90-A205	60	- TS	PHASE CUT 220-240V	
							DS	DALI-2/PUSH 220-240V	
4000	90	8.5	734	34°	90-A203	14	00	ON-OFF 220-240V	
4000	90	13.9	1093	34°	90-A206	60	- TS	PHASE CUT 220-240V	
							DS	DALI-2/PUSH 220-240V	

Lite Flat Adjustable Ø80

○ ●
14 60

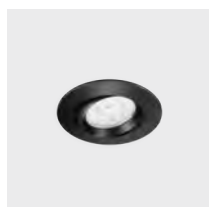

8.5W=45
13.9W=65



65-78 0-15 mm

LED									
K	CRI	W Total	Real Lm	Optics	Code				
2700	90	8.5	651	34°	90-A207	14	00	ON-OFF 220-240V	
2700	90	13.9	954	34°	90-A210	60	- TS	PHASE CUT 220-240V	
							DS	DALI-2/PUSH 220-240V	
3000	90	8.5	679	34°	90-A208	14	00	ON-OFF 220-240V	
3000	90	13.9	1010	34°	90-A211	60	- TS	PHASE CUT 220-240V	
							DS	DALI-2/PUSH 220-240V	
4000	90	8.5	734	34°	90-A209	14	00	ON-OFF 220-240V	
4000	90	13.9	1093	34°	90-A212	60	- TS	PHASE CUT 220-240V	
							DS	DALI-2/PUSH 220-240V	

Lens accessories

Accessoires optiques

Lite Deep

Lite Flat

	Elliptical diffuser (5u.) Diffuseur elliptique (5 u.)							71-5167-00-00	71-5167-00-00
	Square diffuser (5u.) Diffuseur carré (5 u.)							71-5658-00-00	71-5658-00-00
	Halo fader (5u.) Diffuseur de halo (5 u.)							71-6099-00-00	71-6099-00-00
	Visual comfort (1u.) Confort visuel (1 u.)	14	○					71-4754-14-00	71-4754-14-00
		60	●					71-4754-60-00	71-4754-60-00
	Honeycomb panel (5u.) Grille en nid d'abeille (5 u.)							71-5166-60-00	71-5166-60-00
	Screen (5u.) Diffuseur (5 u.)							71-7895-60-00	71-7895-60-00

Fixing accessories

Accessoires de fixation

	Extra bezel to adapt to different diameters Biseautage supplémentaire permettant de s'adapter aux différents diamètres	Included	-
--	---------------------------------------------------------------------------------------------------------------------------	----------	---

Dome

Essential
SOLUTION

INDOOR



Downlight with GU10 light bulb to adapt functionally and effectively to every need.
Downlight avec ampoule GU10 pour s'adapter de manière fonctionnelle et efficace à chaque besoin.

DOWNLIGHTS

Dome Ø90

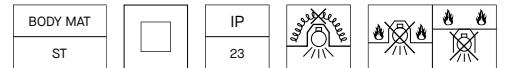

○ ●
14 60

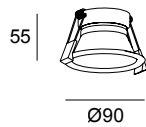
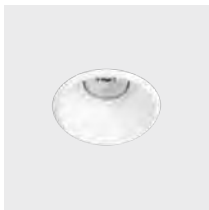

GU10

W	Code
Max. 8	DN-1600 - 14 - 60 - 00

Ⓜ 82 Ⓜ 0-25 mm

Dome Ø120

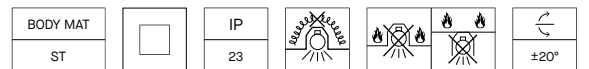

○ ●
14 60

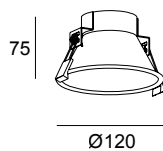
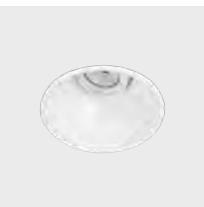

GU10

W	Code
Max. 8	DN-1601 - 14 - 60 - 00

Ⓜ 112 Ⓜ 0-25 mm

Fixing accessories Accessoires de fixation



Invisible ring for LED bulb
Anneau invisible pour ampoule LED

Included

Ges Recessed

Essential
SOLUTION

Ceiling
P. 282



Recessed and surface-mounted downlights made of plaster to fully integrate the luminaire into the space.

Downlights encastrés fabriqués en plâtre pour faciliter l'intégration totale du luminaire dans l'espace.

Easy integration in plasterboard
Intégration facile sur placoplâtre

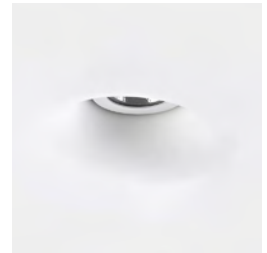
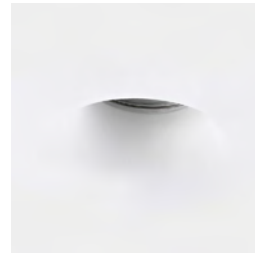

Step-by-step installation. We recommend you use a flexible sealant to prevent possible fissures and/or the accumulation of dirt.

Installation étape par étape. L'utilisation d'un mastic d'étanchéité souple est recommandée pour éviter d'éventuelles fissures et/ou l'accumulation d'impuretés.

Ges Recessed Round Fix

IP
23

BODY MAT
PLSTER



○
14

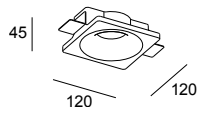

GU10	
W	Code
Max. 8	90-2902 - 14 - 00

125×125 9-15 mm

Ges Recessed Round Adjustable

IP
23

BODY MAT
PLSTER



○
14

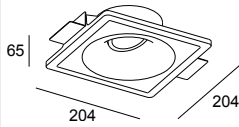

GU10	
W	Code
Max. 8	90-2903- 14 - 00

210×210 9-15 mm

Ges Recessed Round Fix Deep

IP
23

BODY MAT
PLSTER



○
14

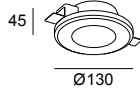

GU10	
W	Code
Max. 8	90-1720 - 14 - 00

135 0-12 mm

Ges Recessed Square Fix

IP
23

BODY MAT
PLSTER



○
14

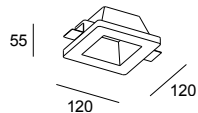

GU10	
W	Code
Max. 8	90-1722 - 14 - 00

125×125 0-12 mm

INDOOR

DOWNLIGHTS

Bento

Designed by LedsC4 Architectural



+ Bento

Low Voltage
P. 126

Ceiling
P. 309

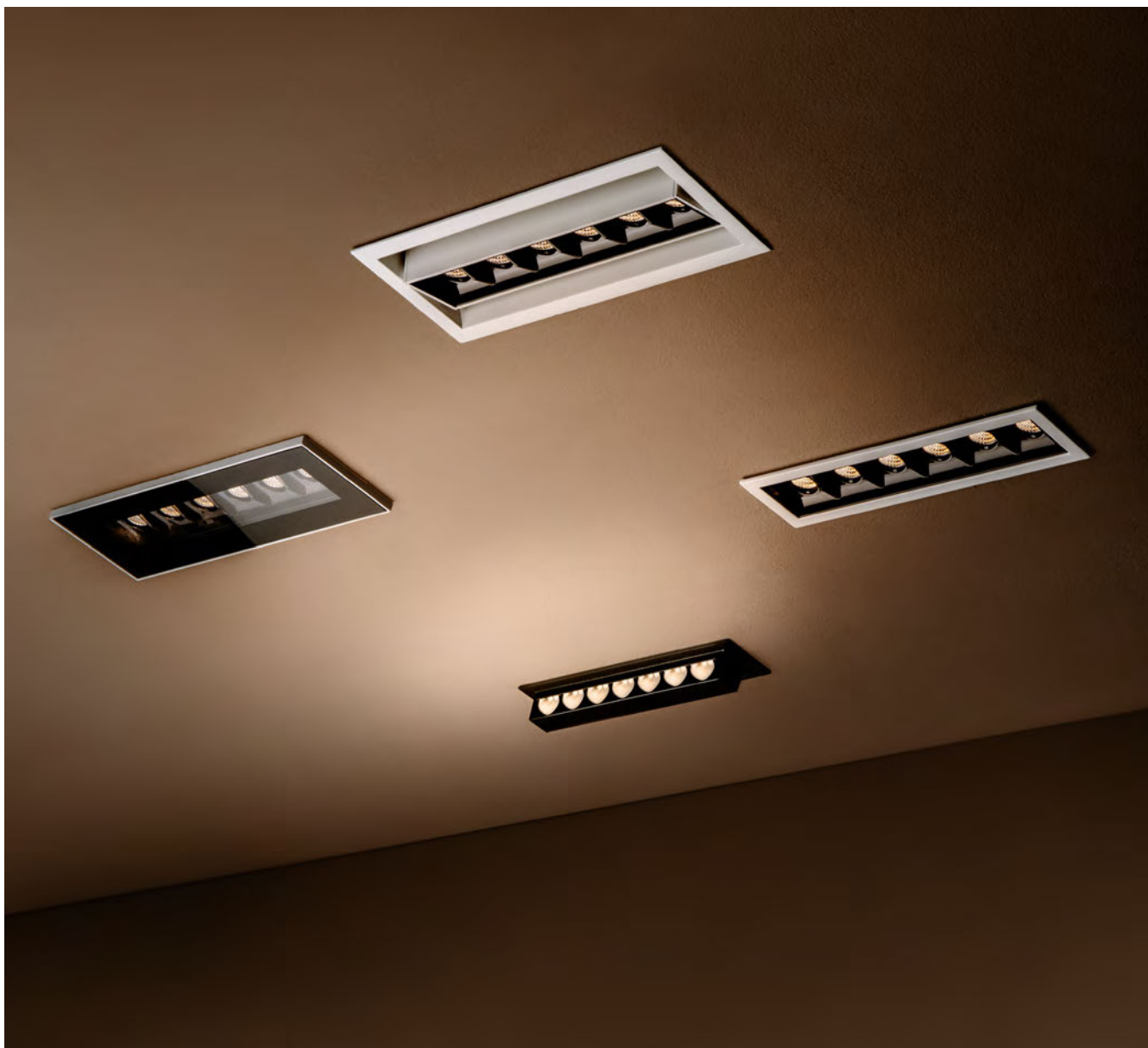
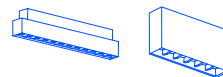

Lens system designed with high-definition micro-reflectors that conceal the light source Système optique conçu avec des micro-réflecteurs haute définition qui masquent la source lumineuse

The lenses in this collection of downlights are specially developed to avoid glares and achieve optimal control of the luminaire in demanding situations. Featuring a multi-cell structure and individual lens modules, Bento is the ideal choice for environments where comfort and integration are the foremost concern.

Le groupe optique de cette collection de downlights est spécialement conçu pour éviter l'éblouissement et obtenir un contrôle optimal du luminaire dans les situations exigeantes. Avec sa structure multicellulaire et ses modules optiques individuels, Bento est l'option idéale pour les environnements qui nécessitent un maximum de confort et d'intégration.



With sizes from 3 to 12 LEDs, rectangular or square, the structure with individual optical modules of Bento Standard is developed to ensure maximum comfort with a Dark Light effect.

Avec des tailles de 3 à 12 LED, de forme rectangulaire ou carrée, la structure à modules optiques individuels de Bento Standard est conçue pour garantir un confort maximal avec effet Dark Light (lumière sombre).

High-definition micro-reflectors Microréflecteurs de haute résolution

Bento's lens system is the result of a painstaking development project. The high-definition micro-reflectors, integrated into the innovative black or white anti-glare diffuser, achieve a UGR of <math><16</math> and conceal the light source to achieve excellent visual comfort.

Le système optique de Bento est le fruit d'un projet de développement minutieux. Intégrés dans l'innovant diffuseur anti-éblouissement noir ou blanc, les micro-réflecteurs haute définition permettent d'obtenir un UGR <math><16</math> et de dissimuler la source lumineuse, garantissant ainsi un excellent confort visuel.



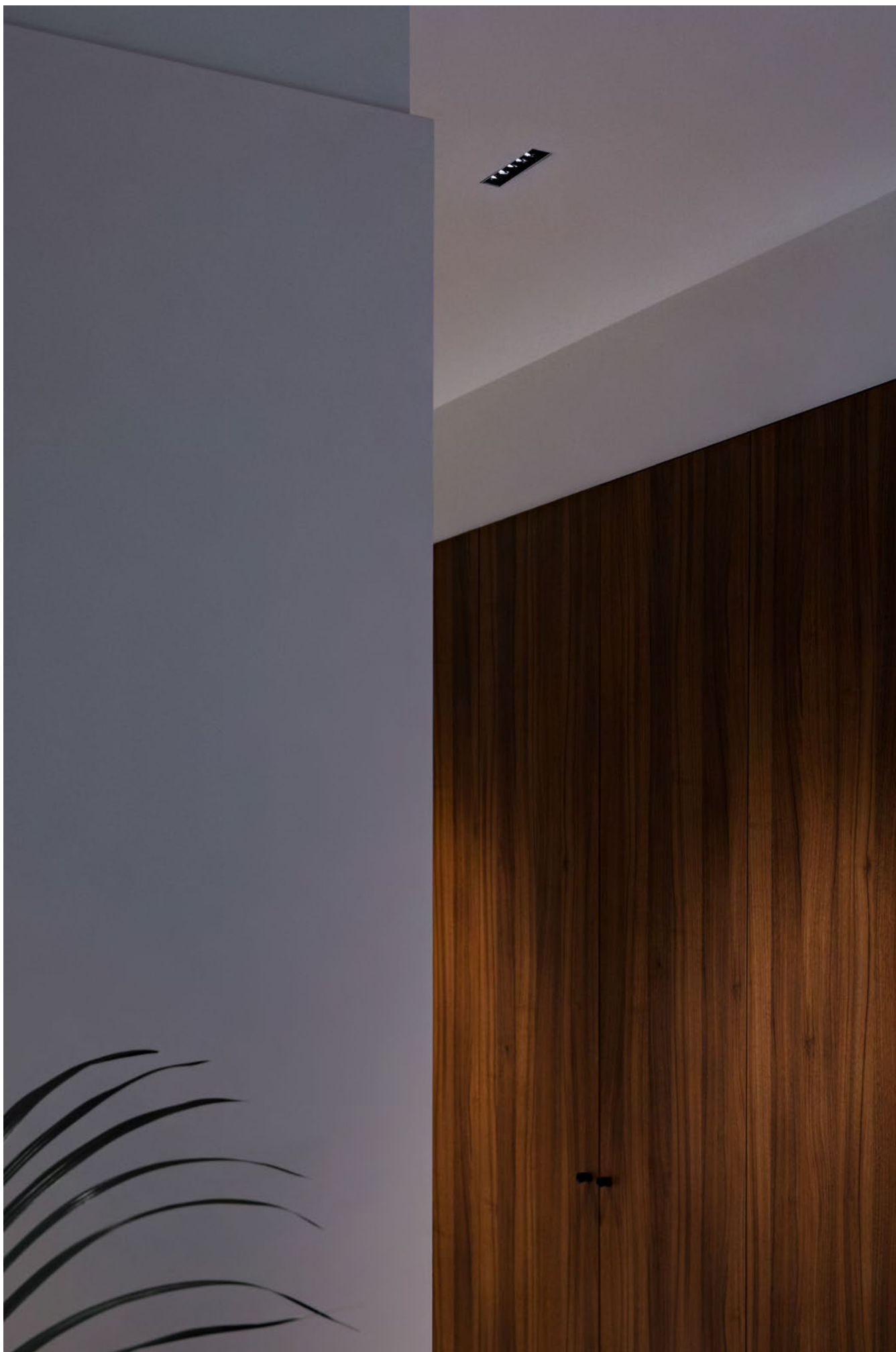

Bento Standard in Taulat Offices project, 19-21. Architecture: aaa Barcelona by Ignacio Infiesta. Photography: Javier Márquez.

Bento Standard dans le cadre du projet des bureaux Taulat, 19-21. Architecture : aaa Barcelona par Ignacio Infiesta. Photographie : Javier Márquez.

Bento 3 LEDS Trim

BODY MAT	3	IP	UGR		WELL		
AL	MacAdam	23	<13				

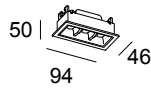

40x89 0-18 mm

LED						max.700mA 9V	
K	CRI	W	Real Lm	Optics	Code		
2700	90	6.1	560	17°	90-6364	14	14
2700	90	6.1	638	38°	90-6366	60	60
2700	90	6.1	603	47°	90-6368		
3000	90	6.1	560	17°	90-6365	14	14
3000	90	6.1	638	38°	90-6367	60	60
3000	90	6.1	603	47°	90-6369		
4000	90	6.1	609	17°	90-6673	14	14
4000	90	6.1	693	38°	90-6674	60	60
4000	90	6.1	655	47°	90-6675		

Bento 3 LEDS Trimless

BODY MAT	3	IP	UGR		WELL		
AL	MacAdam	23	<13				

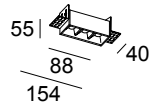

40x89 0-18 mm

LED						max.700mA 9V	
K	CRI	W	Real Lm	Optics	Code		
2700	90	6.1	560	17°	90-6161	14	14
2700	90	6.1	638	38°	90-6163	60	60
2700	90	6.1	603	47°	90-6165		
3000	90	6.1	560	17°	90-6162	14	14
3000	90	6.1	638	38°	90-6164	60	60
3000	90	6.1	603	47°	90-6166		
4000	90	6.1	609	17°	90-6676	14	14
4000	90	6.1	693	38°	90-6677	60	60
4000	90	6.1	655	47°	90-6678		

Bento 6 LEDS Trim

BODY MAT	3	IP	UGR		WELL		
AL	MacAdam	23	<13				

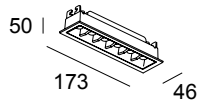

40x168 0-18 mm

LED						max.700mA 18V	
K	CRI	W	Real Lm	Optics	Code		
2700	90	12.2	1119	17°	90-6370	14	14
2700	90	12.2	1276	38°	90-6372	60	60
2700	90	12.2	1205	47°	90-6374		
3000	90	12.2	1119	17°	90-6371	14	14
3000	90	12.2	1276	38°	90-6373	60	60
3000	90	12.2	1205	47°	90-6375		
4000	90	12.2	1216	17°	90-6679	14	14
4000	90	12.2	1387	38°	90-6680	60	60
4000	90	12.2	1310	47°	90-6681		

Bento 6 LEDS Trimless

BODY MAT	3	IP	UGR		WELL			
AL	MacAdam	23	<13					

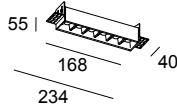

40x168 0-18 mm

LED						max.700mA 18V	
K	CRI	W	Real Lm	Optics	Code		
2700	90	12.2	1119	17°	90-6167	14	14
2700	90	12.2	1276	38°	90-6169	14	60
2700	90	12.2	1205	47°	90-6171		
3000	90	12.2	1119	17°	90-6168	14	14
3000	90	12.2	1276	38°	90-6170	14	60
3000	90	12.2	1205	47°	90-6172		
4000	90	12.2	1216	17°	90-6682	14	14
4000	90	12.2	1387	38°	90-6683	14	60
4000	90	12.2	1310	47°	90-6684		

Bento 12 LEDS Trim

BODY MAT	3	IP	UGR		WELL			
AL	MacAdam	23	<16					

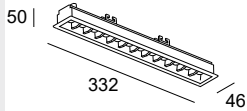

40x327 0-18 mm

LED						max.700mA 36V	
K	CRI	W	Real Lm	Optics	Code		
2700	90	24.4	2240	17°	90-6376	14	14
2700	90	24.4	2552	38°	90-6378	60	60
2700	90	24.4	2412	47°	90-6380		
3000	90	24.4	2240	17°	90-6377	14	14
3000	90	24.4	2552	38°	90-6379	60	60
3000	90	24.4	2412	47°	90-6381		
4000	90	24.4	2435	17°	90-6685	14	14
4000	90	24.4	2774	38°	90-6686	60	60
4000	90	24.4	2622	47°	90-6687		

Bento 12 LEDS Trimless

BODY MAT	3	IP	UGR		WELL			
AL	MacAdam	23	<16					

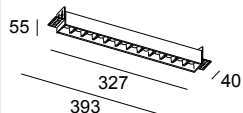

40x327 0-18 mm

LED						max.700mA 36V	
K	CRI	W	Real Lm	Optics	Code		
2700	90	24.4	2240	17°	90-6173	14	14
2700	90	24.4	2552	38°	90-6175	14	60
2700	90	24.4	2412	47°	90-6350		
3000	90	24.4	2240	17°	90-6174	14	14
3000	90	24.4	2552	38°	90-6349	14	60
3000	90	24.4	2412	47°	90-6351		
4000	90	24.4	2435	17°	90-6688	14	14
4000	90	24.4	2774	38°	90-6689	14	60
4000	90	24.4	2622	47°	90-6690		

Bento 18 LEDS Trim

BODY MAT	3	IP	UGR		WELL			
AL	MacAdam	23	<13					

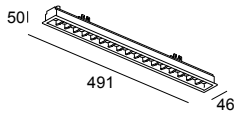

40x486 0-18 mm

LED							max.700mA 54V	
K	CRI	W	Real Lm	Optics	Code			
2700	90	36.5	3360	17°	90-6382	14 - 14		
2700	90	36.5	3828	38°	90-6384	60 - 60		
2700	90	36.5	3618	47°	90-6386			
3000	90	36.5	3360	17°	90-6383	14 - 14		
3000	90	36.5	3828	38°	90-6385	60 - 60		
3000	90	36.5	3618	47°	90-6387			
4000	90	36.5	3652	17°	90-6691	14 - 14		
4000	90	36.5	4161	38°	90-6692	60 - 60		
4000	90	36.5	3933	47°	90-6693			

Bento 18 LEDS Trimless

BODY MAT	3	IP	UGR		WELL			
AL	MacAdam	23	<13					

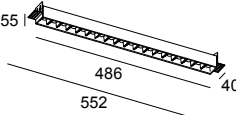

40x486 0-18 mm

LED							max.700mA 54V	
K	CRI	W	Real Lm	Optics	Code			
2700	90	36.5	3360	17°	90-6352	14 - 14		
2700	90	36.5	3828	38°	90-6354	14 - 60		
2700	90	36.5	3618	47°	90-6356	60 - 60		
3000	90	36.5	3360	17°	90-6353	14 - 14		
3000	90	36.5	3828	38°	90-6355	14 - 60		
3000	90	36.5	3618	47°	90-6357	60 - 60		
4000	90	36.5	3652	17°	90-6694	14 - 14		
4000	90	36.5	4161	38°	90-6695	14 - 60		
4000	90	36.5	3933	47°	90-6696	60 - 60		

Bento Square Trim

BODY MAT	3	IP	UGR		WELL			
AL	MacAdam	23	<13					

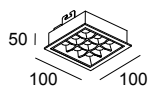

95x95 0-18 mm

LED							max.700mA 27V	
K	CRI	W	Real Lm	Optics	Code			
2700	90	18.3	1680	17°	90-6388	14 - 14		
2700	90	18.3	1914	38°	90-6390	60 - 60		
2700	90	18.3	1809	47°	90-6392			
3000	90	18.3	1680	17°	90-6389	14 - 14		
3000	90	18.3	1914	38°	90-6391	60 - 60		
3000	90	18.3	1809	47°	90-6393			
4000	90	18.3	1826	17°	90-6697	14 - 14		
4000	90	18.3	2080	38°	90-6698	60 - 60		
4000	90	18.3	1966	47°	90-6699			

Bento Square Trimless

BODY MAT	3	IP	UGR		50000h	WELL			
AL	MacAdam	23	<13		L80 B20				

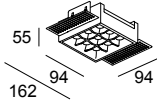

95x95 0-18 mm

LED						max.700mA 27V	
K	CRI	W	Real Lm	Optics	Code	14	60
2700	90	18.3	1680	17°	90-6358		
2700	90	18.3	1914	38°	90-6360 - 14		60
2700	90	18.3	1809	47°	90-6362		
3000	90	18.3	1680	17°	90-6359		
3000	90	18.3	1914	38°	90-6361 - 14		60
3000	90	18.3	1809	47°	90-6363		
4000	90	18.3	1826	17°	90-7002		
4000	90	18.3	2080	38°	90-7005 - 14		60
4000	90	18.3	1966	47°	90-7006		

Bento Tunable White

BODY MAT	3	IP		LOW FLICKER	WELL			
AL	MacAdam	23						

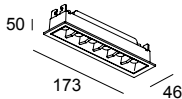

40x168 0-18 mm

LED						DALI DT8 220-240V	
K	CRI	W Total	Real Lm	Optics	Code	14	60
2700-6500	90	12.6	1169	38°	90-7804		
2700-6500	90	12.6	1042	48°	90-7805 - 14		60

Drivers Driver

P. 984

Bento 3 LEDS



Bento 6 LEDS



Bento 12 LEDS



Bento 18 LEDS



Bento Square



ON-OFF
IP20

71-B232-00-00

71-6658-00-00

71-6653-00-00

71-3542-00-00

71-6658-00-00



PHASE CUT
240V

71-7663-00-00

71-A299-00-00
Min.1 - Max.2

71-A299-00-00

71-B666-00-00

71-A229-00-00



DALI2
IP20

71-A190-00-00

71-6192-00-00

71-A192-00-00

71-A303-00-00

71-A192-00-00



CASAMBI
IP20

71-A261-00-00
Min.1 - Max.5

71-A260-00-00
Min.1 - Max.2

71-A260-00-00

-

71-A260-00-00

Bento Adjustable



The adjustable version of Bento allows the internal structure to move, meaning the light beam can be adjusted.

La version réglable de Bento permet le mouvement de la structure intérieure, ce qui offre la possibilité d'ajuster le faisceau lumineux.

Bento Adjustable 3 LEDS

BODY MAT	3	IP	UGR					
AL	MacAdam	23	<13					

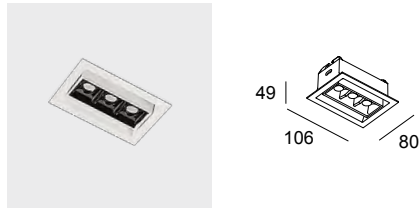

96x70 0-20 mm

LED						max.700mA 9V
K	CRI	W	Real Lm	Optics	Code	
2700	90	6.1	560	17°	90-7098	14 - 14
2700	90	6.1	638	38°	90-7099	60 - 60
2700	90	6.1	603	47°	90-7100	
3000	90	6.1	560	17°	90-7101	14 - 14
3000	90	6.1	638	38°	90-7161	60 - 60
3000	90	6.1	603	47°	90-7169	
4000	90	6.1	609	17°	90-7184	14 - 14
4000	90	6.1	693	38°	90-7185	60 - 60
4000	90	6.1	655	47°	90-7186	

Bento Adjustable 6 LEDS

BODY MAT	3	IP	UGR					
AL	MacAdam	23	<13					

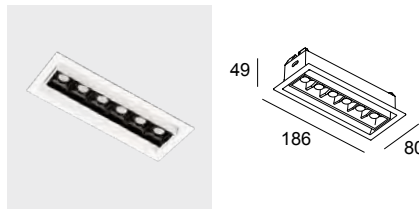

175x70 0-20 mm

LED						max.700mA 18V
K	CRI	W	Real Lm	Optics	Code	
2700	90	12.2	1119	17°	90-7187	14 - 14
2700	90	12.2	1276	38°	90-7188	60 - 60
2700	90	12.2	1205	47°	90-7189	
3000	90	12.2	1119	17°	90-7190	14 - 14
3000	90	12.2	1276	38°	90-7191	60 - 60
3000	90	12.2	1205	47°	90-7192	
4000	90	12.2	1216	17°	90-7193	14 - 14
4000	90	12.2	1387	38°	90-7194	60 - 60
4000	90	12.2	1310	47°	90-7195	

Bento Adjustable 3 LEDS



Bento Adjustable 6 LEDS



Drivers

P. 984

Drivers	Bento Adjustable 3 LEDS	Bento Adjustable 6 LEDS
ON-OFF IP20	71-B232-00-00	71-6658-00-00
PHASE CUT 240V IP20	71-7663-00-00	-
DALI2 IP20	71-A190-00-00	71-6192-00-00
CASAMBI IP20	71-A261-00-00 Min.1 - Max.5	71-A260-00-00 Min.1 - Max.2

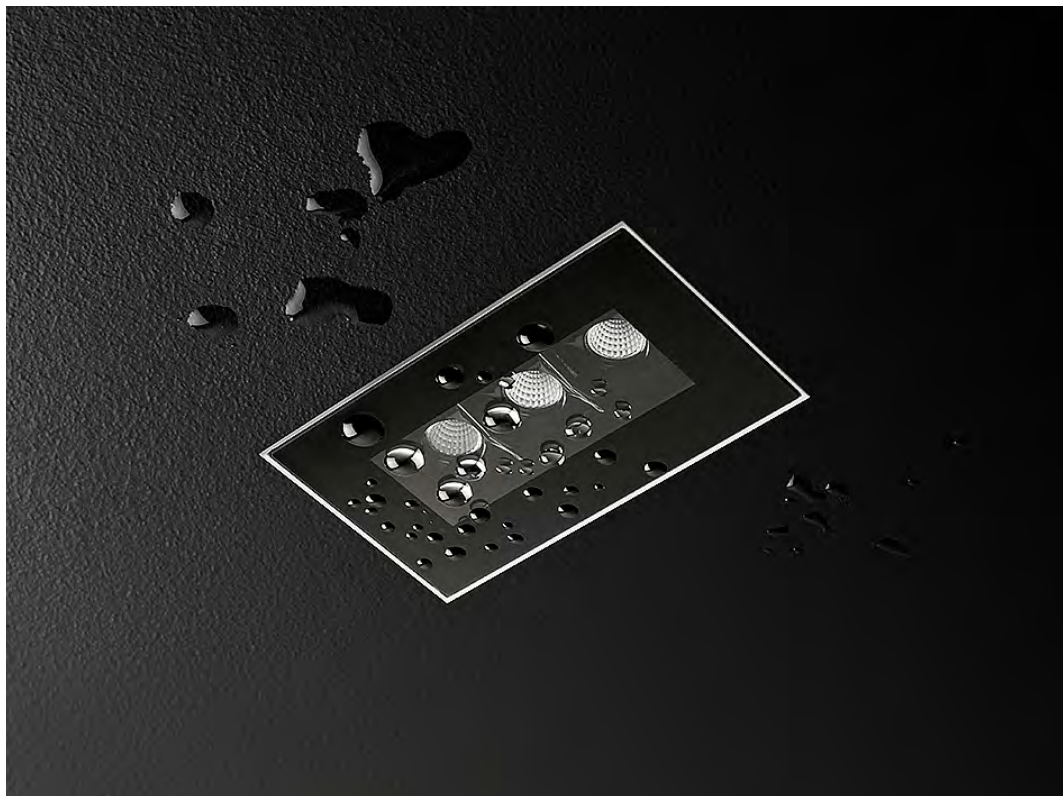

IP65 protection Protection IP65

With an IP65 protection rating, Bento IP Recessed can be installed in damp environments exposed to dust and water, while offering all the great features of the Bento collection.

Offrant une protection IP65, Bento IP Recessed peut s'installer en milieu humide ou exposé à la poussière ou à l'eau, sans sacrifier toutes les prestations de la collection Bento.

Bento IP 3 LEDS

BODY MAT	3	IP	DIF MAT	UGR		WELL			
AL	MacAdam	65	GLA	<13					

14 60

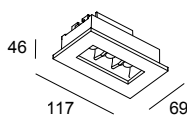

59x107 0-20 mm

LED						max.700mA 9V
K	CRI	W	Real Lm	Optics	Code	
2700	90	6.1	560	17°	90-7214	
2700	90	6.1	638	38°	90-7215 - 14 - 60	
2700	90	6.1	603	47°	90-7216	
3000	90	6.1	560	17°	90-7217	
3000	90	6.1	638	38°	90-7218 - 14 - 60	
3000	90	6.1	603	47°	90-7219	
4000	90	6.1	609	17°	90-7220	
4000	90	6.1	693	38°	90-7221 - 14 - 60	
4000	90	6.1	655	47°	90-7222	

Bento IP 6 LEDS

BODY MAT	3	IP	UGR	DIF MAT		WELL			
AL	MacAdam	65	<13	GLA					

14 60

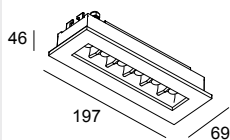

59x187 0-20 mm

LED						max.700mA 18V
K	CRI	W	Real Lm	Optics	Code	
2700	90	12.2	1119	17°	90-7223	
2700	90	12.2	1276	38°	90-7224 - 14 - 60	
2700	90	12.2	1205	47°	90-7225	
3000	90	12.2	1119	17°	90-7226	
3000	90	12.2	1276	38°	90-7227 - 14 - 60	
3000	90	12.2	1205	47°	90-7228	
4000	90	12.2	1216	17°	90-7229	
4000	90	12.2	1387	38°	90-7230 - 14 - 60	
4000	90	12.2	1310	47°	90-7231	

Bento IP 3 LEDS



Bento IP 6 LEDS



Drivers Driver

P. 984

	ON-OFF IP20	71-B232-00-00	71-6658-00-00
	PHASE CUT 240V IP20	71-7663-00-00	71-A299-00-00 Min.1 - Max.2
	DALI2 IP20	71-A190-00-00	71-6192-00-00 Min.1 - Max.3
	CASAMBI IP20	71-A261-00-00 Min.1 - Max.5	71-A260-00-00 Min.1 - Max.3

Fixing accessories Accessoires de fixation

	Trimless installation kit Kit d'installation sans cadre	71-7522-14-00	71-7523-14-00
--	------------------------------------------------------------	----------------------	----------------------

Bento Wall Washer

INDOOR



Thanks to new micro-engraved spoon-shaped reflectors, Bento Wall Washer creates a homogeneous, shadow-free, wall-bathing effect, while providing the environment with a shielding, thus maintaining the Dark Light effect that is characteristic of the entire Bento family. Grâce aux nouveaux réflecteurs microgravés en forme de cuillère, le lèche-mur Bento génère un éclairage mural homogène sans ombres, tout en offrant un environnement de protection, conservant ainsi l'effet Dark Light (lumière sombre) caractéristique de toute la famille Bento.

DOWNLIGHTS



Micro-engraved spoon-shaped reflectors
Réflecteurs microgravés en forme de cuillère

Bento Wall Washer

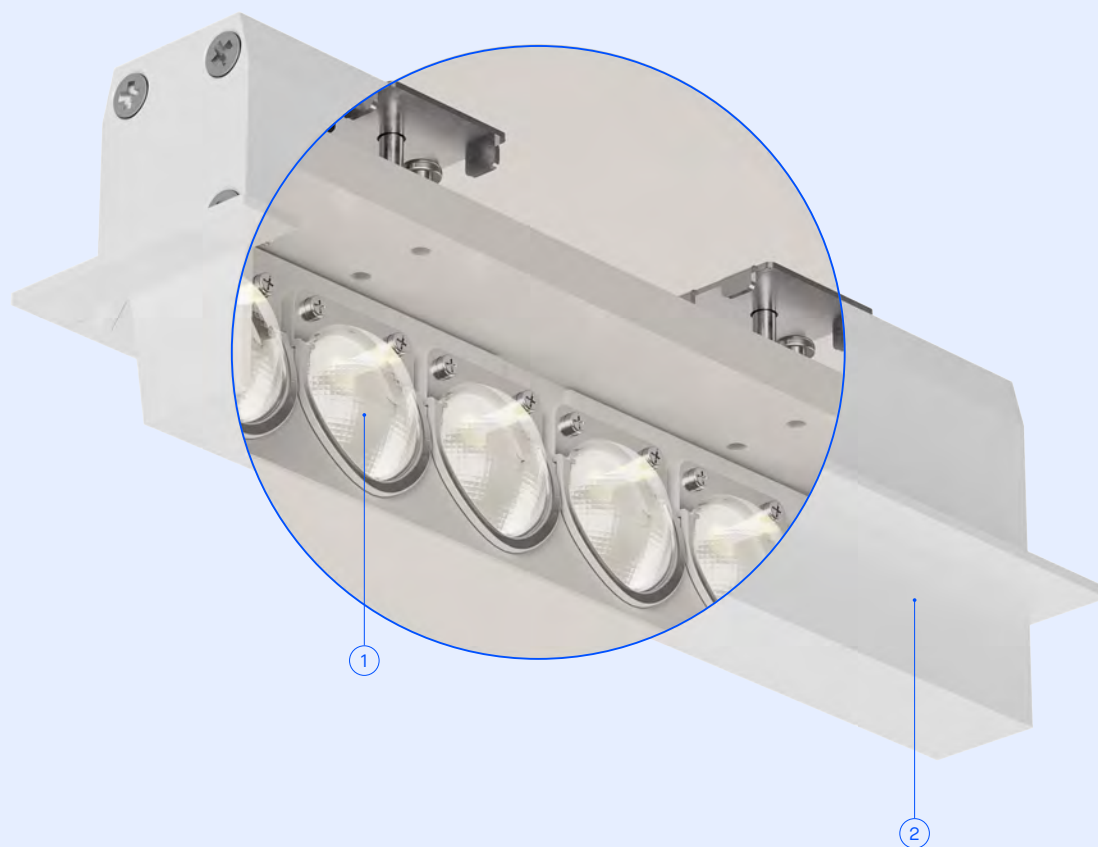

- ① Micro-engraved spoon-shaped reflectors for bathing walls in homogeneous light.
Réflecteurs microgravés en forme de cuillère pour un effet lèche-mur homogène.
- ② Longitudinal shade for Dark Light effect.
Abat-jour longitudinal pour effet Dark Light (lumière sombre).

Bento Wallwasher 3 LEDs Trim

BODY MAT	3
AL	MacAdam

IP	20
----	----

UGR	<10
-----	-----

50000h
L80 B20



50000h
L80 B20



○ ●
14 60

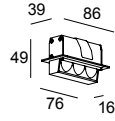

28x76 25 mm

LED					max.350mA 9V	
K	CRI	W	Real Lm	Code		
2700	90	3	207	90-A112	14	00
3000	90	3	230	90-A113	14	00
4000	90	3	276	90-A114	14	00

Bento Wallwasher 3 LEDs Trimless

BODY MAT	3
AL	MacAdam

IP	20
----	----

UGR	<10
-----	-----

50000h
L80 B20



50000h
L80 B20



○ ●
14 60

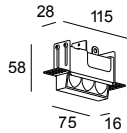

28x75 25 mm

LED					max.350mA 9V	
K	CRI	W	Real Lm	Code		
2700	90	3	207	90-A115	14	00
3000	90	3	230	90-A116	14	00
4000	90	3	276	90-A117	14	00

Bento Wallwasher 6 LEDs Trim

BODY MAT	3
AL	MacAdam

IP	20
----	----

UGR	<10
-----	-----

50000h
L80 B20



50000h
L80 B20



○ ●
14 60

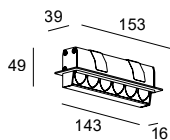

28x143 25 mm

LED					max.350mA 18V	
K	CRI	W	Real Lm	Code		
2700	90	6	421	90-A118	14	00
3000	90	6	468	90-A119	14	00
4000	90	6	562	90-A120	14	00

Bento Wallwasher 6 LEDs Trimless

BODY MAT	3
AL	MacAdam

IP	20
----	----

UGR	<10
-----	-----

50000h
L80 B20



50000h
L80 B20



○ ●
14 60

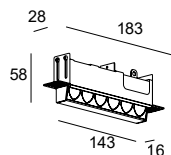

28x143 25 mm

LED					max.350mA 18V	
K	CRI	W	Real Lm	Code		
2700	90	6	421	90-A121	14	00
3000	90	6	468	90-A122	14	00
4000	90	6	562	90-A123	14	00

Bento Wallwasher 12 LEDS Trim

BODY MAT	3	IP	UGR	50000h L80 B20		
AL	MacAdam	20	<10			

○ ●
14 60

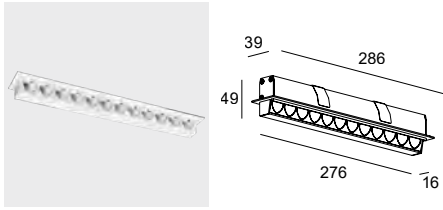

28x276 25 mm

LED						max.350mA 36V	
K	CRI	W	Real Lm	Code			
2700	90	12	842	90-A124	14	60	- 00
3000	90	12	936	90-A125	14	60	- 00
4000	90	12	1123	90-A126	14	60	- 00

Bento Wallwasher 12 LEDS Trimless

BODY MAT	3	IP	UGR	50000h L80 B20		
AL	MacAdam	20	<10			

○ ●
14 60

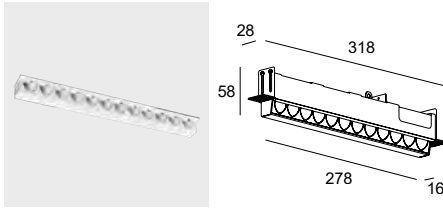

28x278 25 mm

LED						max.350mA 36V	
K	CRI	W	Real Lm	Code			
2700	90	12	842	90-A127	14	60	- 00
3000	90	12	936	90-A128	14	60	- 00
4000	90	12	1123	90-A129	14	60	- 00

	Bento Wallwasher 3 LEDS	Bento Wallwasher 6 LEDS	Bento Wallwasher 12 LEDS Trimless
--	--------------------------------	--------------------------------	------------------------------------------



Drivers

P. 984

Driver	71-B681-00-00	71-A652-00-00	71-6652-00-00
ON-OFF IP20			
PHASE CUT 240V IP20	71-4898-00-00 Min.1 - Max.5	71-4898-00-00 Min.1 - Max.2	71-A297-00-00
DALI2 IP20	71-B407-00-00 Min.2 - Max.4	71-B407-00-00 Min.1 - Max.2	71-B407-00-00
CASAMBI IP20	71-A260-00-00 Min.2 - Max.6	71-A260-00-00 Min.1 - Max.3	71-A260-00-00

Multidir Evo

Designed by LedsC4 Architectural

Ceiling
P. 285



INDOOR



+ Multidir Evo



Multidir Evo Recessed comes with a single and double lens in different finishes and with Trimy trimless options. Its new-and-improved Cardan system is an ideal choice for retail settings, both the LED and GU10 versions.

Multidir Evo Recessed est proposé avec une optique simple et double dans différentes finitions et avec des options Trimy sans collerette. Son système de cardan remanié et amélioré constitue un choix idéal pour les espaces de commerce de détail, tant en version LED que GU10.

DOWNLIGHTS



Multidir Evo Recessed Small Single

BODY MAT	DIF MAT	50000h	2	IP	
AL	PC	L80 B20	MacAdam	54	40°

Code example / Exemple d'élaboration d'une référence: **AU11-P8V9S30S60**

Model		W	K	CRI	Optics	Real Lm	Source	Finishes	
AU11 - Single / Trim 0-20 mm 110x110		P8V9	8.2	2700	90	S3 18°	967 - 1027	OS ON-OFF 220-240V	14 34 60
		P8W9	8.2	3000	90	M3 38°	965 - 1025	DU DALI-2 100-240V	
		P8X9	8.2	4000	90	F1 64°	964 - 1024	BB 36V/max.250mA	
		11V9	11.8	2700	90	S3 18°	1312 - 1394	OU ON-OFF 100-240V	
		11W9	11.8	3000	90	M3 38°	1310 - 1394	DU DALI-2/PUSH 100-240V	
		11X9	11.8	4000	90	F1 64°	1308 - 1390	XB CASAMBI 220-240V BB 36V/max.350mA	
AU12 - Single / Trimless 0-20 mm 100x100		18V9	17.3	2700	90	S3 18°	1798	OU ON-OFF 100-240V	
		18W9	17.3	3000	90	M3 38°	1794	DU DALI-2/PUSH 100-240V	
		18X9	17.3	4000	90	F1 64°	1792	XB CASAMBI 220-240V BB 36V/max.500mA	
		AAG1	Max. 8	GU10		NA		BU 100-240V	

Multidir Evo Recessed Big Single

BODY MAT	DIF MAT	50000h	2	IP	
AL	PC	L80 B20	MacAdam	54	40°

Code example / Exemple d'élaboration d'une référence: **AU17-P8V9S30S60**

Model		W	K	CRI	Optics	Real Lm	Source	Finishes	
AU17 - Single / Trim 0-20 mm 160x160		18V9	16.2	2700	90	S3 15°	2023 - 2150	OU ON-OFF 100-240V	14 34 60
		18W9	16.2	3000	90	M3 38°	1947 - 2069	DU DALI-2 100-240V	
		18X9	16.2	4000	90	F1 63°	1961 - 2083	XB CASAMBI 220-240V BB 36V/max.500mA	
		25V9	23.1	2700	90	S3 14°	2770 - 2943	OU ON-OFF 100-240V	
		25W9	23.1	3000	90	M3 38°	2715 - 2893	DU DALI-2 100-240V	
		25X9	23.1	4000	90	F1 63°	2684 - 2852	XB CASAMBI 220-240V BB 36V/max.700mA	
AU18 - Single / Trimless 0-20 mm 150x150		33V9	30.3	2700	90	S3 14°	3462 - 3678	OS ON-OFF 220-240V	
		33W9	30.3	3000	90	M3 38°	3332 - 3540	DU DALI-2 100-240V	
		33X9	30.3	4000	90	F1 63°	3355 - 3564	XB CASAMBI 220-240V BB 36V/max.900mA	
		39V9	41.4	2700	90	S3 15°	4431 - 4708	OS ON-OFF 220-240V	
		39W9	41.4	3000	90	M3 38°	4264 - 4531	DS DALI-2/PUSH 220-240V	
		39X9	41.4	4000	90	F1 63°	4294 - 4506	BB 36V/max.1200mA	
	AAG1	Max. 8	GU10		NA		BU 100-240V		

Multidir Evo Recessed Small Double

BODY MAT	DIF MAT	50000h	2	IP	
AL	PC	L80 B20	MacAdam	54	40°

Code exemple / Exemple d'élaboration d'une référence: **AU13-P8V9S30S60**

Model	W	K	CRI	Optics	Real Lm	Source	Finishes	
AU13 - Double / Trim 0-20 mm 208x110	P8V9	17.3	2700	90	S3 17°	1934 - 2054	OU ON-OFF 100-240V	14 34 60
	P8W9	17.3	3000	90	M3 38°	1934 - 2054	DU DALI-2 100-240V	
	P8X9	17.3	4000	90	F1 64°	1928 - 2048	XB CASAMBI 220-240V	
							BB 2x36V/max.250mA	
	11V9	25.1	2700	90	S3 18°	2624 - 2788	OS ON-OFF 220-240V	
	11W9	25.1	3000	90	M3 38°	2620 - 2784	DU DALI-2/PUSH 100-240V	
AU14 - Double / Trimless 0-20 mm 200x100	11X9	25.1	4000	90	F1 64°	2616 - 2780	XB CASAMBI 220-240V	14 34 60
							BB 2x36V/max.350mA	
	18V9	34.6	2700	90	S3 17°	3596 - 3820	OS ON-OFF 220-240V	
	18W9	34.6	3000	90	M3 38°	3588 - 3812	DS DALI-2 220-240V	
	18X9	34.6	4000	90	F1 64°	3584 - 3808	XB CASAMBI 220-240V	
							BB 2x36V/max.500mA	
AAG1	2 x Max 8.	GU10		NA		BU 100-240V		

Multidir Evo Recessed Big Double

BODY MAT	DIF MAT	50000h	2	IP	
AL	PC	L80 B20	MacAdam	54	40°

Code exemple / Exemple d'élaboration d'une référence: **AU19-P8V9S30S60**

Model	W	K	CRI	Optics	Real Lm	Source	Finishes	
AU19 - Double / Trim 0-20 mm 310x160	18V9	34	2700	90	S3 15°	4046 - 4300	OS ON-OFF 220-240V	14 34 60
	18W9	34	3000	90	M3 38°	3894 - 4138	DS DALI-2 220-240V	
	18X9	34	4000	90	F1 63°	3922 - 4166	XB CASAMBI 220-240V	
							BB 2x36V/max.500mA	
	25V9	49.1	2700	90	S3 14°	5540 - 5886	OU ON-OFF 100-240V	
	25W9	49.1	3000	90	M3 38°	5330 - 5664	DS DALI-2 220-240V	
AU21 - Double / Trimless 0-20 mm 303x150	25X9	49.1	4000	90	F1 63°	5368 - 5704	XB CASAMBI 220-240V	14 34 60
							BB 2x36V/max.700mA	
	33V9	60.6	2700	90	S3 14°	6924 - 7356	OS ON-OFF 220-240V	
	33W9	60.6	3000	90	M3 38°	6664 - 7080	DU DALI-2/PUSH 100-240V	
	33X9	60.6	4000	90	F1 63°	6710 - 7128	XB CASAMBI 220-240V	
							BB 2x36V/max.900mA	
39V9	82.8	2700	90	S3 15°	8862 - 9416	OS ON-OFF 220-240V	14 34 60	
39W9	82.8	3000	90	M3 38°	8528 - 9062	DS DALI-2 220-240V		
39X9	82.8	4000	90	F1 63°	8588 - 9124	BB 2x36V/max.900mA		
AAG1	2 x Max 8.	GU10		NA		BU 2x36V/max.1200mA		

Lens accessories Accessoires optiques



Honeycomb panel (5u.)
Grille en nid d'abeille (5 u.)

Multidir Small

71-A854-60-00

Multidir Big

71-A855-60-00

Totem



+ Totem



Lighting should not steal the limelight from the space's design. It should be integrated with it without sacrificing lighting quality and it should draw attention to the products on display. Totem can be tilted at an angle of up to 30°, which avoids glare on the trim of the light fitting, thus creating a clean and comfortable effect.

L'éclairage ne doit pas nuire à la conception de l'espace, mais s'y intégrer sans compromettre la qualité de la lumière et en mettant correctement en valeur les produits exposés. Totem présente un angle d'inclinaison pouvant atteindre 30°, ce qui évite les reflets sur le cadre du luminaire et assure un effet net et confortable.

Lens tilt angle of up to 30°
Angle d'inclinaison de
l'optique jusqu'à 30°





Accent lighting. In retail settings, Totem draws shoppers' attention to the right areas.
Éclairage d'accentuation. Dans le secteur Retail, Totem parvient à attirer l'attention du consommateur vers la zone requise.



106 lm / W efficiency
Efficience de 106 lm / W.

Customisable LEDs with
a range of spectrums
to highlight products
according to needs
Ampoules LED
personnalisables avec
différents spectres pour
mettre en valeur les
produits selon les besoins



A. Standard lighting / Éclairage standard
B. Totem lighting / Éclairage Totem

Totem Simple Ø55

BODY MAT	DIF MAT		50000h	2	IP						
AL	PC		L80 B20	MacAdam	20						

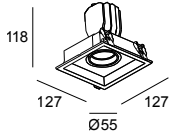

114×114 0-15 mm

LED										
K	CRI	W Total	Real Lm	Optics	Code					
3000	92	25	2272	15°	90-A054					
3000	92	25	2250	24°	90-A055	H2	OS	ON-OFF	220-240V	
3000	92	25	2227	38°	90-A056	G7	DS	DALI	220-240V	
3500	92	25	2297	15°	90-A057					
3500	92	25	2275	24°	90-A058	H2	OS	ON-OFF	220-240V	
3500	92	25	2252	38°	90-A059	G7	DS	DALI	220-240V	
4000	92	25	2362	15°	90-A091					
4000	92	25	2339	24°	90-A092	H2	OS	ON-OFF	220-240V	
4000	92	25	2315	38°	90-A093	G7	DS	DALI	220-240V	

H2 G7

Totem Simple Ø80

BODY MAT	DIF MAT		50000h	2	IP						
AL	PC		L80 B20	MacAdam	20						

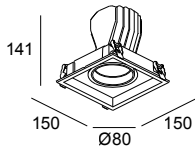

137×137 0-15 mm

LED										
K	CRI	W Total	Real Lm	Optics	Code					
3000	92	34	3280	24°	90-A045					
3000	92	34	3217	38°	90-A046	H2	OS	ON-OFF	220-240V	
3000	92	34	3375	55°	90-A053	G7	DS	DALI	220-240V	
3500	92	34	3489	24°	90-A047					
3500	92	34	3468	38°	90-A048	H2	OS	ON-OFF	220-240V	
3500	92	34	3326	55°	90-A049	G7	DS	DALI	220-240V	
4000	92	34	3602	24°	90-A050					
4000	92	34	3656	38°	90-A051	H2	OS	ON-OFF	220-240V	
4000	92	34	3436	55°	90-A052	G7	DS	DALI	220-240V	

H2 G7

Totem Simple Ø80 Bread / Fish / Meat

BODY MAT	DIF MAT		50000h	2	IP						
AL	PC		L80 B20	MacAdam	20						

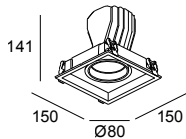

137×137 0-15 mm

LED										
K		W Total	Real Lm	Optics	Code					
Meat		34	1844	38°	90-A088	H2	OS	ON-OFF	220-240V	
						G7				
Bread		34	2937	38°	90-A090	H2	OS	ON-OFF	220-240V	
						G7				
Fish		34	3098	38°	90-A089	H2	OS	ON-OFF	220-240V	
						G7				

H2 G7

Totem Double Ø55

BODY MAT	DIF MAT		50000h	2	IP					
AL	PC		L80 B20	MacAdam	20					

○ ●
H2 G7

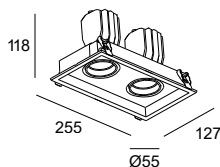

242x114 0-15 mm

LED									
K	CRI	W Total	Real Lm	Optics	Code				
3000	92	2 × 25	4544	15°	90-A111				
3000	92	2 × 25	4500	24°	90-A110	H2	OS	ON-OFF 220-240V	
3000	92	2 × 25	4454	38°	90-A109	G7	DS	DALI 220-240V	
3500	92	2 × 25	4594	15°	90-A108				
3500	92	2 × 25	4550	24°	90-A107	H2	OS	ON-OFF 220-240V	
3500	92	2 × 25	4504	38°	90-A106	G7	DS	DALI 220-240V	
4000	92	2 × 25	4630	15°	90-A105				
4000	92	2 × 25	4678	24°	90-A104	H2	OS	ON-OFF 220-240V	
4000	92	2 × 25	4724	38°	90-A103	G7	DS	DALI 220-240V	

Totem Double Ø80

BODY MAT	DIF MAT		50000h	2	IP					
AL	PC		L80 B20	MacAdam	20					

○ ●
H2 G7

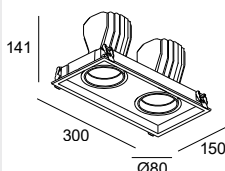

289x137 0-15 mm

LED									
K	CRI	W Total	Real Lm	Optics	Code				
3000	92	2 × 34	6750	24°	90-A094	H2	OS	ON-OFF 220-240V	
3000	92	2 × 34	6560	38°	90-A095	G7	DS	DALI 220-240V	
3500	92	2 × 34	6978	24°	90-A096	H2	OS	ON-OFF 220-240V	
3500	92	2 × 34	6936	38°	90-A097	G7	DS	DALI 220-240V	
4000	92	2 × 34	7204	24°	90-A098	H2	OS	ON-OFF 220-240V	
4000	92	2 × 34	7312	38°	90-A099	G7	DS	DALI 220-240V	

Totem Triplex Ø55

BODY MAT	DIF MAT		50000h	2	IP					
AL	PC		L80 B20	MacAdam	20					

○ ●
H2 G7

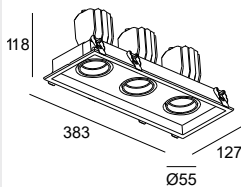

370x114 0-15 mm

LED									
K	CRI	W Total	Real Lm	Optics	Code				
3000	92	3 × 25	6750	24°	90-A102	H2	OS	ON-OFF 220-240V	
						G7	DS	DALI 220-240V	
3500	92	3 × 25	6825	24°	90-A101	H2	OS	ON-OFF 220-240V	
						G7	DS	DALI 220-240V	
4000	92	3 × 25	7017	24°	90-A100	H2	OS	ON-OFF 220-240V	
						G7	DS	DALI 220-240V	

Connective controllers Contrôleurs connectés

P. 969



Consult the available control systems / Consultez les systèmes de contrôle disponibles:

DALI2 / DALI2

Bluetooth wireless / Sans fil Bluetooth

Autonomous / Autonome

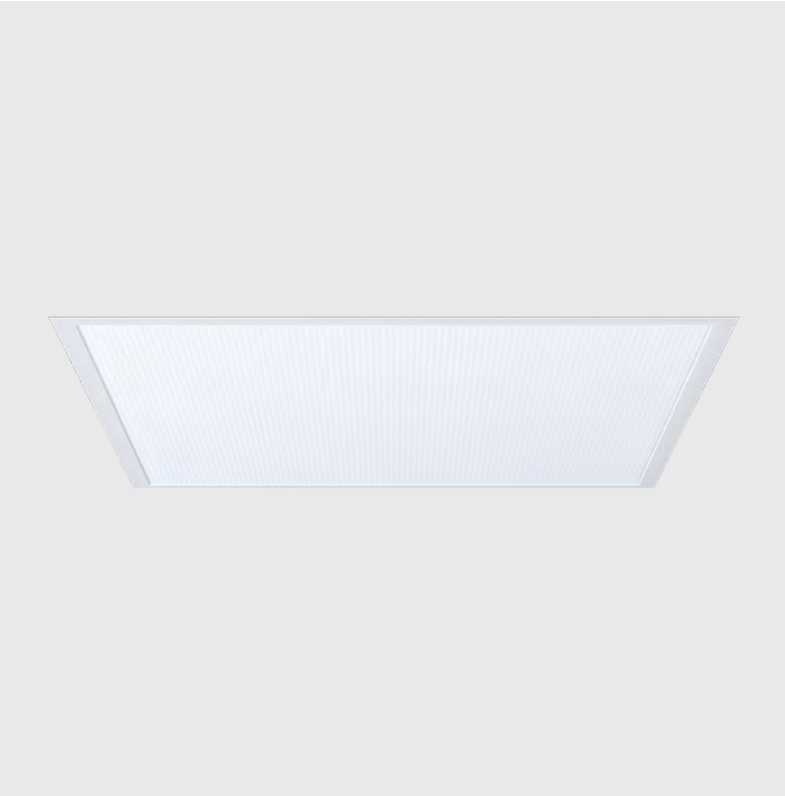

Efficiency and comfort for lighting workspaces Efficacité et confort pour l'éclairage des espaces de travail

Workspaces are becoming more demanding, requiring comfortable and inclusive lighting that enhances people's well-being and health. Ecofit is a collection of highly efficient panels with two lens options to suit the diverse needs of the area being lit.

Les espaces de travail sont de plus en plus exigeants et nécessitent un éclairage confortable et inclusif, qui améliore le bien-être et la santé des personnes. Ecofit est une collection de panneaux très efficaces avec deux possibilités d'optiques pour s'adapter aux différents besoins de la zone à éclairer.



Highly efficient light intensity control Luminance contrôlée à haut niveau d'efficacité



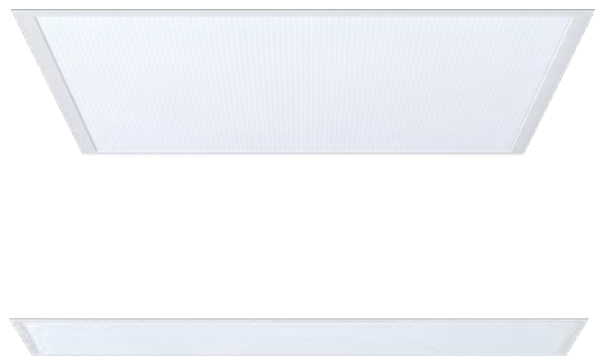

Smart functionality Fonctionnalité Smart



These smart functionalities include energy saving by sensing natural light or presence and data collection to monitor occupancy.

Parmi ces fonctionnalités, figurent l'économie d'énergie via l'apport de lumière naturelle ou la présence, ainsi que la collecte de données destinée au suivi du taux d'occupation de l'espace.

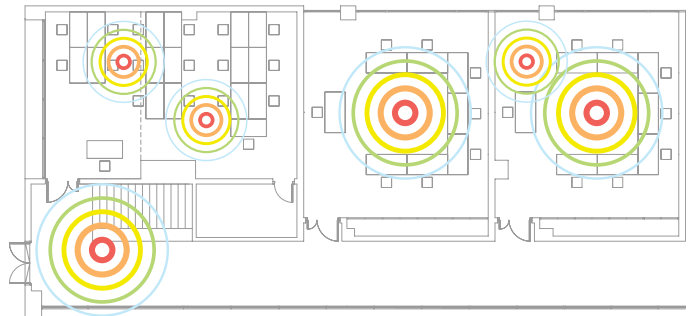





Shallow height for easy integration Hauteur réduite pour une intégration facile

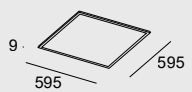

Ecofit Plus

BODY MAT	50000h	3	IP	UGR	
AL	L80 B20	MacAdam	40	<19	

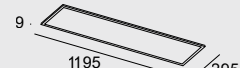
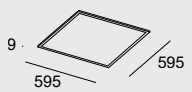
Code example / Exemple d'élaboration d'une référence: **AP11-35W8MPOS14**

Model	Optics	W	K	CRI	Real Lm	Source	Finishes
AP51 - Square / 595 × 595 	3PW8MP Microprisma	27.7	3000	80	3350	OS  ON-OFF 220-240V	14 
	3PX8MP Microprisma	27.7	4000	80	3490	DS  DALI-2/PUSH 220-240V	
	3PW8MP Microprisma	27.7	3000	80	3350	BB  40V/max.750mA	
	3PX8MP Microprisma	27.7	4000	80	3490		
AP52 - Rectangular / 1195 × 295 							
AP51 - Square / 595 × 595 	3PU8MP Microprisma	33	TW 2700- 6500	80	3600	TW  DALI DT8 220-240V	

Ecofit Plus 595 × 595mm



**ON-OFF /
Not Included**

**DALI /
DALI DT8**

Ecofit Plus 1195 × 295mm







**ON-OFF /
Not Included**

DALI

Fixing accessories

Accessoires de fixation

	Suspended ceiling rose with electrical outlet (2500mm) Patère suspendue avec prise de courant (2500mm)	71-7520-14-00	-	71-7520-14-00	-
	DALI suspended ceiling rose with electrical outlet (2500mm) Patère suspendue avec prise de courant DALI (2500mm)	-	71-7521-14-00	-	71-7521-14-00
	Surface installation kit Kit d'installation de surface	71-A329-14-00	71-A329-14-00	71-A331-14-00	71-A331-14-00
	Recessing kit for false ceiling Kit d'encastrement dans faux plafond	71-A330-14-00	71-A330-14-00	71-A724-14-00	71-A724-14-00
	Pendant installation kit (2000mm) Kit d'installation pour suspension (2000mm)	71-A332-00-00	71-A332-00-00	71-A333-00-00	71-A333-00-00

BODY MAT	50000h	3	IP	DIF MAT	UGR		
AL	L80 B20	MacAdam	40	PMMA	<19		

Code example / Exemple d'élaboration d'une référence: **AQ11-3PW8F30S14**

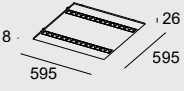
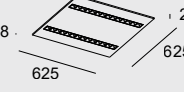
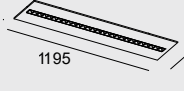
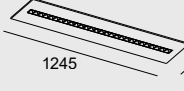
Model	Optics	W	K	CRI	Real Lm	Source	Finishes
AQ11 - Square / 595 × 595 	3PW8F3 Opticell	29.3	3000	80	4402	OS ON-OFF 220-240V	14
	3PW9F3 Opticell	29.3	3000	90	3962	DS DALI-2 220-240V	
	3PX8F3 Opticell	29.3	4000	80	4596	XB CASAMBI 220-240V	
	3PX9F3 Opticell	29.3	4000	90	3962		
AQ12 - Square / 625 × 625 	3PU8F3 Opticell	29.5	TW 2700- 6500	80	3224	TW DALI DT8 220-240V	
AQ13 - Rectangular / 1195 × 295 							
AQ14 - Rectangular / 1245 × 310 							



Ecofit Opticell
595 × 595mm



Ecofit Opticell
625 × 625



Ecofit Opticell
1195 × 295mm



Ecofit Opticell
1245 × 310mm



Fixing accessories
Accessoires de fixation

	Suspended ceiling rose with electrical outlet (2500mm) Patère suspendue avec prise de courant (2500mm)	71-7520-14-00	-	71-7520-14-00	-
	DALI suspended ceiling rose with electrical outlet (2500mm) Patère suspendue avec prise de courant DALI (2500mm)	71-7521-14-00	-	71-7521-14-00	-
	Surface installation kit Kit d'installation de surface	71-A329-14-00	-	71-A331-14-00	-
	Recessing kit for false ceiling Kit d'encastrement dans faux plafond	71-A330-14-00	-	71-A724-14-00	-
	Pendant installation kit (2000mm) Kit d'installation pour suspension (2000mm)	71-A332-00-00	-	71-A333-00-00	-

Pendants Suspensions

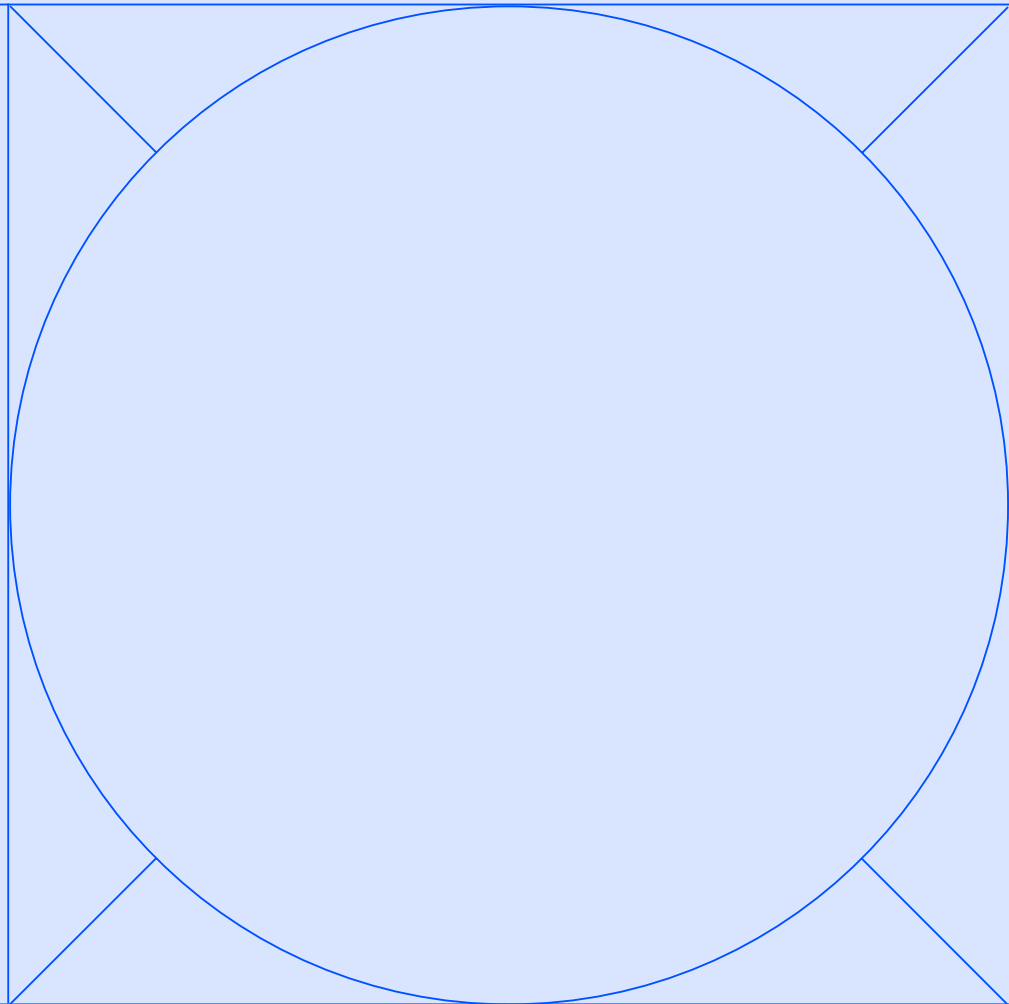

Pek
262

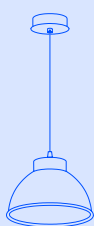

Luno Slim
264

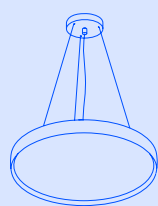

Iris
268



Play
271



Pek



Featuring a classic bell shape, in matte black and white finishes, Pek provides a high light flux without sacrificing style, bringing great aesthetic value to the space.

Avec sa forme classique de cloche, en finition noir mat et blanc, Pek assure un flux lumineux élevé sans renoncer au style, qui apporte une grande valeur esthétique à l'espace.



Option to install within a track by means of a connecting accessory or as a pendant light, with an adjustable cable size from 470mm to 2800mm

Possibilité d'installation sur rail au moyen d'un accessoire de raccordement ou en suspension, avec une section de câble réglable de 470 mm à 2800 mm

Pek LED

BODY MAT	DIF MAT		50000h	2	
AL	PC		L80 B20	MacAdam	

○ ●
14 60

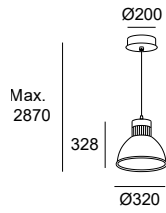

LED						
K	CRI	W Total	Real Lm	Code		
3000	80	35.2	2512	00-4941		
3000	80	44	4193	00-4947	14 - 60	ON-OFF 100-240V
3000	90	44	3347	00-4953		
4000	80	35.2	2512	00-4944	14 - 60	ON-OFF 100-240V
4000	80	44	4193	00-4950	14 - 60	ON-OFF 100-240V

Pek E27

BODY MAT	DIF MAT	
AL	PC	

○ ●
14 60

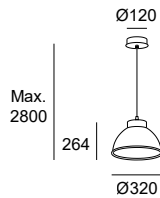

E27	
W	Code
Max. 15	00-4962 - 14 - 60 - 00

Pek LED



Pek E27



Connection accessories Accessoires de connexion



Track connector
Connecteur de rail

60
●

71-3531-60-00

Luno Slim

Designed by LedsC4 Architectural

Ceiling
P. 279



+ Luno Slim



Maximum performance
and comfort

Maximum de rendement et
de confort

Luno Slim is the ideal option for lighting areas requiring maximum efficiency due to their functionality. Available in different colour temperatures and different sizes and finishes. Luno Slim est l'option idéale pour éclairer les zones qui exigent un maximum d'efficacité du fait de leur fonctionnalité. Disponible en différentes températures de couleur, tailles et finitions.

Microprismatic diffuser with an
efficiency up to 120 lm/w
Diffuseur microprismatique avec une
efficacité allant jusqu'à 120 lm/w

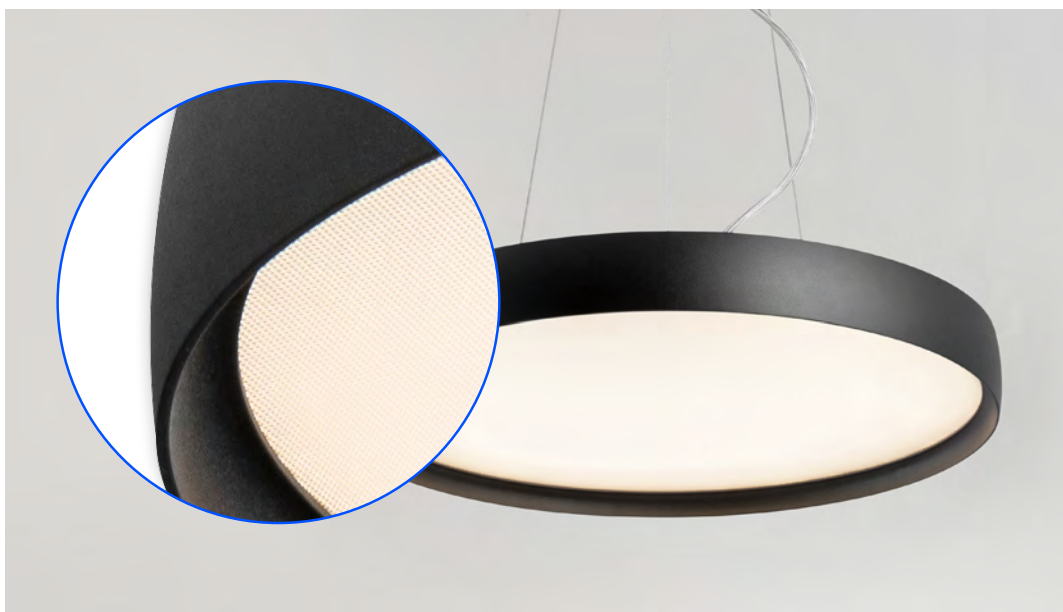



Iberspa project. **Luno Slim** Installation to enhance natural light. UGR<19. Efficiency 114 lm/w. Fotografia: Jordi Anguera.
Projet Iberspa. Installation **Luno Slim** pour valoriser la lumière naturelle. UGR<19. Efficacité 114 lm/w. Photographie: Jordi Anguera.

Streamlined profile
Profilé particulièrement fin

60 mm



Special cable tensioners to provide suitable stiffness and stability for the piece
Tendeurs de câble spéciaux qui confèrent à la pièce le niveau de rigidité et de consistance adapté

Luno Slim Small

BODY MAT	DIF MAT		50000h	3	IP	UGR		
AL	PC		L80 B20	MacAdam	20	<19		

Code example / Exemple d'élaboration d'une référence: **AR21-27W9MPDS14**

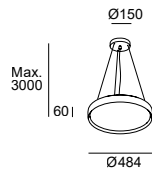

K	W	CRI	Optics	Lm	Code	Finishes
3000	27.8	90	Microprisma	3037	AR21-27W9MPDSXX	14 ○ ON-OFF/DALI-2/
4000	27.8	90	Microprisma	3158	AR21-27X9MPDSXX	60 ● PUSH 220-240V

Luno Slim Medium

BODY MAT	DIF MAT		50000h	3	IP	UGR		
AL	PC		L80 B20	MacAdam	20	<19		

Code example / Exemple d'élaboration d'une référence: **AR22-37W9MPDS14**

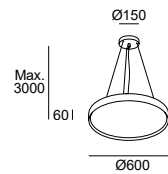

K	W	CRI	Optics	Real Lm	Code	Finishes
3000	37.8	90	Microprisma	3956	AR22-37W9MPDSXX	14 ○ ON-OFF/DALI-2/
4000	37.8	90	Microprisma	4114	AR22-37X9MPDSXX	60 ● PUSH 220-240V

Luno Slim Large

BODY MAT	DIF MAT		50000h	3	IP	UGR		
AL	PC		L80 B20	MacAdam	20	<19		

Code example / Exemple d'élaboration d'une référence: **AR23-72W9MPDS14**

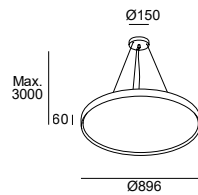

K	W	CRI	Optics	Real Lm	Code	Finishes
3000	71.3	90	Microprisma	6917	AR23-72W9MPDSXX	14 ○ ON-OFF/DALI-2/
4000	71.3	90	Microprisma	7194	AR23-72X9MPDSXX	60 ● PUSH 220-240V

Luno Slim Extra Large

BODY MAT	DIF MAT		50000h	3	IP	UGR		
AL	PC		L80 B20	MacAdam	20	<19		

Code example / Exemple d'élaboration d'une référence: **AR24-CPW9MPDS14**

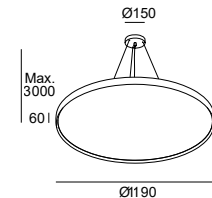

K	W	CRI	Optics	Real Lm	Code	Finishes
3000	108.2	90	Microprisma	9863	AR24-CPW9MPDSXX	14 ○ ON-OFF/DALI-2/
4000	108.2	90	Microprisma	10257	AR24-CPX9MPDSXX	60 ● PUSH 220-240V

XX= Replace for finish code: 14 or 60

Iris

Designed by Artec Studio



Low Voltage
P. 120



Spotlight
P. 274



Ceiling
P. 274



Spotlight Surf.
P. 274



Organic charisma Charisme organique

With its organic character, Iris takes over the space with an innate charm, offering quality lighting without sacrificing aesthetics and the interplay of compositions offered by its components and finishes.

Grâce à son caractère organique, Iris s'approprié les espaces avec charisme, offrant un éclairage de qualité sans renoncer à l'aspect esthétique et au jeu de composition de ses éléments et finitions.



Option to control the light beam thanks to the available accessories Possibilité de contrôler le faisceau lumineux grâce aux accessoires disponibles





Iris Pendant

BODY MAT		50000h	2	IP		
AL		L80 B20	MacAdam	23		

Code exemple / Exemple d'élaboration d'une référence: **AV14-P6V9U10S60**

Model		W	K	CRI	Optics	Real Lm		Source	Finishes
 AV14- Pendant Trim 0-20 mm 57	P6V9	6.3	2700	90	U Hoop	533-750	1 15°	OS ON-OFF 220-240V	60
	P6W9	6.3	3000	90	V Visual	249-357	2 35°	DS DALI-2 110-277V	
	P6X9	6.3	4000	90	X Cone Y Glass Z Pipe	527-707 382-461 376-466	3 50°		
 AV15 - Pendant Trimless 0-20 mm 57	12V9	12.5	2700	90	U Hoop	1183-1573	1 15°	OS ON-OFF 100-240V	60
	12W9	12.5	3000	90	V Visual	518-689	2 35°	DS DALI-2 110-277V	
	12X9	12.5	4000	90	X Cone Y Glass Z Pipe	1211-1477 782-1023 869-1023	3 50°		
 AV16 - Pendant Surface	18V9	18.1	2700	90	U Hoop	1592-2142	1 15°	OS ON-OFF 110-277V	60
	18W9	18.1	3000	90	V Visual	711-939	2 35°	DS DALI-2 110-277V	
	18X9	18.1	4000	90	X Cone Y Glass Z Pipe	1653-2037 1071-1360 1161-1422	3 50°		
 AV26 - Pendant Surface Big IP23									

* Rossete with Driver included



Finishes / Finitions

Selection of finishes available on the online configurator
 Sélection de finitions disponibles grâce au configurateur en ligne



Configurator
Configurateur
iris.ledsc4.com



Lens accessories Accessoires optiques

	Elliptical diffuser (5u.) Diffuseur elliptique (5 u.)	71-5167-00-00		Honeycomb panel (5u.) Grille en nid d'abeille (5 u.)	71-5166-60-00
	Square diffuser (5u.) Diffuseur carré (5 u.)	71-5658-00-00		Screen (5u.) Diffuseur (5 u.)	71-7895-60-00
	Halo fader (5u.) Diffuseur de halo (5 u.)	71-6099-00-00			



+ Play

Downlights
P. 184



Track
P. 096



Ceiling
P. 283



Spotlight
P. 283



Play Deco now comes as a pendant version in all variety of finishes, for projects requiring both technicality and design.

Play Deco se présente dans une option suspendue comme une nouveauté dans la gamme complète des finitions, pour les projets qui exigent technicité et design à parts égales.

Play Deco Pendant

BODY MAT	DIF MAT		50000h	2		
AL	PMMA		L80 B20	MacAdam		

Code exemple / Exemple d'élaboration d'une référence: **AG68-P7V9S20UWG**

Model	W	K	CRI	Real Lm	Optics	Source	Finishes
<p>AG68 - Pendant Surface Round</p>	P7V9	6.4	2700	90	521-554	S2 15° OU ON-OFF 100-240V	WG
	P7W9	6.4	3000	90	604-642	M2 28° TS PHASE CUT 220-240V	WH
	P7X9	6.4	4000	90	604-646	F1 49° DU DALI-2 110-277V	WL
	13V9	11.9	2700	80	1070-1167	S2 20° OU ON-OFF 100-240V	WM
	13W9	11.9	3000	80	1152-1276	M2 33° TS PHASE CUT 220-240V	WN
	13X9	11.9	4000	80	1233-1344	F1 44° DU DALI-2 110-277V	WR

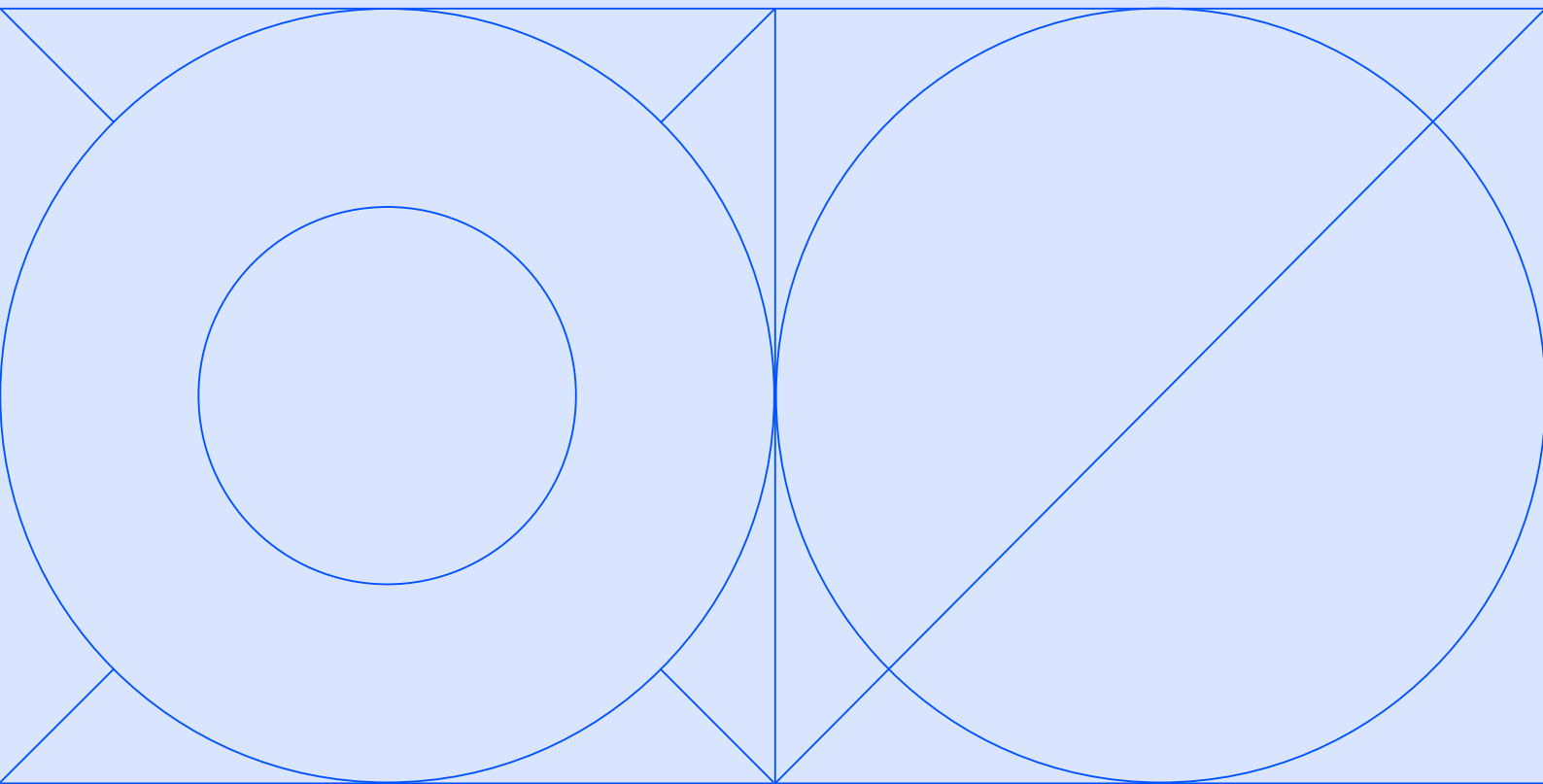

Spotlights / Ceilings

Projecteurs / Plafonniers

Iris Ceiling

274



Iris Spotlight

274



Leco

278



Luno Slim

279



Ges

282



Play Deco

283



Exit

284



Multidir Evo

285

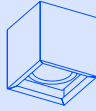

Atom Surface

291



Atom Hide

300

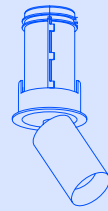

Atom Recessed

306

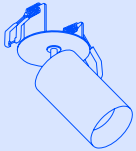

Bento Surface

309

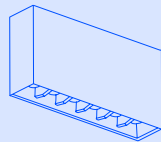

Bento IP

311

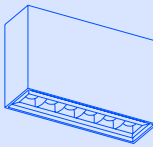

Kiva Surface

313



Kiva Recessed

314



Iris

Designed by Artec Studio



+ Iris

Spotlight
P. 086

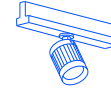

Low Voltage
P. 120



Pendant
P. 268



The Iris collection features ceiling lights and spotlights, making it an ideal solution for projects requiring an extensive and quality colour range, such as art galleries or similar. Se déclinant sous forme de plafonniers et de projecteurs, Iris est une solution idéale pour les projets qui nécessitent une gamme chromatique étendue et de qualité, notamment les galeries d'art ou espaces similaires.



Accessories to sculpt the light Accessoires qui façonnent la lumière



Iris can be installed with accessories for various purposes, such as accentuating the beam to focus on precise objects.

Iris permet l'installation d'accessoires aux usages variés, comme accentuer le faisceau pour se concentrer sur des objets précis.

Honeycomb panel accessory. Improves visual comfort and redefines the outlet angle.
Accessoire nid d'abeille. Augmente le confort visuel et accentue l'angle de sortie.



Iris Ceiling

IP	BODY MAT		50000h	2		
23	AL		L80 B20	MacAdam		

Code example / Exemple d'élaboration d'une référence: **AV17-P6V9U10S60**

Model		W	K	CRI	Shade	Real Lm	Optics	Source	Finishes						
 AV17 - Ceiling Surface	P6V9	6.3	2700	90	U Hoop	533-750	1 15°	OS  ON-OFF 220-240V	60 						
	P6W9	6.3	3000	90	V Visual	249-357	2 35°	DS  DALI-2 110-277V							
	P6X9	6.3	4000	90	X Cone	527-707	3 50°								
					Y Glass	382-461									
					Z Pipe	376-466									
 AV27 - Ceiling Surface Big	12V9	12.5	2700	90	U Hoop	1183-1573	1 15°	OS  ON-OFF 220-240V	60 						
	12W9	12.5	3000	90	V Visual	518-689	2 35°	DS  DALI-2 110-277V							
	12X9	12.5	4000	90	X Cone	1211-1477	3 50°								
					Y Glass	782-1023									
					Z Pipe	869-1023									
	18V9	18.1	2700	90	U Hoop	1592-2142	1 15°	OS  ON-OFF 110-277V	60 						
					18W9	18.1				3000	90	V Visual	711-939	2 35°	DS  DALI-2 110-277V
					18X9	18.1				4000	90	X Cone	1653-2037	3 50°	
	Y Glass	1071-1360													
Z Pipe	1161-1422														



AV17 - Driver remote (except 6W/12W on/off built-in)
 AV27 - Driver built-in

Finishes / Finitions

Selection of finishes available on the online configurator
 Sélection de finitions disponibles grâce au configurateur en ligne







Configurator
Configurateur
iris.ledsc4.com



Lens accessories

Accessoires optiques

	Elliptical diffuser (5u.) Diffuseur elliptique (5 u.)	71-5167-00-00		Panel de abeja (5u.) Painel de abelha (5u.)	71-5166-60-00
	Square diffuser (5u.) Diffuseur carré (5 u.)	71-5658-00-00		Apantallador (5u.) Obturador assimétrico (5u.)	71-7895-60-00
	Halo fader (5u.) Diffuseur de halo (5 u.)	71-6099-00-00			

Iris Spotlight

IP	BODY MAT		50000h	2				
23	AL		L80 B20	MacAdam		90°		

Code example / Exemple d'élaboration d'une référence: **AV11-P6V9U10S60**

Model	W	K	CRI	Shade	Real Lm	Optics	Source	Finishes	
 Max. 120 Ø55 0-20 mm 57	P6V9	6.3	2700	90	U Hoop	533-750	1 15°	OS ON-OFF 220-240V	60 ●
	P6W9	6.3	3000	90	V Visual	249-357	2 35°	DS DALI-2 110-277V	
	P6X9	6.3	4000	90	X Cone	527-707	3 50°		
					Y Glass	382-461			
					Z Pipe	376-466			
 Max. 120 Ø55 0-20 mm 57	12V9	12.5	2700	90	U Hoop	1183-1573	1 15°	OS ON-OFF 100-240V	60 ●
	12W9	12.5	3000	90	V Visual	518-689	2 35°	DS DALI-2 110-277V	
	12X9	12.5	4000	90	X Cone	1211-1477	3 50°		
					Y Glass	782-1023			
					Z Pipe	869-1023			
 Max. 150 Ø55	18V9	18.1	2700	90	U Hoop	1592-2142	1 15°	OS ON-OFF 110-277V	60 ●
	18W9	18.1	3000	90	V Visual	711-939	2 35°	DS DALI-2 110-277V	
	18X9	18.1	4000	90	X Cone	1653-2037	3 50°		
					Y Glass	1071-1360			
 Max. 235 Ø55 130									

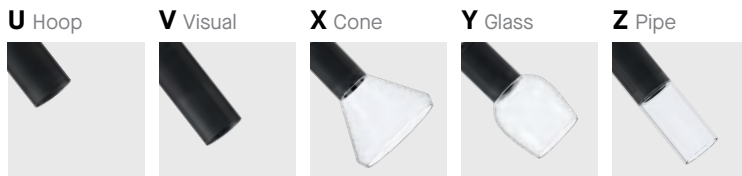

AV13 - Driver remote (except 6W/12W on/off built-in)
 AV28 - Driver built-in

Finishes / Finitions

Selection of finishes available on the online configurator
 Sélection de finitions disponibles grâce au configurateur en ligne



Configurator
Configurateur
iris.ledsc4.com



Lens accessories

Accessoires optiques

	Elliptical diffuser (5u.) Diffuseur elliptique (5 u.)	71-5167-00-00		Panel de abeja (5u.) Painel de abelha (5u.)	71-5166-60-00
	Square diffuser (5u.) Diffuseur carré (5 u.)	71-5658-00-00		Apantallador (5u.) Obturador assimetrico (5u.)	71-7895-60-00
	Halo fader (5u.) Diffuseur de halo (5 u.)	71-6099-00-00			

Leco



Ceiling light that can be used in standard or emergency format
 Plafonnier pouvant être utilisé dans sa forme standard ou de sécurité

Leco

BODY MAT PC	DIF MAT PC		3 MacAdam	IP 44	IK 10	LOW FLICKER		
----------------	---------------	-------------------------------------------------------------------------------------	--------------	----------	----------	----------------	---------------------------------------------------------------------------------------	---------------------------------------------------------------------------------------

○
14

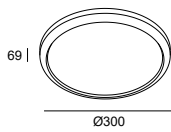

LED						
K	CRI	W Total	Real Lm	Code		
4000	80	10	911	15-A003 - 14 - OU	ON-OFF	220-240V

 **Leco Emergency**
 ⓘ P. 941

Luno Slim

Designed by LedsC4 Architectural

Pendant
P. 264

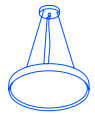

INDOOR



+ Luno Slim



Skylight effect Effet de lucarne

Luno Slim blends seamlessly into the space thanks to its curved profile, delivering high-quality light that creates a skylight effect.

Luno Slim se fond dans l'espace de manière subtile grâce à son profil incurvé, offrant un éclairage de qualité qui évoque l'effet d'une lucarne.

SPOTLIGHTS / CEILINGS | PROJECTEURS / PLAFONNIERS



Two finishes and four sizes to adapt to all projects Deux finitions et quatre tailles pour s'adapter à tous les projets



UGR<19.
UGR<19.

Efficiency up to 121 Lm/W Efficacité jusqu'à 121 Lm/W

High efficiency micro-prismatic diffuser.
Diffuseur microprismatique à haute efficacité.



Luno Slim Small

BODY MAT	DIF MAT		50000h	3	IP	UGR		
AL	PC		L80 B20	MacAdam	20	<19		

Code example / Exemple d'élaboration d'une référence: **AR11-27W9MPDS14**

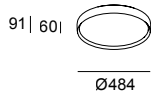

K	W	CRI	Optics	Real Lm	Code	Finishes
3000	27.8	90	Microprisma	3037	AR11-27W9MPDSXX	14 ○ ON-OFF/DALI-2/
4000	27.8	90	Microprisma	3158	AR11-27X9MPDSXX	60 ● PUSH 220-240V

Luno Slim Medium

BODY MAT	DIF MAT		50000h	3	IP	UGR		
AL	PC		L80 B20	MacAdam	20	<19		

Code example / Exemple d'élaboration d'une référence: **AR12-37W9MPDS14**

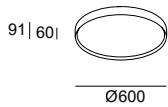

K	W	CRI	Optics	Real Lm	Code	Finishes
3000	37.8	90	Microprisma	3956	AR12-37W9MPDSXX	14 ○ ON-OFF/DALI-2/
4000	37.8	90	Microprisma	4114	AR12-37X9MPDSXX	60 ● PUSH 220-240V

Luno Slim Large

BODY MAT	DIF MAT		50000h	3	IP	UGR		
AL	PC		L80 B20	MacAdam	20	<16		

Code example / Exemple d'élaboration d'une référence: **AR13-72W9MPDS14**

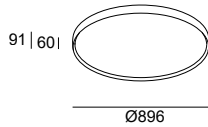

K	W	CRI	Optics	Real Lm	Code	Finishes
3000	71.3	90	Microprisma	6917	AR13-72W9MPDSXX	14 ○ ON-OFF/DALI-2/
4000	71.3	90	Microprisma	7194	AR13-72X9MPDSXX	60 ● PUSH 220-240V

Luno Slim Extra Large

BODY MAT	DIF MAT		50000h	3	IP	UGR		
AL	PC		L80 B20	MacAdam	20	<19		

Code example / Exemple d'élaboration d'une référence: **AR14-CPW9MPDS14**

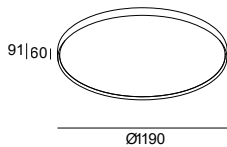

K	W	CRI	Optics	Real Lm	Code	Finishes
3000	108.2	90	Microprisma	9863	AR14-CPW9MPDSXX	14 ○ ON-OFF/DALI-2/
4000	108.2	90	Microprisma	10257	AR14-CPX9MPDSXX	60 ● PUSH 220-240V

XX= Replace for finish code: 14 or 60



Collection made from plaster, perfect for general indoor lighting where full integration with the space is sought
Fabriquée en plâtre, cette collection est idéale pour l'éclairage général d'intérieurs avec intégration totale dans l'espace

Ges Surfacé Round

BODY MAT
PLSTER



IP
23

○
14

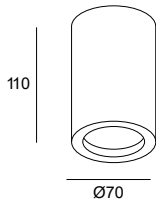

GU10

W

Max. 8

Code

15-5946 - 14 - 00



+ Play

Downlights
P. 184



Track
P. 096



Pendant
P. 271



Spotlight
P. 283



Efficiency and comfort Efficacité et confort

All the technical features of the Play collection in a Surface version, ideal for projects requiring superior efficiency and comfort.

Toutes les prestations techniques de la collection Play en une version Surface, idéale pour les projets qui exigent un plus d'efficacité et de confort.

Play Deco Spotlight

	2 MacAdam	IP 20	BODY MAT AL	DIF MAT PMMA	UGR <19		
--	--------------	----------	----------------	-----------------	------------	--	--

Code exemple / Exemple d'élaboration d'une référence: **AG69-P7V9S20UWG**

Model	W	K	CRI	Real Lm	Optics	Source	Finishes
<p>AG69 - Round Surface</p>	P7V9	6.4	2700	90	521-554	S2 15° OU ON-OFF 100-240V	WG
	P7W9	6.4	3000	90	604-642	M2 28° TS PHASE CUT 220-240V	WH
	P7X9	6.4	4000	90	604-646	F1 49° DU DALI-2 110-277V	WL
	13V9	11.9	2700	80	1070-1167	S2 20° OU ON-OFF 100-240V	WM
	13W9	11.9	3000	80	1152-1276	M2 33° TS PHASE CUT 220-240V	WN
	13X9	11.9	4000	80	1233-1344	F1 44° DU DALI-2 110-240V	WR

Play Deco Surface

	2 MacAdam	IP 23	BODY MAT AL	DIF MAT PMMA	UGR <19		
--	--------------	----------	----------------	-----------------	------------	--	--

Code exemple / Exemple d'élaboration d'une référence: **AG32-P7V9S20UWR**

Model	W	K	CRI	Real Lm	Optics	Source	Finishes
<p>AG32 - Round Fixed</p>	P7V9	6.4	2700	90	521-554	S2 15° OU ON-OFF 100-240V	WG
	P7W9	6.4	3000	90	604-642	M2 28° TS PHASE CUT 220-240V	WH
	P7X9	6.4	4000	90	604-642	F1 49° DU DALI-2 110-277V	WL
	13V9	11.9	2700	90	1070-1167	S2 20° OU ON-OFF 100-240V	WM
	13W9	11.9	3000	90	1152-1276	M2 33° TS PHASE CUT 220-240V	WN
	13X9	11.9	4000	90	1233-1344	F1 44° DU DALI-2 110-277V	WR

Exit



High visual comfort
with a UGR < 19
Grand confort visuel
avec UGR < 19

A cylindrical ceiling light with internal technology designed to offer high colour rendering in spaces and products with a CRI80-CRI90, along with minimal glare and high visual comfort thanks to a UGR<19.

Plafonnier cylindrique dont la technologie intérieure est conçue pour offrir un haut rendu de couleurs des espaces et des produits grâce à un IRC 80/90, un éblouissement minimum et un confort visuel élevé grâce à un UGR < 19.

Exit

BODY MAT	DIF MAT	2	50000h	IP	UGR		
AL	PC	MacAdam	L80 B20	23	<19		

○ ●
14 60

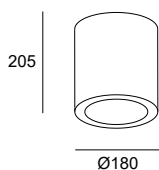

LED							
K	CRI	W Total	Real Lm	Optics	Code		
3000	80	26.9	2284	38°	90-3208	14 - OU	ON-OFF 100-240V
						60 - DU	DALI-2/PUSH 100-240V
3000	80	37.4	2646	38°	90-3210	14 - OU	ON-OFF 100-240V
						60 - DU	DALI-2/PUSH 100-240V
3000	90	26.9	1728	38°	90-3529	14 - OU	ON-OFF 100-240V
						60 - DU	DALI-2/PUSH 100-240V
3000	90	37.4	2347	38°	90-3530	14 - OU	ON-OFF 100-240V
						60 - DU	DALI-2/PUSH 100-240V
4000	80	26.9	2284	38°	90-3209	14 - OU	ON-OFF 100-240V
						60 - DU	DALI-2/PUSH 100-240V
4000	80	37.4	2646	38°	90-3211	14 - OU	ON-OFF 100-240V
						60 - DU	DALI-2/PUSH 100-240V

Fixing accessories

Accessoires de fixation



Suspension kit
Kit de suspension

14 ○ **71-3223-14-00**

60 ● **71-3223-60-00**

Connection accessories

Accessoires de connexion



Track connector
Connecteur de rail

71-3531-60-00

Connective controllers

Contrôleurs connectés



Consult the available control systems / Consultez les systèmes de contrôle disponibles:

DALI2 / DALI2

Bluetooth wireless / Sans fil Bluetooth

DMX / DMX

Autonomous / Autonome

P. 969

Multidir Evo

Designed by LedsC4 Architectural

Downlights
P. 247



INDOOR



+ Multidir Evo



Surface-mounted cardan-type collection. Ideal for retail applications, both the single and double versions have a mechanical rotation system that allows the light to be directed to any point and are available with a black interior in all versions for greater integration and comfort.

Collecteur de type cardan monté en surface. Idéales pour les applications de vente au détail, les versions simple et double sont dotées d'un système de rotation mécanique qui permet de diriger la lumière vers n'importe quel point et sont disponibles avec un intérieur noir dans toutes les versions pour une meilleure intégration et un plus grand confort.

SPOTLIGHTS / CEILINGS | PROJECTEURS / PLAFONNIERS



Multidir Evo Surface Small Single

BODY MAT	DIF MAT	50000h	2	IP	
AL	PC	L80 B20	MacAdam	120	40°

Code exemple / Exemple d'élaboration d'une référence: **AU16-P8V9S30S60**

Model		W	K	CRI	Optics	Real Lm	Source	Finishes
AU15 - Single / Surface 	P8V9	8.2	2700	90	S3 17°	967 - 1027	OS ON-OFF 220-240V	14
	P8W9	8.2	3000	90	M3 38°	965 - 1025	DU DALI-2 100-240V	34
	P8X9	8.2	4000	90	F1 64°	964 - 1024	BB 36V/max.250mA	60
	11V9	11.8	2700	90	S3 18°	1312 - 1394	OS ON-OFF 220-240V	
	11W9	11.8	3000	90	M3 38°	1310 - 1392	DU DALI-2 100-240V	
	11X9	11.8	4000	90	F1 64°	1308 - 1390	BB 36V/max.350mA	
	18V9	17.3	2700	90	S3 18°	1792 - 1904	OS ON-OFF 220-240V	
	18W9	17.3	3000	90	M3 38°	1794 - 1906	DU DALI-2 100-240V	
	18X9	17.3	4000	90	F1 64°	1798 - 1910	BB 36V/max.500mA	
	AAG1	Max. 8	GU10		NA		BU 100-240V	

Multidir Evo Surface Small Double

BODY MAT	DIF MAT	50000h	2	IP	
AL	PC	L80 B20	MacAdam	120	40°

Code exemple / Exemple d'élaboration d'une référence: **AU16-P8V9S30S60**

Model		W	K	CRI	Optics	Real Lm	Source	Finishes
AU16 - Double / Surface 	P8V9	17.3	2700	90	S3 17°	1934 - 2054	OS ON-OFF 220-240V	14
	P8W9	17.3	3000	90	M3 38°	1930 - 2050	DU DALI-2 100-240V	34
	P8X9	17.3	4000	90	F1 64°	1928 - 2048	BB 2x36V/max.250mA	60
	11V9	25.1	2700	90	S3 18°	2624 - 2788	OS ON-OFF 220-240V	
	11W9	25.1	3000	90	M3 38°	2620 - 2784	DU DALI-2 100-240V	
	11X9	25.1	4000	90	F1 64°	2616 - 2780	BB 2x36V/max.350mA	
	18V9	34.6	2700	90	S3 18°	3596 - 3820	OS ON-OFF 220-240V	
	18W9	34.6	3000	90	M3 38°	3588 - 3812	DU DALI-2 100-240V	
	18X9	34.6	4000	90	F1 64°	3584 - 3808	BB 2x36V/max.500mA	
	AAG1	2 x Max. 8	GU10		NA		BU 100-240V	

Multidir Evo Surface Big Single

BODY MAT	DIF MAT	50000h	2	IP	
AL	PC	L80 B20	MacAdam	120	40°

Code example / Exemple d'élaboration d'une référence: **AU22-18V9S30S14**

Model		W	K	CRI	Optics	Real Lm	Source	Finishes
AU22 - Single / Surface 	18V9	16.2	2700	90	S3 15°	2023 - 2150	OS ON-OFF 220-240V	14
	18W9	16.2	3000	90	M3 38°	1947 - 2069	DU DALI-2 100-240V	34
	18X9	16.2	4000	90	F1 63°	1961 - 2083	BB 36V/max.500mA	60
	25V9	23.1	2700	90	S3 14°	2770 - 2943	OU ON-OFF 220-240V	
	25W9	23.1	3000	90	M3 38°	2665 - 2832	DU DALI-2 100-240V	
	25X9	23.1	4000	90	F1 63°	2684 - 2852	BB 36V/max.700mA	
	33V9	30.3	2700	90	S3 14°	3462 - 3678	OS ON-OFF 220-240V	
	33W9	30.3	3000	90	M3 38°	3332 - 3678	DU DALI-2 100-240V	
	33X9	30.3	4000	90	F1 63°	3355 - 3564	BB 36V/max.900mA	
	39V9	41.4	2700	90	S3 15°	4431 - 4708	OS ON-OFF 220-240V	
	39W9	41.4	3000	90	M3 38°	4264 - 4531	DS DALI-2 220-240V	
	39X9	41.4	4000	90	F1 63°	4294 - 4562	BB 36V/max.1200mA	
AAG1	Max. 8	GU10		NA		BU 100-240V		

Multidir Evo Surface Big Double

BODY MAT	DIF MAT	50000h	2	IP	
AL	PC	L80 B20	MacAdam	120	40°

Code example / Exemple d'élaboration d'une référence: **AU23-18V9S30S14**

Model		W	K	CRI	Optics	Real Lm	Source	Finishes
AU23 - Double / Surface 	18V9	35.8	2700	90	S3 15°	4046 - 4300	OS ON-OFF 220-240V	14
	18W9	35.8	3000	90	M3 38°	3894 - 4138	DU DALI-2 100-240V	34
	18X9	35.8	4000	90	F1 63°	3922 - 4166	BB 2x36V/max.500mA	60
	25V9	49.1	2700	90	S3 14°	5540-5886	OU ON-OFF 220-240V	
	25W9	49.1	3000	90	M3 38°	5330 - 5664	DS DALI-2 220-240V	
	25X9	49.1	4000	90	F1 63°	5368 - 5704	BB 2x36V/max.700mA	
	33V9	60.6	2700	90	S3 14°	6994 - 7356	OS ON-OFF 220-240V	
	33W9	60.6	3000	90	M3 38°	6664 - 7080	DU DALI-2 100-240V	
	33X9	60.6	4000	90	F1 63°	6710 - 7128	BB 2x36V/max.900mA	
	39V9	82.8	2700	90	S3 15°	8862 - 9416	OS ON-OFF 220-240V	
	39W9	82.8	3000	90	M3 38°	8528 - 9062	DS DALI-2 220-240V	
	39X9	82.8	4000	90	F1 63°	8588 - 9124	BB 2x36V/max.1200mA	
AAG1	2 x Max 8.	GU10		NA		BU 100-240V		

Multidir Small
Ceiling

Multidir Big
Ceiling

Lens accessories Accessoires optiques



Honeycomb panel (5u.)
Grille en nid d'abeille (5 u.)

71-A854-60-00

71-A855-60-00

Atom

Designed by LedsC4 Architectural



+ Atom

Track
P. 078



Low Voltage
P. 114



Recessed
P. 306



Hide
P. 300



Surface and recessed options Options de surface et encastrées

A versatile collection of spotlights featuring a pure and compact design, offering a range of applications, finishes and sizes. Its technical solutions ensure optimal control of the angle range, providing precise lighting for both the object and the illuminated space.

Collection polyvalente de projecteurs au design épuré et compact, qui offre une grande variété d'applications, de finitions et de tailles. Ses solutions techniques permettent un contrôle optimal de la gamme d'angles pour garantir une grande précision d'éclairage sur l'objet et l'espace à éclairer.

Various finishes are available to suit project requirements
Différents effets pour répondre aux besoins du projet





Colour quality. Atom enhances the chromatic range of illuminated objects with a CRI90

Qualité de rendu des couleurs. Atom renforce le rendu des couleurs des objets qu'il éclaire grâce à un IRC de 90



Efficiency and visual comfort Efficacité et confort visuel

Thanks to a specific development for the lens combined with a high-efficiency LED bulb, Atom offers an angle of only 8° of aperture among its options. The result is an accent light with smooth, even contours.

Grâce à un développement spécifique de la lentille combiné à une LED à haute efficacité, Atom offre parmi ses options un angle d'ouverture de seulement 8°. Le résultat est un éclairage d'accentuation aux contours lisses et uniformes.



8° controlled angle Angle contrôlé de 8°



Atom Surface

Designed by LedsC4 Architectural



With the option of a single or double spot, Atom is available in various sizes, apertures and colour temperatures, along with different optical accessories to ensure precise lighting in the project.

En option spot simple ou double, Atom dispose de différentes tailles, ouvertures et températures de couleur, ainsi que de plusieurs accessoires optiques pour assurer une précision lumineuse optimale dans le cadre du projet.



Comfortable lighting thanks to its lens design that achieves high efficiency and glare control
Lumière confortable grâce à la conception de ses optiques qui assurent une grande efficacité et le contrôle de l'éblouissement

Manual zoom Zoom manuel

System that allows you to quickly and conveniently control the light beam's angle of aperture from 16° to 47°.

Système qui permet de contrôler l'angle d'ouverture du faisceau de 16° à 47° de façon rapide et pratique.

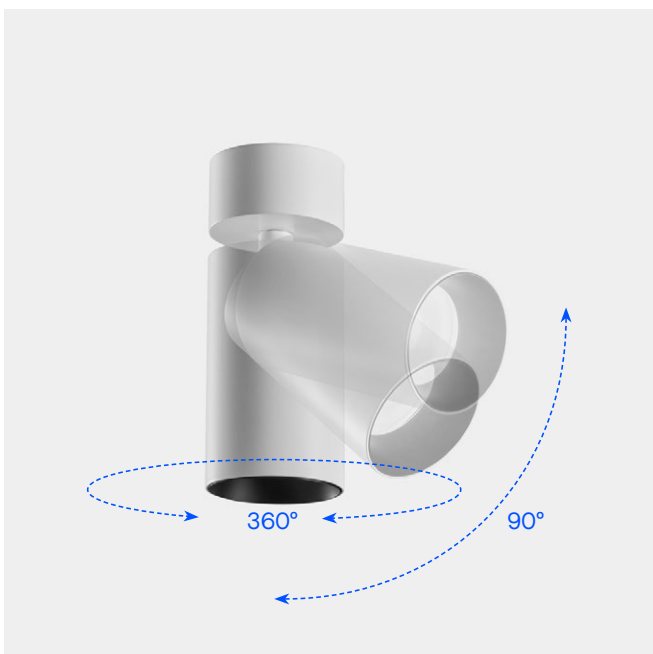
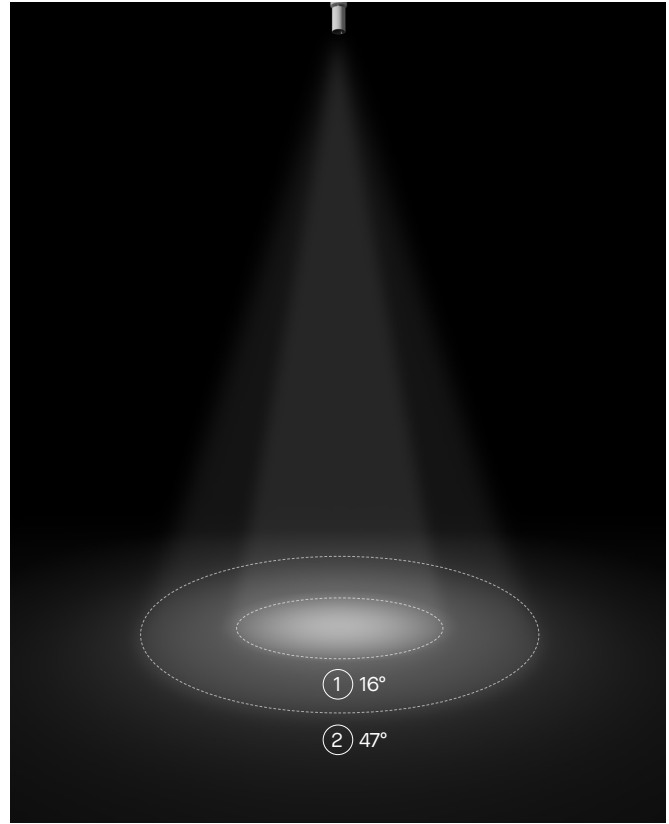

Offers a 360° rotation in the horizontal plane and a 90° tilt in the vertical plane

Permet une rotation de 360° à l'horizontale et une inclinaison de 90° à la verticale

Double spot ceiling fixture that allows convenient directing of the light beam towards the desired points
Plafonnier à double spot qui permet de diriger confortablement le faisceau lumineux vers les points nécessaires





Atom Surface
Ø52
120V*

BODY MAT	2	IP	DIF MAT	50000h		WELL				
AL	MacAdam	20	PC	L80 B20			320°	90°		

14 60 81 DN

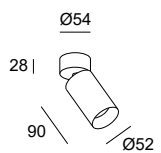

LED						
K	CRI	W Total	Real Lm	Optics	Code	
3000	90	7.5	325	24°	15-6485	14
3000	90	7.5	308	33°	15-6486	60 - ML
3000	90	7.5	245	43°	15-6487	81 DN

PHASE CUT 120V

* Not Suitable For The European Market
* Ne Convient Pas Au Marché Européen

Atom Surface
Ø75
120V*

BODY MAT	2	IP	DIF MAT	50000h		WELL				
AL	MacAdam	20	PC	L80 B20			320°	90°		

14 60

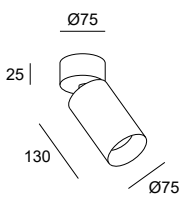

LED						
K	CRI	W Total	Real Lm	Optics	Code	
3000	90	14.3	916	22°	15-6282	14
3000	90	14.3	870	31°	15-6283	60 - ML
3000	90	14.3	692	39°	15-6284	ON-OFF 120V

* Not Suitable For The European Market
* Ne Convient Pas Au Marché Européen

Atom Surface
Ø52

BODY MAT	2	IP	DIF MAT	50000h		WELL				
AL	MacAdam	20	PC	L80 B20			320°	90°		

14 60 81 DN

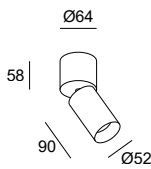

LED						
K	CRI	W Total	Real Lm	Optics	Code	
2700	90	10.5	428	8°	15-A095	14
2700	90	14.3	1153	22°	15-A065	60 - TS
2700	90	14.3	1289	35°	15-A066	81 - TS
2700	90	14.3	1264	43°	15-A067	DN
3000	90	10.5	437	8°	15-A096	14
3000	90	14.3	1200	22°	15-A068	60 - TS
3000	90	14.3	1342	35°	15-A069	81 - TS
3000	90	14.3	1316	43°	15-A070	DN
4000	90	10.5	459	8°	5-A097	14
4000	90	14.3	1219	22°	15-A071	60 - TS
4000	90	14.3	1363	35°	15-A072	81 - TS
4000	90	14.3	1335	43°	15-A073	DN

PHASE CUT 220-240V

Atom Surface
Ø52 Zoom

BODY MAT	2	IP	DIF MAT	LOW	50000h					
AL	MacAdam	20	PC	FLICKER	L80 B20		320°	90°		

14 60

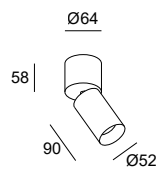

LED						
K	CRI	W Total	Real Lm	Optics	Code	
2700	90	15.3	1113	Zoom 16°-47°	15-A098	14 - TS
3000	90	15.3	1180	Zoom 16°-47°	15-A099	60 - TS
4000	90	15.3	1263	Zoom 16°-47°	15-A100	81 - TS

PHASE CUT 220-240V

Atom Surface
Ø75
36V / 350mA

BODY MAT	2	IP	DIF MAT	50000h	90°	320°	LED	DRIVER
AL	MacAdam	20	PC	L80 B20				

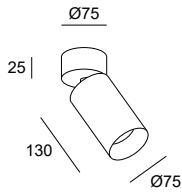

○ ●
14 60

LED							max.350mA 36V	
K	CRI	W	Real Lm	Optics	Code			
2700	90	13.5	1634	16°	15-A018	14	-	00
3000	90	13.5	1667	16°	15-A019	14	-	00
4000	90	13.5	1751	16°	15-A020	14	-	00

Atom Surface
Ø75
36V / 700mA

BODY MAT	2	IP	WELL	50000h	320°	90°	LED	DRIVER
AL	MacAdam	20		L80 B20				

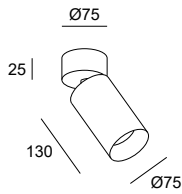
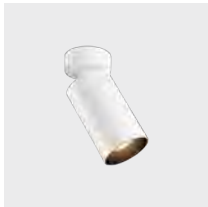

○ ●
14 60

LED							max.700mA 36V	
K	CRI	W	Real Lm	Optics	Code			
2700	90	23.1	2333	24°	15-7305			
2700	90	23.1	2237	31°	15-7306	14	-	00
2700	90	23.1	2243	37°	15-7307	60	-	00
3000	90	23.1	2430	24°	15-7308			
3000	90	23.1	2331	31°	15-7309	14	-	00
3000	90	23.1	2336	37°	15-7310	60	-	00
4000	90	23.1	2466	24°	15-A024			
4000	90	23.1	2366	31°	15-A025	14	-	00
4000	90	23.1	2372	37°	15-A026	60	-	00

Remote Driver

Atom Surface
Ø75
36V / 1050mA

BODY MAT	2	IP	WELL	50000h	320°	90°	LED	DRIVER
AL	MacAdam	20		L80 B20				

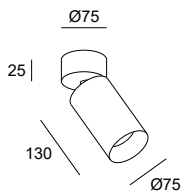
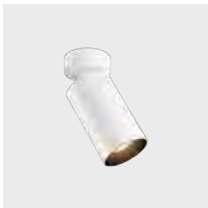

○ ●
14 60

LED							max.1050mA 36V	
K	CRI	W	Real Lm	Optics	Code			
2700	90	32.1	3247	24°	15-A178			
2700	90	32.1	3178	31°	15-A179	14	-	00
2700	90	32.1	3189	37°	15-A180	60	-	00
3000	90	32.1	3383	24°	15-A181			
3000	90	32.1	3310	31°	15-A182	14	-	00
3000	90	32.1	3323	37°	15-A183	60	-	00
4000	90	32.1	3433	24°	15-A184			
4000	90	32.1	3359	31°	15-A185	14	-	00
4000	90	32.1	3373	37°	15-A186	60	-	00

Remote Driver

Atom Surface
Ø75

BODY MAT
AL

2
MacAdam

IP
20



WELL

320°

90°

50000h
L80 B20



○ ●
14 60

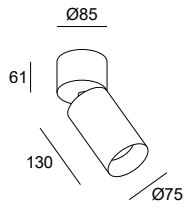

LED									
K	CRI	W Total	Real Lm	Optics	Code				
2700	90	26.7	2333	24°	15-A083	14	TS	PHASE CUT	220-240V
2700	90	26.7	2237	31°	15-A084	60	DU	DALI-2	120-240V
2700	90	26.7	2243	37°	15-A085				
2700	90	35.8	3247	24°	15-A169	14	TS	PHASE CUT	220-240V
2700	90	35.8	3178	31°	15-A170	60	DU	DALI-2	120-240V
2700	90	35.8	3189	37°	15-A171				
2700	90	16	1634	16°	15-A092	14	DU	DALI-2	120-240V
						60			
3000	90	26.7	2430	24°	15-A086	14	TS	PHASE CUT	220-240V
3000	90	26.7	2331	31°	15-A087	60	DU	DALI-2	120-240V
3000	90	26.7	2336	37°	15-A088				
3000	90	35.8	3383	24°	15-A172	14	TS	PHASE CUT	220-240V
3000	90	35.8	3310	31°	15-A173	60	DU	DALI-2	120-240V
3000	90	35.8	3323	37°	15-A174				
3000	90	16	1667	16°	15-A093	14	DU	DALI-2	120-240V
						60			
4000	90	26.7	2466	24°	15-A080	14	TS	PHASE CUT	220-240V
4000	90	26.7	2366	31°	15-A081	60	DU	DALI-2	120-240V
4000	90	26.7	2372	37°	15-A082				
4000	90	35.8	3433	24°	15-A175	14	TS	PHASE CUT	220-240V
4000	90	35.8	3359	31°	15-A176	60	DU	DALI-2	120-240V
4000	90	35.8	3373	37°	15-A177				
4000	90	16	1751	16°	15-A094	14	DU	DALI-2	120-240V
						60			

Atom Surface Double Ø52

	IP 20	BODY MAT AL	2 MacAdam	 320°	DIF MAT PC	 90°	50000h L80 B20		
--	----------	----------------	--------------	----------	---------------	---------	-------------------	--	--

○ ●
14 60

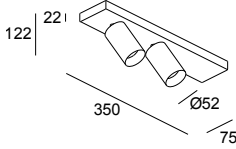

LED									
K	CRI	W Total	Real Lm	Optics	Code				
2700	90	26	2308	22°	15-A187	-	14	OS	ON-OFF 220-240V
2700	90	26	2580	35°	15-A188	-	60	DS	DALI-2 / PUSH 220-240V
2700	90	26	2530	43°	15-A189				
2700	90	38.1	3098	22°	15-A199	-	14	OS	ON-OFF 220-240V
2700	90	38.1	3536	35°	15-A200	-	60	DS	DALI-2 / PUSH 220-240V
2700	90	38.1	3430	43°	15-A201				
3000	90	26	2400	22°	15-A191	-	14	OS	ON-OFF 220-240V
3000	90	26	2684	35°	15-A192	-	60	DS	DALI-2 / PUSH 220-240V
3000	90	26	2632	43°	15-A193				
3000	90	38.1	3220	22°	15-A203	-	14	OS	ON-OFF 220-240V
3000	90	38.1	3676	35°	15-A204	-	60	DS	DALI-2 / PUSH 220-240V
3000	90	38.1	3566	43°	15-A205				
4000	90	26	2666	22°	15-A195	-	14	OS	ON-OFF 220-240V
4000	90	26	2984	35°	15-A196	-	60	DS	DALI-2 / PUSH 220-240V
4000	90	26	2924	43°	15-A197				
4000	90	38.1	3580	22°	15-A207	-	14	OS	ON-OFF 220-240V
4000	90	38.1	4086	35°	15-A208	-	60	DS	DALI-2 / PUSH 220-240V
4000	90	38.1	3962	43°	15-A209				

Atom Double Spot Zoom

	IP 20	BODY MAT AL	2 MacAdam	 320°	DIF MAT PC	 90°	50000h L80 B20		
--	----------	----------------	--------------	----------	---------------	---------	-------------------	--	--

○ ●
14 60

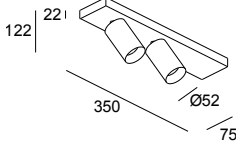

LED									
K	CRI	W Total	Real Lm	Optics	Code				
2700	90	27.7	2206	Zoom 16°-45°	15-A190	-	14	OS	ON-OFF 220-240V
						-	60	DS	DALI-2 / PUSH 220-240V
3000	90	27.7	2362	Zoom 16°-45°	15-A194	-	14	OS	ON-OFF 220-240V
						-	60	DS	DALI-2 / PUSH 220-240V
4000	90	27.7	2526	Zoom 16°-45°	15-A198	-	14	OS	ON-OFF 220-240V
						-	60	DS	DALI-2 / PUSH 220-240V

Atom Surface Ø52 Single & Double	Atom Surface Ø75	Atom Surface Ø75 36V 350mA	Atom Surface Ø75 36V 700mA	Atom Surface Ø75 36V 1050mA

Drivers
Drivers

P. 984

	ON-OFF IP20	-	-	71-6652-00-00	71-6653-00-00	71-6661-00-00
	PHASE CUT 240V IP20	-	-	71-A297-00-00	71-A299-00-00	-
	DALI2 PUSH IP20	-	-	71-A191-00-00	71-A192-00-00	71-A303-00-00

Lens accessories
Accessoires optiques

	Elliptical diffuser (5u.) Diffuseur elliptique (5 u.)		71-6274-00-00	71-6280-00-00	71-6280-00-00	71-6280-00-00	71-6280-00-00	71-6280-00-00
	Halo fader (5u.) Diffuseur de halo (5 u.)		71-6275-00-00	71-6281-00-00	71-6281-00-00	71-6281-00-00	71-6281-00-00	71-6281-00-00
	Visual comfort (1u.) Confort visuel (1 u.)	14 ○	71-6276-14-00	71-6282-14-00	71-6282-14-00	71-6282-14-00	71-6282-14-00	71-6282-14-00
		60 ●	71-6276-60-00	71-6282-60-00	71-6282-60-00	71-6282-60-00	71-6282-60-00	71-6282-60-00
	Honeycomb panel (5u.) Grille en nid d'abeille (5 u.)	60 ●	71-6273-60-00	71-6279-60-00	71-6279-60-00	71-6279-60-00	71-6279-60-00	71-6279-60-00
	Visor Visière	60 ●	71-6277-60-00	71-6283-60-00	71-6283-60-00	71-6283-60-00	71-6283-60-00	71-6283-60-00
	Front ring Anneau frontal	14 ○	71-6436-14-00	71-6437-14-00	71-6437-14-00	71-6437-14-00	71-6437-14-00	71-6437-14-00
		23 ●	71-6436-23-00	71-6437-23-00	71-6437-23-00	71-6437-23-00	71-6437-23-00	71-6437-23-00

Zoom versions are not compatible with optical accessories.
Les versions Zoom ne sont pas compatibles avec les accessoires optiques.

Atom Hide

Designed by LedsC4 Architectural



An in-out spotlight with three sizes and various finishes to seamlessly adapt to spaces

Projecteur in-out qui se décline en trois tailles et en plusieurs finitions pour s'adapter facilement aux espaces

Switch from downlight to spotlight in a single step
Passe du mode downlight à projecteur en une seule étape

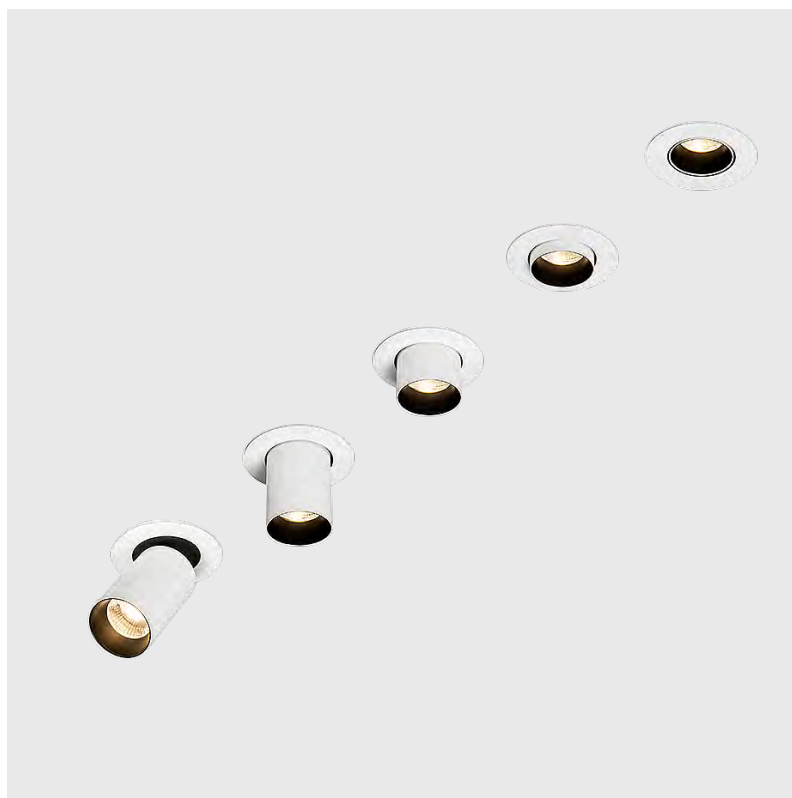



**Atom Hide
Ø30
9V/350mA**

BODY MAT	2	IP		WELL				50000h		
AL	MacAdam	20								

14 60

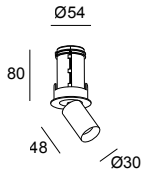

Ø 48 0-18 mm

LED							max.350mA 9V	
K	CRI	W	Real Lm	Optics	Code			
2700	90	3.1	269	37°	90-8013	14	60	- 00
3000	90	3.1	364	37°	90-8014	14	60	- 00

**Atom Hide
Ø52
Narrow**

BODY MAT	2	IP		WELL				50000h		
AL	MacAdam	20								

14 60 81 DN

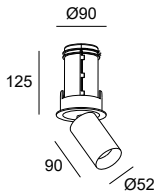

Ø 80 0-20 mm

LED							max.700mA 12V	
K	CRI	W	Real Lm	Optics	Code			
2700	90	8.2	428	8°	90-A021	14	60	- 00
						81	DN	
3000	90	8.2	437	8°	90-A038	14	60	- 00
						81	DN	
4000	90	8.2	459	8°	90-A039	14	60	- 00
						81	DN	

**Atom Hide
Ø52
36V/350mA**

BODY MAT	2	IP		WELL				50000h		
AL	MacAdam	0								

14 60 81 DN

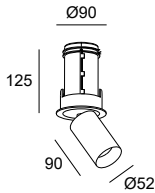

Ø 80 0-20 mm

LED							max.350mA 36V	
K	CRI	W	Real Lm	Optics	Code			
2700	90	12	1153	22°	90-7273	14		
2700	90	12	1289	35°	90-7274	60	81	- 00
2700	90	12	1264	43°	90-7275	81	DN	
3000	90	12	1200	22°	90-7276	14		
3000	90	12	1342	35°	90-7277	60	81	- 00
3000	90	12	1316	43°	90-7278	81	DN	
4000	90	12	1219	22°	90-A003	14		
4000	90	12	1363	35°	90-A004	60	81	- 00
4000	90	12	1335	43°	90-A005	81	DN	

Atom Hide Ø52 Zoom

BODY MAT	2	IP		WELL		90°	320°	50000h L80 B20		
AL	MacAdam	20								

○ ●
14 60

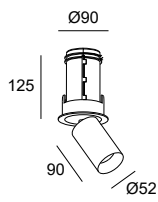

80 0-20 mm



LED							max.350mA 36V	
K	CRI	W	Real Lm	Optics	Code			
2700	90	12.5	1093	Zoom 16°-47°	90-A060	14	60	- 00
3000	90	12.5	1159	Zoom 16°-47°	90-A061	14	60	- 00
4000	90	12.5	1241	Zoom 16°-47°	90-A062	14	60	- 00

Atom Hide Ø52 36V/500mA

BODY MAT	2	IP		WELL		90°	320°	50000h L80 B20		
AL	MacAdam	0								

○ ● ● ●
14 60 81 DN

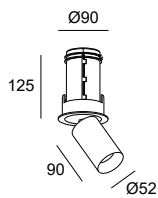

80 0-20 mm

LED							max.500mA 36V	
K	CRI	W	Real Lm	Optics	Code			
2700	90	17.7	1547	22°	90-A152	14	60	- 00
2700	90	17.7	1766	35°	90-A153	81	81	- 00
2700	90	17.7	1713	43°	90-A154	DN	DN	- 00
3000	90	17.7	1610	22°	90-A155	14	60	- 00
3000	90	17.7	1838	35°	90-A156	81	81	- 00
3000	90	17.7	1783	43°	90-A157	DN	DN	- 00
4000	90	17.7	1635	22°	90-A158	14	60	- 00
4000	90	17.7	1867	35°	90-A159	81	81	- 00
4000	90	17.7	1811	43°	90-A160	DN	DN	- 00

Atom Hide
Ø75
Narrow

BODY MAT	2	IP		WELL			50000h		
AL	MacAdam	20							

○ ●
14 60

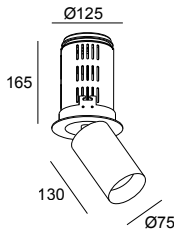

110 0-20 mm

LED							max.350mA 36V	
K	CRI	W	Real Lm	Optics	Code			
2700	90	13.5	1634	16°	90-A040 - 14 - 00 60			
3000	90	13.5	1667	16°	90-A019 - 14 - 00 60			
4000	90	13.5	1751	16°	90-A041 - 14 - 00 60			

Atom Hide
Ø75
36V/700mA

BODY MAT	2	IP		WELL			50000h		
AL	MacAdam	20							

○ ●
14 60

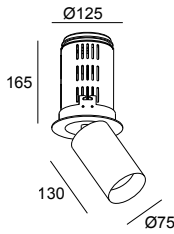

110 0-18 mm

LED							max.700mA 36V	
K	CRI	W	Real Lm	Optics	Code			
2700	90	23.7	2333	24°	90-8007			
2700	90	23.7	2237	31°	90-8008 - 14 - 00 60			
2700	90	23.7	2243	37°	90-8009			
3000	90	23.1	2430	24°	90-8010			
3000	90	23.1	2331	31°	90-8011 - 14 - 00 60			
3000	90	23.1	2336	37°	90-8012			
4000	90	23.7	2466	24°	90-A009			
4000	90	23.7	2366	31°	90-A010 - 14 - 00 60			
4000	90	23.7	2372	37°	90-A011			

Atom Hide
Ø75 36V
36V/1050mA

BODY MAT	2	IP		WELL			50000h		
AL	MacAdam	0							

○ ●
14 60

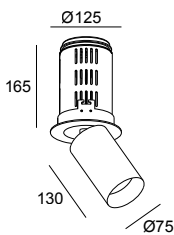



110 0-20 mm

LED							max.1050mA 36V	
K	CRI	W	Real Lm	Optics	Code			
2700	90	36.6	3247	24°	90-A161			
2700	90	36.6	3178	31°	90-A162 - 14 - 00 60			
2700	90	36.6	3189	47°	90-A163			
3000	90	36.6	3383	24°	90-A164			
3000	90	36.6	3310	31°	90-A165 - 14 - 00 60			
3000	90	36.6	3323	47°	90-A166			
4000	90	36.6	3433	24°	90-A167			
4000	90	36.6	3359	31°	90-A168 - 14 - 00 60			
4000	90	36.6	3373	47°	90-A169			







Atom Hide Ø30	Atom Hide / Zoom Ø52	Atom Hide Ø52 Narrow	Atom Hide Ø52 36V	Atom Hide Ø75	Atom Hide Ø75 Narrow	Atom Hide Ø75 36V
						

Drivers

P. 984

Drivers		71-B681-00-00	71-6652-00-00	71-B232-00-00	71-7551-00-00	71-6653-00-00	71-6652-00-00	71-6661-00-00
 ON-OFF IP20								
 PHASE CUT 240V PUSH IP20	71-4898-00-00 Min.1-Max.5	71-A297-00-00	71-7663-00-00	71-A298-00-00	71-A299-00-00	71-A297-00-00	-	
 DALI2 IP20	71-B407-00-00 Min.2 - Max.4	71-A191-00-00	71-A190-00-00	71-A192-00-00	71-A192-00-00	71-A191-00-00	71-A303-00-00	

Lens accessories
Accessoires optiques

 Elliptical diffuser (5u.) Diffuseur elliptique (5 u.)	-	71-6274-00-00*	71-6274-00-00	71-6274-00-00	71-6280-00-00	71-6280-00-00	71-6280-00-00
 Halo fader (5u.) Diffuseur de halo (5 u.)	-	71-6275-00-00*	71-6275-00-00	71-6275-00-00	71-6281-00-00	71-6281-00-00	71-6281-00-00
 Visual comfort (1u.) Confort visuel (1 u.)	14 ○	-	71-6276-14-00*	71-6276-14-00	71-6276-14-00	71-6282-14-00	71-6282-14-00
	60 ●	-	71-6276-60-00*	71-6276-60-00	71-6276-60-00	71-6282-60-00	71-6282-60-00
 Honeycomb panel (5u.) Grille en nid d'abeille (5 u.)	60 ●	-	71-6273-60-00*	71-6273-60-00	71-6273-60-00	71-6279-60-00	71-6279-60-00
 Visor Visière	60 ●	-	71-6277-60-00*	71-6277-60-00	71-6277-60-00	71-6283-60-00	71-6283-60-00
 Front ring Anneau frontal	14 ○	-	71-6436-14-00*	71-6436-14-00	71-6436-14-00	71-6437-14-00	71-6437-14-00
	23 ●	-	71-6436-23-00*	71-6436-23-00	71-6436-23-00	71-6437-23-00	71-6437-23-00

*Zoom versions are not compatible with optical accessories.
*Les versions Zoom ne sont pas compatibles avec les accessoires optiques.

Atom

Designed by LedsC4 Architectural



All the advantages of the Atom Collection in the recessed option
Tous les avantages de la collection Atom dans l'option Recessed

Atom Recessed Ø30 9V/350mA

BODY MAT	2	IP	DIF MAT				
AL	MacAdam	20	PC				

○ ● ● ●
14 60 81 DN

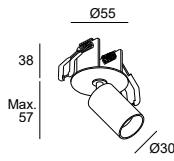
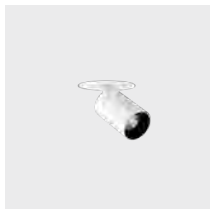

Ø 48 0-18 mm

LED						max.350mA 9V
K	CRI	W	Real Lm	Optics	Code	
2700	90	3.1	269	37°	35-A139 -	14
						60 - 00
						81
						DN
3000	90	3.1	364	37°	35-A140 -	14
						60 - 00
						81
						DN

Atom Recessed Ø52 12V/700mA

BODY MAT	2	IP	DIF MAT				
AL	MacAdam	20	PC				

○ ● ● ●
14 60 81 DN

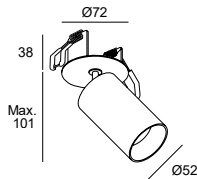

Ø 65 0-20 mm

LED						max.700mA 12V
K	CRI	W	Real Lm	Optics	Code	
2700	90	8.2	428	8°	35-A141 -	14
						60 - 00
						81
						DN
3000	90	8.2	437	8°	35-A146 -	14
						60 - 00
						81
						DN
4000	90	8.2	459	8°	35-A151 -	14
						60 - 00
						81
						DN

**Atom Recessed
Ø52
36V/350mA**

BODY MAT
AL

2
MacAdam

IP
20

DIF MAT
PC



14 60 81 DN

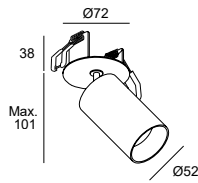

65 0-20 mm

LED						max.350mA 36V	
K	CRI	W	Real Lm	Optics	Code		
2700	90	11.8	1153	22°	35-A142	14	
2700	90	11.8	1289	35°	35-A143	60	- 00
2700	90	11.8	1264	43°	35-A144	81	- 00
						DN	
3000	90	11.8	1200	22°	35-A147	14	
3000	90	11.8	1342	35°	35-A148	60	- 00
3000	90	11.8	1316	43°	35-A149	81	- 00
						DN	
4000	90	11.8	1219	22°	35-A152	14	
4000	90	11.8	1363	35°	35-A153	60	- 00
4000	90	11.8	1335	43°	35-A154	81	- 00
						DN	

**Atom Recessed
Ø52
36V/500mA**

BODY MAT
AL

2
MacAdam

IP
20

DIF MAT
PC



14 60 81 DN

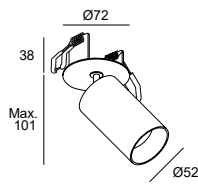

65 0-20 mm

LED						max.500mA 36V	
K	CRI	W	Real Lm	Optics	Code		
2700	90	17.3	1547	22°	35-A220	14	
2700	90	17.3	1766	35°	35-A221	60	- 00
2700	90	17.3	1713	43°	35-A222	81	- 00
						DN	
3000	90	17.3	1610	22°	35-A223	14	
3000	90	17.3	1838	35°	35-A224	60	- 00
3000	90	17.3	1783	43°	35-A225	81	- 00
						DN	
4000	90	17.3	1635	22°	35-A226	14	
4000	90	17.3	1867	35°	35-A227	60	- 00
4000	90	17.3	1811	43°	35-A228	81	- 00
						DN	

**Atom Recessed
Ø52 Zoom**

BODY MAT
AL

2
MacAdam

IP
20

DIF MAT
PC



14 60

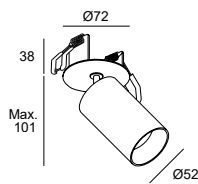

65 0-20 mm



LED						max.350mA 36V	
K	CRI	W	Real Lm	Optics	Code		
2700	90	12.6	1113	16°-47°	35-A145	14	- 00
						60	- 00
3000	90	12.6	1180	16°-47°	35-A150	14	- 00
						60	- 00
4000	90	12.6	1263	16°-47°	35-A155	14	- 00
						60	- 00

Atom Recessed Ø30mm Atom Recessed Ø52mm 700mA Atom Recessed Ø52mm 350mA Atom Recessed Ø52mm 500mA Atom Recessed Ø52mm Zoom



Drivers
Drivers

P. 984



ON-OFF
IP20

71-B681-00-00

71-B332-00-00

71-6652-00-00

71-7551-00-00

71-6652-00-00



PHASE CUT 240V
IP20

71-4898-00-00 ✂
Min. 1 - Max.5

71-7663-00-00

71-A297-00-00

71-A298-00-00

71-A297-00-00



DALI2
IP20

71-B407-00-00
Min. 2 - Max.4

71-A190-00-00

71-A191-00-00

71-A192-00-00

71-A191-00-00

Lens accessories

Accessoires optiques



Elliptical diffuser (5u.)
Diffuseur elliptique
(5 u.)

71-6274-00-00

71-6280-00-00

71-6280-00-00

71-6280-00-00

-



Halo fader (5u.)
Diffuseur de halo (5 u.)

71-6275-00-00

71-6281-00-00

71-6281-00-00

71-6281-00-00

-



Visual comfort (1u.)
Confort visuel (1 u.)

14 ○

71-6276-14-00

71-6282-14-00

71-6282-14-00

71-6282-14-00

-

60 ●

71-6276-60-00

71-6282-60-00

71-6282-60-00

71-6282-60-00

-



Honeycomb panel (5u.)
Grille en nid d'abeille
(5 u.)

60 ●

71-6273-60-00

71-6279-60-00

71-6279-60-00

71-6279-60-00

-



Visor
Visière

60 ●

71-6277-60-00

71-6283-60-00

71-6283-60-00

71-6283-60-00

-



Front ring
Anneau frontal

14 ○

71-6436-14-00

71-6437-14-00

71-6437-14-00

71-6437-14-00

-

23 ●

71-6436-23-00

71-6437-23-00

71-6437-23-00

71-6437-23-00

-

Connective controllers
Contrôleurs connectés

P. 969



Consult the available control systems / Consultez les systèmes de contrôle disponibles:

DALI2 / DALI2

Bluetooth wireless / Sans fil Bluetooth

Autonomous / Autonome

Bento

Designed by LedsC4 Architectural

Downlights
P. 232

Low Voltage
P. 126

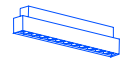

INDOOR



This option is designed for ceilings where recessing is difficult. It has the same characteristics as the Bento collection in a surface format. With the option of 3, 6 or 12 lenses, it offers completely homogeneous lighting in a range of angles of aperture that vary from Spot (15°) to Flood (50°).

Cette variante est pensée pour les plafonds qui présentent des difficultés d'encastrement. Elle présente les mêmes caractéristiques que la collection Bento, mais au format surface. Avec l'option 3, 6 et 12 lentilles, ce modèle offre une lumière totalement homogène et une plage d'ouverture de l'angle lumineux qui va de Spot (15°) à Flood (50°).

Bento Surface 3 LEDs Not Driver

BODY MAT	50000h
AL	L80 B20

3	IP
MacAdam	23

UGR	
<13	

WELL	
------	--



14 60



Remote driver

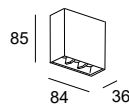

LED						max.700mA 9V	
K	CRI	W	Real Lm	Optics	Code		
2700	90	6.1	560	17°	15-7098	60	60
2700	90	6.1	638	38°	15-7099	14	60
2700	90	6.1	603	47°	15-7100		
3000	90	6.1	560	17°	15-7101	60	60
3000	90	6.1	638	38°	15-7161	14	60
3000	90	6.1	603	47°	15-7169		
4000	90	6.1	609	17°	15-7184	60	60
4000	90	6.1	693	38°	15-7185	14	60
4000	90	6.1	655	47°	15-7186		

Drivers

Drivers

P. 984



ON-OFF
IP20

71-B232-00-00



PHASE CUT 240V
IP20

71-7663-00-00



1-10V
DALI2 / PUSH
IP20

71-4706-00-00

Min. 1 - Max.8

71-A190-00-00

PROJECTEURS / PLAFONNIERS
SPOTLIGHTS / CEILING

Bento Surface 3 LEDs

BODY MAT	50000h	3	IP	UGR		LOW		
AL	L80 B20	MacAdam	23	<13		FLICKER		

○ ●
14 60

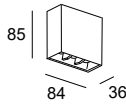

LED									
K	CRI	W Total	Real Lm	Optics	Code				
2700	90	8	560	18°	15-7098				
2700	90	8	638	38°	15-7099	14	- OS	ON-OFF 220-240V	
2700	90	8	603	47°	15-7100	60			
3000	90	8	560	18°	15-7101				
3000	90	8	638	38°	15-7161	14	- OS	ON-OFF 220-240V	
3000	90	8	603	47°	15-7169	60			
4000	90	8	609	18°	15-7184				
4000	90	8	693	38°	15-7185	14	- OS	ON-OFF 220-240V	
4000	90	8	655	47°	15-7186	60			

Bento Surface 6 LEDs

BODY MAT	50000h	3	IP	UGR			
AL	L80 B20	MacAdam	23	<13			

○ ●
14 60

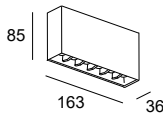

LED									
K	CRI	W Total	Real Lm	Optics	Code				
2700	90	14.7	1119	17°	15-7187				
2700	90	14.7	1276	38°	15-7188	14	- MS	PHASE CUT 220-240V	
2700	90	14.7	1205	47°	15-7189	60	- DS	DALI-2 220-240V	
3000	90	14.7	1119	17°	15-7190				
3000	90	14.7	1276	38°	15-7191	14	- MS	PHASE CUT 220-240V	
3000	90	14.7	1205	47°	15-7192	60	- DS	DALI-2 220-240V	
4000	90	14.7	1216	17°	15-7193				
4000	90	14.7	1387	38°	15-7194	14	- MS	PHASE CUT 220-240V	
4000	90	14.7	1310	47°	15-7195	60	- DS	DALI-2 220-240V	

Bento Surface 12 LEDs

BODY MAT	50000h	3	IP	UGR	
AL	L80 B20	MacAdam	23	<13	

○ ●
14 60

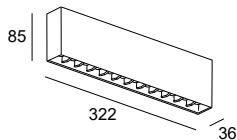

LED									
K	CRI	W Total	Real Lm	Optics	Code				
2700	90	25.7	2240	17°	15-7196				
2700	90	25.7	2552	38°	15-7197	14	- MS	PHASE CUT 220-240V	
2700	90	25.7	2412	47°	15-7198	60	- DS	DALI-2 220-240V	
3000	90	25.7	2240	17°	15-7199				
3000	90	25.7	2552	38°	15-7200	14	- MS	PHASE CUT 220-240V	
3000	90	25.7	2412	47°	15-7201	60	- DS	DALI-2 220-240V	
4000	90	25.7	2435	17°	15-7202				
4000	90	25.7	2774	38°	15-7203	14	- MS	PHASE CUT 220-240V	
4000	90	25.7	2622	47°	15-7204	60	- DS	DALI-2 220-240V	

Bento IP66

Designed by LedsC4 Architectural



Full IP66 protection, which means the luminaire can be installed in damp spaces or those that are exposed to dust and water.

Protection IP66 complète qui permet d'installer le luminaire dans des espaces humides ou exposés à la poussière et à l'eau.

Bento Surface 6 LEDS IP66

IP 66	IK 9	DIF MAT GLA	UGR <13			
----------	---------	----------------	------------	--	--	--

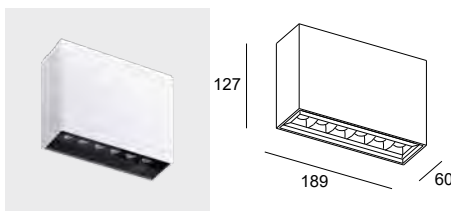

LED								
K	CRI	W Total	Real Lm	Optics	Code			
						14		
						60		
2700	90	14.7	1119	18°	15-A116	34	OU	ON-OFF 100-277V
2700	90	14.7	1276	38°	15-A117	J6	DS	DALI-2/PUSH 220-240V
2700	90	14.7	1205	47°	15-A118	E3		
						DL		
						Z5		
						14		
						60		
3000	90	14.7	1119	18°	15-A119	34	OU	ON-OFF 100-277V
3000	90	14.7	1276	38°	15-A120	J6	DS	DALI-2/PUSH 220-240V
3000	90	14.7	1205	47°	15-A121	E3		
						DL		
						Z5		
						14		
						60		
4000	90	14.7	1216	18°	15-A122	34	OU	ON-OFF 100-277V
4000	90	14.7	1387	38°	15-A123	J6	DS	DALI-2/PUSH 220-240V
4000	90	14.7	1310	47°	15-A124	E3		
						DL		
						Z5		

Kiva

Designed by LedsC4 Architectural



+ Kiva

Low Voltage
P. 118

Recessed
P. 314

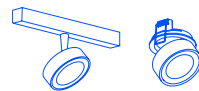

Functionality and aesthetics in the same solution

Fonctionnalité et esthétique dans une même solution

The Kiva collection has been expanded with new features designed to light any space with ease thanks to a 350° rotation. With recessed, surface-mounted, track or low-voltage versions, the extended collection offers superior versatility and functionality.

La collection Kiva s'étoffe avec de nouvelles fonctionnalités, conçues pour éclairer n'importe quel espace en toute facilité grâce à sa rotation à 180°. Offrant la possibilité d'une installation encastrée, de surface, sur rail ou en versions basse tension, la collection gagne en polyvalence et en fonctionnalité.



Kiva Surface Ø75mm

BODY MAT
AL



50000h
L80 B20

2
MacAdam

IP
20

LOW
FLICKER

90°

360°



14 60 81 DN

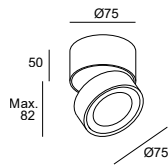

LED										
K	CRI	W Total	Real Lm	Optics	Code					
2700	90	7.8	458	19°	15-8035	14	60	81	DN	MS PHASE CUT 220-240V
3000	90	7.8	530	19°	15-8036	14	60	81	DN	MS PHASE CUT 220-240V

Kiva Surface Ø95mm

BODY MAT
AL



50000h
L80 B20

2
MacAdam

IP
20

360°

90°



14 60 81 DN

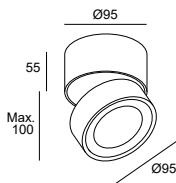

LED										
K	CRI	W Total	Real Lm	Optics	Code					
2700	90	13.2	1172	23°	15-8037	14	60	81	DN	MS DS PHASE CUT 220-240V DALI-2 120-240V
3000	90	13.2	1320	23°	15-8038	14	60	81	DN	MS DS PHASE CUT 220-240V DALI-2 120-240V

Kiva Recessed



Featuring a delicate and simple design, Kiva is an ideal solution for precise lighting in spaces requiring design and technicality in equal measure. Its rotation capacity, both longitudinal and revolving, allows the light beam to be easily focused to where the project requires it.

Arborant une esthétique simple et délicate, Kiva est une solution idéale pour éclairer avec précision les espaces qui nécessitent design et technicité à parts égales. Sa capacité de rotation, à la fois longitudinale et pivotante, permet de focaliser facilement le faisceau lumineux là où le projet l'exige.

Longitudinal and swivel rotation Rotation longitudinale et pivotante



14

60

81

DN



Kiva Recessed Ø75mm

BODY MAT		IP	UGR	2					
AL		23	<16	MacAdam		90°	360°		

14 60 81 DN

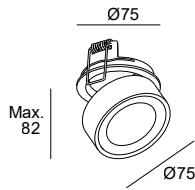

68 0-20 mm

LED						
K	CRI	W Total	Real Lm	Optics	Code	
2700	90	8.8	458	19°	90-8035	14 OU ON-OFF 100-240V
						60 DS DALI-2/PUSH 100-240V
						81 XB CASAMBI 220-240V
						DN
3000	90	8.8	530	19°	90-8036	14 OU ON-OFF 100-240V
						60 DS DALI-2/PUSH 100-240V
						81 XB CASAMBI 220-240V
						DN

Kiva Recessed Ø95mm

BODY MAT		IP	UGR	2					
AL		23	<16	MacAdam		90°	360°		

14 60 81 DN

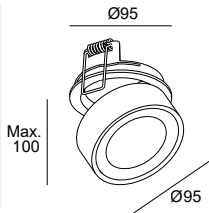

88 0-20 mm

LED						
K	CRI	W Total	Real Lm	Optics	Code	
2700	90	14	1172	23°	90-8037	14 OU ON-OFF 100-240V
						60 DS DALI-2 100-240V
						81 XB CASAMBI 220-240V
						DN
3000	90	14	1320	23°	90-8038	14 OU ON-OFF 100-240V
						60 DS DALI-2 100-240V
						81 XB CASAMBI 220-240V
						DN

Lineal Light Systems

Systemes d'éclairage linéaires

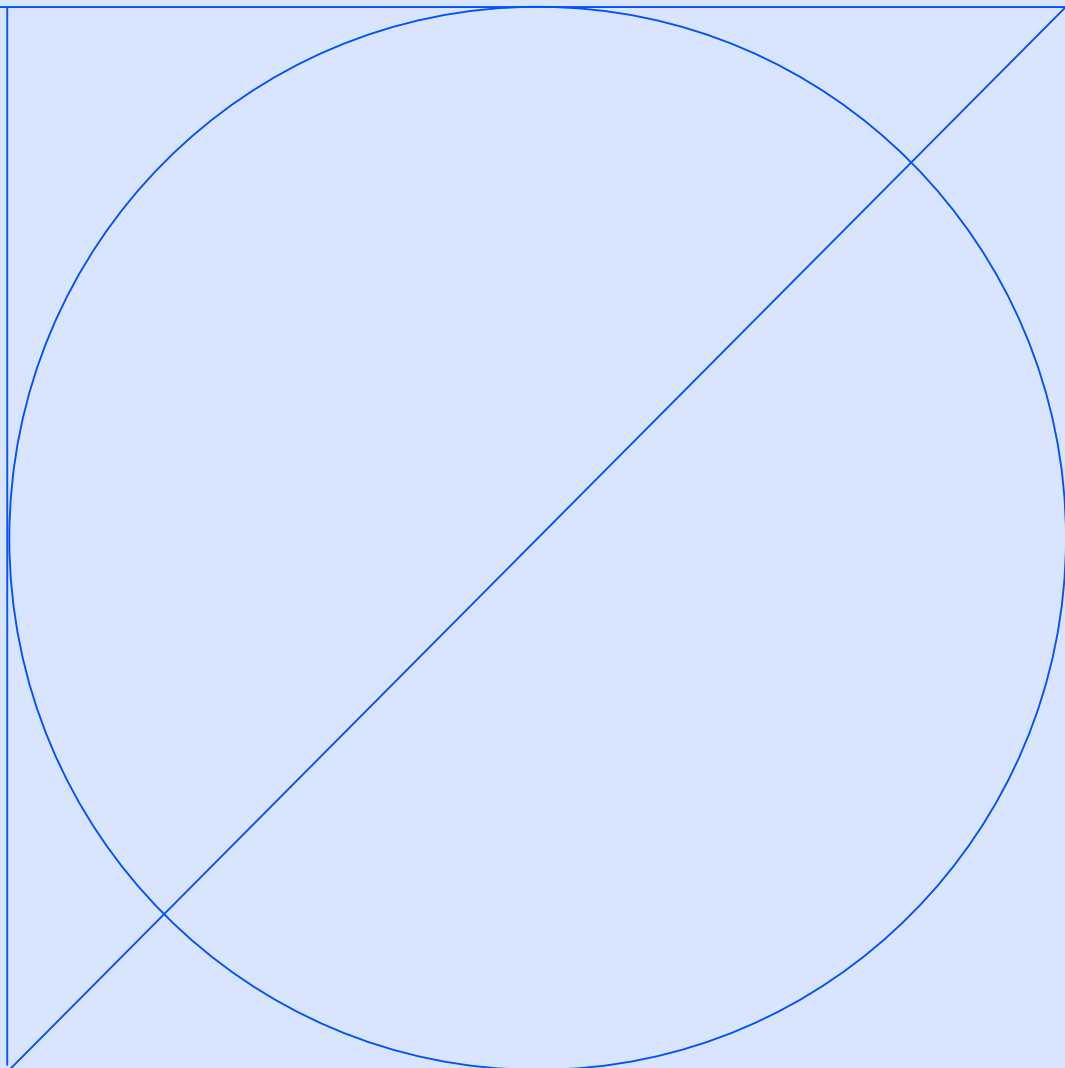
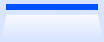

Apex

318



Infinite Pro

338

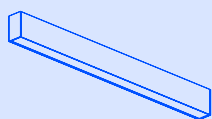

Infinite Slim

366

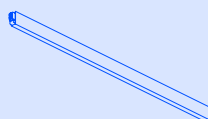

Lineal

376

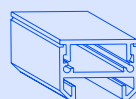

Taglio di Luce

378

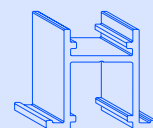



+ Apex

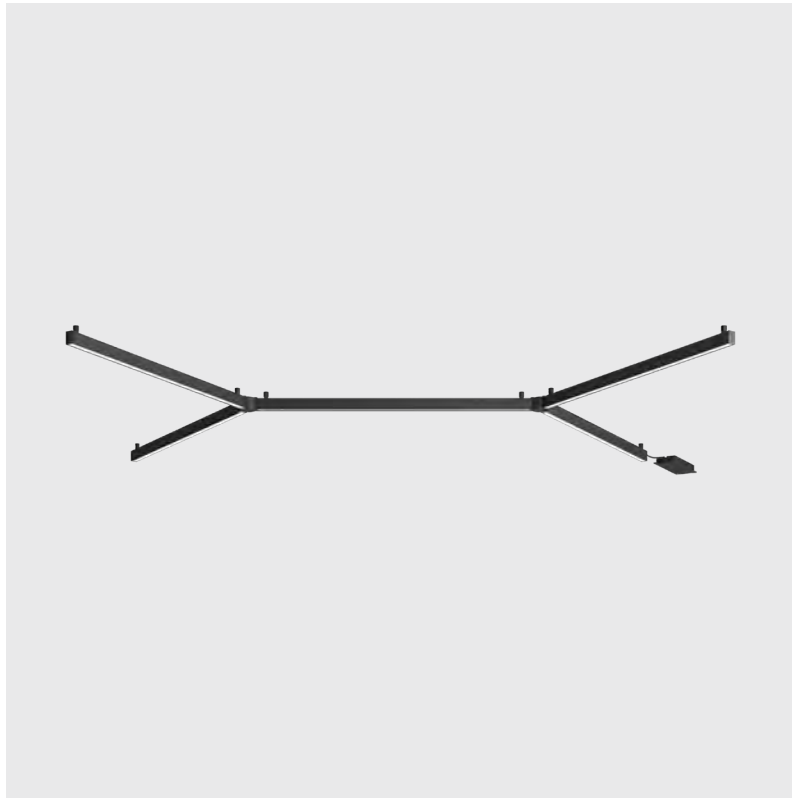

Apex challenges the dimensionality of the space with its geometries Apex défie la dimensionnalité de l'espace avec ses géométries

Spaces communicate through the composition of their elements. Apex is a flexible solution, with a living structure that adapts without limits to the imagination of architects and designers. Its constructions can be simple, with a single light source, or complex, forming different geometric shapes thanks to its system's interlinking possibilities.

Les espaces communiquent à travers la composition de leurs éléments. Apex est une solution flexible dotée d'une structure vivante qui s'adapte sans limites à l'imagination des architectes et designers. Ses constructions peuvent être simples, avec une seule source lumineuse, ou complexes, pour former différentes figures géométriques grâce à l'enchaînement de son système.

Versatility to create highly diverse compositions
Possibilité de compositions très variées

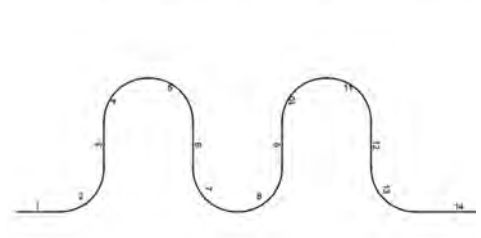
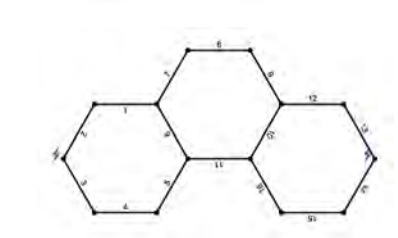
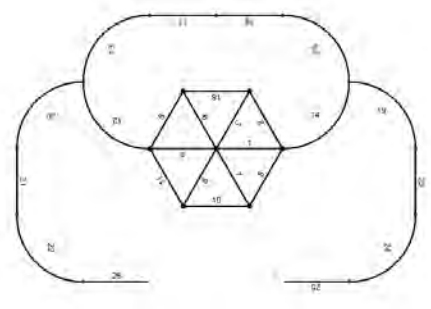
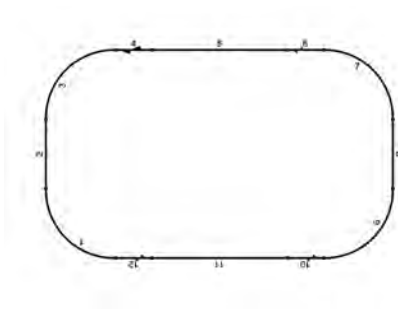





Different profiles and construction elements to create different compositions in pendant or surface installations
 Différents profilés et éléments constructifs pour créer des compositions variées dans des installations suspendues ou de surface

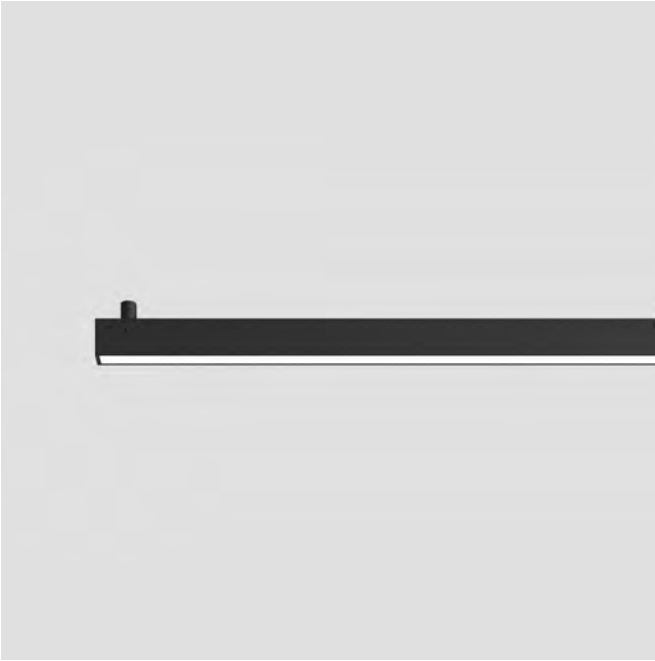

Linear profile.
 Profilé linéaire.



Arch-shaped profile.
 Profilé en arc.

Nodes with up to 6 outputs
 Nœud comprenant jusqu'à 6 sorties



Node 4.
 Nœud 4.

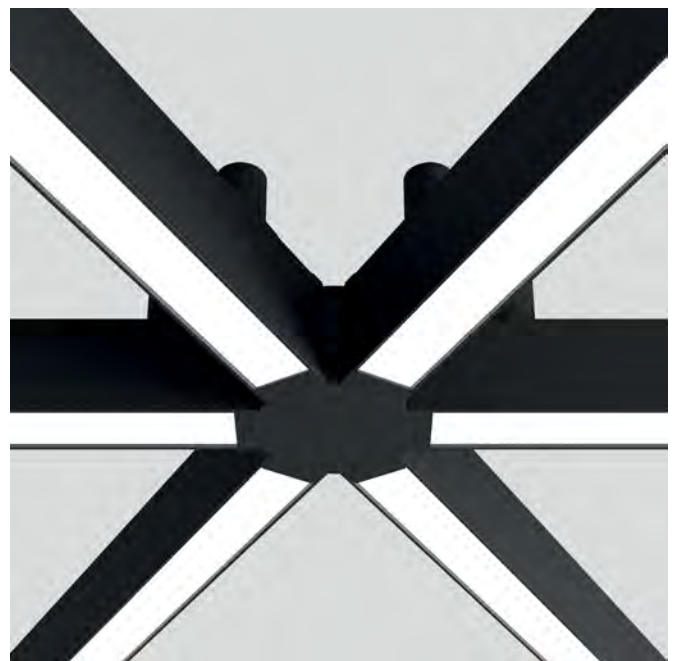

Node 6.
 Nœud 6.

Installation and versatility

Installation et polyvalence

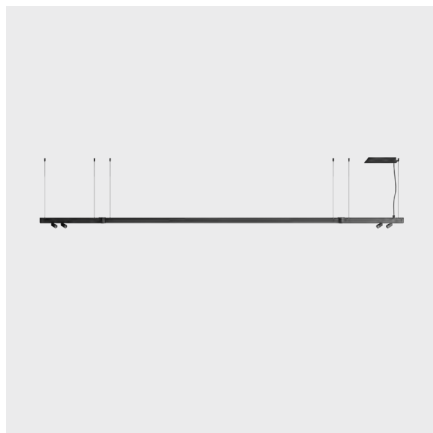
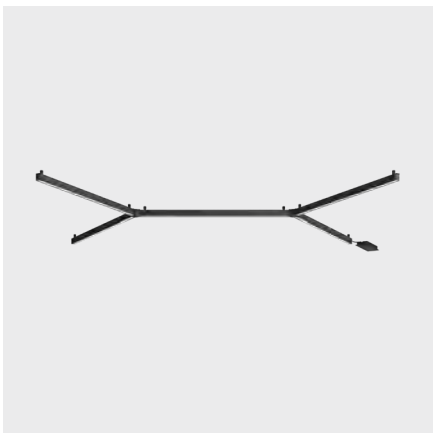
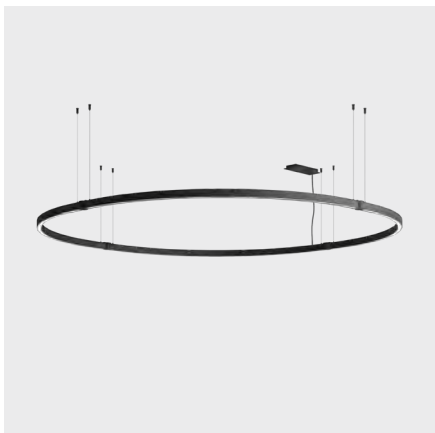
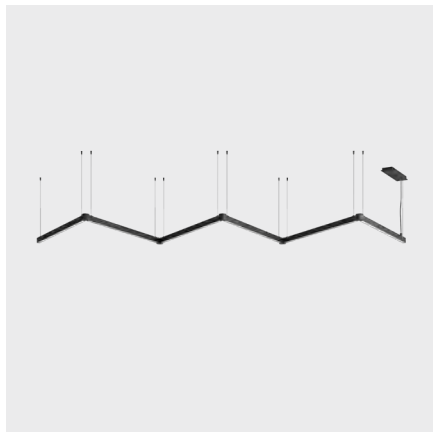
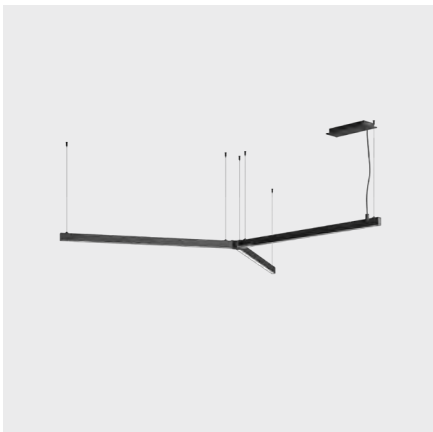
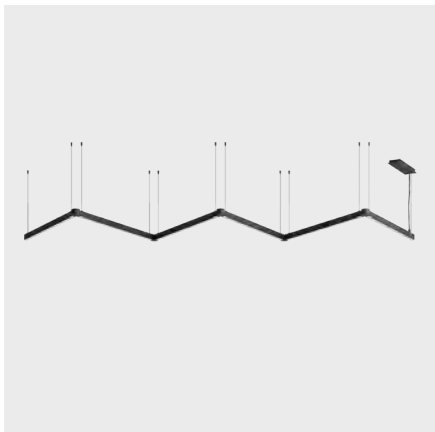
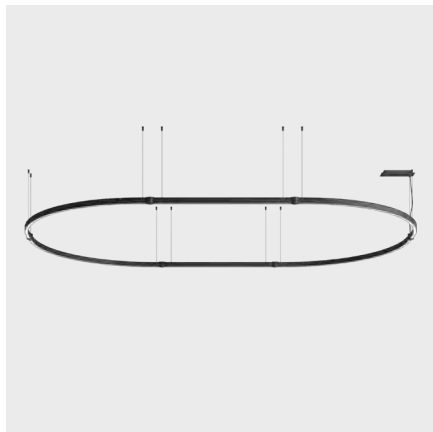
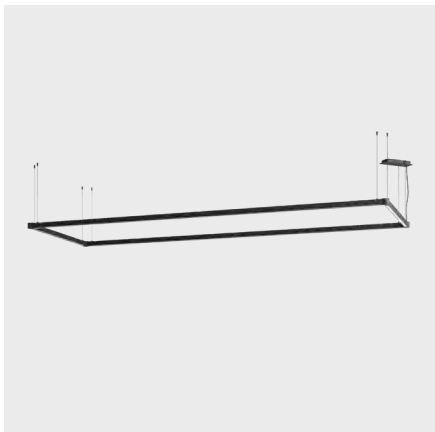



Type of lighting with Apex according to need

Type d'éclairage avec Apex selon les besoins

Opal



Diffuse lighting
Éclairage diffus

Bento UGR < 10



52° controlled angle
Angle contrôlé de 52°



Spot 30 mm



Spot 52 mm

Type of rosette

Type de rosette

Surface
Surface

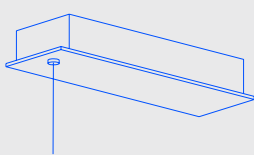

Recessed
Encastré

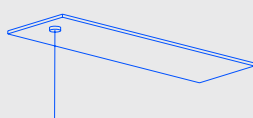

Remote equipment*

Équipement à distance*



*Rear access is required for this installation

*Un accès arrière est nécessaire pour cette installation

W	Metres — per 1.5 mm ² cable section	Metres — per 2.5 mm ² cable section
	Mètres - par section de câble 1,5 mm ²	Mètres - par section de câble 2,5 mm ²
75	18	30
120	14	20
180	8	15
240	5	13

*Maximum distance between the mini flush-mounted rosette and the equipment depending on the cable cross-section.

*Distance maximale entre la mini rosette encastrée et l'équipement en fonction de la section du câble.



Apex H (AW35) in offices Fuego Camina Conmigo. Barcelona. Photography: Enric Badrinas.
Apex H (AW35) dans les bureaux Fuego Camina Conmigo. Barcelone. Photographie : Enric Badrinas.

Built-in Smart Casambi Bluetooth Smart Casambi Bluetooth intégré

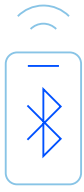

The options with built-in Casambi Bluetooth enable quick and easy access to smart functionalities.

Les options avec Casambi Bluetooth intégré permettent d'accéder à des fonctionnalités intelligentes en toute facilité et rapidité.

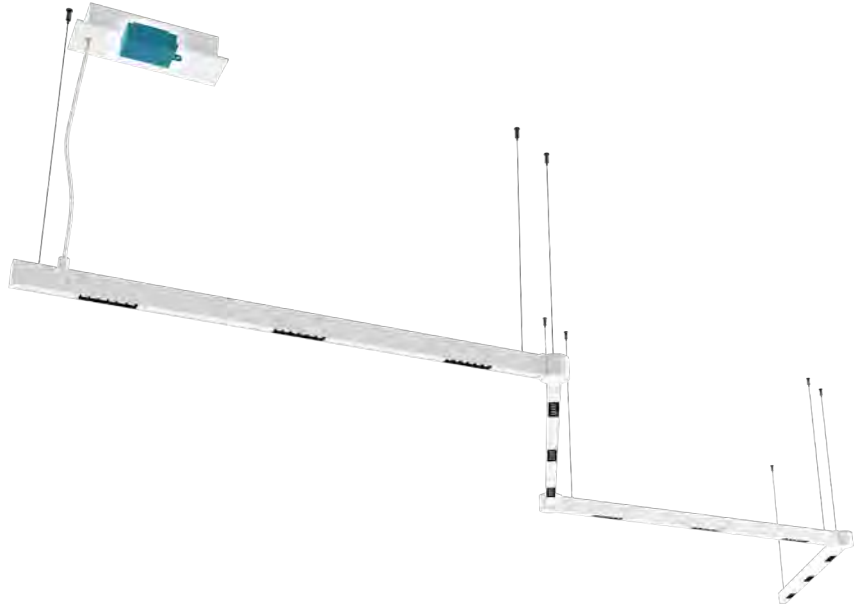

The regulation of the light level according to the use of the space
(human presence) translates into great energy savings

La régulation du niveau d'éclairage en fonction de l'utilisation de l'espace
(présence humaine) se traduit par de grandes économies d'énergie



Apex comes with the ENEC certification, attesting to the product's quality
and safety in compliance with European standards.

Le modèle Apex bénéficie du label ENEC qui démontre la qualité et la sécurité
du produit conformément aux normes européennes.



Apex configurator

Configurateur Apex



apex.leds-c4.com

INDOOR

Infinite configuration options in a quick and easy way thanks to our online configurator.

Une infinité d'options de configuration de manière simple et rapide grâce à notre configurateur en ligne.

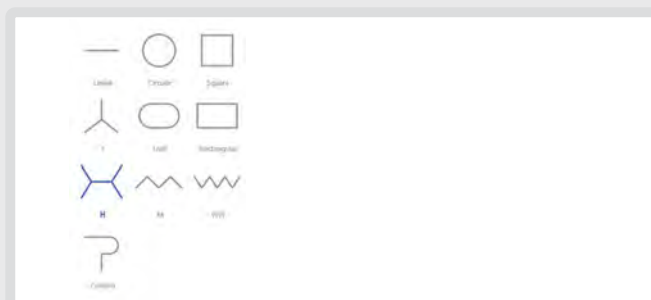
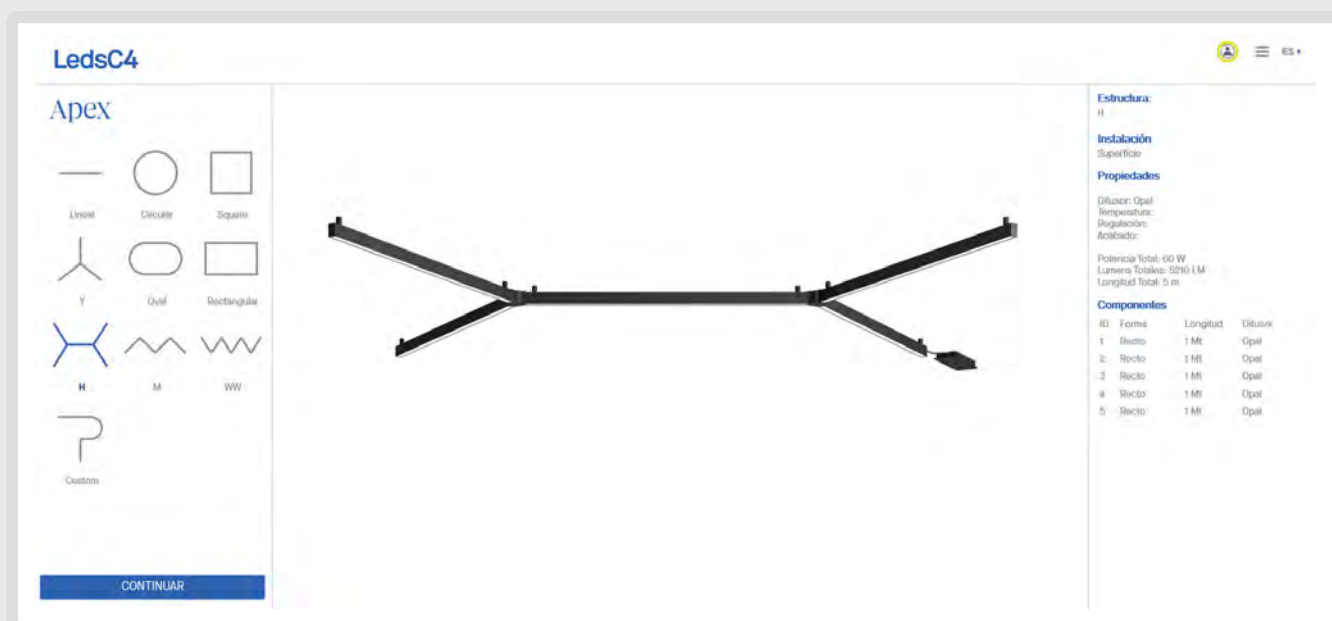

1 Shape selection

Sélection de la forme

Choice of Standard or Custom configuration.
Choisissez parmi une configuration standard ou personnalisée.

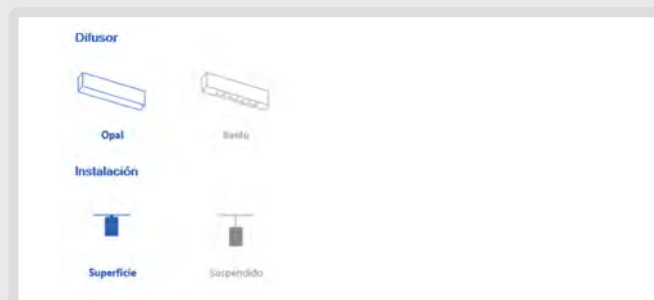

2 Choice of size, diffuser and installation

Choix de la configuration standard ou personnalisée

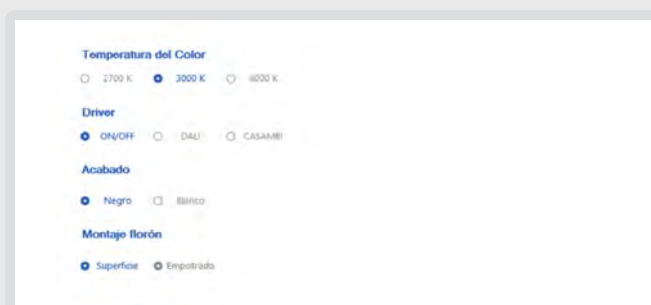

3 Choice of colour temperature, setting and finish

Choix de la taille, du diffuseur et de l'installation

4 Download documentation

Télécharger la documentation

LINEAL LIGHT SYSTEMS | SYSTÈMES D'ÉCLAIRAGE LINÉAIRES

Apex Lineal Simple

IP
20

BODY MAT
AL



50000h
L80 B20

2;3
MacAdam

UGR
BENTO <10



Code example / Exemple d'élaboration d'une référence: **AW14-12VAPLOS14**

Model	Optics	W	K	CRI	Real Lm	Source	Finishes	
AW14 - Lineal / Pendant 	12VAPL	Opal	12	2700	90	1042	OS ON-OFF 220-240V	14 60
	12WAPL	Opal	12	3000	90	1042	OR ON-OFF Remot 220-240V	
	12XAPL	Opal	12	4000	90	1042	DS DALI 220-240V	
	18V9BE	Bento	20.1	2700	90	1563	DR DALI Remot 220-240V	
	18W9BE	Bento	20.1	3000	90	1563	XB CASAMBI 220-240V	
	18X9BE	Bento	20.1	4000	90	1563	XR CASAMBI Remot 220-240V	
AW15 - Lineal / Pendant 	24VAPL	Opal	24	2700	90	2048	OS ON-OFF 220-240V	14 60
	24WAPL	Opal	24	3000	90	2048	OR ON-OFF Remot 220-240V	
	24XAPL	Opal	24	4000	90	2048	DS DALI 220-240V	
	36V9BE	Bento	38.4	2700	90	3126	DR DALI Remot 220-240V	
	36W9BE	Bento	38.4	3000	90	3126	XB CASAMBI 220-240V	
	36X9BE	Bento	38.4	4000	90	3126	XR CASAMBI Remot 220-240V	
AW16 - Lineal / Pendant 	36VAPL	Opal	36	2700	90	3126	OS ON-OFF 220-240V	14 60
	36WAPL	Opal	36	3000	90	3126	OR ON-OFF Remot 220-240V	
	36XAPL	Opal	36	4000	90	3126	DS DALI 220-240V	
	54V9BE	Bento	58.6	2700	90	4689	DR DALI Remot 220-240V	
	54W9BE	Bento	58.6	3000	90	4689	XB CASAMBI 220-240V	
	54X9BE	Bento	58.6	4000	90	4689	XR CASAMBI Remot 220-240V	

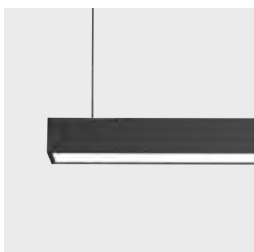
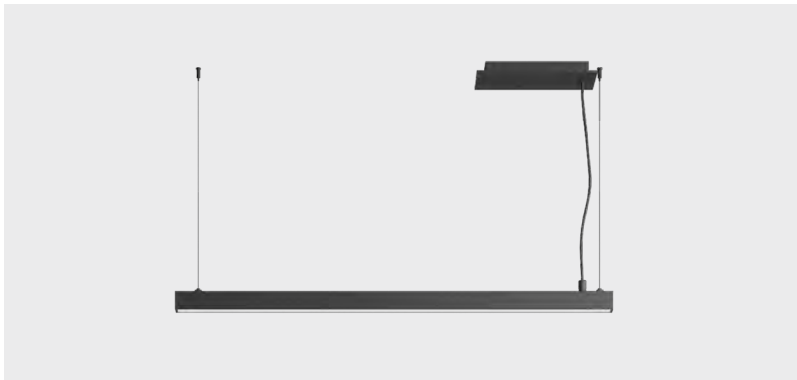

Opal

Bento (UGR<10)

Apex Lineal Double Spot Small

IP
20

BODY MAT
AL



50000h
L80 B20

2:3
MacAdam

UGR
BENTO <10

90°

320°



Code exemple / Exemple d'élaboration d'une référence: **AW45-18VAPLOS14**

Model	Optics	W	K	CRI	Real Lm	Source	Finishes	
AW45 - Lineal / Pendant 1595 mm / 2 Spots	18VAPL	Opal	18	2700	90	1770	OS ON-OFF 220-240V	14 60
	18WAPL	Opal	18	3000	90	1770	OR ON-OFF Remot 220-240V	
	18XAPL	Opal	18	4000	90	1770	DS DALI 220-240V	
	24V9BE	Bento	27.3	2700	90	2291	DR DALI Remot 220-240V	
	24W9BE	Bento	27.3	3000	90	2291	XB CASAMBI 220-240V	
	24X9BE	Bento	27.3	4000	90	2291	XR CASAMBI Remot 220-240V	
AW46 - Lineal / Pendant 3180 mm / 4 Spots	36VAPL	Opal	36	2700	90	3540	OS ON-OFF 220-240V	14 60
	36WAPL	Opal	36	3000	90	3540	OR ON-OFF Remot 220-240V	
	36XAPL	Opal	36	4000	90	3540	DS DALI 220-240V	
	48V9BE	Bento	52.8	2700	90	4582	DR DALI Remot 220-240V	
	48W9BE	Bento	52.8	3000	90	5074	XB CASAMBI 220-240V	
	48X9BE	Bento	52.8	4000	90	4582	XR CASAMBI Remot 220-240V	
AW47 - Lineal / Pendant 4190 mm / 4 Spots	48VAPL	Opal	48	2700	90	1770	OS ON-OFF 220-240V	14 60
	48WAPL	Opal	48	3000	90	1770	OR ON-OFF Remot 220-240V	
	48XAPL	Opal	48	4000	90	1770	DS DALI 220-240V	
	66V9BE	Bento	73	2700	90	2291	DR DALI Remot 220-240V	
	66W9BE	Bento	73	3000	90	2291	XB CASAMBI 220-240V	
	66X9BE	Bento	73	4000	90	2291	XR CASAMBI Remot 220-240V	

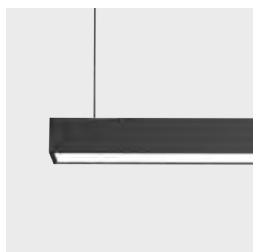

Opal



Bento (UGR<10)

**Apex Lineal
Double Spot Big**

IP
20

BODY MAT
AL



50000h
L80 B20

2:3
MacAdam

UGR
BENTO <10

90°

120°



Code example / Exemple d'élaboration d'une référence: **AW58-36VAPLOS14**

Model	Optics	W	K	CRI	Real Lm	Source	Finishes	
AW58 - Lineal / Pendant 	36VAPL	Opal	36	2700	90	2898	OS ON-OFF 220-240V	14
	36WAPL	Opal	36	3000	90	2898	OR ON-OFF Remot 220-240V	60
	36XAPL	Opal	36	4000	90	2898	DS DALI 220-240V	
	42V9BE	Bento	46.1	2700	90	3419	DR DALI Remot 220-240V	
	42W9BE	Bento	46.1	3000	90	3665	XB CASAMBI 220-240V	
	42X9BE	Bento	46.1	4000	90	3419	XR CASAMBI Remot 220-240V	
AW59 - Lineal / Pendant 	72VAPL	Opal	72	2700	90	3940	OS ON-OFF 220-240V	14
	72WAPL	Opal	72	3000	90	3940	OR ON-OFF Remot 220-240V	60
	72XAPL	Opal	72	4000	90	3940	DS DALI 220-240V	
	84V9BE	Bento	90.4	2700	90	6838	DR DALI Remot 220-240V	
	84W9BE	Bento	90.4	3000	90	7330	XB CASAMBI 220-240V	
	84X9BE	Bento	90.4	4000	90	6838	XR CASAMBI Remot 220-240V	
AW61 - Lineal / Pendant 	84VAPL	Opal	84	2700	90	6838	OS ON-OFF 220-240V	14
	84WAPL	Opal	84	3000	90	6838	OR ON-OFF Remot 220-240V	60
	84XAPL	Opal	84	4000	90	6838	DS DALI 220-240V	
	CPV9BE	Bento	110.6	2700	90	8401	DR DALI Remot 220-240V	
	CPW9BE	Bento	110.6	3000	90	8401	XB CASAMBI 220-240V	
	CPX9BE	Bento	110.6	4000	90	8401	XR CASAMBI Remot 220-240V	

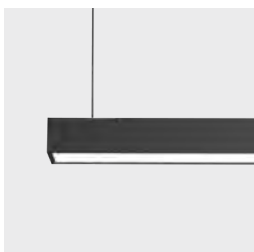

Opal

Bento (UGR<10)

Apex Lineal Triple Spot Small

IP
20

BODY MAT
AL



50000h
L80 B20

2:3
MacAdam

UGR
BENTO <10

90°

320°



Code example / Exemple d'élaboration d'une référence: **AW52-21VAPLOS14**

Model	Optics	W	K	CRI	Real Lm	Source	Finishes	
AW52 - Lineal / Pendant 1595 mm / 3 Spots	21VAPL	Opal	21	2700	90	2134	OS ON-OFF 220-240V	14
	21WAPL	Opal	21	3000	90	2134	OR ON-OFF Remot 220-240V	60
	21XAPL	Opal	21	4000	90	2134	DS DALI 220-240V	
	27V9BE	Bento	30.3	2700	90	2655	DR DALI Remot 220-240V	
	27W9BE	Bento	30.3	3000	90	2901	XB CASAMBI 220-240V	⚡
	27X9BE	Bento	30.3	4000	90	2655	XR CASAMBI Remot 220-240V	⚡
AW53 - Lineal / Pendant 3180 mm / 6 Spots	42VAPL	Opal	42	2700	90	4268	OS ON-OFF 220-240V	14
	42WAPL	Opal	42	3000	90	4268	OR ON-OFF Remot 220-240V	60
	42XAPL	Opal	42	4000	90	4268	DS DALI 220-240V	
	54V9BE	Bento	58.8	2700	90	5310	DR DALI Remot 220-240V	
	54W9BE	Bento	58.8	3000	90	5802	XB CASAMBI 220-240V	⚡
	54X9BE	Bento	58.8	4000	90	5310	XR CASAMBI Remot 220-240V	⚡
AW54 - Lineal / Pendant 4190 mm / 6 Spots	54VAPL	Opal	54	2700	90	5310	OS ON-OFF 220-240V	14
	54WAPL	Opal	54	3000	90	5310	OR ON-OFF Remot 220-240V	60
	54XAPL	Opal	54	4000	90	5310	DS DALI 220-240V	
	72V9BE	Bento	79	2700	90	6873	DR DALI Remot 220-240V	
	72W9BE	Bento	79	3000	90	7611	XB CASAMBI 220-240V	⚡
	72X9BE	Bento	79	4000	90	6873	XR CASAMBI Remot 220-240V	⚡

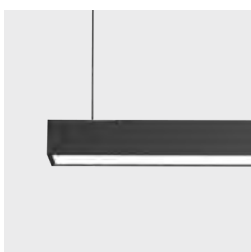

Opal



Bento (UGR<10)

Apex Square

IP
20

BODY MAT
AL



50000h
L80 B20

2;3
MacAdam

UGR
BENTO <10



Code example / Exemple d'élaboration d'une référence: **AW25-48VAPLOS14**

Model	Optics	W	K	CRI	Real Lm	Source	Finishes	
AW25 - Square / Pendant 	48VAPL	Opal	48	2700	90	4168	OS ON-OFF 220-240V	14
	48WAPL	Opal	48	3000	90	4168	OR ON-OFF Remot 220-240V	60
	48XAPL	Opal	48	4000	90	4168	DS DALI 220-240V	
	72V9BE	Bento	80.4	2700	90	6252	DR DALI Remot 220-240V	
	72W9BE	Bento	80.4	3000	90	7236	XB CASAMBI 220-240V	
	72X9BE	Bento	80.4	4000	90	6252	XR CASAMBI Remot 220-240V	
AW26 - Square / Pendant 	96VAPL	Opal	96	2700	90	8336	OS ON-OFF 220-240V	14
	96WAPL	Opal	96	3000	90	8336	OR ON-OFF Remot 220-240V	60
	96XAPL	Opal	96	4000	90	8336	DS DALI 220-240V	
	C4V9BE	Bento	153.6	2700	90	12504	DR DALI Remot 220-240V	
	C4W9BE	Bento	153.6	3000	90	14472	XB CASAMBI 220-240V	
	C4X9BE	Bento	153.6	4000	90	12504	XR CASAMBI Remot 220-240V	
AW27 - Square / Pendant 	C4VAPL	Opal	144	2700	90	12504	OS ON-OFF 220-240V	14
	C4WAPL	Opal	144	3000	90	12504	OR ON-OFF Remot 220-240V	60
	C4XAPL	Opal	144	4000	90	12504	DS DALI 220-240V	
	D1V9BE	Bento	234.3	2700	90	18756	DR DALI Remot 220-240V	
	D1W9BE	Bento	234.3	3000	90	21708	XB CASAMBI 220-240V	
	D1X9BE	Bento	234.3	4000	90	18756	XR CASAMBI Remot 220-240V	

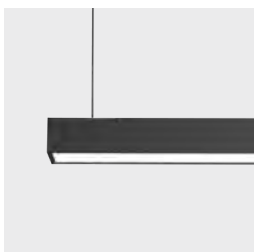

Opal



Bento (UGR<10)

Apex Rectangular

IP	BODY MAT		50000h	2;3	UGR		
20	AL		L80 B20	MacAdam	BENTO <10		

Code example / Exemple d'élaboration d'une référence: **AW29-72VAPLOS14**

INDOOR

Model	Optics	W	K	CRI	Real Lm	Source	Finishes	
AW29 - Rectangular / Pendant 	72VAPL	Opal	72	2700	90	6252	OS ON-OFF 220-240V	14
	72WAPL	Opal	72	3000	90	6252	OR ON-OFF Remot 220-240V	60
	72XAPL	Opal	72	4000	90	6252	DS DALI 220-240V	
	CPV9BE	Bento	117	2700	90	9378	DR DALI Remot 220-240V	
	CPW9BE	Bento	117	3000	90	10854	XB CASAMBI 220-240V	
	CPX9BE	Bento	117	4000	90	9378	XR CASAMBI Remot 220-240V	
AW32 - Rectangular / Pendant 	96VAPL	Opal	96	2700	90	8336	OS ON-OFF 220-240V	14
	96WAPL	Opal	96	3000	90	8336	OR ON-OFF Remot 220-240V	60
	96XAPL	Opal	96	4000	90	8336	DS DALI 220-240V	
	C4V9BE	Bento	157.3	2700	90	12504	DR DALI Remot 220-240V	
	C4W9BE	Bento	157.3	3000	90	14472	XB CASAMBI 220-240V	
	C4X9BE	Bento	157.3	4000	90	12504	XR CASAMBI Remot 220-240V	

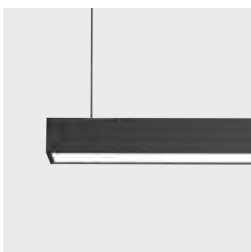
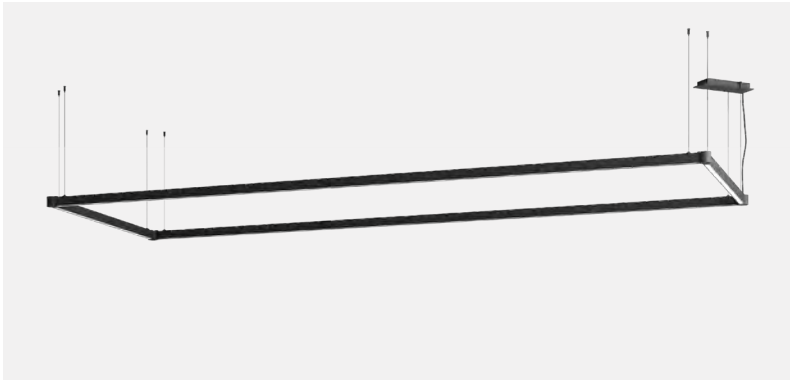

Opal



Bento (UGR<10)

LINEAL LIGHT SYSTEMS | SYSTÈMES D'ÉCLAIRAGE LINÉAIRES

Apex Circular

IP	BODY MAT		50000h	2:3		
40	AL		L80 B20	MacAdam		

Code example / Exemple d'élaboration d'une référence: **AW18-48VAPLOS14**

Model	Optics	W	K	CRI	Real Lm	Source	Finishes	
AW18 - Circular / Pendant 	48VAPL	Opal	60	2700	90	6545	OS ON-OFF 220-240V	14 60
	48WAPL	Opal	60	3000	90	6545	OR ON-OFF Remot 220-240V	
	48XAPL	Opal	60	4000	90	6545	DS DALI 220-240V	
	DR						DR DALI Remot 220-240V	
	XB						XB CASAMBI 220-240V	
	XR						XR CASAMBI Remot 220-240V	

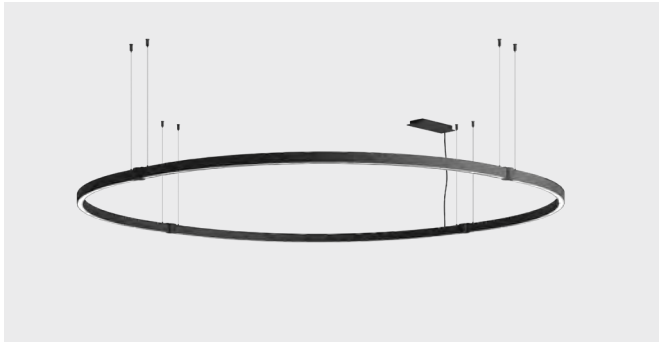

Apex Oval

IP	BODY MAT		50000h	2:3		
40	AL		L80 B20	MacAdam		

Code example / Exemple d'élaboration d'une référence: **AW21-48VAPLOS14**

Model	Optics	W	K	CRI	Real Lm	Source	Finishes	
AW21 - Oval / Pendant 	72VAPL	Opal	84	2700	90	6545	OS ON-OFF 220-240V	14 60
	72WAPL	Opal	84	3000	90	6545	OR ON-OFF Remot 220-240V	
	72XAPL	Opal	84	4000	90	6545	DS DALI 220-240V	
	DR						DR DALI Remot 220-240V	
	XB						XB CASAMBI 220-240V	
	XR						XR CASAMBI Remot 220-240V	

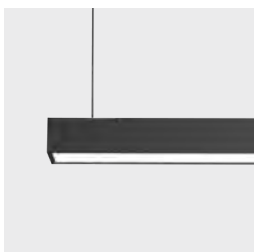
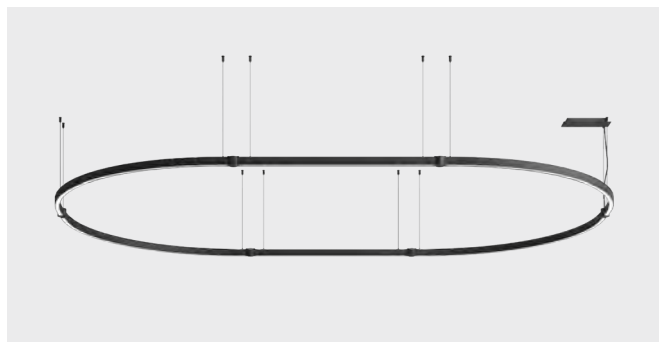

Opal

Apex H

IP	BODY MAT		50000h	2;3	UGR		
40	AL		L80 B20	MacAdam	BENTO <10		

Code exemple / Exemple d'élaboration d'une référence: **AW36-60VAPLOS14**

Model	Optics	W	K	CRI	Real Lm	Source	Finishes	
AW36 - "H" / Pendant 	60VAPL	Opal	60	2700	90	5210	OS ON-OFF 220-240V	14
	60WAPL	Opal	60	3000	90	5210	OR ON-OFF Remot 220-240V	
	60XAPL	Opal	60	4000	90	5210	DS DALI 220-240V	
	90V9BE	Bento	115.2	2700	90	9045	DR DALI Remot 220-240V	
	90W9BE	Bento	115.2	3000	90	9045	XB CASAMBI 220-240V	
	90X9BE	Bento	115.2	4000	90	9045	XR CASAMBI Remot 220-240V	

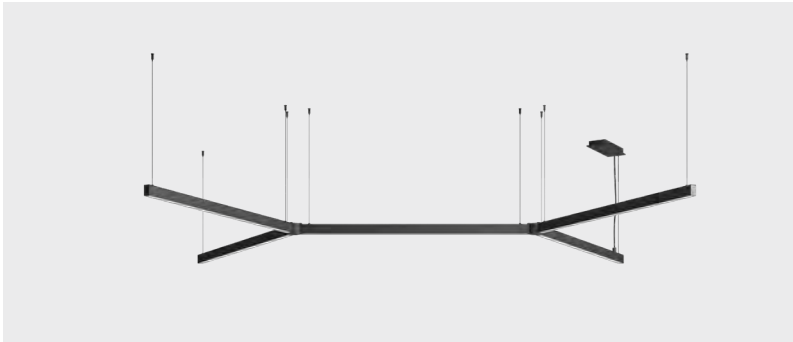

Apex Y

IP	BODY MAT		50000h	2;3	UGR		
40	AL		L80 B20	MacAdam	BENTO <10		

Code exemple / Exemple d'élaboration d'une référence: **AW34-60VAPLOS14**

Model	Optics	W	K	CRI	Real Lm	Source	Finishes	
AW34 - "Y" / Pendant 	36VAPL	Opal	36	2700	90	3126	OS ON-OFF 220-240V	14
	36WAPL	Opal	36	3000	90	3126	OR ON-OFF Remot 220-240V	
	36XAPL	Opal	36	4000	90	3126	DS DALI 220-240V	
	54V9BE	Bento	60.3	2700	90	4689	DR DALI Remot 220-240V	
	54W9BE	Bento	60.3	3000	90	5427	XB CASAMBI 220-240V	
	54X9BE	Bento	60.3	4000	90	4689	XR CASAMBI Remot 220-240V	

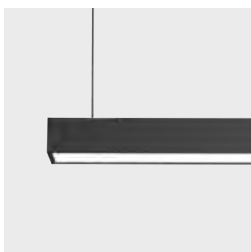
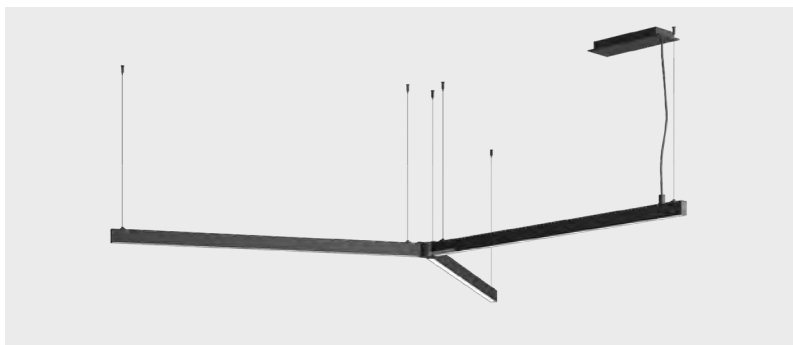

Opal

Bento (UGR<10)

Apex M

IP	BODY MAT		50000h	2;3		
40	AL		L80 B20	MacAdam		

Code example / Exemple d'élaboration d'une référence: **AW41-48VAPLOS14**

Model	Optics	W	K	CRI	Real Lm	Source	Finishes	
AW41 - "M" / Pendant 	48VAPL	Opal	48	2700	90	4168	OS ON-OFF 220-240V	14
	48WAPL	Opal	48	3000	90	4168	OR ON-OFF Remot 220-240V	60
	48XAPL	Opal	48	4000	90	4168	DS DALI 220-240V	
	72V9BE	Bento	80.4	2700	90	6252	DR DALI Remot 220-240V	
	72W9BE	Bento	80.4	3000	90	7236	XB CASAMBI 220-240V	
	72X9BE	Bento	80.4	4000	90	6252	XR CASAMBI Remot 220-240V	



Opal

Bento (UGR<10)

Apex W

IP	BODY MAT		50000h	2:3		
40	AL		L80 B20	MacAdam		

Code example / Exemple d'élaboration d'une référence: **AW38-72VAPLOS14**

INDOOR

Model	Optics	W	K	CRI	Real Lm	Source	Finishes	
AW38 - "W" / Pendant 	72VAPL	Opal	72	2700	90	6252	OS ON-OFF 220-240V	14
	72WAPL	Opal	72	3000	90	6252	OR ON-OFF Remot 220-240V	60
	72XAPL	Opal	72	4000	90	6252	DS DALI 220-240V	
	CPV9BE	Bento	120.6	2700	90	9378	DR DALI Remot 220-240V	
	CPW9BE	Bento	120.6	3000	90	10854	XB CASAMBI 220-240V	
	CPX9BE	Bento	120.6	4000	90	9378	XR CASAMBI Remot 220-240V	

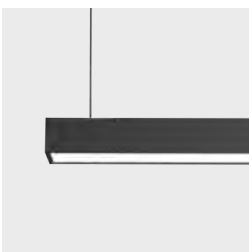
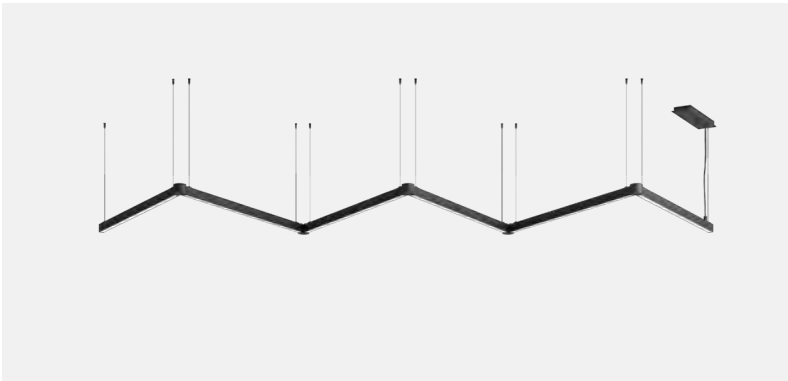

Opal



Bento (UGR<10)

LINEAL LIGHT SYSTEMS | SYSTÈMES D'ÉCLAIRAGE LINÉAIRES

Infinite Pro

Low Voltage
P. 132

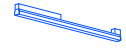

+ Infinite



A workplace solution that boosts employee well-being Solutions pour les espaces de travail respectueux du bien-être des personnes

Infinite Pro is the perfect solution to illuminate spaces requiring high levels of comfort, offering lighting designed to improve the well-being of both people and companies, especially in offices or workspaces where lighting quality is essential.

Infinite Pro est la solution parfaite pour éclairer des espaces qui exigent un haut niveau de confort, offrant un éclairage conçu pour améliorer le bien-être des personnes et des entreprises, en particulier dans les bureaux et espaces de travail où la qualité de la lumière est fondamentale.







Arts London project. The Smart Bluetooth Casambi functionality enables autonomous luminaire control.

Projet Arts London. Grâce à la fonctionnalité Smart Bluetooth Casambi, les luminaires peuvent être gérés de façon autonome.

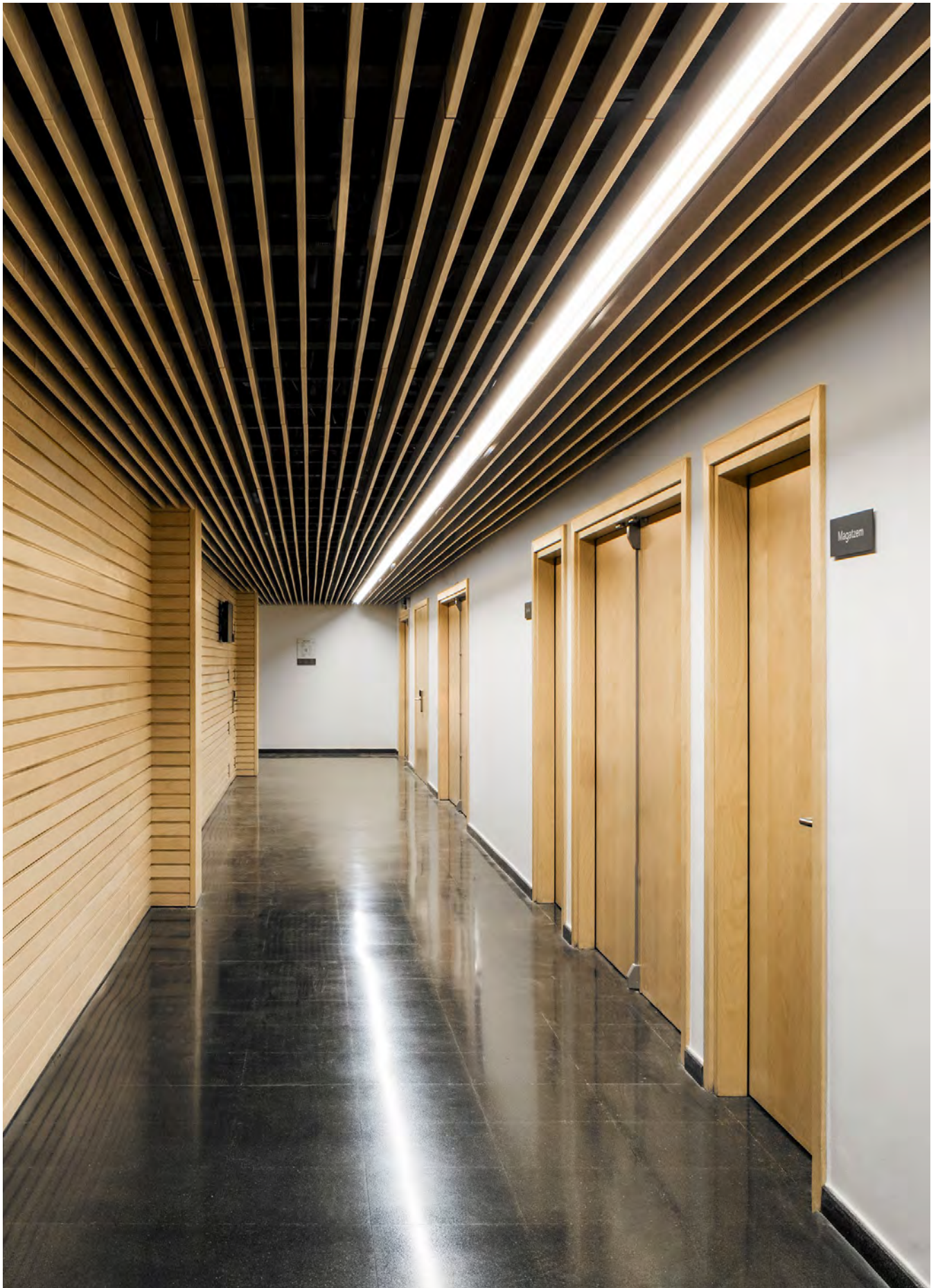

BCN Escola Industrial. Batwing lens with asymmetrical effect.
Escola Industrial BCN. Lentille à effet asymétrique Batwing.

Easy Click

Easy interlinking to create endless luminaires

Possibilité d'enchaînement facile pour créer des luminaires à l'infini





Special project with custom product for Manusa offices in Barcelona.
Projet spécial avec un produit personnalité pour les bureaux Manusa de Barcelone.

Different structure
and module
combinations
Différentes
combinaisons de
structure et de
module



Lentes
Lentilles

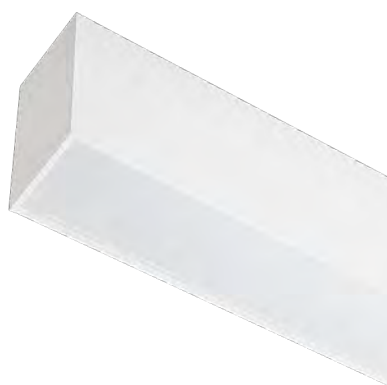

Opal
UGR < 22

Uniform and comfortable effect.
Effet homogène et confortable.



Microprisma
UGR < 22

Micro-etched solution that provides
added efficiency.
Solution micro-perforée pour une
efficacité accrue.



Haloprisma

UGR < 19

138 lm/W efficiency with a high luminaire output.

Efficacité de 138 lm/W avec un paquet de lumen élevé.



Hexacell

UGR < 10

High level of visual comfort with dark light effect.

Grand confort visuel grâce à l'effet lumière sombre.



Opticell

UGR < 16

Perfect balance between output angle (>74°), UGR <16 and an efficiency of 156 lm/W.

Équilibre parfait entre l'angle de sortie (>74°), l'UGR <16 et une efficacité de 156 lm/W.



90°

Optimal control, low glare and maximum precision.

Contrôle optimal, faible éblouissement et précision maximale.



Wall Washer

Highly uniform wall washer effect.

Effet wallwash de grande homogénéité.



Lente Eliptic

Designed for spaces that require a central distribution without lateral interference.

Conçu pour les espaces nécessitant une distribution centrale sans perturbations latérales.



Batwing

Suitable for linear layouts, as used in retail.

Idéal pour les distributions linéaires, telles que celles utilisées dans le commerce de détail.



Track

Integration of a three-phase rail for the installation of spotlights.

Intégration d'une piste triphasée pour l'installation de projecteurs.

Installation options

Options d'installation

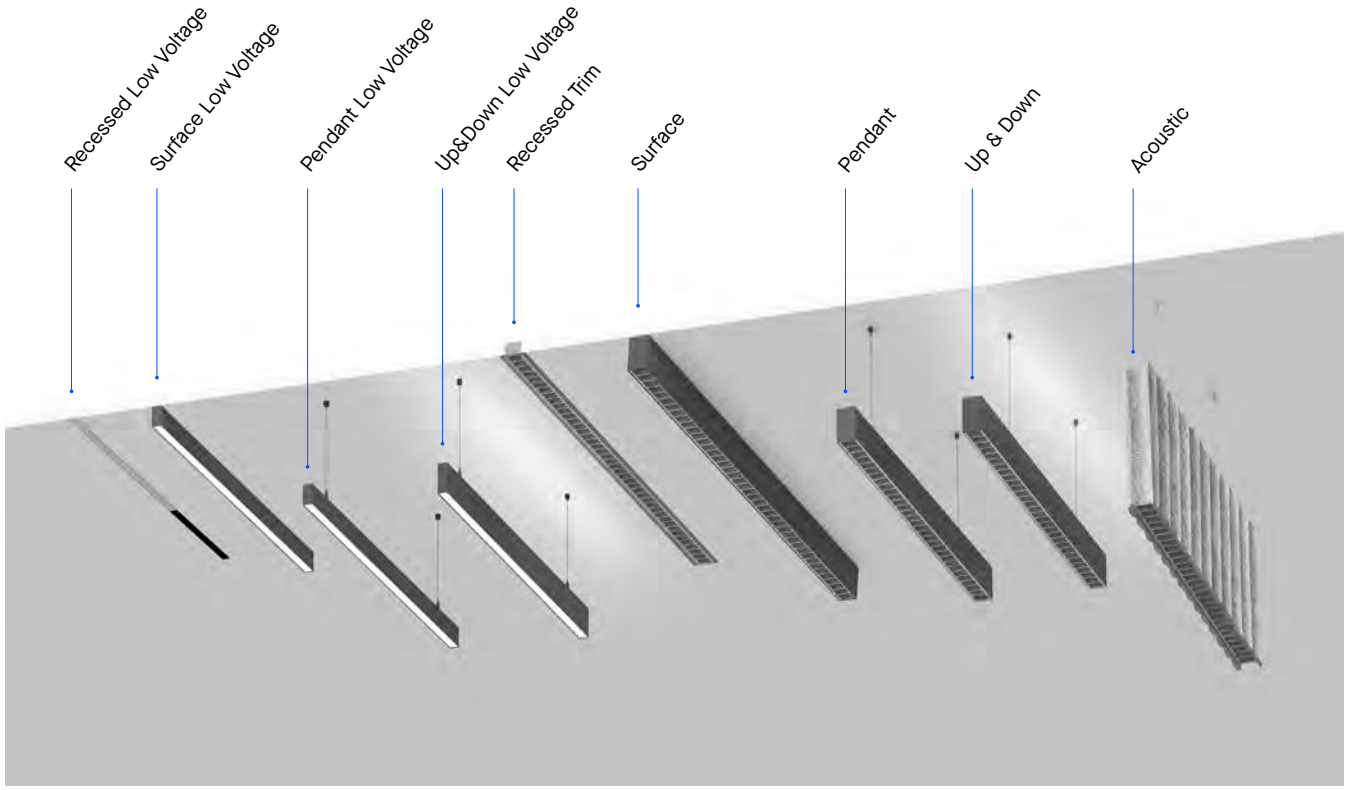

Smart functionality Fonctionnalité Smart

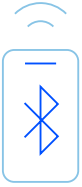

D4i technology enables occupancy monitoring, maximising the efficiency of spaces, adapting and redistributing them according to the needs of each situation and making decisions based on people's needs.

La technologie D4i permet de contrôler l'occupation, de maximiser l'efficacité des espaces, de les adapter et de les redistribuer en fonction des besoins de chaque situation et de prendre des décisions en fonction des besoins des personnes.

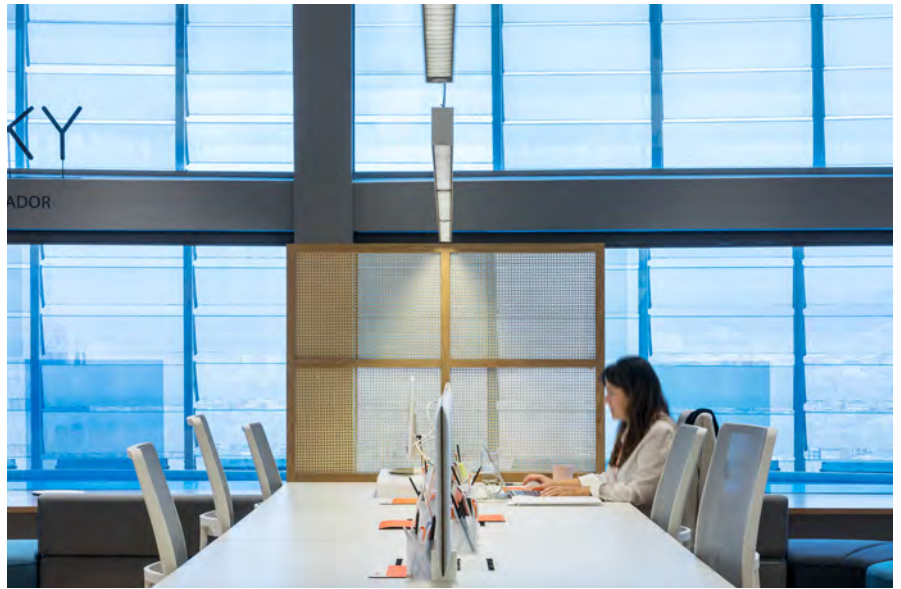

80% intensity. Occupied setting.
Intensité 80 %. Scène en mode occupé.



25% intensity. Unoccupied setting.
Intensité 25 %. Scène en mode non occupé.

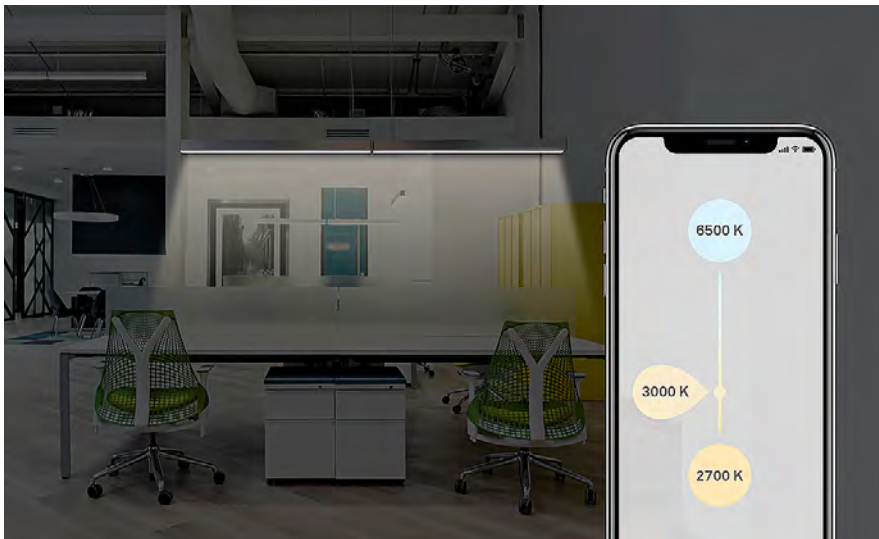

Tunable White option that regulates the colour temperature simulating natural light
Option Tunable White qui règle la température de couleur en simulant la lumière naturelle



Versions available without light and with Opal, Opticell, Microprismatic and Hexacell lenses.
 Versions disponibles sans éclairage et avec optiques Opal, Opticell, Microprismatic et Hexacell.

Infinite Pro Acoustic is made with sound-absorbing materials that reduce background noise
 Infinite Pro Acoustic est fabriqué à base de matériaux insonorisants qui atténuent le bruit ambiant

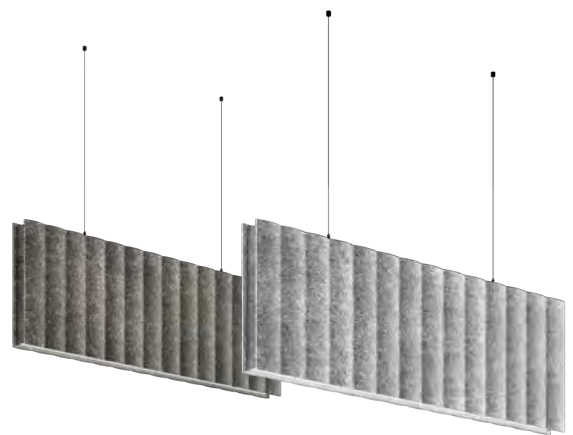

Rating according to ISO 11654: 1997 Weighted sound absorbing coefficient, $\alpha_w=0.95$ Sound absorption class: Class A.

Infinite Pro models come with the ENEC certification, attesting to the product's quality and safety in compliance with European standards.
 Les modèles Infinite Pro bénéficient du label ENEC qui démontre la qualité et la sécurité du produit conformément aux normes européennes.





Built-in sensor to adjust the light based on brightness provided by natural light and room occupancy.

Capteur intégré permettant de réguler la lumière en fonction de l'apport de lumière naturelle et de la présence de personnes.

Infinite Pro configurator

Configurateur Infinite Pro



infinite.leds-c4.com

Infinite configuration options in a quick and easy way thanks to our online configurator.

Une infinité d'options de configuration de manière simple et rapide grâce à notre configurateur en ligne.



1 Installation selection

Sélection de l'installation



2 Diffuser selection

Sélection du diffuseur

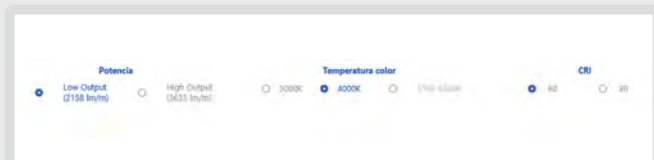

3 LED selection

Sélection des LEDS

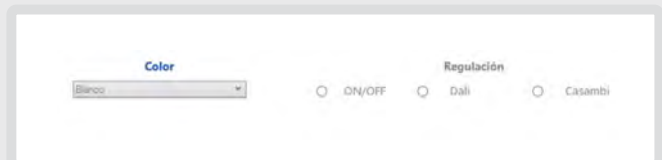

4 Property selection

Sélection des propriétés



5 Documentation download

Télécharger de la documentation

6 Download documentation

Télécharger la documentation

Code exemple / Exemple d'élaboration d'une référence: **AK11-15W8PMOS14**

Model		W	K	CRI	Real Lm	Source	Finishes	
854 mm	 AK11 - Surface 	15W8PM	13.8	3000	80	1920	OS ON-OFF 220-240V	14
		15W9PM	13.8	3000	90	1555	DS DALI-2 220-240V	60
		15X8PM	13.8	4000	80	2042		N3
		15X9PM	13.8	4000	90	1654		
	 AK12 - Pendant 	26W8PM	24.9	3000	80	3199	OS ON-OFF 220-240V	
		26W9PM	24.9	3000	90	2591	DS DALI-2 220-240V	
		26X8PM	24.9	4000	80	3404	XB CASAMBI 220-240V	
		26X9PM	24.9	4000	90	2757	WR DALI D4i 220-240V	
	 AK13 - Recessed 0-25 mm 860x65 	26U8PM	26.6	TW 2700-6500	80	2904	TW DALI DT8 220-240V	
							XA DALI D4i + TW 220-240V	
							XC CASAMBI + TW 220-240V	
1136 mm	 AK14 - Surface 	2PW8PM	18.1	3000	80	2559	OU ON-OFF 100-277V	14
		2PW9PM	18.1	3000	90	2073	OS ON-OFF 220-240V	60
		2PX8PM	18.1	4000	80	2723	DS DALI-2 220-240V	N3
		2PX9PM	18.1	4000	90	2205		GA
	 AK15 - Pendant 0-25 mm 1140x65 	34W8PM	32.6	3000	80	4266	OU ON-OFF 100-277V	GB
		34W9PM	32.6	3000	90	3455	OS ON-OFF 220-240V	
		34X8PM	32.6	4000	80	4538	DS DALI-2 220-240V	
		34X9PM	32.6	4000	90	3676	XB CASAMBI 220-240V	
	 AK16 - Recessed 	35U8PM	35.5	TW 2700-6500	80	3877	TW DALI DT8 220-240V	
							XA DALI D4i + TW 220-240V	
							XC CASAMBI + TW 220-240V	
 AK23 - Acoustic / Pendant 								
1700 mm	 AK18 - Surface 	3PW8PM	27.1	3000	80	3839	OS ON-OFF 220-240V	14
		3PW9PM	27.1	3000	90	3110	DS DALI-2 220-240V	60
		3PX8PM	27.1	4000	80	4084		N3
		3PX9PM	27.1	4000	90	3308		
	 AK21 - Pendant 	52W8PM	48.8	3000	80	6399	OS ON-OFF 220-240V	
		52W9PM	48.8	3000	90	5183	DS DALI-2 220-240V	
		52X8PM	48.8	4000	80	6807	XB CASAMBI 220-240V	
		52X9PM	48.8	4000	90	5514	WR DALI D4i 220-240V	
	 AK19 - Recessed 0-25 mm 1705x65 	53U8PM	53.3	TW 2700-6500	80	3877	TW DALI DT8 220-240V	
							XA DALI D4i + TW 220-240V	
							XC CASAMBI + TW 220-240V	

Infinite Pro
Up&Down Opal

IP	BODY MAT	DIF MAT		3		
40	AL	PC		MacAdam		

Code example / Exemple d'élaboration d'une référence: **AK24-2PWBPMOS14**

Model	W	K	CRI	Real Lm	Source	Finishes	
 AK24 - Pendant 1136 mm	2PQBPM	26.6↑ 17.1↓	3000↑ 4000↓	80 90	6640	OU ON-OFF 100-277V	14
	2PRBPM	26.6↑ 17.1↓	4000↑ 3000↓	80 90	6774	OS ON-OFF 220-240V	60
	2PWBPM	26.6↑ 17.1↓	3000↑ 3000↓	80 90	6508	DS DALI-2 220-240V	N3
	2PXBPM	26.6↑ 17.1↓	4000↑ 4000↓	80 90	6906		
	34QBPM	26.6↑ 30.34↓	3000↑ 4000↓	80 90	8111	OU ON-OFF 100-277V	
	34RBPM	26.6↑ 30.34↓	4000↑ 3000↓	80 90	8156	OS ON-OFF 220-240V	
	34WBPM	26.6↑ 30.34↓	3000↑ 3000↓	80 90	7890	DS DALI-2 220-240V	
	34XBPM	26.6↑ 30.34↓	4000↑ 4000↓	80 90	8377	WR DALI D4i 220-240V	
	35U8PM	42.3↑ 50.7↓	TW 2700-6500	80	6963	TW DALI DT8 220-240V XA DALI D4i + TW 220-240V	
	 AK25 - Pendant 1700 mm	3PQBPM	41.8↑ 25.6↓	3000↑ 4000↓	80 90	10278	OS ON-OFF 220-240V
3PRBPM		41.8↑ 25.6↓	4000↑ 3000↓	80 90	9826	DS DALI-2 220-240V	60
3PWBPM		41.8↑ 25.6↓	3000↑ 3000↓	80 90	10080		N3
3PXBPM		41.8↑ 25.6↓	4000↑ 4000↓	80 90	10024		
52QBPM		41.8↑ 45.6↓	3000↑ 4000↓	80 90	12484	OS ON-OFF 220-240V	
52RBPM		41.8↑ 45.6↓	4000↑ 3000↓	80 90	11899	DS DALI-2 220-240V	
52WBPM		41.8↑ 45.6↓	3000↑ 3000↓	80 90	12153	XB CASAMBI 220-240V	
52XBPM		41.8↑ 45.6↓	4000↑ 4000↓	80 90	12230	WR DALI D4i 220-240V	
53U8PM		42.3↑ 50.7↓	TW 2700-6500	80	11042	TW DALI DT8 220-240V XA DALI D4i + TW 220-240V XC CASAMBI + TW 220-240V	

Infinite Pro
Opal
854mm

Infinite Pro
Opal
1136mm

Infinite Pro
Opal
1700mm

Lens accessories
Accessoires optiques



Microprismatic diffuser
Diffuseur microprismatique

71-A938-00-00

71-A939-00-00

71-A940-00-00

IP
40

BODY MAT
AL

UGR
<19

DIF MAT
PC











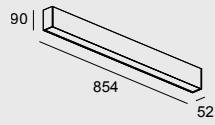

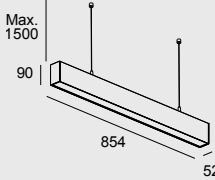

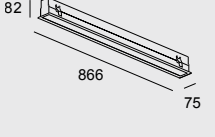







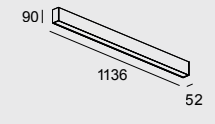

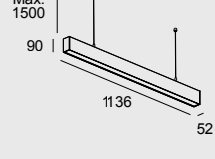

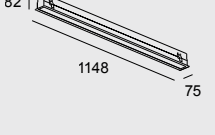









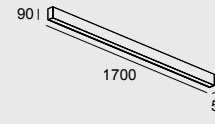

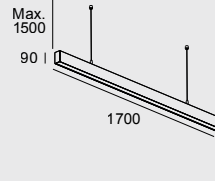

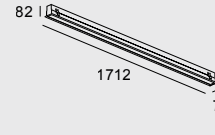
50000h
L80 B20

3
MacAdam



Code exemple / Exemple d'élaboration d'une référence: **AK11-15W8PMOS14**

Model	W	K	CRI	Real Lm	Source	Finishes	
854 mm  AK11 - Surface   AK12 - Pendant   AK13 - Recessed 0-25 mm 860x65 	1PW8HP	10.4	3000	80	1345	OS  ON-OFF 220-240V	14 
	1PW9HP	10.4	3000	80	1090	DS  DALI-2 220-240V	60 
	1PX8HP	10.4	4000	80	1431	XB  CASAMBI 220-240V	N3 
	1PX9HP	10.4	4000	90	1159		
1136 mm  AK14 - Surface   AK15 - Pendant   AK16 - Recessed 0-25 mm 1140x65 	13W8HP	13.5	3000	80	1794	OS  ON-OFF 220-240V	14 
	13W9HP	13.5	3000	90	1453	DS  DALI-2 220-240V	60 
	13X8HP	13.5	4000	80	1908	WR  DALI D4i 220-240V	N3 
	13X9HP	13.5	4000	90	1545	XB  CASAMBI 220-240V	GA  GB 
1700 mm  AK18 - Surface   AK21 - Suspended   AK19 - Recessed 0-25 mm 1705x65 	19W8HP	20.3	3000	80	2690	OS  ON-OFF 220-240V	14 
	19W9HP	20.3	3000	90	2179	DS  DALI-2 220-240V	60 
	19X8HP	20.3	4000	80	2862	WR  DALI D4i 220-240V	N3 
	19X9HP	20.3	4000	90	2318	XB  CASAMBI 220-240V	

Infinite Pro
Up&Down Haloprisma

IP	BODY MAT	DIF MAT			
40	AL	PC			

Code example / Exemple d'élaboration d'une référence: **AK24-2PWBPMS14**

Model		W	K	CRI	Real Lm	Source	Finishes
AK24 - Pendant 14 60 N3 	13QBHP	26.5↑ 12.6↓	3000↑ 4000↓	80 90	5980	OS ON-OFF 220-240V	14
	13RBHP	26.5↑ 12.6↓	4000↑ 3000↓	80 90	6154	DS DALI-2 220-240V	60
	13WBHP	26.5↑ 12.6↓	3000↑ 3000↓	80 90	5888	WR DALI D4i 220-240V	N3
	13XBHP	26.5↑ 12.6↓	4000↑ 4000↓	80 90	6246		
AK25 - Pendant 14 60 N3 	19QBHP	41.8↑ 19↓	3000↑ 4000↓	80 90	9288	OS ON-OFF 220-240V	14
	19RBHP	41.8↑ 19↓	4000↑ 3000↓	80 90	8895	DS DALI-2 220-240V	60
	19WBHP	41.8↑ 19↓	3000↑ 3000↓	80 90	9149	XB CASAMBI 220-240V	N3
	19XBHP	41.8↑ 19↓	4000↑ 4000↓	80 90	9034	WR DALI D4i 220-240V	

IP
40

BODY MAT
AL

UGR
<16

DIF MAT
PC











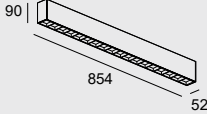
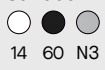
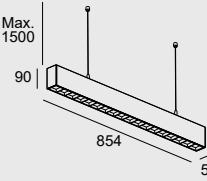
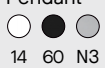
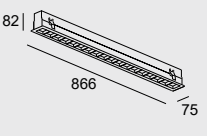











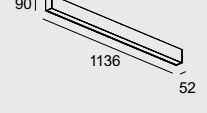
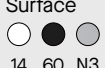
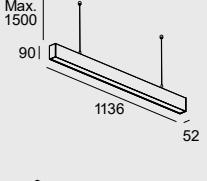



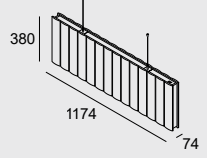

















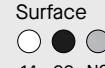
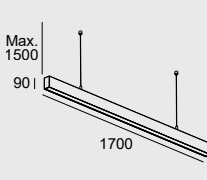
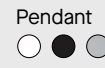
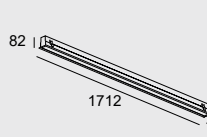



50000h
L80 B20

3
MacAdam



Code example / Exemple d'élaboration d'une référence: **AK11-12W8CLOS14**

Model	W	K	CRI	Real Lm	Source	Finishes	
854 mm  AK11 - Surface  14 60 N3  AK12 - Pendant  14 60 N3  AK13 - Recessed 0-25 mm 860x65  14	12W8CL	11.2	3000	80	1751	OS  ON-OFF 220-240V	14 
	12W9CL	11.2	3000	90	1751	DS  DALI-2 220-240V	60 
	12X8CL	11.2	4000	80	1751		N3 
	12X9CL	11.2	4000	90	1751		
	24W8CL	24.4	3000	80	3381	OS  ON-OFF 220-240V	
	24W9CL	24.4	3000	90	3381	DS  DALI-2 220-240V	
	24X8CL	24.4	4000	80	3381	XB  CASAMBI 220-240V	↔
	24X9CL	24.4	4000	90	3381	WR  DALI D4i 220-240V	
	18U8CL	16.8	TW 2700-6500	80	2630	TW  DALI DT8 220-240V	
					XA  DALI D4i + TW 220-240V		
1136 mm  AK14 - Surface  14 60 N3  AK15 - Pendant  14 60 N3  AK16 - Recessed 0-25 mm 1140x65  14  AK23 - Acoustic / Pendant  GA GB	16W8CL	15.8	3000	80	2280	OS  ON-OFF 220-240V	14 
	16W9CL	15.8	3000	90	2052	DS  DALI-2 220-240V	60 
	16X8CL	15.8	4000	80	2381		N3 
	16X9CL	15.8	4000	90	2052		GA 
	32W8CL	32.6	3000	80	4402	OU  ON-OFF 100-277V	GB 
	32W9CL	32.6	3000	90	4402	OS  ON-OFF 220-240V	
	32X8CL	32.6	4000	80	4402	DS  DALI-2 220-240V	
	32x9CL	32.6	4000	90	4402	XB  CASAMBI 220-240V	↔
						WR  DALI D4i 220-240V	
	24U8CL	22.4	TW 2700-6500	80	3424	TW  DALI DT8 220-240V	
						XA  DALI D4i + TW 220-240V	
						XC  CASAMBI + TW 220-240V	↔
1700 mm  AK18 - Surface  14 60 N3  AK21 - Pendant  14 60 N3  AK19 - Recessed 0-25 mm 1705x65  14	24W8CL	23.7	3000	80	3502	OS  ON-OFF 220-240V	14 
	24W9CL	23.7	3000	90	3152	DS  DALI-2 220-240V	60 
	24X8CL	23.7	4000	80	3657		N3 
	24X9CL	23.7	4000	90	3152		
	48W8CL	48.9	3000	80	6762	OS  ON-OFF 220-240V	
	48W9CL	48.9	3000	90	6086	DS  DALI-2 220-240V	
	48X8CL	48.9	4000	80	7060	XB  CASAMBI 220-240V	↔
	48X9CL	48.9	4000	90	6086		
	36U8CL	33.7	TW 2700-6500	80	5259	TW  DALI DT8 220-240V	
					XC  CASAMBI + TW 220-240V	↔	

Infinite Pro
Up&Down Opticell

IP
40

BODY MAT
AL

DIF MAT
PC



3
MacAdam



Code example / Exemple d'élaboration d'une référence: **AK24-16WBCL0S14**

Model	W	K	CRI	Real Lm	Source	Finishes	
<p>AK24 - Pendant ○ ● ● 14 60 N3</p>	16QBCL	26.1↑ 14.4↓	3000↑ 4000↓	80 90	6487	OS ON-OFF 220-240V	14 ○
	16RBCL	26.1↑ 14.4↓	4000↑ 3000↓	90 90	6753	DS DALI-2 220-240V	60 ●
	16WBCL	26.1↑ 14.4↓	3000↑ 3000↓	80 90	6487		N3 ●
	16XBCL	26.1↑ 14.4↓	4000↑ 4000↓	90 90	6753		
	32QBCL	26.1↑ 29.4↓	3000↑ 4000↓	80 90	7994	OU ON-OFF 100-277V	
	32RBCL	26.1↑ 29.4↓	4000↑ 3000↓	90 90	7994	OS ON-OFF 220-240V	
	32WBCL	26.1↑ 29.4↓	3000↑ 3000↓	80 90	7994	DS DALI-2 220-240V	
	32XBCL	26.1↑ 29.4↓	4000↑ 4000↓	80 90	7994	WR DALI D4i 220-240V	
	24U8CL	25.4↑ 21.4↓	TW 2700-6500	80	6510	TW DALI DT8 220-240V	
	<p>AK25 - Pendant ○ ● ● 14 60 N3</p>	24QBCL	41.1↑ 21.4↓	3000↑ 4000↓	80 90	10122	OS ON-OFF 220-240V
24RBCL		41.1↑ 21.4↓	4000↑ 3000↓	80 90	9868	DS DALI-2 220-240V	60 ●
24WBCL		41.1↑ 21.4↓	3000↑ 3000↓	80 90	10122		N3 ●
24XBCL		41.1↑ 21.4↓	4000↑ 4000↓	80 90	9868		
48QBCL		41.1↑ 44↓	3000↑ 4000↓	80 90	13306	OS ON-OFF 220-240V	
48RBCL		41.1↑ 44↓	4000↑ 3000↓	80 90	13457	DS DALI-2 220-240V	
48WBCL		41.1↑ 44↓	3000↑ 3000↓	80 90	13306	XB CASAMBI 220-240V	⚡
48XBCL		41.1↑ 44↓	4000↑ 4000↓	80 90	13457		
36U8CL	42.3↑ 50.7↓	TW 2700-6500	80	10392	TW DALI DT8 220-240V		
					XC CASAMBI + TW 220-240V	⚡	

Model	W	K	CRI	Real Lm	Source	Finishes	
<p>854 mm</p> <p>AK11 - Surface ○ ● ● N3 14 60 N3</p> <p>AK12 - Pendant ○ ● ● N3 14 60 N3</p> <p>AK13 - Recessed 0-25 mm 860x65 ○ 14</p>	15W8HC	13.8	3000	80	633	OS ON-OFF 220-240V	14 ○
	15W9HC	13.8	3000	90	513	DS DALI-2 220-240V	60 ●
	15X8HC	13.8	4000	80	674		N3 ●
	15X9HC	13.8	4000	90	546		
	26W8HC	24.9	3000	80	1056	OS ON-OFF 220-240V	
	26W9HC	24.9	3000	90	855	DS DALI-2 220-240V	
	26X8HC	24.9	4000	80	1123	XB CASAMBI 220-240V	⚡
	26X9HC	24.9	4000	90	910	WR DALI D4i 220-240V	
	26U8HC	26.6	TW 2700-6500		1012	TW DALI DT8 220-240V	
						XA DALI D4i + TW 220-240V	
					XC CASAMBI + TW 220-240V	⚡	
<p>1136 mm</p> <p>AK14 - Surface ○ ● ● N3 14 60 N3</p> <p>AK15 - Pendant ○ ● ● N3 14 60 N3</p> <p>AK16 - Recessed 0-25 mm 1140x65 ○ 14</p> <p>AK23 - Acoustic / Pendant ● ● GA GB</p>	2PW8HC	18.1	3000	80	845	OU ON-OFF 100-277V	14 ○
	2PW9HC	18.1	3000	90	684	OS ON-OFF 220-240V	60 ●
	2PX8HC	18.1	4000	80	899	DS DALI-2 220-240V	N3 ●
	2PX9HC	18.1	4000	90	728		GA ●
	34W8HC	32.6	3000	80	1408	OU ON-OFF 100-277V	GB ●
	34W9HC	32.6	3000	90	1140	OS ON-OFF 220-240V	
	34X8HC	32.6	4000	80	1498	DS DALI-2 220-240V	
	34X9HC	32.6	4000	90	1213	XB CASAMBI 220-240V	⚡
	35U8HC	35.5	TW 2700-6500		1347	WR DALI D4i 220-240V	
						TW DALI DT8 220-240V	
					XA DALI D4i + TW 220-240V		
					XC CASAMBI + TW 220-240V	⚡	
<p>1700 mm</p> <p>AK18 - Surface ○ ● ● N3 14 60 N3</p> <p>AK21 - Pendant ○ ● ● N3 14 60 N3</p> <p>AK19 - Recessed 0-25 mm 1705x65 ○ 14</p>	3PW8HC	27.1	3000	80	1267	OS ON-OFF 220-240V	14 ○
	3PW9HC	27.1	3000	90	1026	DS DALI-2 220-240V	60 ●
	3PX8HC	27.1	4000	80	1348		N3 ●
	3PX9HC	27.1	4000	90	1092		
	52W8HC	48.8	3000	80	2112	OS ON-OFF 220-240V	
	52W9HC	48.8	3000	90	1710	DS DALI-2 220-240V	
	52X8HC	48.8	4000	80	2246	XB CASAMBI 220-240V	⚡
	52X9HC	48.8	4000	90	1820	WR DALI D4i 220-240V	
	53U8HC	53.3	TW 2700-6500		2024	TW DALI DT8 220-240V	
						XA DALI D4i + TW 220-240V	
					XC CASAMBI + TW 220-240V	⚡	

Infinite Pro
Up&Down Hexa-Cell

IP
40

BODY MAT
AL

UGR
<10

DIF MAT
PC



50000h
L80 B20

3
MacAdam



Code example / Exemple d'élaboration d'une référence: **AK24-2PWBHCOS14**

Model	W	K	CRI	Real Lm	Source	Finishes		
<div style="display: flex; align-items: center;"> <div style="writing-mode: vertical-rl; transform: rotate(180deg); margin-right: 10px;">1136 mm</div> <div style="text-align: center;"> <p>AK24 - Pendant</p> <p>○ ● ●</p> <p>14 60 N3</p> </div> </div>	2PQBHC	26.6↑ 17.1↓	3000↑ 4000↓	80 90	5163	OU ON-OFF 100-277V	14 ○	
	2PRBHC	26.6↑ 17.1↓	4000↑ 3000↓	80 90	5385	OS ON-OFF 220-240V	60 ●	
	2PWBHC	26.6↑ 17.1↓	3000↑ 3000↓	80 90	5119	DS DALI-2 220-240V	N3 ●	
	2PXBHC	26.6↑ 17.1↓	4000↑ 4000↓	80 90	5429			
	34QBHC	26.6↑ 30.4↓	3000↑ 4000↓	80 90	5648	OU ON-OFF 100-277V		
	34RBHC	26.6↑ 30.4↓	4000↑ 3000↓	80 90	5841	OS ON-OFF 220-240V		
	34WBHC	26.6↑ 30.4↓	3000↑ 3000↓	80 90	5575	DS DALI-2 220-240V		
	34XBHC	26.6↑ 30.4↓	4000↑ 4000↓	80 90	5914	WR DALI D4i 220-240V		
	35U8HC	25.4↑ 33.8↓	TW 2700-6500	80	4433	TW DALI DT8 220-240V		
						XA DALI D4i + TW 220-240V		
	<div style="display: flex; align-items: center;"> <div style="writing-mode: vertical-rl; transform: rotate(180deg); margin-right: 10px;">1700 mm</div> <div style="text-align: center;"> <p>AK25 - Pendant</p> <p>○ ● ●</p> <p>14 60 N3</p> </div> </div>	3PQBHC	41.8↑ 25.6↓	3000↑ 4000↓	80 90	8062	OS ON-OFF 220-240V	14 ○
		3PRBHC	41.8↑ 25.6↓	4000↑ 3000↓	80 90	7742	DS DALI-2 220-240V	60 ●
		3PWBHC	41.8↑ 25.6↓	3000↑ 3000↓	80 90	7996		N3 ●
		3PXBHC	41.8↑ 25.6↓	4000↑ 4000↓	80 90	7808		
52QBHC		41.8↑ 45.6↓	3000↑ 4000↓	80 90	8790	OS ON-OFF 220-240V		
52RBHC		41.8↑ 45.6↓	4000↑ 3000↓	80 90	8426	DS DALI-2 220-240V		
52WBHC		41.8↑ 45.6↓	3000↑ 3000↓	80 90	8680	XB CASAMBI 220-240V	⊗	
52XBHC		41.8↑ 45.6↓	4000↑ 4000↓	80 90	8536	WR DALI D4i 220-240V		
53U8HC		42.3↑ 50.7↓	TW 2700-6500	80	7157	TW DALI DT8 220-240V		
						XA DALI D4i + TW 220-240V		
						XC CASAMBI + TW 220-240V	⊗	

Infinite Pro
Lens 90°

IP	BODY MAT		50000h	
40	AL		L80 B20	

Code example / Exemple d'élaboration d'une référence: **AK14-2PW8R20S14**

Model	W	K	CRI	Real Lm	Source	Finishes		
 AK14 - Surface AK15 - Pendant AK16 - Recessed 0-25 mm 1140x65 1136 mm	2PW8L9	18.1	3000	80	2995	OU ON-OFF 100-277V	14	
	2PW9L9	18.1	3000	90	2426	OS ON-OFF 220-240V	60	
	2PX8L9	18.1	4000	80	3186	DS DALI-2 220-240V	N3	
	2PX9L9	18.1	4000	90	2580			
	34W8L9	32.6	3000	80	4991	OU ON-OFF 100-277V		
	34W9L9	32.6	3000	90	4043	OS ON-OFF 220-240V		
	34X8L9	32.6	4000	80	5309	DS DALI-2 220-240V		
	34X9L9	32.6	4000	90	4301			
	 AK24 - Pendant Up&Down 	2PQBL9	26.6↑ 17.1↓	3000↑ 4000↓	90	7015	OU ON-OFF 100-277V	14
		2PRBL9	26.6↑ 17.1↓	4000↑ 3000↓	90	7127	OS ON-OFF 220-240V	60
		2PWBL9	26.6↑ 17.1↓	3000↑ 3000↓	90	6861		N3
		2PXBL9	26.6↑ 17.1↓	4000↑ 4000↓	90	7281		
34QBL9		26.6↑ 30.4↓	3000↑ 4000↓	90	8736	OU ON-OFF 100-277V		
34RBL9		26.6↑ 30.4↓	4000↑ 3000↓	90	8744	OS ON-OFF 220-240V		
34WBL9		26.6↑ 30.4↓	3000↑ 3000↓	90	8478	DS DALI-2 220-240V		
34XBL9		26.6↑ 30.4↓	4000↑ 4000↓	90	9002			

Infinite Pro
Lens Batwing

IP
40



BODY MAT
AL



50000h
L80 B20

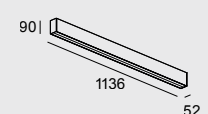
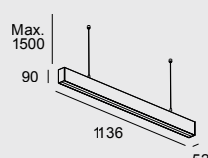
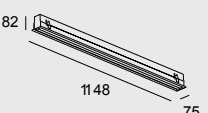
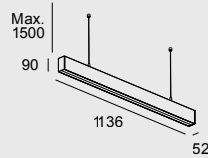

Code example / Exemple d'élaboration d'une référence: **AK14-2PW8R20S14**

Model	W	K	CRI	Real Lm	Source	Finishes
<div style="display: flex; flex-direction: column; align-items: flex-start;"> <div style="margin-bottom: 10px;">  <p>AK14 - Surface ○ ● ● 14 60 N3</p> </div> <div style="margin-bottom: 10px;">  <p>AK15 - Pendant ○ ● ● 14 60 N3</p> </div> <div style="margin-bottom: 10px;">  <p>AK16 - Recessed 0-25 mm 1140x65 ○ 14</p> </div> <div style="margin-bottom: 10px;">  <p>AK24 - Pendant Up&Down ○ ● ● 14 60 N3</p> </div> <div style="margin-bottom: 10px;">  </div> </div> <p style="writing-mode: vertical-rl; transform: rotate(180deg);">1136 mm</p>	<p>2PW8B2 18.1 3000 80 2943 OU ON-OFF 100-277V</p> <p>2PW9B2 18.1 3000 90 2384 OS ON-OFF 220-240V</p> <p>2PX8B2 18.1 4000 80 3131 DS DALI-2 220-240V</p> <p>2PX9B2 18.1 4000 90 2536</p>	<p>34W8B2 32.6 3000 80 4906 OU ON-OFF 100-277V</p> <p>34W9B2 32.6 3000 90 3974 OS ON-OFF 220-240V</p> <p>34X8B2 32.6 4000 80 5219 DS DALI-2 220-240V</p> <p>34X9B2 32.6 4000 90 4227</p>	<p>2PQBB2 26.6↑ 3000↑ 90 6971 OU ON-OFF 100-277V</p> <p>2PRBB2 26.6↑ 4000↑ 90 7085 OS ON-OFF 220-240V</p> <p>2PWBB2 26.6↑ 3000↑ 90 6819</p> <p>2PXBB2 26.6↑ 4000↑ 90 7237</p>	<p>34QBB2 26.6↑ 3000↑ 90 8662 OU ON-OFF 100-277V</p> <p>34RBB2 26.6↑ 4000↑ 90 8675 OS ON-OFF 220-240V</p> <p>34WBB2 26.6↑ 3000↑ 90 8409 DS DALI-2 220-240V</p> <p>34XBB2 26.6↑ 4000↑ 90 8928</p>	<p>14 ○</p> <p>60 ●</p> <p>N3 ●</p>	

**Infinite Pro
Lens Elliptic**

IP	BODY MAT		50000h		
40	AL		L80 B20		

Code example / Exemple d'élaboration d'une référence: **AK14-2PW8R20S14**

Model		W	K	CRI	Real Lm	Source	Finishes	
 AK14 - Surface AK15 - Pendant AK16 - Recessed 0-25 mm 1140x65 1136 mm	2PW8E2	18.1	3000	80	3123	OU ON-OFF 100-277V	14	
	2PW9E2	18.1	3000	90	2529	OS ON-OFF 220-240V	60	
	2PX8E2	18.1	4000	80	3322	DS DALI-2 220-240V	N3	
	2PX9E2	18.1	4000	90	2691			
	34W8E2	32.6	3000	80	5204	OU ON-OFF 100-277V		
	34W9E2	32.6	3000	90	4215	OS ON-OFF 220-240V		
	34X8E2	32.6	4000	80	5536	DS DALI-2 220-240V		
	34X9E2	32.6	4000	90	4484			
	 AK24 - Pendant Up&Down 	2PQB2	26.6↑ 17.1↓	3000↑ 4000↓	90	7126	OU ON-OFF 100-277V	14
		2PRB2	26.6↑ 17.1↓	4000↑ 3000↓	90	7230	OS ON-OFF 220-240V	60
		2PWBE2	26.6↑ 17.1↓	3000↑ 3000↓	90	6964		N3
		2PXB2	26.6↑ 17.1↓	4000↑ 4000↓	90	7392		
34QB2		26.6↑ 30.4↓	3000↑ 4000↓	90	8919	OU ON-OFF 100-277V		
34RB2		26.6↑ 30.4↓	4000↑ 3000↓	90	8916	OS ON-OFF 220-240V		
34WBE2		26.6↑ 30.4↓	3000↑ 3000↓	90	8650	DS DALI-2 220-240V		
34XBE2		26.6↑ 30.4↓	4000↑ 4000↓	90	9185			

Infinite Pro
Lens Wallwasher

IP
40



BODY MAT
AL



50000h
L80 B20

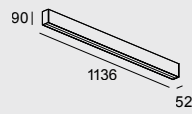
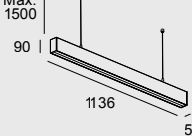
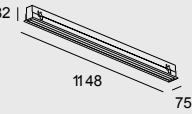
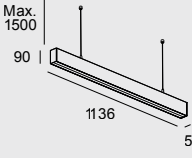

Code example / Exemple d'élaboration d'une référence: **AK14-2PW8R2OS14**

Model	W	K	CRI	Real Lm	Source	Finishes
<div style="display: flex; flex-direction: column; align-items: flex-start;"> <div style="margin-bottom: 10px;">  <p>AK14 - Surface ○ ● ● 14 60 N3</p> </div> <div style="margin-bottom: 10px;">  <p>AK15 - Pendant ○ ● ● 14 60 N3</p> </div> <div style="margin-bottom: 10px;">  <p>AK16 - Recessed ▬ 0-25 mm ▬ 1140×65 ○ 14</p> </div> <div style="margin-bottom: 10px;">  <p>AK24 - Pendant Up&Down ○ ● ● 14 60 N3</p> </div> <div style="margin-bottom: 10px;">  </div> </div> <p style="writing-mode: vertical-rl; transform: rotate(180deg);">1136 mm</p>	<p>2PW8R2 18.1 3000 80 2636</p> <p>2PW9R2 18.1 3000 90 2135</p> <p>2PX8R2 18.1 4000 80 2804</p> <p>2PX9R2 18.1 4000 90 2272</p>	<p>34W8R2 32.6 3000 80 4394</p> <p>34W9R2 32.6 3000 90 3559</p> <p>34X8R2 32.6 4000 80 4674</p> <p>34X9R2 32.6 4000 90 3786</p>	<p>2PQBR2 26.6↑ 3000↑ 90 6707 17.1↓ 4000↓</p> <p>2PRBR2 26.6↑ 4000↑ 90 6836 17.1↓ 3000↓</p> <p>2PWBR2 26.6↑ 3000↑ 90 6570 17.1↓ 3000↓</p> <p>2PXBR2 26.6↑ 4000↑ 90 6973 17.1↓ 4000↓</p>	<p>34QBR2 26.6↑ 3000↑ 90 8221 30.4↓ 4000↓</p> <p>34RBR2 26.6↑ 4000↑ 90 8260 30.4↓ 3000↓</p> <p>34WBR2 26.6↑ 3000↑ 90 7994 30.4↓ 3000↓</p> <p>34XBR2 26.6↑ 4000↑ 90 8487 30.4↓ 4000↓</p>	<p>OU ON-OFF 100-277V</p> <p>OS ON-OFF 220-240V</p> <p>DS DALI-2 220-240V</p>	<p>14 ○</p> <p>60 ●</p> <p>N3 ●</p>

Infinite Pro Track

IP	BODY MAT		50000h	
40	AL		L80 B20	

Code exemple / Exemple d'élaboration d'une référence: **AK14-2PW8R20S14**

Model	W	K	CRI	Real Lm	Source	Finishes		
<p>AK14 - Surface 14 60 N3</p> <p>AK15 - Pendant 14 60 N3</p> <p>AK16 - Recessed 0-25 mm 1140x65 14</p> <p>AK23 - Acoustic / Pendant GA GB</p> <p style="writing-mode: vertical-rl; transform: rotate(180deg);">1136 mm</p>	AACCNA TRACK				BU ON-OFF 100-277V	14 60 N3 GA GB		
	<p>AK24 - Pendant Up&Down 14 60 N3</p>	16WBNA	26.6↑ TRACK↓	3000↑ TRACK↓	90	4435	OU ON-OFF 100-277V	14 60 N3
		16XBNA	26.6↑ TRACK↓	4000↑ TRACK↓	90	4701	OS ON-OFF 220-240V	

	Pendant / Surface ON-OFF (OS / OU / XB / XC / BU)	Pendant / Surface DALI (DS / TW)	Pendant / Surface DALI (WR / XA)
--	---------------------------------------------------------	----------------------------------------	----------------------------------------

Fixing accessories

Accessoires de fixation

	Suspended ceiling rose with electrical outlet ON-OFF + DALI (2500mm)	14 ○	71-7520-14-00	71-7521-14-00	71-7521-14-00
	Patère suspendue avec prise de courant ON-OFF + DALI (2500mm)	60 ●	71-7520-60-00	71-7521-60-00	71-7521-60-00

N3 ○	71-7520-N3-00	71-7521-N3-00	71-7521-N3-00
------	----------------------	----------------------	----------------------

	Accessory for wall installation Accessoire d'installation murale	14 ○	71-7518-14-00	71-7518-14-00	71-7518-14-00
		60 ●	71-7518-60-00	71-7518-60-00	71-7518-60-00
		N3 ○	71-7518-N3-00	71-7518-N3-00	71-7518-N3-00

	Fixed bars 1000mm (2 pcs.) Barres fixes 1000mm (2 u.)	14 ○	71-B637-14-00	71-B637-14-00	71-B637-14-00
		60 ●	71-B637-60-00	71-B637-60-00	71-B637-60-00

	Infinite Pro fixed bar installation extension kit 1000 mm (2 pcs.) Kit d'installation barres fixes Infinite Pro 1 000 mm (2 u.)	14 ○	71-B504-14-00	71-B504-14-00	71-B504-14-00
		60 ●	71-B504-60-00	71-B504-60-00	71-B504-60-00

Joint accessories

Accessoires de raccord

	ON-OFF + DALI 90° joint Raccord 90° ON-OFF + DALI	14 ○	71-8113-14-00	71-8113-14-DA	71-8113-14-DA
		60 ●	71-8113-60-00	71-8113-60-DA	71-8113-60-DA
		N3 ○	71-8113-N3-00	71-8113-N3-DA	71-8113-N3-DA

	ON-OFF + DALI "I" union kit Kit de raccord en "I" ON-OFF + DALI		71-A955-00-00	71-A955-00-DA	71-A955-00-DA
-------------------------------------------------------------------------------------	--------------------------------------------------------------------	--	----------------------	----------------------	----------------------

Sensors

Capteurs

	Standalone Sensor Capteur Standalone	14 ○	-	71-A995-14-SE	71-A995-14-SE
		60 ●	-	71-A995-60-SE	71-A995-60-SE
		N3 ○	-	71-A995-N3-SE	71-A995-N3-SE

	Sensor DALI D4i Connected Capteur DALI D4i Connected	14 ○	-	-	71-7735-14-SE
		60 ●	-	-	71-7735-60-SE
		N3 ○	-	-	71-7735-N3-SE

	DALI D4i One sensor Capteur DALI D4i One	14 ○	-	-	71-A263-14-SE
		60 ●	-	-	71-A263-60-SE
		N3 ○	-	-	71-A263-N3-SE

Recessed ON-OFF (OS / OU / XB / XC)	Recessed DALI (DS / WR / XA / TW)	Up&Down ON-OFF (OS / OU / XB / XC / NA)	Up&Down DALI (DS / TW)	Up&Down DALI (WR / XA)
Fixing accessories Accessoires de fixation				
-	-	71-7520-14-00	71-7521-14-00	71-7521-14-00
-	-	71-7520-60-00	71-7521-60-00	71-7521-60-00
-	-	71-7520-N3-00	71-7521-N3-00	71-7521-N3-00
-	-	-	-	-
-	-	-	-	-
-	-	-	-	-
-	-	71-B638-14-00	71-B638-14-00	71-B638-14-00
-	-	71-B638-60-00	71-B638-60-00	71-B638-60-00
-	-	71-B504-14-00	71-B504-14-00	71-B504-14-00
-	-	71-B504-60-00	71-B504-60-00	71-B504-60-00
Joint accessories Accessoires de raccord				
71-8112-14-00	71-8112-14-DA	71-8114-14-00	71-8114-14-DA	71-8114-14-DA
-	-	71-8114-60-00	71-8114-60-DA	71-8114-60-DA
-	-	71-8114-N3-00	71-8114-N3-DA	71-8114-N3-DA
71-A955-00-00	71-A955-00-DA	71-A956-00-00	71-A956-00-DA	71-A956-00-DA
Sensors Capteurs				
-	-	-	71-A996-14-SE	71-A996-14-SE
-	-	-	71-A996-60-SE	71-A996-60-SE
-	-	-	71-A996-N3-SE	71-A996-N3-SE
-	-	-	-	71-7736-14-SE
-	-	-	-	71-7736-60-SE
-	-	-	-	71-7736-N3-SE
-	-	-	-	71-A264-14-SE
-	-	-	-	71-A264-60-SE
-	-	-	-	71-A264-N3-SE

Infinite Slim



+ Infinite Slim



Miniaturisation and integrating lighting Miniaturisation et éclairage intégratif

Workspaces are becoming more demanding. Miniaturisation and integrating lighting are fundamental features that have become a trend to enhance working environments and people's well-being at work. With a high light package and super-extensive lens in a body only 25 mm wide, Infinite Slim is a trend in itself.

Les espaces de travail sont de plus en plus exigeants. La miniaturisation et l'intégration de l'éclairage sont des caractéristiques fondamentales qui sont devenues tendance pour favoriser l'environnement de travail et le bien-être des personnes. Doté d'une charge lumineuse élevée et d'une optique très extensive dans un corps de seulement 25 mm de large, Infinite Slim est une tendance à part entière.

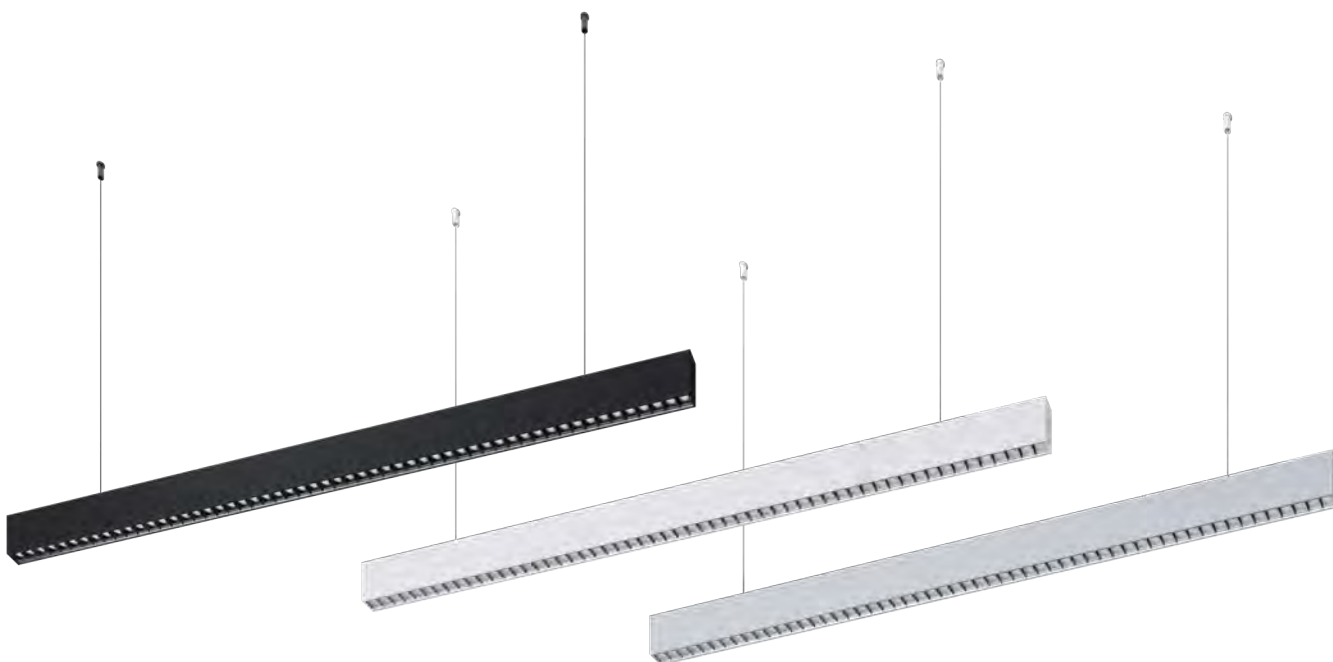



Adaptable to the space Adaptable à l'espace

Surface-mounted, suspended or recessed, Infinite Slim is the perfect solution to match the architectural concept of the space. With the new 90° modules, changes of direction can be generated allowing the linear to follow the precise structure of the area to be illuminated.

En saillie, suspendu ou encastré, Infinite Slim est la solution parfaite pour s'adapter au concept architectural de l'espace. Avec les nouveaux modules à 90°, il est possible de générer des changements de direction permettant au linéaire de suivre la structure précise de la zone à éclairer.



90°

Surface
SurfaceSuspended
SuspenduRecessed
Encastré

Click & Go

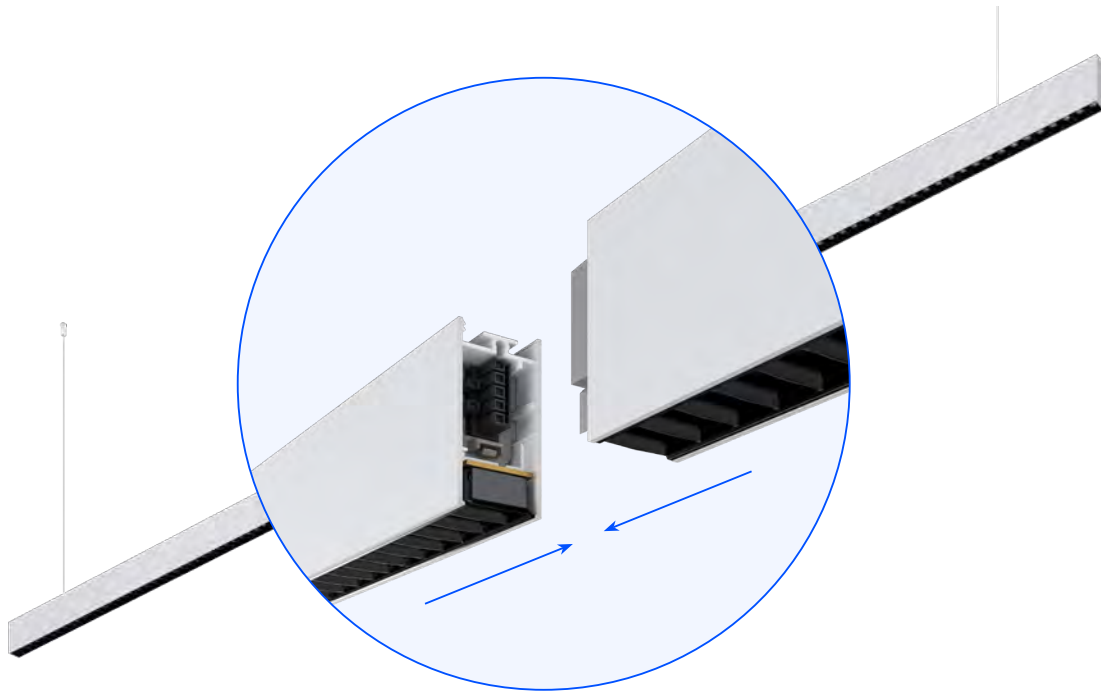

Mechanical and electrical connection Raccord mécanique et électrique

The design of the "Click & Go" mechanical and electrical connection makes it possible to create continuous lines that form a highly effective lighting layout, ensuring the continuity of the lighting delivered by the luminaires.

La conception du raccord mécanique et électrique "Click&Go" permet de créer des traits lumineux hautes performances, garantissant la continuité lumineuse et de service des luminaires.

Interchangeable louvres Grilles interchangeables

Black or matt silver

Noir ou argent mat

Choose between black or matt silver louvre depending on visual comfort or a larger light package but always maintaining the UGR<19. Choisissez entre une grille noire ou argentée mate en fonction du confort visuel ou un ensemble de lumières plus important, tout en conservant l'UGR<19.



Built-In driver

Great visual comfort with an extensive
lens of only 25 mm

Grand confort visuel avec une optique
extensive de seulement 25 mm

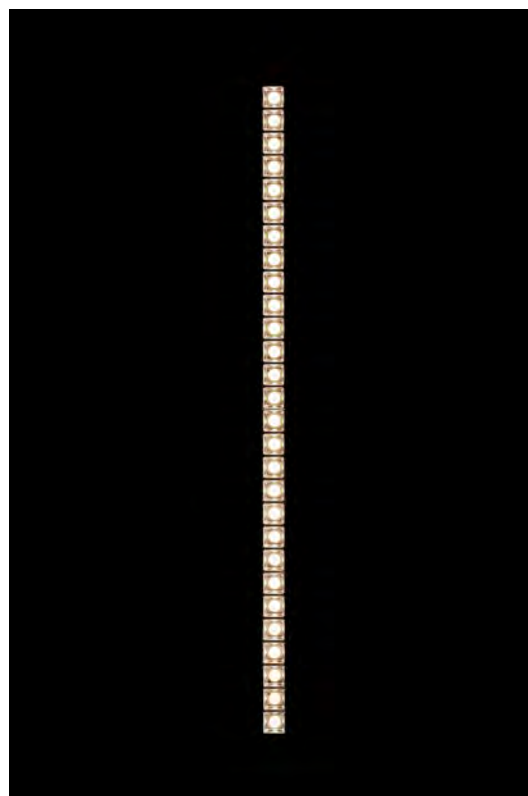
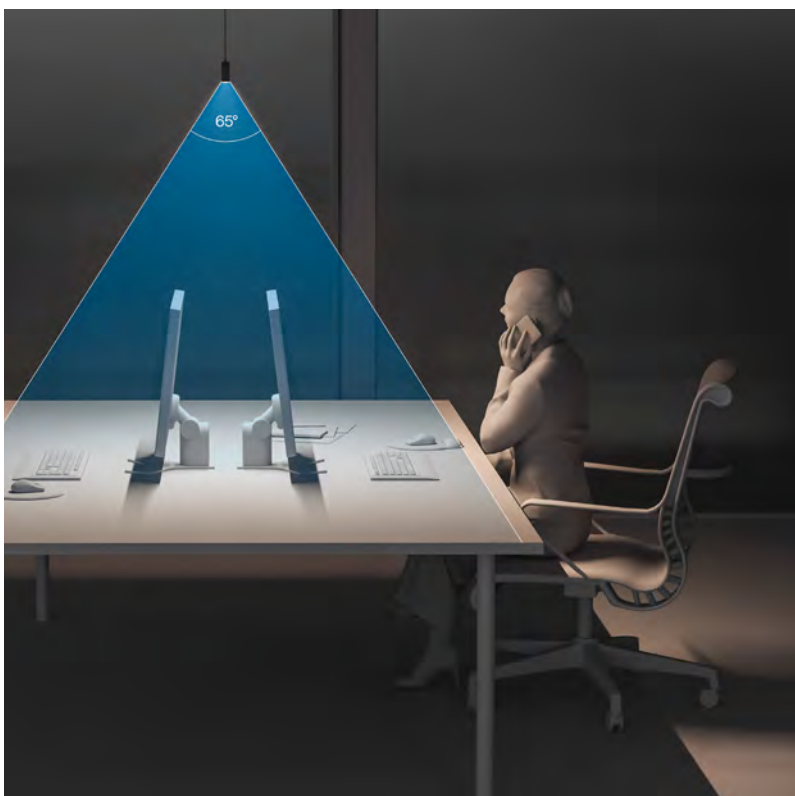





Infinite Slim Individual



Code example / Exemple d'élaboration d'une référence: **BB19-44W9GMOS14**

Model		W	K	CRI	Celosía	Real Lm	Source	Finishes	
560 mm BB36 - Recessed 	○ 14	15W9GM	15	3000	90	Matt Silver	1741	OS ON-OFF 220-240	14 ○
		15W9NM	15	3000	90	Matt Black	1475	DS DALI-2 220-240	60 ●
		15X9GM	15	4000	90	Matt Silver	1832		16 ●
		15X9NM	15	4000	90	Matt Black	1552		
1120 mm BB33 - Recessed 	○ 14	29W9GM	28.7	3000	90	Matt Silver	3481	OS ON-OFF 220-240	
		29W9NM	28.7	3000	90	Matt Black	2949	DS DALI-2 220-240	
		29X9GM	28.7	4000	90	Matt Silver	3664		
		29X9NM	28.7	4000	90	Matt Black	3104		
1680 mm BB19 - Surface BB21 - Pendant BB35 - Recessed 	○ ● ● 14 60 16	44W9GM	43.1	3000	90	Matt Silver	5221	OS ON-OFF 220-240	
		44X9NM	43.1	3000	90	Matt Black	4423	DS DALI-2 220-240	
		44X9GM	43.1	4000	90	Matt Silver	5496		
		44X9NM	43.1	4000	90	Matt Black	4656		

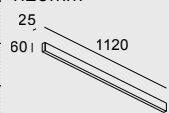
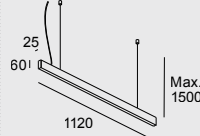
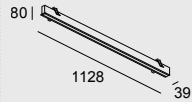
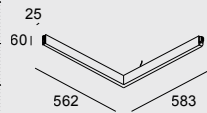
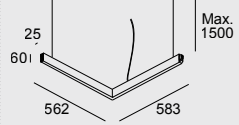
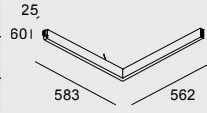
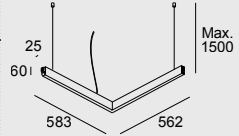

Code example / Exemple d'élaboration d'une référence: **BB11-29W9GM0S14**

Model	W	K	CRI	Celosía	Real Lm	Source	Finishes	
BB11 - Surface 1120mm 	29W9GM	28.7	3000	90	Matt Silver	3481	OS ON-OFF 220-240	14
	29W9NM	28.7	3000	90	Matt Black	2949	DS DALI-2 220-240	60
	29X9GM	28.7	4000	90	Matt Silver	3664		16
	29X9NM	28.7	4000	90	Matt Black	3104		
BB12 - Pendant 1120mm 	29W9GM	28.7	3000	90	Matt Silver	3481	OS ON-OFF 220-240	14
	29W9NM	28.7	3000	90	Matt Black	2949	DS DALI-2 220-240	60
BB31 - Recessed 1120mm 	29W9GM	28.7	3000	90	Matt Silver	3481	OS ON-OFF 220-240	14
	29W9NM	28.7	3000	90	Matt Black	2949	DS DALI-2 220-240	60
BB22 - Surface 	29W9GM	28.7	3000	90	Matt Silver	6962	OS ON-OFF 220-240	14
	29W9NM	28.7	3000	90	Matt Black	5898	DS DALI-2 220-240	60
	29X9GM	28.7	4000	90	Matt Silver	7328		16
	29X9NM	28.7	4000	90	Matt Black	6208		
BB23 - Pendant 	29W9GM	28.7	3000	90	Matt Silver	6962	OS ON-OFF 220-240	14
	29W9NM	28.7	3000	90	Matt Black	5898	DS DALI-2 220-240	60
BB26 - Surface 	29W9GM	28.7	3000	90	Matt Silver	6962	OS ON-OFF 220-240	14
	29W9NM	28.7	3000	90	Matt Black	5898	DS DALI-2 220-240	60
	29X9GM	28.7	4000	90	Matt Silver	7328		16
	29X9NM	28.7	4000	90	Matt Black	6208		
BB27 - Pendant 	29W9GM	28.7	3000	90	Matt Silver	6962	OS ON-OFF 220-240	14
	29W9NM	28.7	3000	90	Matt Black	5898	DS DALI-2 220-240	60

Fixing accessories
Accessoires de fixation



End cap (1u.)
Cache final (1 u.)

14 **71-B324-14-14**

60 **71-B324-60-60**

Infinite Slim
Continuity Lineal



Code example / Exemple d'élaboration d'une référence: **BB13-29W9GMOS14**

Model	W	K	CRI	Celosía	Real Lm	Source	Finishes	
BB13 - Surface 	29W9GM	28.7	3000	90	Matt Silver	3481	OS ON-OFF 220-240	14
	29W9NM	28.7	3000	90	Matt Black	2949	DS DALI-2 220-240	60
	29X9GM	28.7	4000	90	Matt Silver	3664		16
	29X9NM	28.7	4000	90	Matt Black	3104		
BB14 - Pendant 								
BB32 - Recessed 								
BB15 - Surface 	44W9GM	28.7	3000	90	Matt Silver	5221	OS ON-OFF 220-240	
	44W9NM	28.7	3000	90	Matt Black	4423	DS DALI-2 220-240	
	44X9GM	28.7	4000	90	Matt Silver	5496		
	44X9NM	28.7	4000	90	Matt Black	4656		
BB16 - Pendant 								
BB34 - Recessed 								
BB26 - Surface 	73W9GM	28.7	3000	90	Matt Silver	8702	OS ON-OFF 220-240	
	73W9NM	28.7	3000	90	Matt Black	7372	DS DALI-2 220-240	
	73X9GM	28.7	4000	90	Matt Silver	9160		
	73X9NM	28.7	4000	90	Matt Black	7760		
BB27 - Pendant 								

Infinite Slim Continuity Square



Code example / Exemple d'élaboration d'une référence: **BB24-29W9GM0S14**

Model		W	K	CRI	Celosía	Real Lm	Source	Finishes	
Right Square BB24 - Surface BB25 - Pendant 	<input type="radio"/> 14 <input checked="" type="radio"/> 60 <input type="radio"/> I6	29W9GM	28.7	3000	90	Matt Silver	6962	OS ON-OFF 220-240	14 <input type="radio"/>
		29W9NM	28.7	3000	90	Matt Black	5898	DS DALI-2 220-240	60 <input checked="" type="radio"/>
		29X9GM	28.7	4000	90	Matt Silver	7328		16 <input type="radio"/>
		29X9NM	28.7	4000	90	Matt Black	6208		
Left Square BB28 - Surface BB29 - Pendant 	<input type="radio"/> 14 <input checked="" type="radio"/> 60 <input type="radio"/> I6	29W9GM	28.7	3000	90	Matt Silver	6962	OS ON-OFF 220-240	
		29W9NM	28.7	3000	90	Matt Black	5898	DS DALI-2 220-240	
		29X9GM	28.7	4000	90	Matt Silver	7328		
		29X9NM	28.7	4000	90	Matt Black	6208		

INDOOR

LINEAL LIGHT SYSTEMS | SYSTÈMES D'ÉCLAIRAGE LINÉAIRES

Lineal

BODY MAT	DIF MAT
AL	PC



Lineal is a collection of profiles that adapt to all needs with different forms of installation to fit on surfaces of various kinds.

Lineal est une collection de profilés qui s'adaptent à tous les besoins avec différentes formes d'installation pour s'adapter à des surfaces de différents types.

Lineal Surfaced A

IP
20

○
54

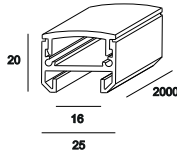

mm	Code	Optics
2000	71-3454 - 54 - M2 M3	Transparent Opal

Lineal Surfaced C

○
54

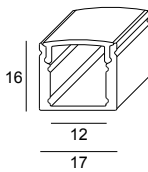

mm	Code	Optics
2000	71-A296 - 54 - M3	Opal

Lineal Square

○
54

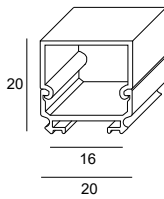

mm	Code	Optics
2000	71-8129 - 54 - M3	Opal

Lineal Flat Rectangular

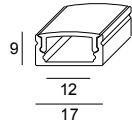

mm	Code	Optics
2000	71-8130 - 54 - M3	Opal

54

INDOOR

Lineal Square Tiny

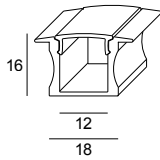

mm	Code	Optics
2000	71-8131 - 54 - M3	Opal

54



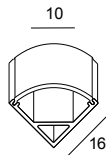



Lineal Surfaced Corner



mm	Code	Optics
2000	71-8132 - 54 - M3	Opal

54

LINEAL LIGHT SYSTEMS | SYSTÈMES D'ÉCLAIRAGE LINÉAIRES

	Lineal Surfaced A	Lineal Surfaced C	Lineal Square	Lineal Flat Rectangular	Lineal Square Tiny	Lineal Surfaced Corner
						

Fixing accessories Accessoires de fixation

3 fastening clips 3 fastening clips	Included	-	-	-	-	-
4 fastening clips 4 fastening clips	-	Included	Included	Included	Included	Included
2 end caps 2 end caps	Included	-	-	-	-	-
4 end caps 4 end caps	-	Included	Included	Included	Included	Included

Taglio di Luce

Designed by LedsC4 Architectural

A collection of profiles that opens the door to integrated lighting in walls and ceilings, enabling light to define the space through linear, wallwasher, contour or recessed lighting.

Collection de profilés qui ouvre la voie à un éclairage intégré sur murs et plafonds afin que la lumière définisse l'espace, que ce soit au moyen d'un éclairage linéaire, lèche-mur, de contour ou à effet corniche.





+ Taglio di Luce

INDOOR



LINEAL LIGHT SYSTEMS | SYSTÈMES D'ÉCLAIRAGE LINÉAIRES

Taglio di Luce Direct

Surface

Recessed

Pendant

Recessed Corner

19 mm

Trim

Trimless



35 mm

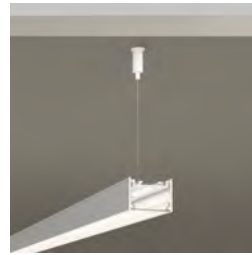
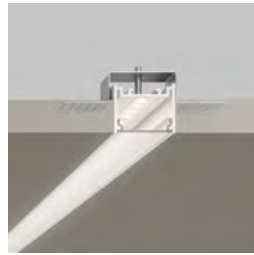
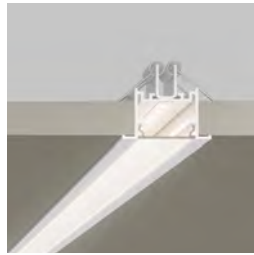

50 mm

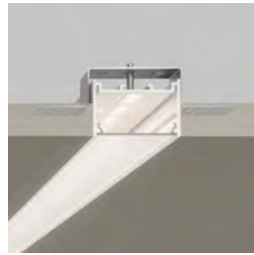
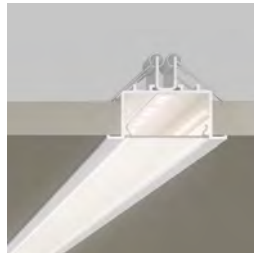

Taglio di Luce Indirect

Corner

Surface Doble

Surface Mono

Surface Recessed



Different sizes
Différentes tailles

- 1000 mm
- 2000 mm
- 3000 mm



Taglio di Luce Direct surface. Integration in the architecture to emphasise the space with a playful linear light effect. Manusa project.
Taglio di Luce Direct de surface. Intégration dans l'architecture pour mettre l'espace en valeur dans un jeu de lumière linéaire. Projet Manusa.



Residential project in Barcelona. Interior design: Miriam Barrios. Photography: Salva López.
Projet résidentiel à Barcelone. Design d'intérieur: Miriam Barrios. Photographie : Salva López.

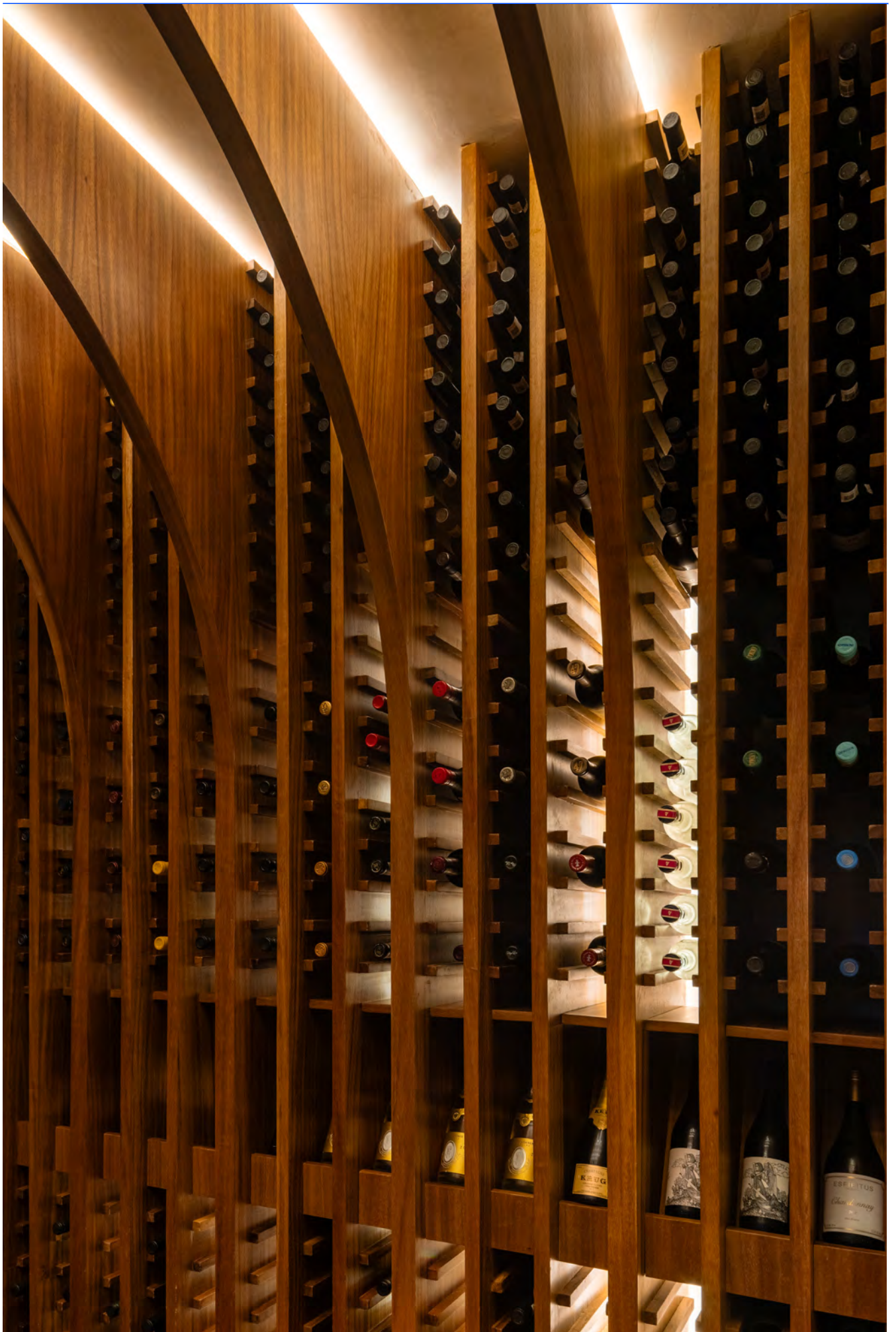

Winery at Hotel Rivera Maya, Mexico. Lighting Designer: Trazo. Photography: Gabriela Sarahi.
Cellier de l'hôtel Rivera Maya, Mexique. Concepteur lumière : Trazo. Photographie : Gabriela Sarahi.









Taglio di Luce structures can be combined with LED strips from the ON collection to offer multiple options, such as RGB.
Les structures Taglio di Luce peuvent être combinées avec des rubans LED de la collection ON qui offre de multiples options, comme le RGB.
See ON collection / Voir la collection ON

Taglio Direct

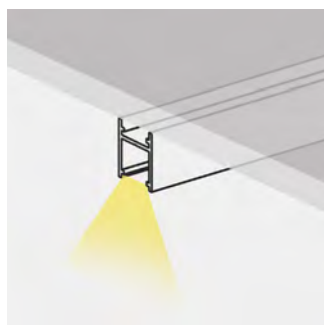

Direct Surface

Ideal for wooden structures and concrete ceilings where recessing proves challenging.

Idéal pour les structures en bois et les plafonds en béton présentant des difficultés d'encastrement

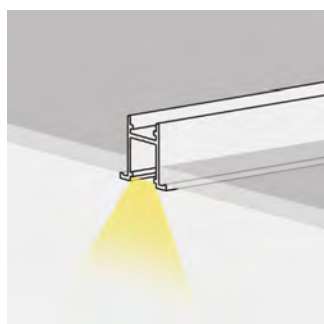

Direct Recessed Trim

Easy installation thanks to the design of the ribs, which make it possible to overcome minor irregularities.

Installation facile grâce à la conception des ailettes, qui permettent de combler les petites irrégularités.

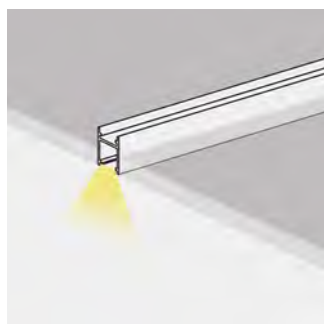

Direct Recessed Trimless

Full integration into the space, where the only protagonist is the light.

Intégration totale dans l'espace, qui fait la part belle à la lumière

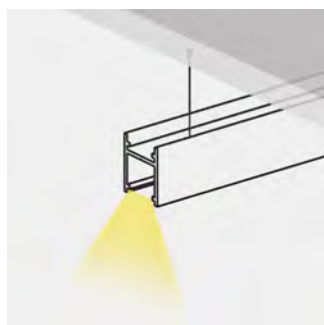

Direct Pendant

Pendant option with the possibility of interlinking using the optional accessory kit.

Option suspendue avec possibilité d'installation en chaîne, grâce à l'application kit d'accessoire en option.

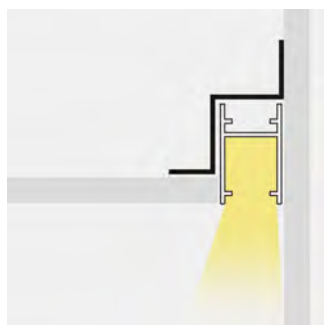

Direct Recessed Corner

Trimless contour profiling with a direct visible line effect.

Profilé de contours trimless avec effet ligne visible direct.

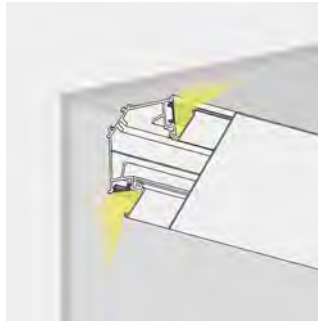

Indirect Corner

Contour profile for wall or ceiling with double light output to enhance the perimeter and add volume to the room.
Profilé de contour mural ou de plafond avec double sortie d'éclairage pour rehausser le périmètre et donner du volume à la pièce.

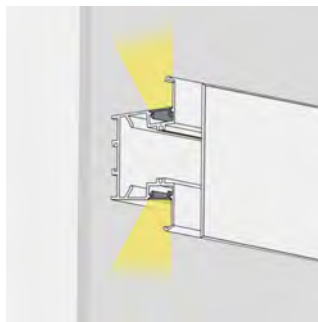

Indirect Surface Double

Wall-mounted Up & Down option.
Option murale Up & Down.

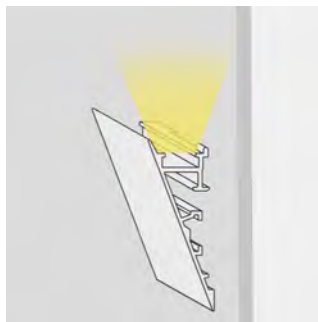

Indirect Surface Mono

Maximum integration, since its profile can be painted with the final finish of the installation.
Intégration maximale, car son profilé peut être peint dans le coloris définitif de l'installation.



Indirect Surface Recessed

The luminaire is completely hidden and built into the ceiling. Ideal for pitted perimeters.
Le luminaire est ainsi totalement dissimulé et intégré au plafond. Idéal pour les périmètres à corniche.

Taglio di Luce

Direct

BODY MAT
AL

Taglio di Luce Direct 19 mm Trim Recessed

○
14

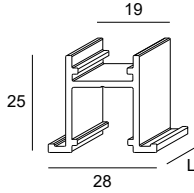

mm	Code
1000	71-5738
2000	71-5739 - 14 - 00
3000	71-5740

20xL 0-20 mm

Taglio di Luce Direct 19 mm Trimless Recessed

○
14

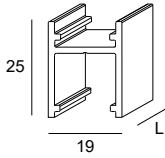

mm	Code
1000	71-5741
2000	71-5742 - 14 - 00
3000	71-5743

19xL 0-15 mm

Taglio di Luce Direct 19 mm Trimless Surface

○
14

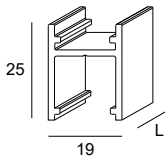

mm	Code
1000	71-5741
2000	71-5742 - 14 - 00
3000	71-5743

Taglio di Luce Direct 35 mm Trim Recessed

○
14

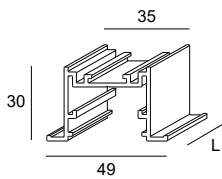

mm	Code
1000	71-5744
2000	71-5745 - 14 - 00
3000	71-5746

40xL 0-25 mm

**Taglio di Luce Direct 35 mm
Trimless Recessed**

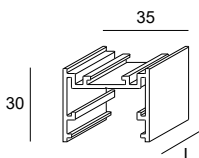

mm
1000
2000
3000

Code
71-5747
71-5748 - 14 - 00
71-5749

35xL 0-20 mm

14

INDOOR

**Taglio di Luce Direct 35 mm
Trimless Surface**

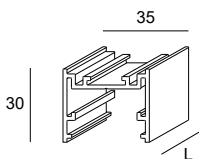

mm
1000
2000
3000

Code
71-5747
71-5748 - 14 - 00
71-5749

14

**Taglio di Luce Direct 50 mm
Trim Recessed**

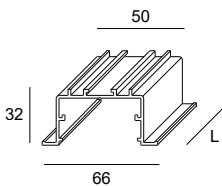

mm
1000
2000
3000

Code
71-8082
71-8083 - 14 - 00
71-8084

55 0-25 mm

14

LINEAL LIGHT SYSTEMS | SYSTÈMES D'ÉCLAIRAGE LINÉAIRES

**Taglio di Luce Direct 50 mm
Trimless Recessed**

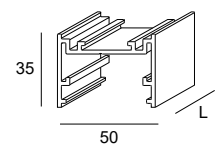

mm
1000
2000
3000

Code
71-5753
71-5754 - 14 - 00
71-5755

50xL 0-25 mm

14

**Taglio di Luce Direct 50 mm
Trimless Surface**

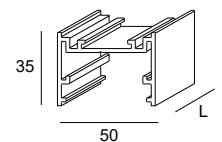

mm
1000
2000
3000





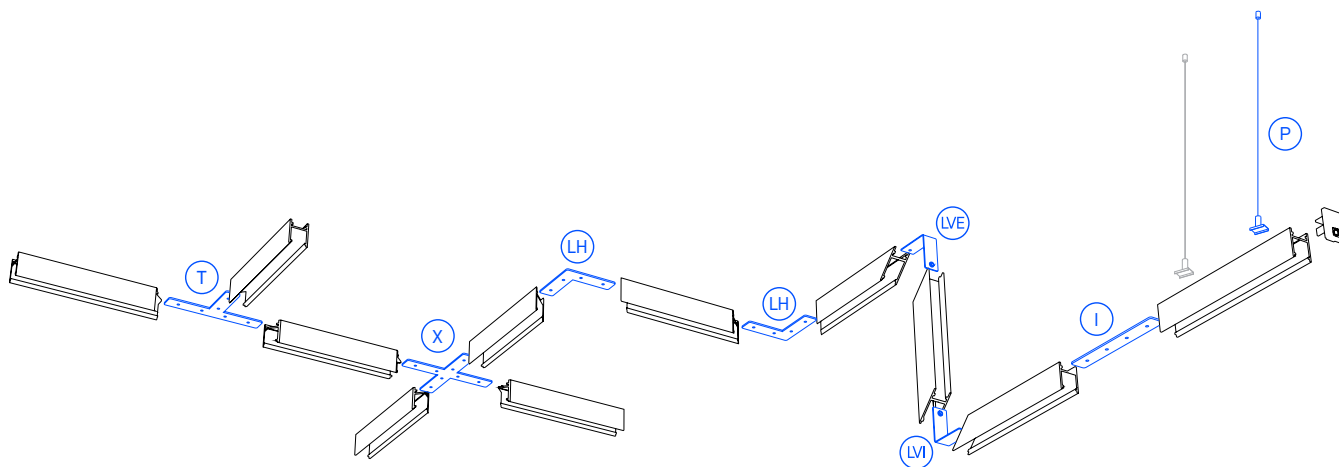

Code
71-5753
71-5754 - 14 - 00
71-5755

14





Installation diagram / Schéma d'installation



Joint accessories / Accessoires de raccord

						
T	X	LH	LVE	LVI	I	P
"T" union kit Kit de raccord en « T »	"X" union kit Kit de raccord en « X »	"LH" union kit Kit de raccord en « LH »	"LVE" union kit Kit de raccord « LVE »	"LVI" union kit Kit de raccord « LVI »	"I" union kit Kit de raccord en « I »	Suspended installation kit Kit d'installation suspendue
71-5784-00-00	71-5785-00-00	71-5783-00-00	71-5757-00-00	71-5758-00-00	71-5782-00-00	71-B249-14-00 71-B249-60-00

Taglio Di Luce Direct
19 mm TrimlessTaglio Di Luce Direct
35 mm TrimlessTaglio Di Luce Direct
50 mm Trimless**Required lens accessories****Accessoires optiques nécessaires**

	1000mm diffuser Diffuseur 1 000 mm	71-5771-00-00	71-5775-00-00	71-5779-00-00
	2000mm diffuser Diffuseur 2 000 mm	71-5772-00-00	71-5776-00-00	71-5780-00-00
	3000mm diffuser Diffuseur 3 000 mm	71-5773-00-00	71-5777-00-00	71-5781-00-00
	10000mm diffuser Diffuseur 10 000 mm	71-5774-00-00	71-5778-00-00	71-5486-00-00

Fastening accessories for trimless recessed track**Accessoires de fixation pour rail encastré trimless**

	Recessed Kit 1000mm trimless	71-5786-00-00	71-5787-00-00	71-5788-00-00
-----------------------------------------------------------------------------------	------------------------------	----------------------	----------------------	----------------------



Decorative accessories**Accessoires décoratifs**

	End cap (2u.) Cache final (2 u.)	71-5766-14-00	71-5768-14-00	71-5770-14-00
-----------------------------------------------------------------------------------	-------------------------------------	----------------------	----------------------	----------------------







Fastening accessories for corner trimless recessed track**Accessoires de fixation pour rail encastré d'angle trimless**

	Recessed corner Encastré d'angle	71-B482-14-00	-	-
-------------------------------------------------------------------------------------	-------------------------------------	----------------------	---	---





Fixing accessories for pendant track**Accessoires de fixation pour rail suspendu**

	Suspended installation kit Kit d'installation suspendue		14 ○	71-B249-14-00	71-B249-14-00	71-B249-14-00
			60 ●	71-B249-60-00	71-B249-60-00	71-B249-60-00
	Remote installation ceiling rose 24V Floron pour installation à distance 24V	60W	14 ○	71-B252-14-00	71-B252-14-00	71-B252-14-00
			60 ●	71-B252-60-00	71-B252-60-00	71-B252-60-00
		150W	14 ○	71-B253-14-00	71-B253-14-00	71-B253-14-00
			60 ●	71-B253-60-00	71-B253-60-00	71-B253-60-00

Joint accessories**Accessoires de raccord**

	"I" union kit Kit de raccord en « I »	71-5782-00-00	71-5782-00-00	71-5782-00-00
	"T" union kit Kit de raccord en « T »	71-5784-00-00	71-5784-00-00	71-5784-00-00
	"X" union kit Kit de raccord en « X »	71-5785-00-00	71-5785-00-00	71-5785-00-00
	"LH" union kit Kit de raccord en « LH »	71-5783-00-00	71-5783-00-00	71-5783-00-00
	"LVE" union kit Kit de raccord « LVE »	71-5757-00-00	71-5757-00-00	71-5757-00-00
	"LVI" union kit Kit de raccord « LVI »	71-5758-00-00	71-5758-00-00	71-5758-00-00

Taglio di Luce Direct
19 mm TrimTaglio di Luce Direct
35 mm TrimTaglio di Luce Direct
50 mm Trim**Required lens accessories****Accessoires optiques nécessaires**

	1000mm diffuser Diffuseur 1 000 mm	71-5771-00-00	71-5775-00-00	71-5779-00-00
	2000mm diffuser Diffuseur 2 000 mm	71-5772-00-00	71-5776-00-00	71-5780-00-00
	3000mm diffuser Diffuseur 3 000 mm	71-5773-00-00	71-5777-00-00	71-5781-00-00
	10000mm diffuser Diffuseur 10 000 mm	71-5774-00-00	71-5778-00-00	71-5486-00-00







Required fixing accessories**Accessoires de fixation nécessaires**

	1000mm installation kit Kit d'installation 1 000 mm	71-5511-00-00	71-5511-00-00	71-5511-00-00
-----------------------------------------------------------------------------------	--------------------------------------------------------	---------------	---------------	---------------

Decorative accessories**Accessoires décoratifs**

	End cap (2u.) Cache final (2 u.)	71-5765-14-00	71-5767-14-00	71-7640-14-00
------------------------------------------------------------------------------------	-------------------------------------	---------------	---------------	---------------

Joint accessories**Accessoires de raccord**

	"I" union kit Kit de raccord en « I »	71-5782-00-00	71-5782-00-00	71-5782-00-00
	"T" union kit Kit de raccord en « T »	71-5784-00-00	71-5784-00-00	71-5784-00-00
	"X" union kit Kit de raccord en « X »	71-5785-00-00	71-5785-00-00	71-5785-00-00
	"LH" union kit Kit de raccord en « LH »	71-5783-00-00	71-5783-00-00	71-5783-00-00
	"LVE" union kit Kit de raccord « LVE »	71-5757-00-00	71-5757-00-00	71-5757-00-00
	"LVI" union kit Kit de raccord « LVI »	71-5758-00-00	71-5758-00-00	71-5758-00-00

Taglio di Luce Indirect Surface

14

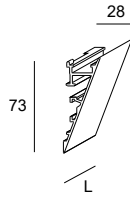
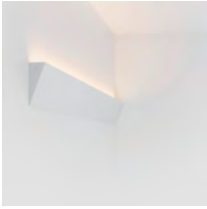

mm

1000
2000
3000

Code

71-5759
71-5760 - 14 - 00
71-5761

Taglio di Luce Indirect Recessed

14

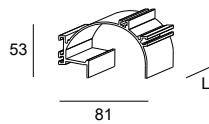

mm

1000
2000
3000

Code

71-5762
71-5763 - 14 - 00
71-5764

55xL 0-12 mm

Taglio di Luce Indirect Double Corner

14

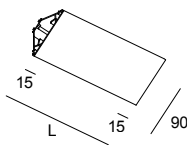

mm

1000
2000
3000

Code

71-B706
71-B707 - 14 - 00
71-B708

55xL 0-12 mm

Taglio di Luce Indirect Double Flat

14

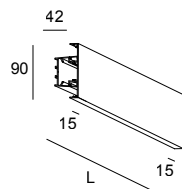
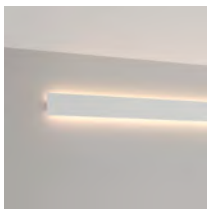

mm

1000
2000
3000

Code

71-B702
71-B703 - 14 - 00
71-B704

Installation diagram / Schéma d'installation

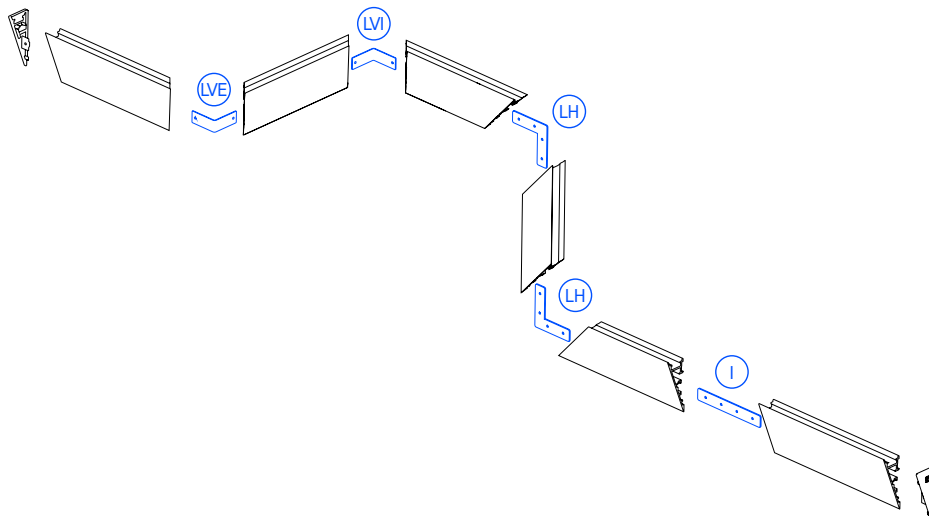

Installation diagram / Schéma d'installation

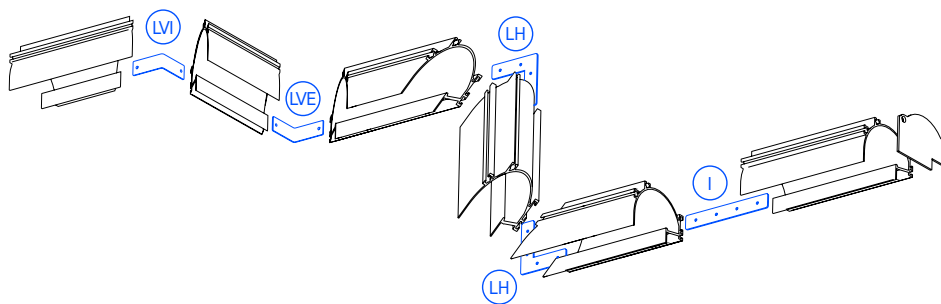

Joint accessories / Accessoires de raccord



LVI
 "LVI" union kit
 Kit de raccord « LVI »

71-5758-00-00



LVE
 "LVE" union kit
 Kit de raccord « LVE »

71-5757-00-00







LH
 "LH" union kit
 Kit de raccord en « LH »

71-5783-00-00



I
 "I" union kit
 Kit de raccord en « I »



71-5782-00-00

	Taglio di Luce Indirect Double Corner	Taglio di Luce Indirect Double Flat	Taglio di Luce Indirect Surface	Taglio di Luce Indirect Recessed
				

Lens accessories Accessoires optiques

	1000mm diffuser Diffuseur 1 000 mm	Included	Included	71-5771-00-00	-
	2000mm diffuser Diffuseur 2 000 mm	Included	Included	71-5772-00-00	-
	3000mm diffuser Diffuseur 3 000 mm	Included	Included	71-5773-00-00	-
	10000mm diffuser Diffuseur 10 000 mm	Included	Included	71-5774-00-00	-



Required fixing accessories Accessoires de fixation nécessaires

	1000mm installation kit Kit d'installation 1 000 mm	-	-	-	71-5789-00-00
	Profile installation kit Kit de fixation de profilé	-	-	71-5756-14-00	-

Decorative accessories Accessoires décoratifs

	End cap (2u.) Cache final (2 u.)	71-B709-14-00	71-B705-14-00	71-5608-14-00	71-5609-14-00
-------------------------------------------------------------------------------------	-------------------------------------	---------------	---------------	---------------	---------------

Joint accessories Accessoires de raccord

	"I" union kit Kit de raccord en « I »	71-B710-00-00	71-B710-00-00	71-5782-00-00	71-5782-00-00
	"LH" union kit Kit de raccord en « LH »	71-5783-00-00	71-5783-00-00	71-5783-00-00	71-5783-00-00
	"LVE" union kit Kit de raccord « LVE »	-	-	71-5757-00-00	71-5757-00-00
	"LVI" union kit Kit de raccord « LVI »	-	-	71-5758-00-00	71-5758-00-00

Signalling Signalisation

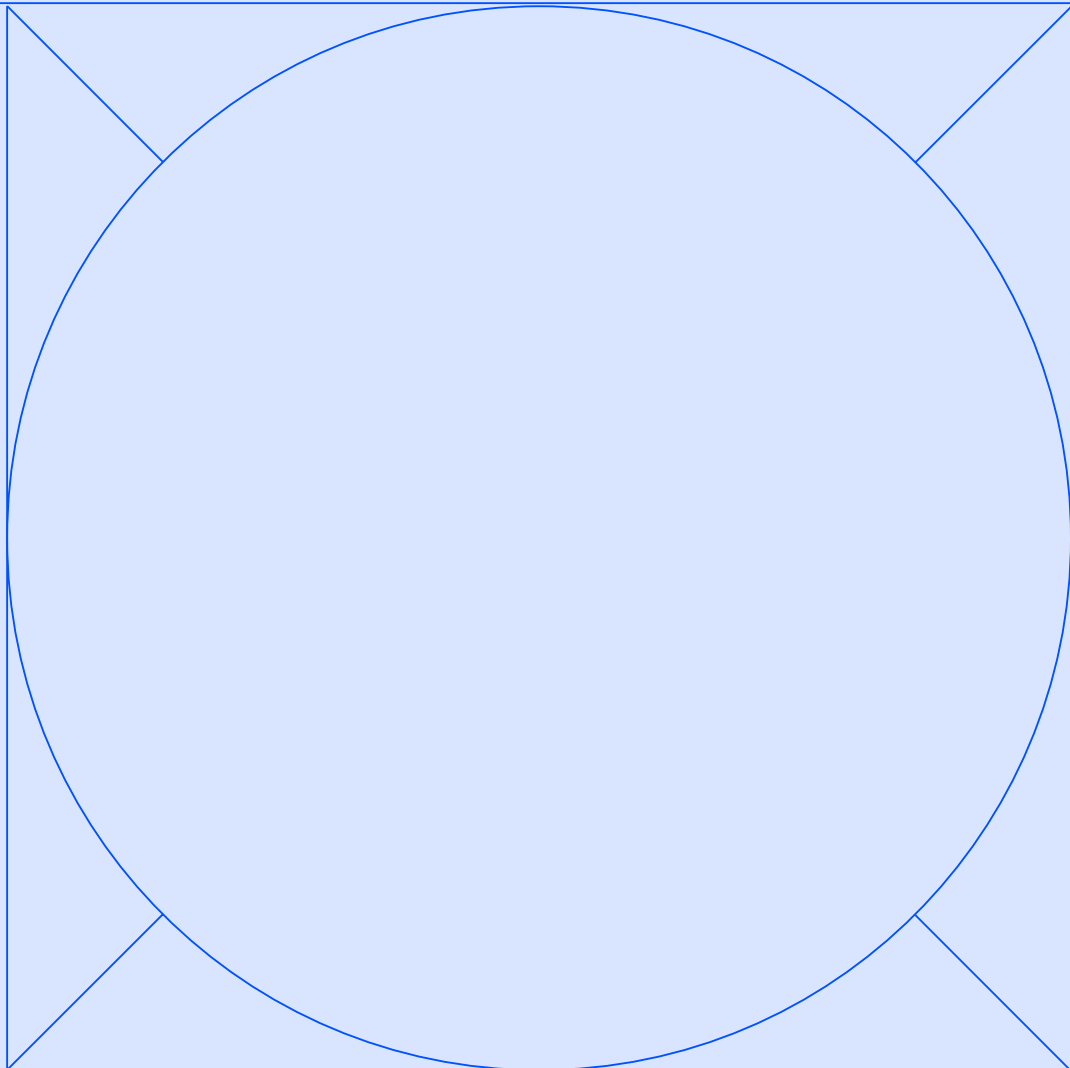

Click
400

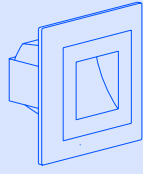

Bat
403

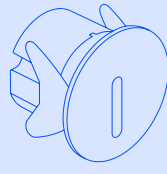

Secret
409

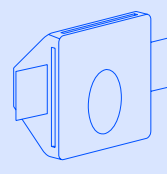

Step
410

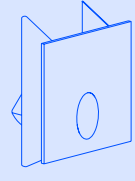

Click

Designed by LedsC4 Architectural



+ Click



Clean, compact design Design épuré et compact

The Click collection is highly practical as it has been designed so that its installation is compatible with universal mechanism boxes. The driver is included inside the luminaire, making installation even more straightforward. La collection Click est très pratique, car elle a été conçue pour être compatible avec les boîtiers d'encastrement universels. Le driver est inclus à l'intérieur du luminaire, ce qui rend l'installation encore plus facile.

Perfect for both indoor and outdoor installations.
Parfait tant pour les installations en extérieur qu'en intérieur.





Installation in universal mechanism boxes

Installation dans des boîtiers d'encastement universels

Compatible with all universal mechanism boxes: square and round, outdoor and indoor, construction and plasterboard.
 Compatible avec tous les boîtiers d'encastement universels: carrés et ronds, d'extérieur et d'intérieur, maçonneries ou en placo-plâtre.

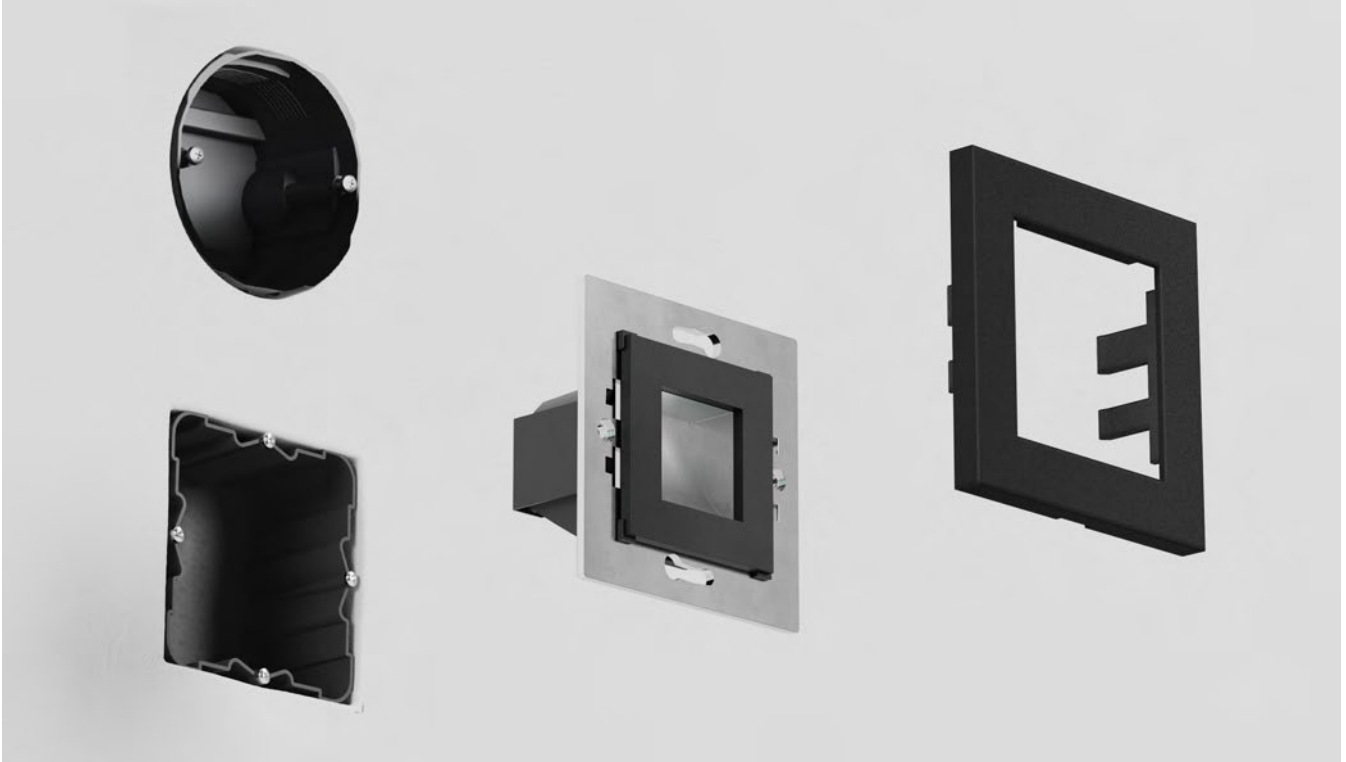

Click

BODY MAT	DIF MAT		IP	IK	SEA SIDE
PC	GLA		65	07	SUITABLE

●
05

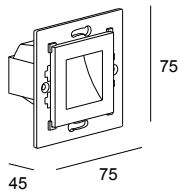

LED						
K	CRI	W Total	Real Lm	Code		
2700	80	1.4	31	05-E141	- 05 -	CK ON-OFF 220-240V
3000	80	1.4	31	05-E141		CL ON-OFF 220-240V

Decorative accessories

Accessoires décoratifs



Frame
Pièce frontale

Z5 ● **71-E489-Z5-Z5**

14 ○ **71-E489-14-14**

60 ● **71-E489-60-60**

34 ○ **71-E489-34-34**

J6 ● **71-E489-J6-J6**

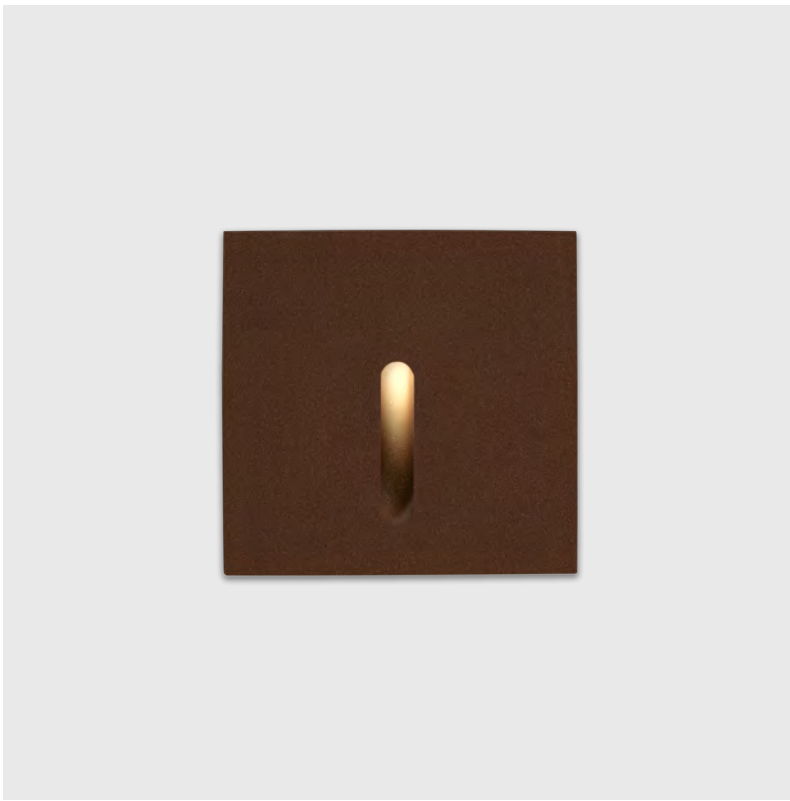

The elasticity of light in the smallest space L'élasticité de la lumière dans un minimum d'espace

Bat is a signage light that has been meticulously designed down to every last detail, from the sculpting of the light it emits to its structure featuring a textured body in different finishes.

Bat est un modèle de signalisation soigné dans les détails, tant dans le façonnage de la lumière qu'elle émet que dans sa structure, avec un corps texturé en différentes finitions.

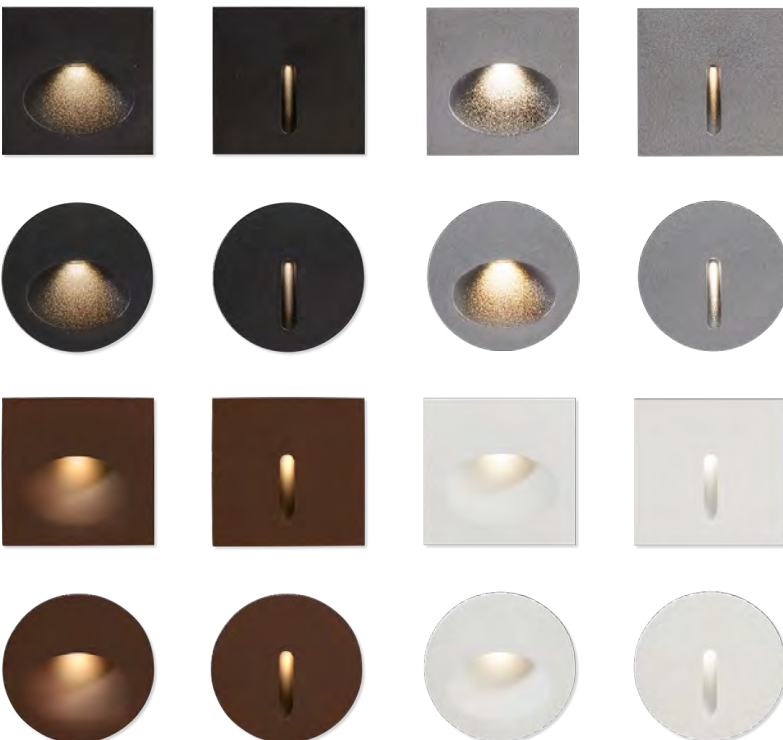

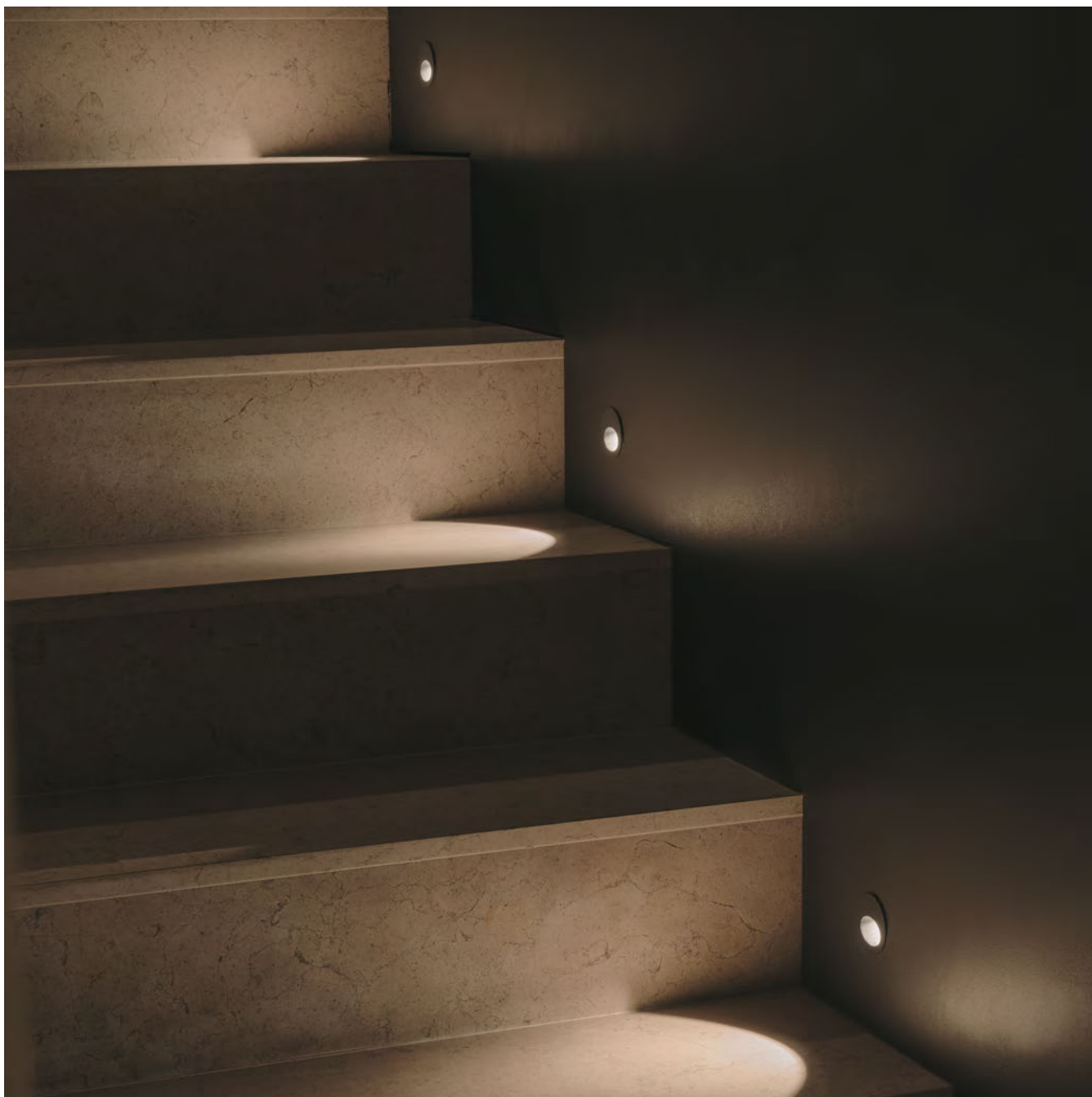

Different effects for adjusting to
diverse signage needs.
Différents effets pour répondre
aux besoins de signalisation.

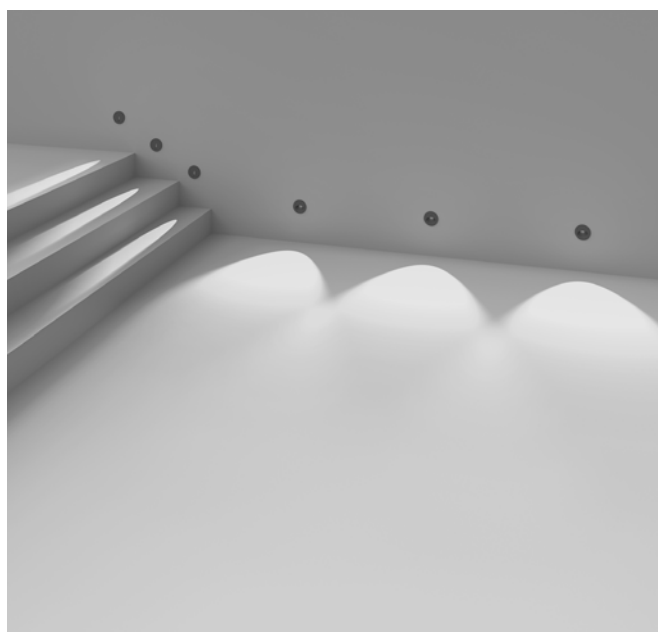

Sunken LED for maximum comfort.
LED renforcée pour un maximum de confort.



Ribs for installation in plasterboard and special anti-open cable gland to ensure watertightness in outdoor settings.
Ailettes pour installation sur placoplâtre et presse-étoupe spécial anti-ouverture qui garantit son étanchéité dans les espaces extérieurs.



Built-in driver
Driver intégré



Remote driver
Driver distant

Bat Square Lineal

BODY MAT	DIF MAT	3		50000h	IP	IK		SEA SIDE SUITABLE
AL	GLA	MacAdam		L80 B20	66	10	1 m	

Z5 34 J6 14

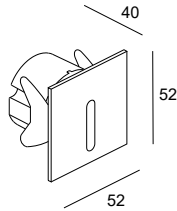
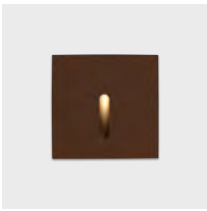

43

LED							max.700mA 3V	
K	CRI	W	Real Lm	Optics	Code	Z5	34	J6
2700	90	2.2	10	23°	05-E017	-	CK	14
3000	90	2.2	10	23°	05-E017	-	CL	14
4000	90	2.2	10	23°	05-E017	-	CM	14

Bat Square Lineal Driver

BODY MAT	DIF MAT	3		50000h	IP	IK		SEA SIDE SUITABLE
AL	GLA	MacAdam		L80 B20	66	10	1 m	

Z5 34 J6 14

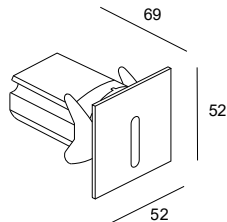
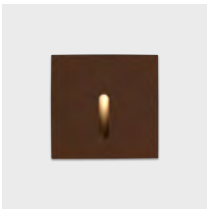

43

LED								
K	CRI	W Total	Real Lm	Optics	Code	Z5	34	J6
2700	90	3	10	23°	05-E112	-	CK	ON-OFF 220-240V
3000	90	3	10	23°	05-E112	-	CL	ON-OFF 220-240V
4000	90	3	10	23°	05-E112	-	CM	ON-OFF 220-240V

Bat Square Oval

BODY MAT	DIF MAT	3		50000h	IP	IK		SEA SIDE SUITABLE
AL	GLA	MacAdam		L80 B20	66	10	1 m	

Z5 34 J6 14

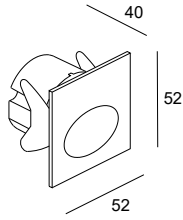
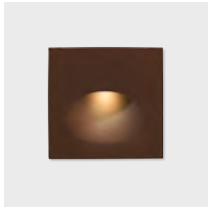

43

LED							max.700mA 3V	
K	CRI	W	Real Lm	Optics	Code	Z5	34	J6
2700	90	2.2	77	60°	05-E016 -	14	-	CK
3000	90	2.2	77	60°	05-E016 -	14	-	CL
4000	90	2.2	77	60°	05-E016 -	14	-	CM

Bat Square Oval Driver

BODY MAT	DIF MAT	3		50000h	IP	IK		SEA SIDE SUITABLE
AL	GLA	MacAdam		L80 B20	66	10	1 m	

Z5 34 J6 14

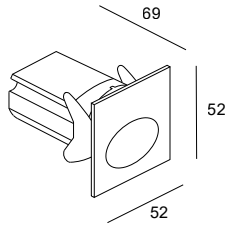
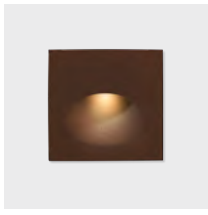

43

LED									
K	CRI	W Total	Real Lm	Optics	Code	Z5	34	J6	
2700	90	3	77	60°	05-E111 -	14	-	CK ON-OFF 220-240V	
3000	90	3	77	60°	05-E111 -	14	-	CL ON-OFF 220-240V	
4000	90	3	77	60°	05-E111 -	14	-	CM ON-OFF 220-240V	

Bat Round Lineal

BODY MAT	DIF MAT	3		50000h	IP	IK		SEA SIDE SUITABLE
AL	GLA	MacAdam		L80 B20	66	10	1 m	

Z5 34 J6 14

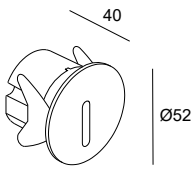
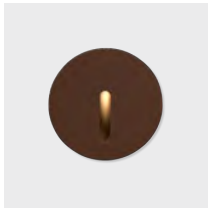

43

LED							max.700mA 3V	
K	CRI	W	Real Lm	Optics	Code	Z5	34	J6
2700	90	2.2	10	23°	05-E015 -	14	-	CK
3000	90	2.2	10	23°	05-E015 -	14	-	CL
4000	90	2.2	10	23°	05-E015 -	14	-	CM

Bat Round Lineal Driver

BODY MAT	DIF MAT	3		50000h	IP	IK		SEA SIDE
AL	GLA	MacAdam		L80 B20	66	10	1 m	SUITABLE

Z5 34 J6 14

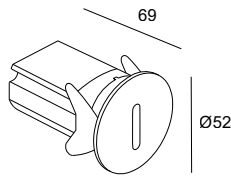
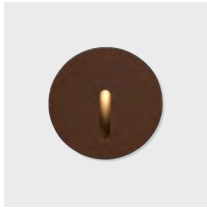

43

LED							
K	CRI	W Total	Real Lm	Optics	Code		
2700	90	3	10	23°	05-E110 -	Z5 34 J6 14	- CK ON-OFF 220-240V
3000	90	3	10	23°	05-E110 -	Z5 34 J6 14	- CL ON-OFF 220-240V
4000	90	3	10	23°	05-E110 -	Z5 34 J6 14	- CM ON-OFF 220-240V

Bat Round Oval

BODY MAT	DIF MAT	3		50000h	IP	IK		SEA SIDE
AL	GLA	MacAdam		L80 B20	66	10	1 m	SUITABLE

Z5 34 J6 14

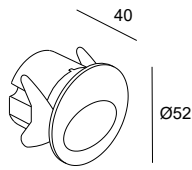
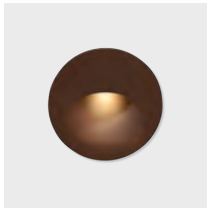

43

LED							max.700mA 3V	
K	CRI	W	Real Lm	Optics	Code			
2700	90	2.2	77	60°	05-E014 -	Z5 34 J6 14	- CK	
3000	90	2.2	77	60°	05-E014 -	Z5 34 J6 14	- CL	
4000	90	2.2	77	60°	05-E014 -	Z5 34 J6 14	- CM	

Bat Round Oval Driver

BODY MAT	DIF MAT	3		50000h	IP	IK		SEA SIDE
AL	GLA	MacAdam		L80 B20	66	10	1 m	SUITABLE

Z5 34 J6 14

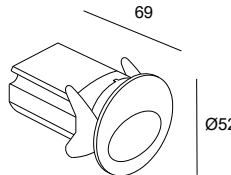
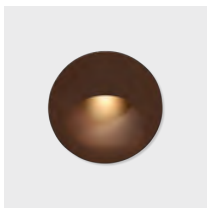

43

LED							
K	CRI	W Total	Real Lm	Optics	Code		
2700	90	3	77	60°	05-E108 -	Z5 34 J6 14	- CK ON-OFF 220-240V
3000	90	3	77	60°	05-E108 -	Z5 34 J6 14	- CL ON-OFF 220-240V
4000	90	3	77	60°	05-E108 -	Z5 34 J6 14	- CM ON-OFF 220-240V



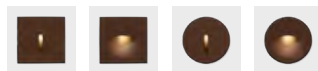

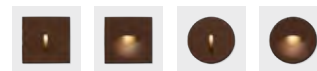

Bat Square & Round



Bat Square & Round Driver



Drivers
Drivers

P. 984

	ON-OFF IP20 * For incorporation into a recessing case * À intégrer dans le boîtier d'encastrement	71-B781-00-00	-
		71-6658-00-00 	-
		Min.4 - Max.9	
	PHASE CUT 240V IP20	71-4898-00-00 	-
		Min.1 - Max.14	
	DALI2 IP20	71-A192-00-00 	-
		Min.4 - Max.13	

Fixing accessories

Accessoires de fixation

	Recessing case for masonry walls Boîtier d'encastrement pour mur en maçonnerie	71-E404-00-00	71-E404-00-00
	Recessing case for masonry/concrete walls to incorporate the 71-B781 driver. Boîtier d'encastrement pour mur en maçonnerie/béton permettant d'intégrer le driver 71-B781.	71-E065-60-00	71-E065-60-00

Connection accessories

Accessoires de connexion

	IP67 connector (1 input + 1 output) Ø 5.5–7.5 mm, 3 poles Connecteur IP67 (1 entrée + 1 sortie) Ø 5,5 - 7,5 mm, 3 pôles	71-E510-00-00	71-E510-00-00
	IP67 connector (1 input + 2 outputs) Ø 5.5–7.5 mm, 3 poles Connecteur IP67 (1 entrée + 2 sorties) Ø 5,5 - 7,5 mm, 3 pôles	-	71-E511-00-00
	IP68 connector (1 input + 1 output) Ø 5.5–11.5 mm, 4 poles Connecteur IP68 (1 entrée + 1 sortie) Ø 5,5 - 11,5 mm, 4 pôles	71-E512-00-00	71-E512-00-00
	IP68 connector (1 input + 2 outputs) Ø 5.5–11.5 mm, 3 poles Connecteur IP68 (1 entrée + 2 sorties) Ø 5,5 - 11,5 mm, 3 pôles	-	71-E513-00-00
	IP68 anti-condensation connector (1 input + 1 output) Ø 5.5–12 mm, 4 poles Connecteur anticondensation IP68 (1 entrée + 1 sortie) Ø 5,5 - 12 mm, 4 pôles	71-E112-00-00	71-E112-00-00
	IP68 anti-condensation connector (1 input + 3 outputs) Ø 5.5–12 mm, 4 poles Connecteur anticondensation IP68 (1 entrée + 3 sorties) Ø 5,5 - 12 mm, 4 pôles	-	71-E122-00-00
	IP67 connection box (1 input + 2 outputs) Ø 6–7.5 mm, 3 poles Boîtier de raccordement IP67 (1 entrée + 2 sorties) Ø 6 - 7,5 mm, 3 pôles	71-9262-05-05	-
	IP68 connection box (1 input + 5 outputs) Ø 6.5–11 mm, 6 poles Boîtier de raccordement IP67 (1 entrée + 5 sorties) Ø 6,5 - 11 mm, 6 pôles	71-9199-05-05	71-9199-05-05

Secret A

BODY MAT PLSTER	DIF MAT PC		50000h L80 B20	3 MacAdam	IP 20	
--------------------	---------------	--	-------------------	--------------	----------	--

14

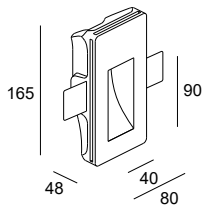

LED					max.350mA 3V
K	CRI	W	Real Lm	Code	
3000	80	1	69	05-1804 - 14 - 00	

170x85 9-15

Secret B

BODY MAT PLSTER	DIF MAT PC		50000h L80 B20	3 MacAdam	IP 20	
--------------------	---------------	--	-------------------	--------------	----------	--

14

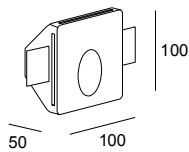

LED					max.350mA 3V
K	CRI	W	Real Lm	Code	
3000	80	1	93	05-2904 - 14 - 00	

105x105 9-16

Drivers

P. 984



ON-OFF
IP20

71-B681-00-00
Min.1 - Max.3

71-3542-00-00
Min.1 - Max.25



PHASE CUT
240V
IP20

71-4898-00-00
Min.1 - Max.16



DALI2
IP20

71-4706-00-00
Min.1 - Max.25

71-A191-00-00
Min.9 - Max.16

Step

Step Round

BODY MAT		50000h	3	IP	
AL		L80 B20	MacAdam	20	

○
14

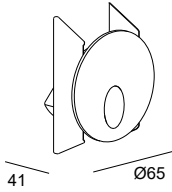
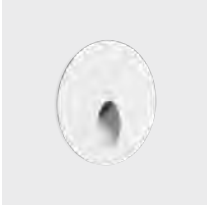

LED						
K	CRI	W Total	Real Lm	Code		
3000	80	4	194	55-1573 - 14 - 00	ON-OFF	220-240V

57

Step Square

IP	
20	

○
14

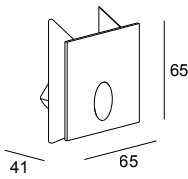

LED						
K	CRI	W Total	Real Lm	Code		
3000	80	4	194	55-1574 - 14 - 00	ON-OFF	220-240V

57

Fixing accessories Accessoires de fixation



Recess case
Boîtier d'encastrement

Included

Included

Asai

412

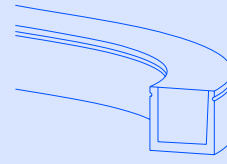

On

420

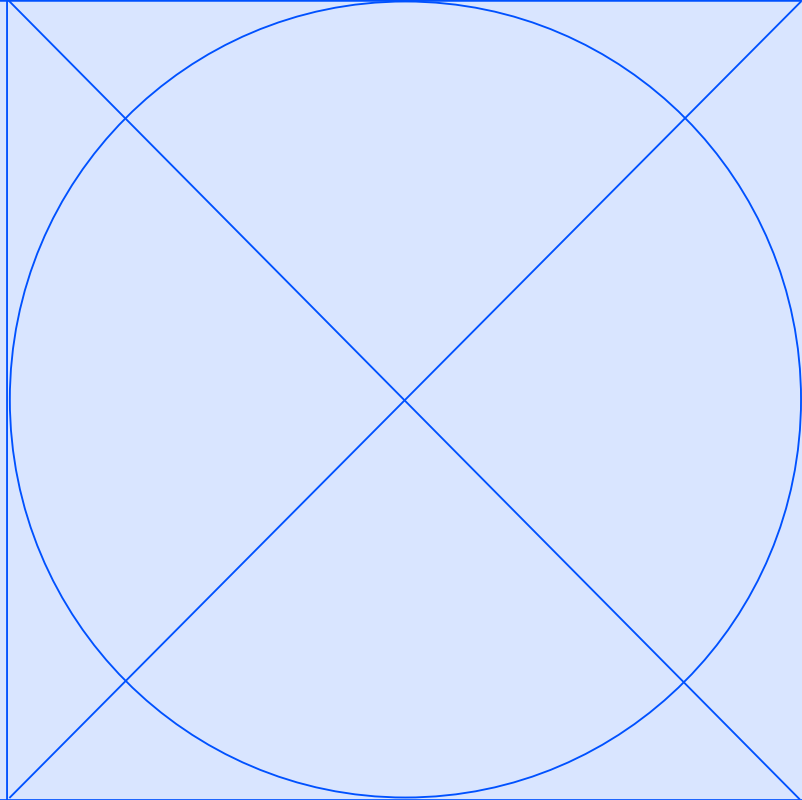
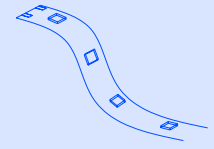

LED Strips

Bandeaux à LED

Asai



+ Asai 3D



16 mm



8 mm

Asai 3D adapts easily to any contour and environment, creating continuous and infinite effects. It offers excellent flexibility and resistance thanks to its extruded polyurethane casing.

Asai 3D s'adapte facilement à tout contour et environnement, créant des effets continus et infinis. Il affiche une flexibilité et une résistance extraordinaires, grâce à son corps extrudé en polyuréthane.



Asai 3D allows infinite curves thanks to its flexibility

Asai 3D permet des courbes infinies grâce à sa flexibilité.

IP68 connectors for fast connection

Connecteurs IP68 pour une connexion rapide





IP65. IK10. Suitable for outdoor use
in which the luminaire is exposed to
the elements

IP65. IK10. Convient aux extérieurs à
impact environnemental sur le luminaire







Adaptation to all types of surfaces thanks to its
3D flexibility and ease of cutting
Adaptation à toutes sortes de surfaces grâce à sa
flexibilité 3D et à sa facilité de découpe

Available in sizes of 1 and 8 m, they can be cut every 10 cm to adjust to the length of the space being lit.
Disponible en tailles de 1 et 8 m, il peut se couper tous les 10 cm pour s'ajuster à la longueur de l'espace à éclairer.



Novotel. Madagascar, 2022.

**Asai 3D 8mm
1000mm**

BODY MAT
PVC

DIF MAT
PVC



50000h
L80 B20

IP
67

IK
10

*** + ***
8 m

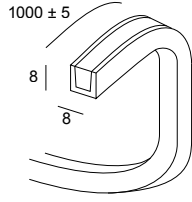
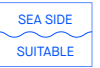

LED					24VDC
K	CRI	W	Real Lm	Code	
3000	90	4.6	331	91-A035 - 00 - 00	
4000	90	4.6	367	91-A036 - 00 - 00	

**Asai 3D 8mm
5000m**

BODY MAT
PVC

DIF MAT
PVC



50000h
L80 B20

IP
67

IK
10

*** + ***
8 m

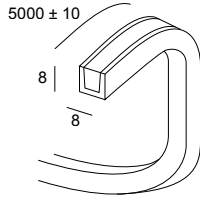
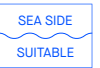

LED					24VDC
K	CRI	W	Real Lm	Code	
3000	90	23	1656	91-A038 - 00 - 00	
4000	90	23	1837	91-A039 - 00 - 00	

**Asai 3D 16mm
1000m**

BODY MAT
PVC

DIF MAT
PVC



50000h
L80 B20

IP
67

IK
10

*** + ***
8 m

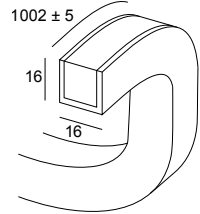
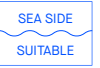

LED					24VDC
K	CRI	W	Real Lm	Code	
3000	80	14.4	972	91-A000 - 00 - 00	
4000	80	14.4	984	91-A002 - 00 - 00	
RGB		14.4	276	91-A004 - 00 - 00	

**Asai 3D 16mm
8000m**

BODY MAT
PVC

DIF MAT
PVC



50000h
L80 B20

IP
67

IK
10

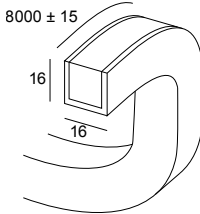
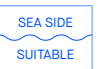

*** + ***
8 m



LED					24VDC
K	CRI	W	Real Lm	Code	
3000	80	115.2	7776	91-A001 - 00 - 00	
4000	80	115.2	7872	91-A003 - 00 - 00	
RGB		115.2	2208	91-A005 - 00 - 00	

Asai 3D 8mm
Asai 3D 16mm
Asai 3D RGB

Fixing accessories
Accessoires de fixation

	Clips (20u.) Clips (20 u.)	71-B456-00-00	71-6607-00-00	71-6607-00-00
	2m flexible profile Profilé 2 m flexible	71-B457-00-00	71-7698-00-00	71-7698-00-00
	2m rigid profile Profilé 2 m rigide	71-B458-00-00	71-6608-00-00	71-6608-00-00

Connection accessories
Accessoires de connexion

	Cable with waterproof tongue and groove connectors (1 m) Câble avec connecteurs étanches mâle-femelle (1 m)	71-B679-00-00	71-E034-00-00	-
	Cable with waterproof tongue and groove connectors (3 m) Câble avec connecteurs étanches mâle-femelle (3 m)	71-B680-00-00	-	-
	Cable with waterproof tongue and groove connectors (5 m) Câble avec connecteurs étanches mâle-femelle (5 m)	-	71-E004-00-00	-
	RGB Cable with waterproof tongue and groove connectors (1 m) Câble RGB avec connecteurs étanches mâle-femelle (1 m)	-	-	71-E071-00-00
	RGB Cable with waterproof tongue and groove connectors (5 m) Câble RGB avec connecteurs étanches mâle-femelle (5 m)	-	-	71-E005-00-00

Power supplies
Sources d'alimentation

P. 988

Connective controllers
Contrôleurs connectés

P. 969

 **Consult the available control systems / Consultez les systèmes de contrôle disponibles:**
 DALI2 / DALI2
 Bluetooth wireless / Sans fil Bluetooth
 Autonomous / Autonome

On

Essential
SOLUTION

+ On



A flexible strip collection with a wide range of outputs and options that allow you to achieve any effect and enhance settings with subtle lighting from a contour that goes unnoticed, adjusting to shapes and structures.

Collection de rubans flexibles offrant un vaste éventail de puissances et d'options qui permettent d'obtenir n'importe quel effet et de souligner le décor. Le tout avec un éclairage subtil à partir d'un contour qui passe inaperçu en épousant les formes et les structures.



On basic in retail project. Pilma Madrid. Photograph: Javier Marquez.
On basic dans un projet de vente au détail. Pilma Madrid. Photographie : Javier Marquez.

Option to control the light beam thanks
to available accessories

Possibilité de contrôler le faisceau
lumineux grâce aux accessoires
disponibles



Smart functionality Fonctionnalité Smart

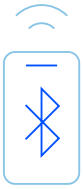

Allows you to create light scenes that adapt to the communication needs and concept of the space.

Possibilité de créer des scènes lumineuses pour répondre aux besoins de communication et au concept de l'espace.



INDOOR



IP65 options suitable for outdoor use
Options IP65 adaptées à l'extérieur

LED STRIPS | BANDEAUX À LED

On Basic 4,8



50000h
L80 B20

3
MacAdam

IP
20

••• + •••
10 m

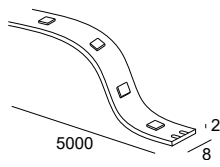

LED					24VDC
K	CRI	W	Real Lm	Code	
2700	80	24	2428	91-7908 - 00 - 00	
3000	80	24	2524	91-7909 - 00 - 00	
4000	80	24	2621	91-7910 - 00 - 00	
6000	80	24	2710	91-7911 - 00 - 00	

On Basic 4,8 RGB



50000h
L80 B20

3
MacAdam

IP
20

RGB LIGHT

••• + •••
10 m

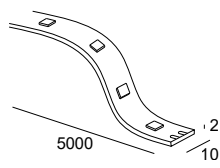

LED				24VDC
K	W	Real Lm	Code	
RGB	24	1402	91-A012 - 00 - 00	

On Basic 4,8 IP65



50000h
L80 B20

3
MacAdam

IP
65

BREEAM

••• + •••
8 m

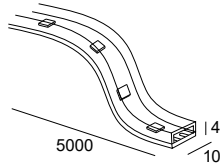

LED					24VDC
K	CRI	W	Real Lm	Code	
2700	80	24	1820	91-7912 - 00 - 00	
3000	80	24	1890	91-7913 - 00 - 00	
4000	80	24	1965	91-7914 - 00 - 00	
6000	80	24	2137	91-7915 - 00 - 00	

On Basic 9,6



50000h
L80 B20

3
MacAdam

IP
20

••• + •••
8 m

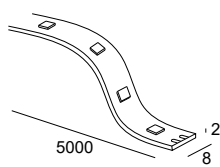

LED					24VDC
K	CRI	W	Real Lm	Code	
2500	80	48	4400	91-3282 - 00 - 00	
2700	80	48	4916	91-7916 - 00 - 00	
3000	80	48	5113	91-7917 - 00 - 00	
4000	80	48	5309	91-7918 - 00 - 00	
6000	80	48	5495	91-7919 - 00 - 00	

On Basic 9,6 RGB



50000h
L80 B20

3
MacAdam

IP
20

RGB LIGHT

••• + •••
6 m

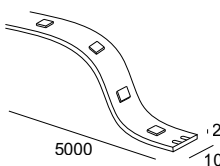

LED				24VDC
K	W	Real Lm	Code	
RGB	48	2607	91-7920 - 00 - 00	

On Basic 9,6 IP65



50000h
L80 B20

3
MacAdam

IP
65

BREEAM

+++
6 m

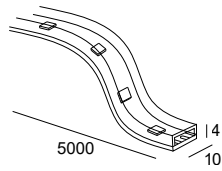

LED						24VDC
K	CRI	W	Real Lm	Code		
2700	80	48	4572	91-7921 - 00 - 00		
3000	80	48	4750	91-7922 - 00 - 00		
4000	80	48	4937	91-7923 - 00 - 00		
6000	80	48	5172	91-7924 - 00 - 00		

On Basic 9,6 IP65 RGB



50000h
L80 B20

3
MacAdam

IP
65

BREEAM

RGB LIGHT

+++
6 m

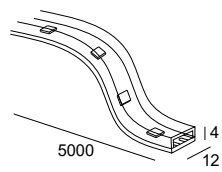

LED				24VDC
K	W	Real Lm	Code	
RGB	48	2427	91-7925 - 00 - 00	

On Basic 4,8 / 9,6



On Basic RGB 4,8 / 9,6



On Basic IP65 4,8 / 9,6



On Basic IP65 RGB 4,8 / 9,6



Joint accessories

Accessoires de raccord



Joint (5u.)
Raccord (5 u.)

71-8093-00-00

-

71-8095-00-00

-

RGB joint (5u.)
Raccord RGB (5 u.)

-

71-8097-00-00

-

71-8099-00-00

Connection accessories

Accessoires de connexion



Starter connector 2 cables (5u.)
Connecteur de début 2 câbles (5 u.)

71-8092-00-00

-

71-8094-00-00

-

Starter connector 4 cables (5u.)
Connecteur de début 4 câbles (5 u.)

-

71-8096-00-00

-

71-8098-00-00

Power supplies

Sources d'alimentation

P. 986

Connective controllers

Contrôleurs connectés

P. 969



Consult the available control systems / Consultez les systèmes de contrôle disponibles:

DALI2 / DALI2

Bluetooth wireless / Sans fil Bluetooth

Autonomous / Autonome

On Basic 14,4

IP	+++ +	LED
20	7 m	

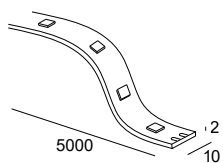

LED					24VDC
K	CRI	W	Real Lm	Code	
2700	80	72	8952	91-7926 - 00 - 00	
3000	80	72	9309	91-7927 - 00 - 00	

On Basic 14,4 RGB

IP	RGB LIGHT	+++ +	LED
20		6 m	

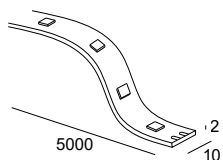

LED				24VDC
K	W	Real Lm	Code	
RGB	72	4755	91-2379 - 00 - 00	

On Basic 14,4 IP65

IP	+++ +	LED
65	5 m	

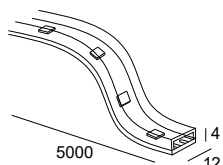

LED					24VDC
K	CRI	W	Real Lm	Code	
3000	80	72	9879	91-A013 - 00 - 00	

On Basic 14,4



On Basic 14,4 RGB



On Basic 14,4 IP65



Joint accessories

Accessoires de raccord



Joint (5u.) IP20
Raccord (5 u.) IP20

71-B422-00-00

-

71-B424-00-00

RGB joint (5u.)
Raccord RGB (5 u.)

-

71-8097-00-00

-

Connection accessories
Accessoires de connexion



Starter connector 2 cables (5u.)
Connecteur de début 2 câbles (5 u.)

71-B421-00-00

-

71-8099-00-00

Starter connector 4 cables (5u.)
Connecteur de début 4 câbles (5 u.)

-

71-8096-00-00

-

Power supplies

Sources d'alimentation

P. 986

Connective controllers

Contrôleurs connectés

P. 969



Consult the available control systems / Consultez les systèmes de contrôle disponibles:
DALI2 / DALI2
Bluetooth wireless / Sans fil Bluetooth
Autonomous / Autonome

On Basic 19,2

	50000h L80 B20	3 MacAdam	IP 20		
--	-------------------	--------------	----------	--	--

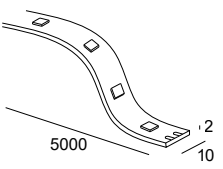

LED					24VDC
K	CRI	W	Real Lm	Code	
2700	80	96	11363	91-7928 - 00 - 00	
3000	80	96	11503	91-7929 - 00 - 00	
4000	80	96	11725	91-A014 - 00 - 00	
6000	80	96	11967	91-A015 - 00 - 00	

On Basic 19,2 IP65

	50000h L80 B20	3 MacAdam	IP 65		
--	-------------------	--------------	----------	--	--

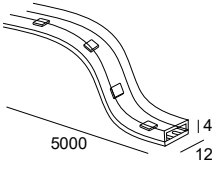

LED					24VDC
K	CRI	W	Real Lm	Code	
2700	80	96	11187	91-A016 - 00 - 00	
3000	80	96	11190	91-5567 - 00 - 00	

**On Basic 19,2
2700K/3000
4000K/6000K**



**On Basic 19,2
IP65**



Joint accessories
Accessoires de raccord

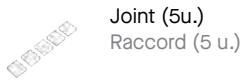

Joint (5u.)
Raccord (5 u.)

71-B449-00-00

71-B451-00-00

Accesorios de conexión
Accessórios de conexão



Starter connector 2 cables (5u.)
Connecteur de début 2 câbles (5 u.)

71-B450-00-00

71-B452-00-00

Power supplies
Sources d'alimentation

P. 986

Connective controllers
Contrôleurs connectés

P. 969



Consult the available control systems / Consultez les systèmes de contrôle disponibles:
DALI2 / DALI2
Bluetooth wireless / Sans fil Bluetooth
Autonomous / Autonome

On Basic 28,8

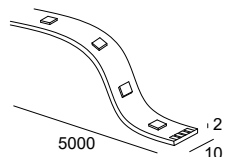
50000h
L80 B203
MacAdamIP
20***+***
5 m

LED					24VDC
K	CRI	W	Real Lm	Code	
2700	80	144	13950	91-5571 - 00 - 00	
3000	80	144	14405	91-5572 - 00 - 00	
4000	80	144	15635	91-5573 - 00 - 00	

Joint accessories

Accessoires de raccord



Starter connector 2 cables (5u.)
Connecteur de début 2 câbles (5 u.)

71-B421-00-00

Joint (5u.) IP20
Raccord (5 u.) IP20

71-B422-00-00

Power supplies

Sources d'alimentation

P. 986

Connective controllers

Contrôleurs connectés

P. 969



Consult the available control systems / Consultez les systèmes de contrôle disponibles:

DALI2 / DALI2

Bluetooth wireless / Sans fil Bluetooth

Autonomous / Autonome

On Performance 9,6

3		50000h	IP	+++ +	
MacAdam		L80 B20	20	6 m	

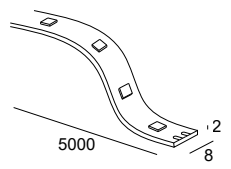

LED					24VDC
K	CRI	W	Real Lm	Code	
2700	90	48	4264	91-7930	- 00 - 00
3000	90	48	4520	91-7931	- 00 - 00
4000	90	48	4725	91-A017	- 00 - 00

On Performance 9,6 RGBW

3		50000h	IP	+++ +	
MacAdam		L80 B20	20	8 m	

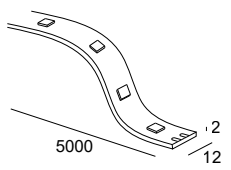

LED					24VDC
K	CRI	W	Real Lm	Code	
RGBW	80	48	2688	91-A019	- 00 - 00

On Performance 9,6 IP65

	3	50000h	IP	+++ +	
	MacAdam	L80 B20	20	5 m	

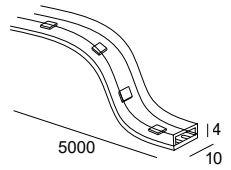

LED					24VDC
K	CRI	W	Real Lm	Code	
3000	90	48	4290	91-A020	- 00 - 00

On Performance 9,6 IP65 RGBW

	3	50000h	IP	+++ +	
	MacAdam	L80 B20	20	5 m	

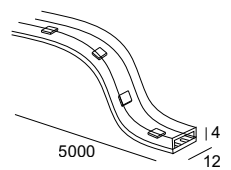

LED					24VDC
K	CRI	W	Real Lm	Code	
RGBW	80	48	2576	91-A021	- 00 - 00

Power supplies
Sources d'alimentation

P. 988

Connective controllers
Contrôleurs connectés

P. 969



Consult the available control systems / Consultez les systèmes de contrôle disponibles:
DALI2 / DALI2
Bluetooth wireless / Sans fil Bluetooth
Autonomous / Autonome

On Performance 19,2



50000h
L80 B20

3
MacAdam

IP
20

••• + •••
5 m

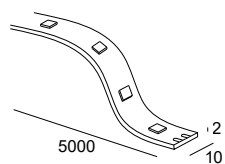

LED					24VDC
K	CRI	W	Real Lm	Code	
2700	90	96	7966	91-7934 - 00 - 00	
3000	90	96	8193	91-7935 - 00 - 00	
4000	90	96	8305	91-7936 - 00 - 00	

On Performance 19,2 RGB



50000h
L80 B20

3
MacAdam

IP
20

••• + •••
5 m

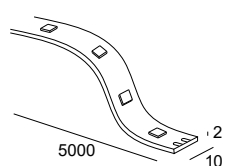

LED					24VDC
K	CRI	W	Real Lm	Code	
RGB		72	3192	91-7937 - 00 - 00	
RGB-3000	90	96	4574	91-7938 - 00 - 00	
2700-6500	90	96	7973	91-7939 - 00 - 00	

On Performance 19,2 IP65



50000h
L80 B20

3
MacAdam

IP
20

••• + •••
5 m

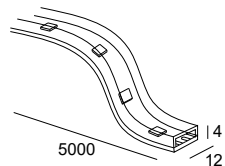

LED					24VDC
K	CRI	W	Real Lm	Code	
2700	90	96	7666	91-A024 - 00 - 00	
3000	90	96	7947	91-A025 - 00 - 00	

Power supplies Sources d'alimentation

P. 988

Connective controllers Contrôleurs connectés

P. 969



Consult the available control systems / Consultez les systèmes de contrôle disponibles:
 DALI2 / DALI2
 Bluetooth wireless / Sans fil Bluetooth
 Autonomous / Autonome

On Performance 28,8



50000h L80 B20

3 MacAdam

IP 20

5 m

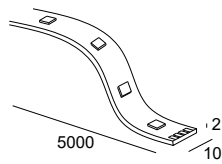

LED					24VDC	
K	CRI	W	Real Lm	Code		
2700	90	120	12643	91-7940 - 00 - 00		
3000	90	120	14510	91-7941 - 00 - 00		

On Performance COB



50000h L80 B20

3 MacAdam

IP 20

5 m

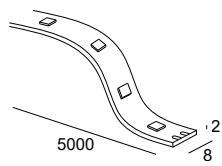

LED					24VDC	
K	CRI	W	Real Lm	Code		
3000	90	40	2586	91-A026 - 00 - 00		

Power supplies
Sources d'alimentation

P. 988

Connective controllers
Contrôleurs connectés

P. 969



Consult the available control systems / Consultez les systèmes de contrôle disponibles:

DALI2 / DALI2

Bluetooth wireless / Sans fil Bluetooth

Autonomous / Autonome

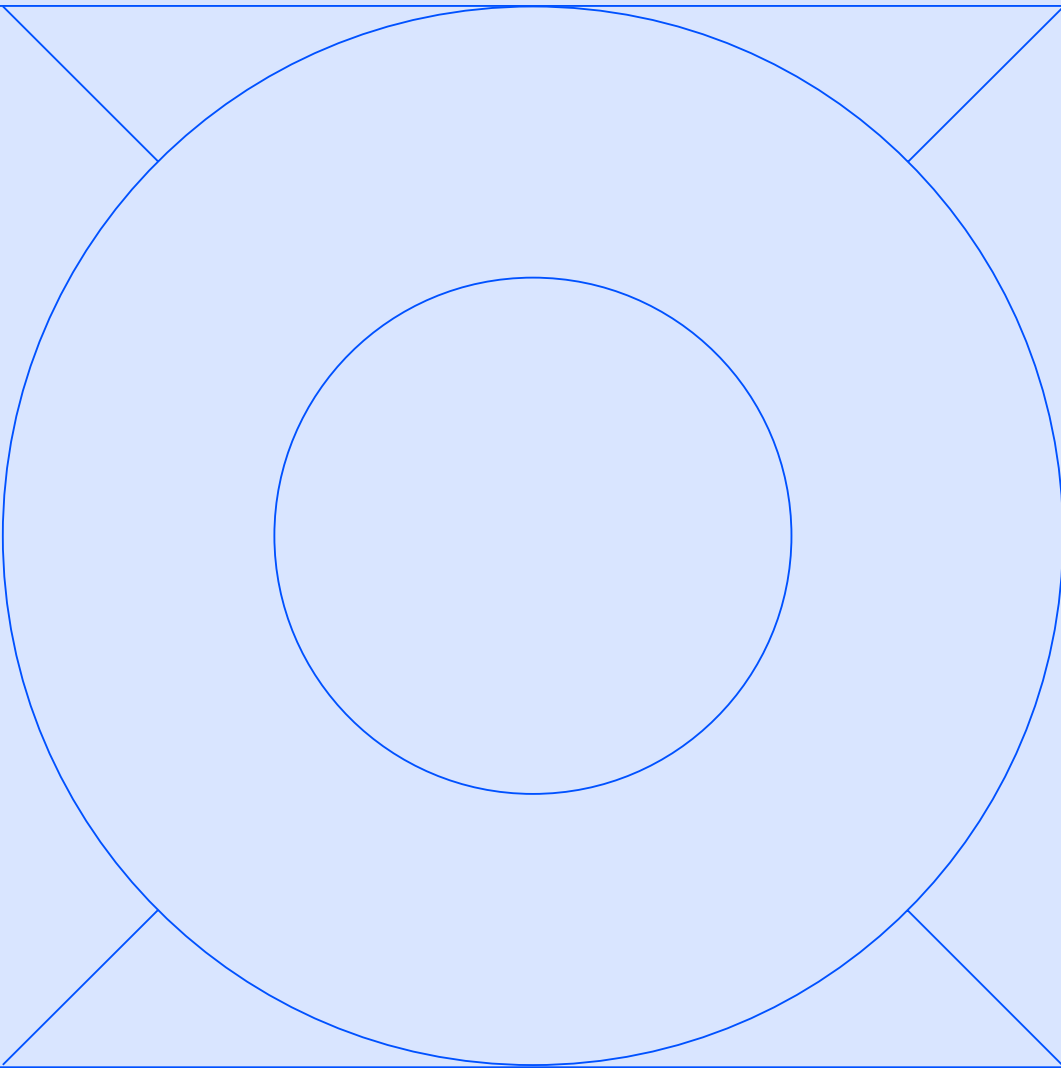

Outdoor



435
Outdoor
Collections

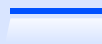

476
Lineal Light Systems
Systèmes d'Éclairage
Linéaires



528
Spotlights
Projecteurs



584
Underwater
Submersibles



596
Recessed downlights
Encastrés de plafond



611
Recessed wall lights
Encastrés de mur



628
Recessed floor
lights
Encastrés de sol



684
Surface uplights
Encastrés de
surface



698
Bollards / Lamppost
Balises / Réverbères



780
Wall fixtures
Appliques



850
Ceilings
Plafonniers



874
Chillout



914
Easy Safe Garden

Outdoor Collections

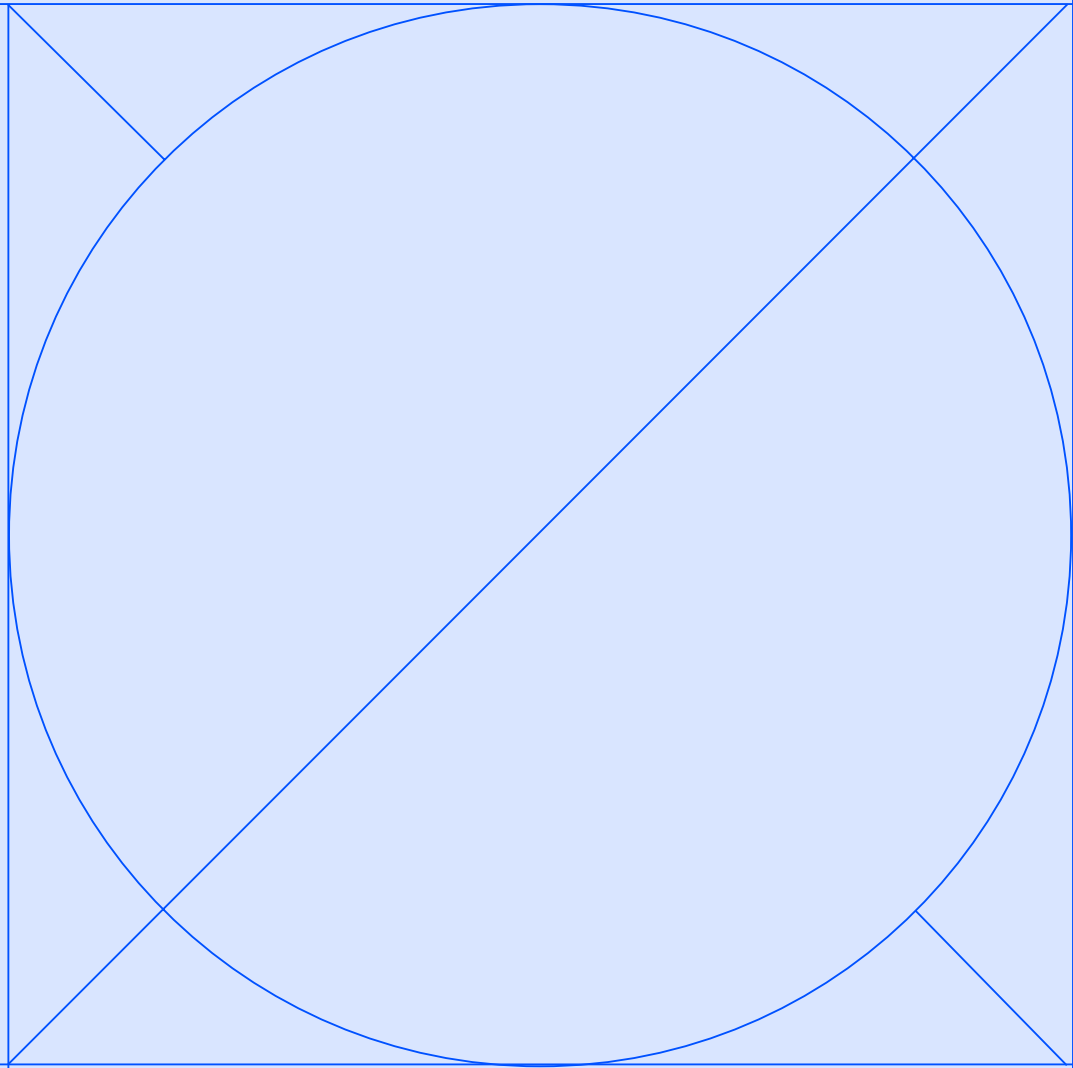

Eko
436

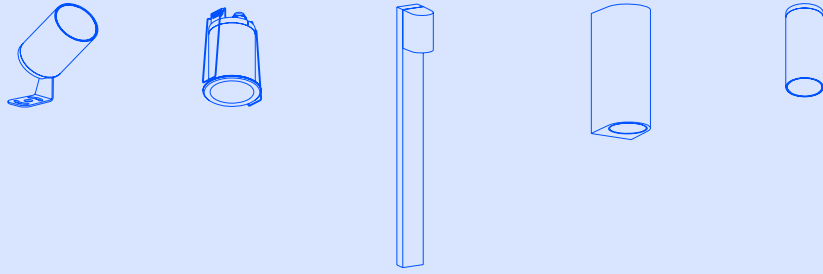

Max
440

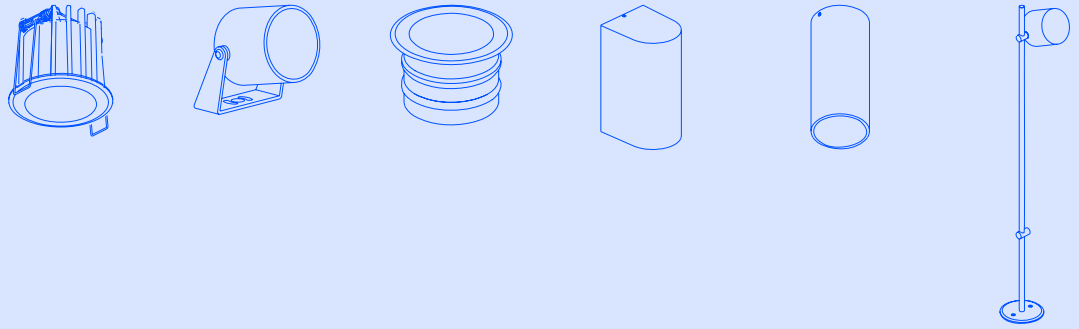

Modis
450

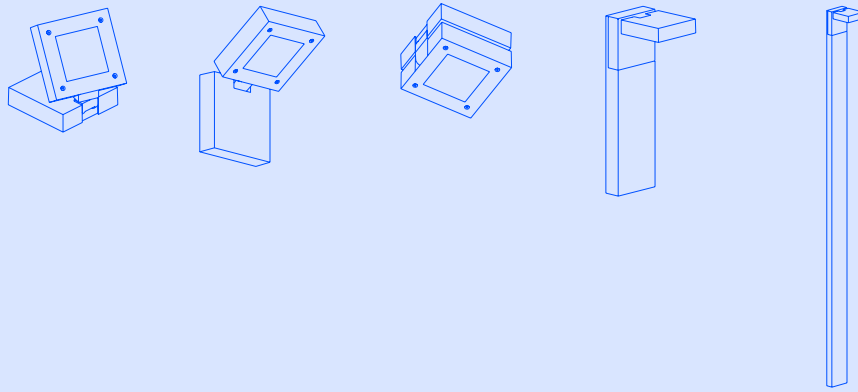

Orbit
458

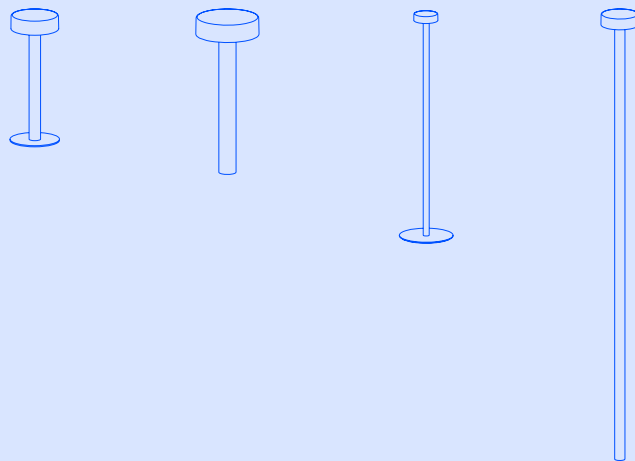

Rack
466

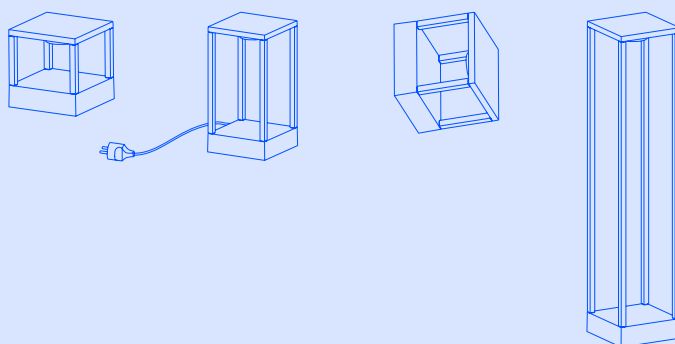

Eko

Designed by LedsC4 Architectural



Spotlight
P. 550



Downlight
P. 608



Bollard
P. 744



Wall Fixtures
P. 794



Ceiling
P. 856



The most comprehensive essential GU10 collection La collection essentielle GU10 la plus complète

This collection is perfect for projects seeking an affordable, highly reliable solution for various applications. It's notable for the versatility of its models, options and features, along with its easy installation and maintenance.

Cette collection est idéale pour les projets qui recherchent une solution abordable et fiable afin de répondre à des applications diverses. Elle se distingue par la polyvalence des modèles, des options et des prestations, ainsi que par sa facilité d'installation et d'entretien.



14



34



DL



E3



J6



Z5



60







2-second bulb replacement system Système de changement de lampes en 2 secondes

Ultra-fast bulb replacement during maintenance thanks to an optional accessory.

Changement ultra-rapide des ampoules lors de l'entretien grâce à un accessoire en option.

High resistance with IK07, IP66 rating Grande résistance IK07, IP66

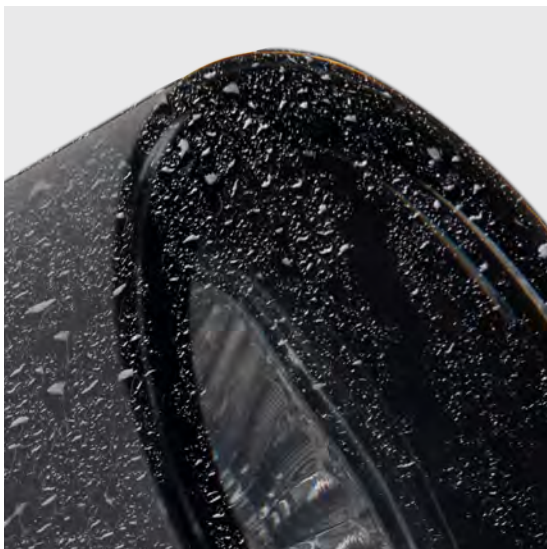

Venting valve reduces LED bulb overheating La valve d'aération réduit la surchauffe des ampoules LED

Facilitates air circulation, extending the lifespan of LED bulbs.

Facilite la circulation de l'air, prolongeant ainsi la durée de vie des ampoules LED.





An essential with every detail taken care of
Essentiel sans compromettre les détails

Max

Designed by LedsC4 Architectural



+ Max

Spotlights
P. 540



Downlights
P. 598



Uplights
P. 630



Bollards
P. 738



Wall Fixture
P. 788



Ceiling
P. 852



In-out LED lighting Éclairage LED in-out

This extensive collection, offering different applications and combinations, is designed to light new spaces in which indoor and outdoor are more connected than ever, sharing the same concept and architecture.

Cette vaste collection, avec ses différentes applications et combinaisons, est conçue pour éclairer de nouveaux espaces, dans lesquels l'intérieur et l'extérieur sont plus connectés que jamais, partageant un même concept et une même architecture.



14



34



DL



E3

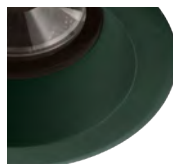

J6



Z5



60





Downlight
598

Uplight
630

Comfort

Round

Square

Trimless

Round

Square

Ø 58 mm

Ø 47 mm

∅ 47 mm

Ø 32 mm

Ø 47 mm

∅ 47 mm



CA

CA 17 18

CA 17 18

Ø 100 mm

Ø 75 mm

∅ 75 mm

Ø 58 mm

Ø 75 mm

∅ 75 mm



Z5

CA 17 18

CA 17 18

Ø 140 mm

Ø 110 mm

∅ 110 mm

Ø 83 mm

Ø 110 mm

∅ 110 mm



CA

CA 17 18

CA 17 18

2700K/3000K/4000K
2.2 - 17.3 W

2700K/3000K/4000K
2.2 - 17.3 W



US - UF

US - UF

○ ● ● ● ● ● ● ● ● ● ● ● ●
14 60 34 DL E3 J6 Z5 CA 17 18



Spotlight
540

Bollard
738

Wall Fixture
788

Ceiling
852

Surface

Single Emission

Double Emission

Ceiling

Ø 30 mm

Ø 30 mm x H 450 mm

L 85 x W 62 x H 100 mm

L 85 x W 62 x H 135 mm

Ø 58 x H 160 mm



Ø 58 mm

Ø 58 mm x H 600 mm

L 85 x W 62 x H 204 mm

L 85 x W 62 x H 245 mm

Ø 58 x H 251 mm



Ø 82 mm

Ø 82 mm x H 800 mm

L 92 x W 113 x H 200 mm

L 92 x W 113 x H 280 mm

Ø 83 x H 230 mm



2700K/3000K/4000K
2.2 - 17.3 W



US - UF

○ ● ● ● ● ● ● ●
14 60 34 DL E3 J6 Z5

2700K/3000K/4000K
4 - 31,5 W



US - UF

○ ● ● ● ● ● ● ●
14 60 34 DL E3 J6 Z5



US - UF

2700K/3000K/4000K
4 - 17,3 W



US - UF

○ ● ● ● ● ● ● ●
14 60 34 DL E3 J6 Z5



Max

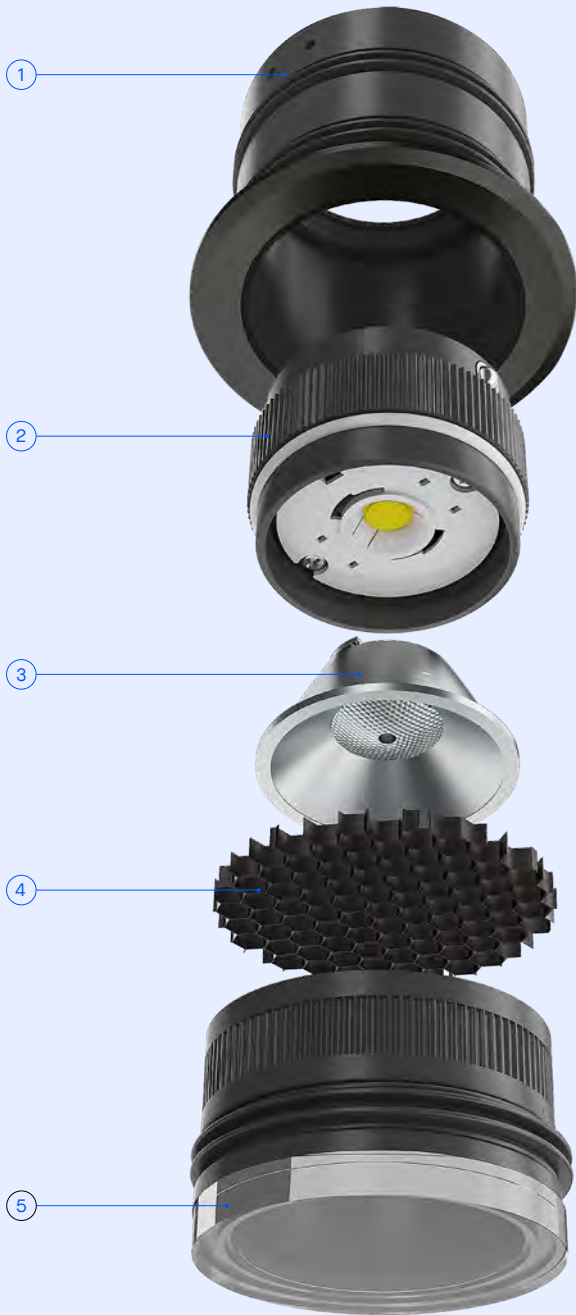

4 Lens accessories Accessoires optiques

- 1 Elliptical diffuser (5u.)
Diffuseur elliptique (5 u.)
- 2 Square diffuser (5u.)
Diffuseur carré (5 u.)
- 3 Opal diffuser (5u.)
Diffuseur opalin (5 u.)
- 4 Honeycomb panel (5u.)
Grille en nid d'abeille (5 u.)
- 5 Wall washer diffuser (5u.)
Diffuseur lèche-mur (5 u.)



1 Structure
Structure
Downlight Trimless
Downlight Round
Downlight Square

2 LED modules
eco-designed to be replaceable
Modules LED
écoconçus pour être remplaçables

3 Lens
Optique
Opening angles:
8,6° - 17° - 27° - 50°
Angles d'ouverture:
8,6° - 17° - 27° - 50°

4 Lens accessories
Accessoires optiques

5 Closure
Fermeture
Watertight closure to guarantee IP66
Fermeture hermétique garantissant IP66

Without diffuser
Sans diffuseur

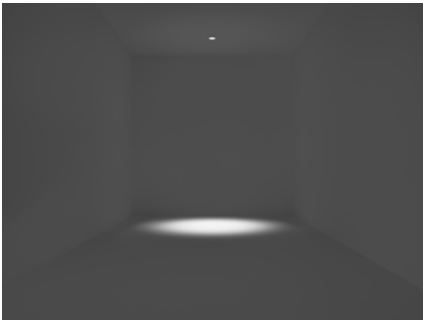

Honeycomb panel
Grille en nid d'abeille



Opal diffuser
Diffuseur opalin

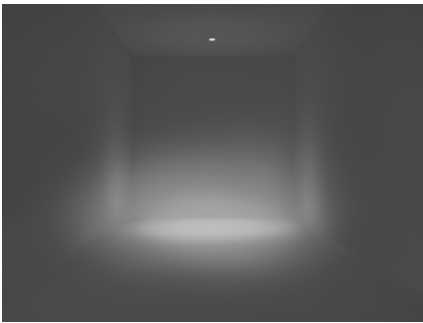

Square diffuser
Diffuseur carré

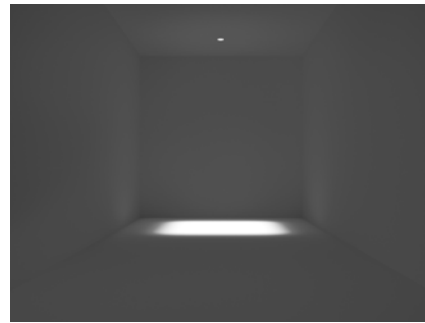

Elliptical diffuser
Diffuseur elliptique



Wall washer diffuser
Diffuseur lèche-mur

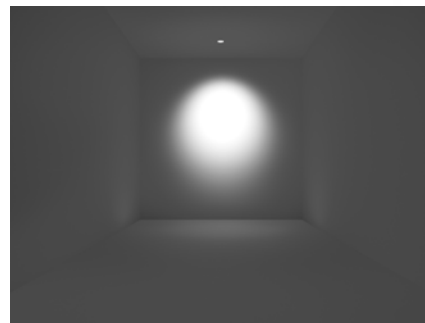

2200K



2700K

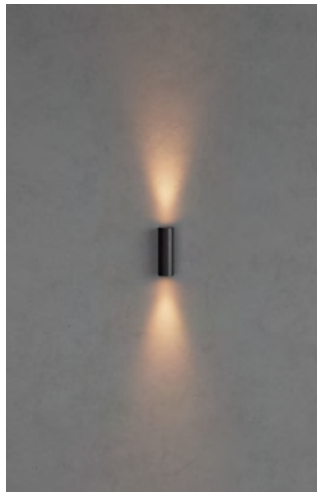

3000K



4000K





New smaller models
Nouveaux modèles plus petits

Wide range of finishes Large gamme de finitions

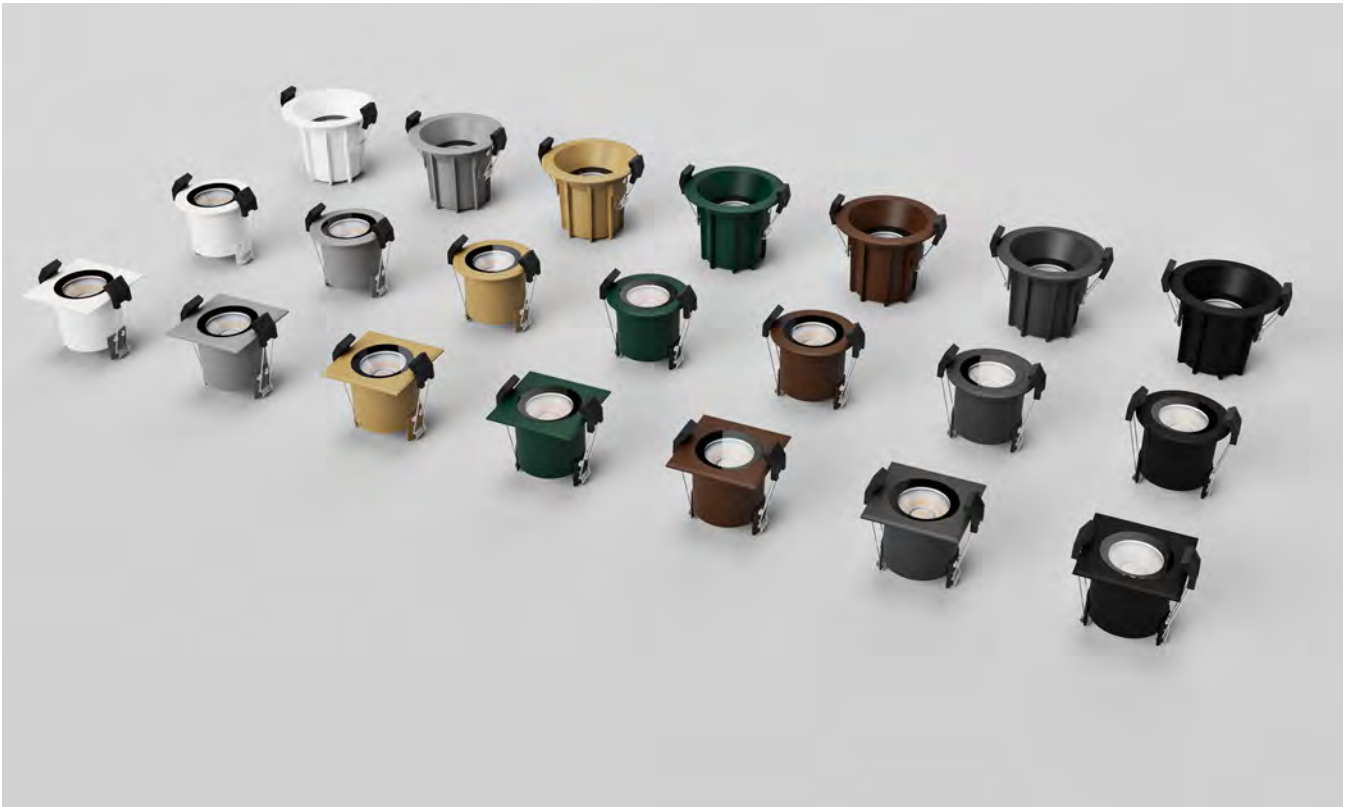

Painted finishes for recessed ceiling lights, spotlights, bollard lights, wall lights and ceiling lights.
Finitions peintes pour encastrés de plafond, projecteurs, balises, appliques et plafonniers.

Small
Ø35mm



Medium
Ø50mm



Big
Ø75mm



Different sizes and outputs for all applications Différentes tailles et puissances pour toutes les applications





Modis

Designed by Luca Turrini



Spotlights
P. 553



Bollards
P. 706

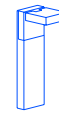

Wall Fixtures
P. 782

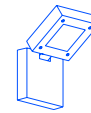

Ceilings
P. 862



Maximum versatility Polyvalence maximale

A collection designed to light different spaces of the same project with elegant and precise lighting. This range stands out for the versatility of models, options and features. The design of its double ball joint allows the head to be moved in any direction to direct the light where it is really needed.

Collection conçue pour éclairer différents espaces d'un même projet de manière élégante et précise. Elle se distingue par la polyvalence des modèles, des options et des prestations qu'elle propose. Le design de sa double rotule permet de déplacer la tête dans n'importe quelle direction pour orienter la lumière là où elle est vraiment nécessaire.

Modis Opal

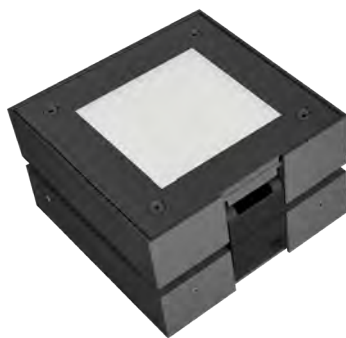

Modis Optics



14



34



DL



E3



J6



Z5

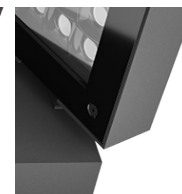

60





Spotlight
553

Wall Fixture
782

Ceiling
862

140 × 140 mm



428 × 140 mm



800 × 140 mm



Opal
13,2 - 26,4 W

Optics
21 - 42 W

Opal
13,2 - 26,4 W

Optics
21 - 42 W

Opal
13,2 - 26,4 W

Optics
21 - 42 W



GL

S - F - UF

GL

S - F - UF

GL

S - F - UF



14 60 34 DL E3 J6 Z5



Bollard
706

Lampost
706

140 × 500 mm

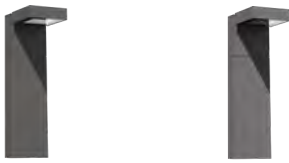

140 × 2300 mm

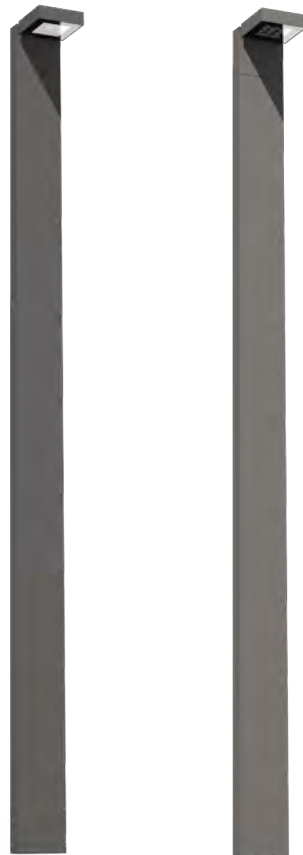

Two Heads

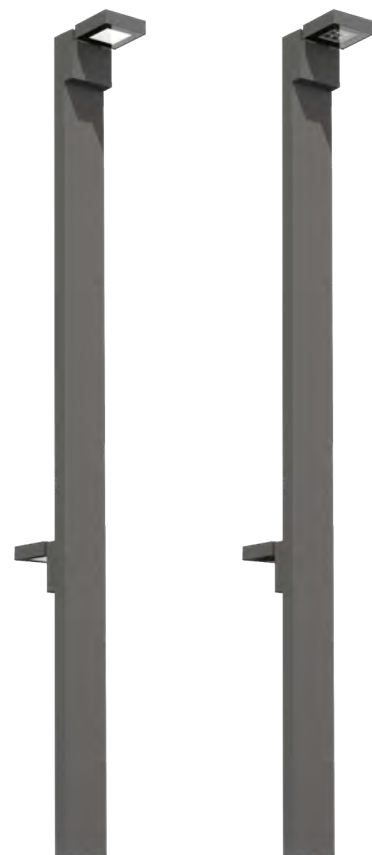

140 × 1000 mm

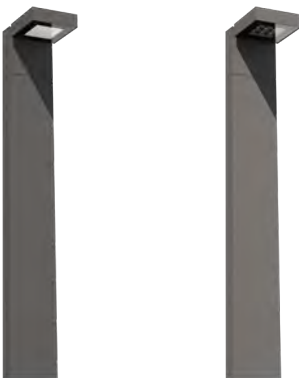

Opal
13,2 - 26,4 W



GL

Optics
21 - 42 W



S - F - UF

Opal
13,2 - 26,4 W



GL

Optics
21 - 42 W



S - F - UF

Opal
13,2 - 26,4 W



GL

Optics
21 - 42 W



S - F - UF

○ ● ● ● ● ● ● ●
14 60 34 DL E3 J6 Z5



Smart

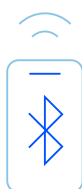

Available in DALI2 and Casambi protocols
Disponible dans les protocoles DALI2 et Casambi

Through its Smart functionality, the Modis collection achieves major energy savings thanks to point-to-point management of luminaires by groups or scenes, by occupancy control and by hourly programmes with timer, among other features.

Grâce à la fonctionnalité Smart, la collection Modis permet de grandes économies d'énergie notamment à travers la gestion des luminaires point à point, par groupes ou scènes, par contrôle par occupation et par programmation horaire.

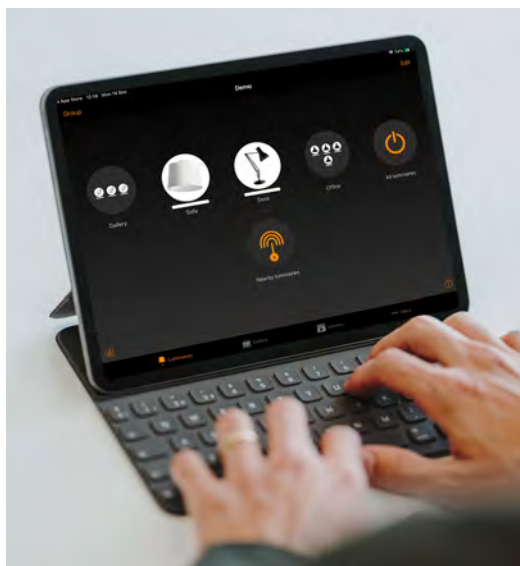

Example of control via Bluetooth Casambi.
 Exemple de contrôle via Bluetooth Casambi.



Head rotation Rotation de la tête

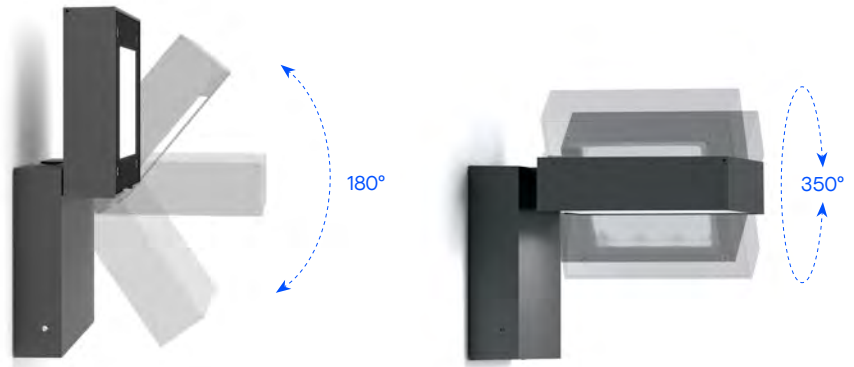

Light effects Effets de lumière

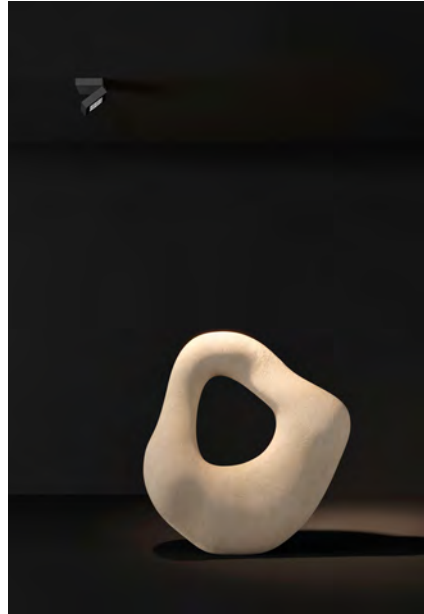

Modis Optics
For focused lighting.
Pour un éclairage focalisé.

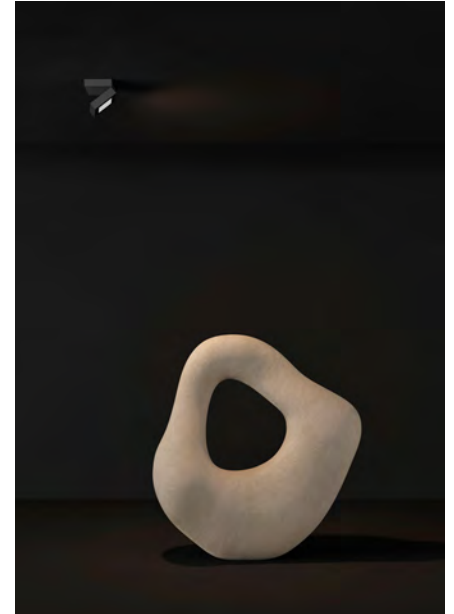

Modis Opal
For general lighting.
Pour un éclairage général.

Available in 2200 K, a temperature that is more
eco-friendly for the local plant and animal life
Disponible en 2 200K, température plus respectueuse
de la faune et la flore environnantes

2200K



2700K



3000K



4000K





Multiple applications with a shared aesthetic
Applications multiples avec la même esthétique



Independently select the height of each head
Permet de choisir la hauteur de chaque tête de façon indépendante



Orbit

Designed by Luca Turrini



Bollards
P. 718



Lamposts
P. 718



Chillout
P. 884



Perfect dialogue between technicality and beauty Dialogue parfait entre technicité et beauté

Detailed and meticulously designed, Orbit is a differential element that transforms the life around it, lighting vegetation, objects or settings with its warm and elegant lighting. The simplicity of its silhouette provides added value, as it surrenders all prominence to the light, which has been painstakingly developed to offer advanced technical features with various options for directing the light beam.

Détaillé et minutieux, Orbit est l'élément différentiel qui transforme la vie qui l'entoure, illuminant la végétation, les objets ou les environnements de manière chaleureuse et élégante. La simplicité de sa ligne apporte une valeur ajoutée, car elle laisse toute sa place à la lumière, qui est travaillée en détail pour offrir des prestations techniques élevées avec diverses options d'orientation du faisceau lumineux.

2300 mm

1200 mm

900 mm

500 mm

335 mm

300 mm

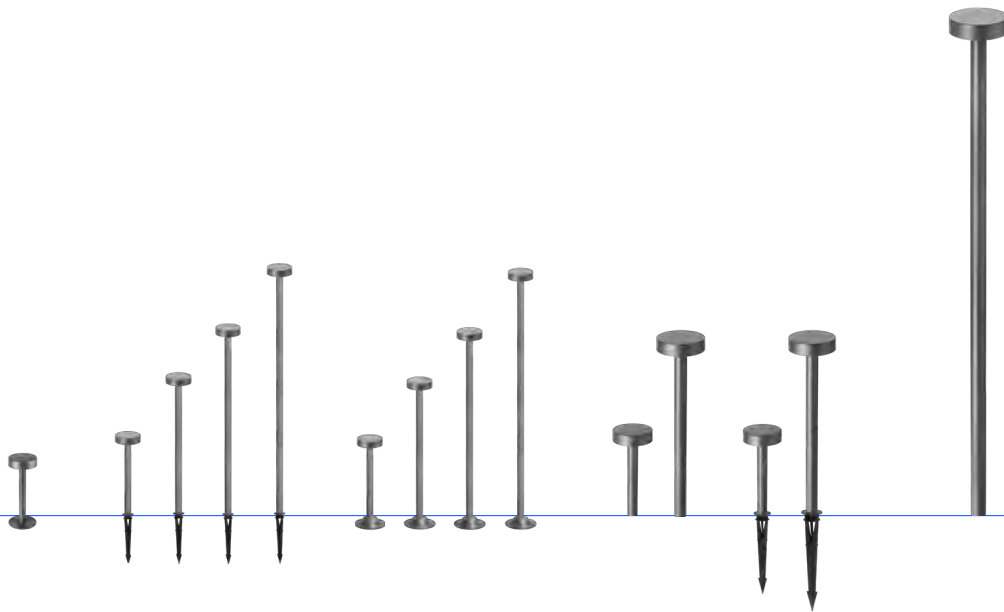

14

34

DL

E3

J6

Z5

60









Light options on the top of the head:
signage point, zero light pollution and soft
upward light

Options d'éclairage dans la partie
supérieure de la tête: point de signalisation,
pollution lumineuse nulle et lumière
douce vers le haut

2700K

3000K

4000K

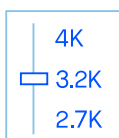

Built-in CCT switch that allows you to change the colour temperature according to the needs of the space.

Switch (interrupteur) CCT intégré qui permet de modifier la température de couleur en fonction des besoins de l'espace.

IK10 anti-vandal diffuser

Diffuseur antivandalisme IK10

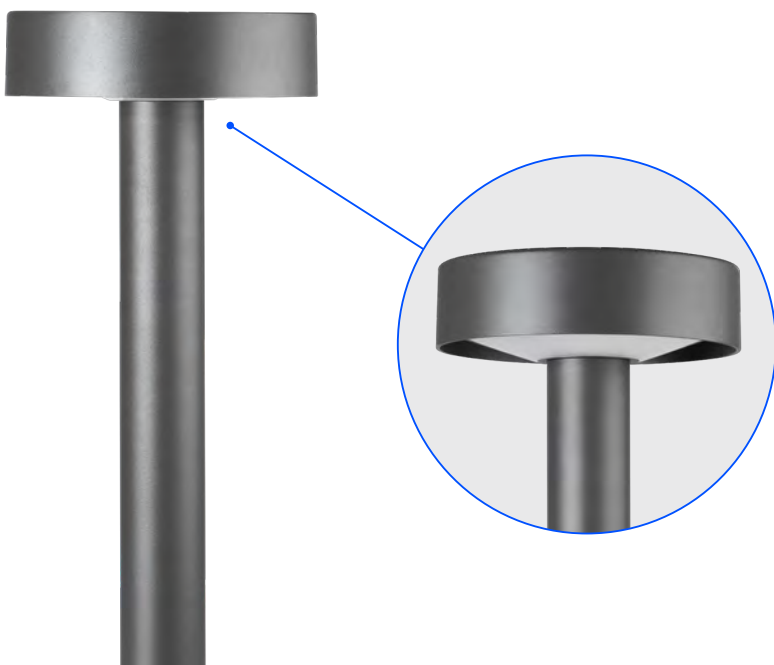



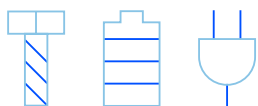

Three power supply options:
Fixed, portable with battery and portable
with cable and plug.

Trois options d'alimentation:
Fixe, portable avec batterie et portable
avec câble et prise.



Rack

Designed by LedsC4 Architectural



+ Rack

Rechargeables
P. 892



Plug&Play
P. 892

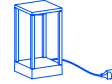

Bollards
P. 892

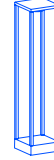

Wall Fixtures
P. 823



Maximum flexibility for superior adaptation Flexibilité maximale pour une meilleure adaptation

It's not easy to find decorative luminaires with advanced performance features, such as an IP66 rating, DALI lighting control, BREEAM efficiency or a special treatment to withstand coastal conditions. Rack has been meticulously developed to light projects in which the reliability of the luminaire is as important as its decorative function.

Il n'est pas facile de trouver des luminaires décoratifs possédant des prestations élevées, telles que la protection IP66, la variation DALI et l'efficacité BREEAM, ou bénéficiant d'un traitement spécial pour résister aux atmosphères marines. Rack a été minutieusement développée pour éclairer des projets qui requièrent des luminaires aussi fiables que décoratifs.



14

34

DL

E3

J6

Z5

60







Rechargeable

892

Plug&Play

892

Bollard

892

Wall Fixtures

823

100 × 100 × 270 mm



150 × 150 × 160 mm



150 × 150 × 300 mm



260 × 260 × 300 mm



150 × 150 × 700 mm



260 × 260 × 900 mm

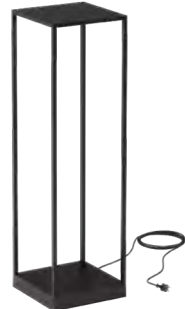

14 60 34 DL E3 J6 Z5



LED light source
Source lumineuse LED

Spherical diffuser accessory
Accessoire diffuseur sphérique



Installations Installations

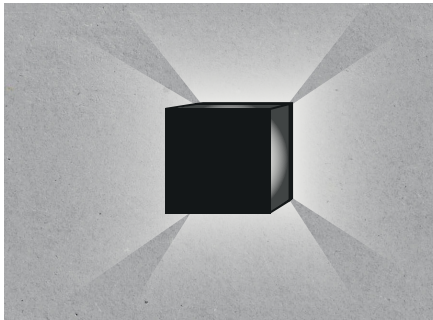

Wall light
Applique

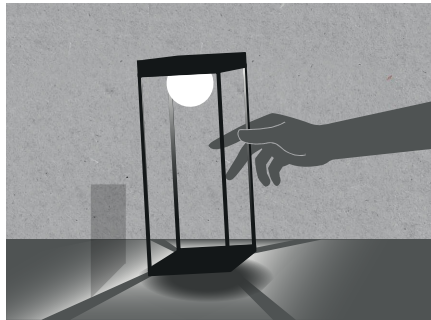

Portable
Portable

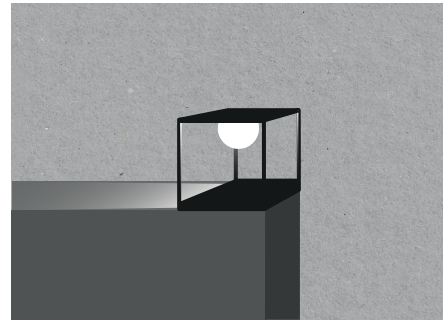

Pedestal light
Borne

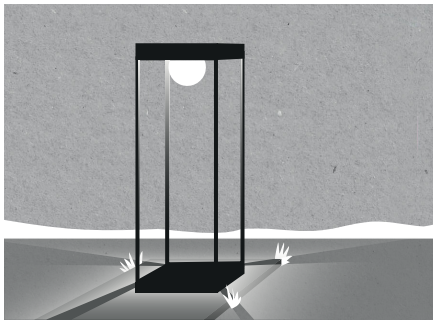

Bollard light
Balise

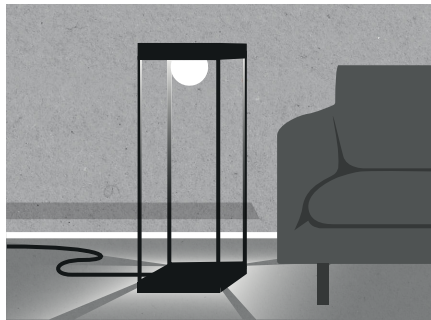

Floor lamp
Lampadaire

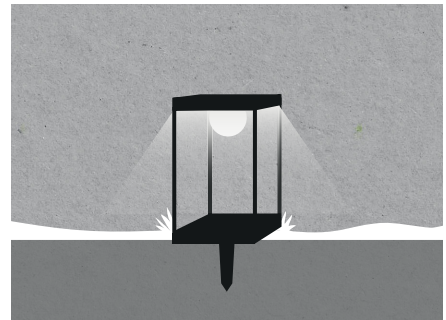

Portable with spike
Portable avec piquet



Rack is a versatile collection that allows multiple combinations to be created

Rack est une collection polyvalente qui permet de créer de multiples combinaisons

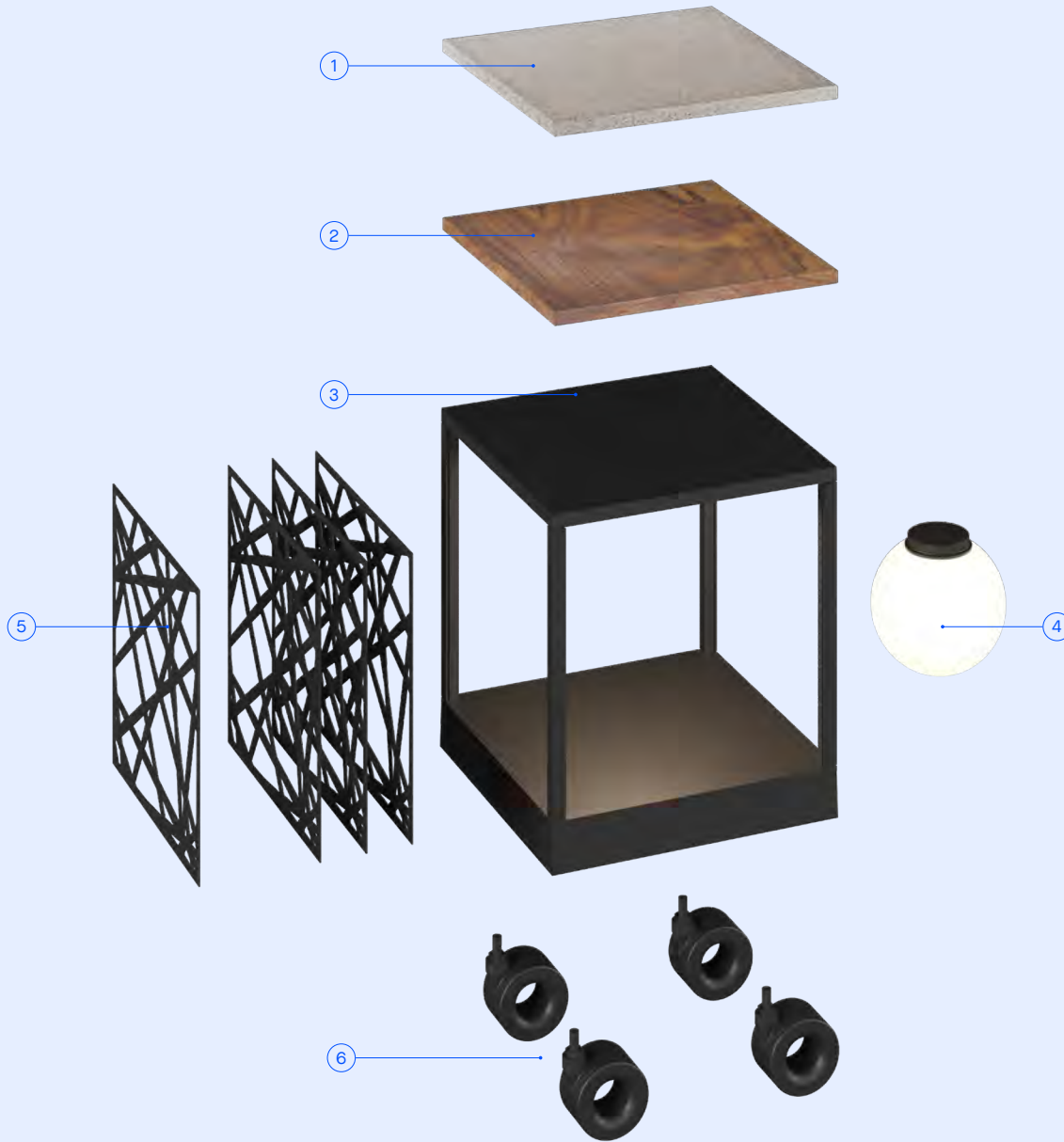

Upper finishes
Finitions supérieures

- ① Cement cover
Cache ciment
- ② Wood cover
Cache bois
- ③ Without cover
Sans cache

Optional accessories
Accessoires en option

- ④ Spherical diffuser
Diffuseur sphérique
- ⑤ Decorative grid set*
Ensemble grille décorative*
- ⑥ Wheels**
Roues**

Structure finishes
Finitions structure



*Available in the colours of the structure finishes.

*Disponible dans les couleurs de finition de la structure.

**Only available for 260×260×300 mm and 260×260×900 mm models.

**Disponible uniquement pour les modèles 260×260×300 mm et 260×260×900 mm.

A design that plays
with light effects
Un design qui joue
sur les effets de lumière



2700K

3000K

4000K



Smart

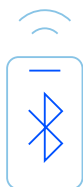

Through its Smart functionality, this model achieves major energy savings thanks to point-to-point management of luminaires by groups or scenes, by occupancy control and by hourly programmes with timer, among other features. La fonctionnalité Smart permet de grandes économies d'énergie notamment à travers la gestion des luminaires point à point, par groupes ou scènes, par contrôle par occupation et par programmation horaire.

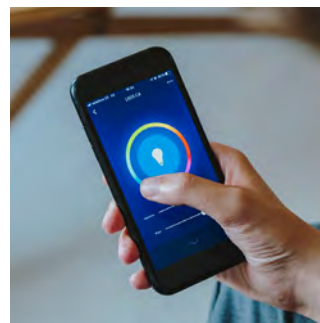

Example of application with control via Bluetooth Casambi. Also available with the DALI2 protocol.

Exemple d'application avec contrôle par Bluetooth Casambi. Également disponible avec le protocole DALI2.

Finished with quality,
high-grade materials
Fini avec qualité,
haute qualité matériaux

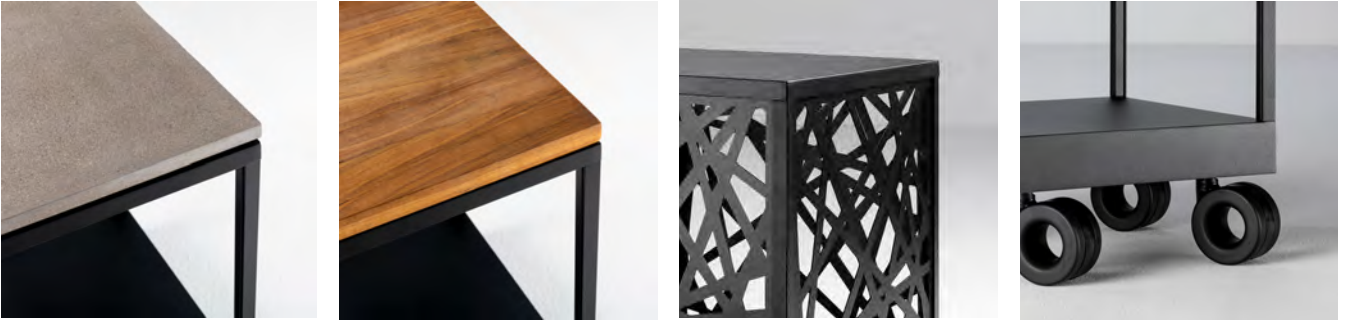

Wheels designed by Philippe Stark
Roues conçues par Philippe Stark

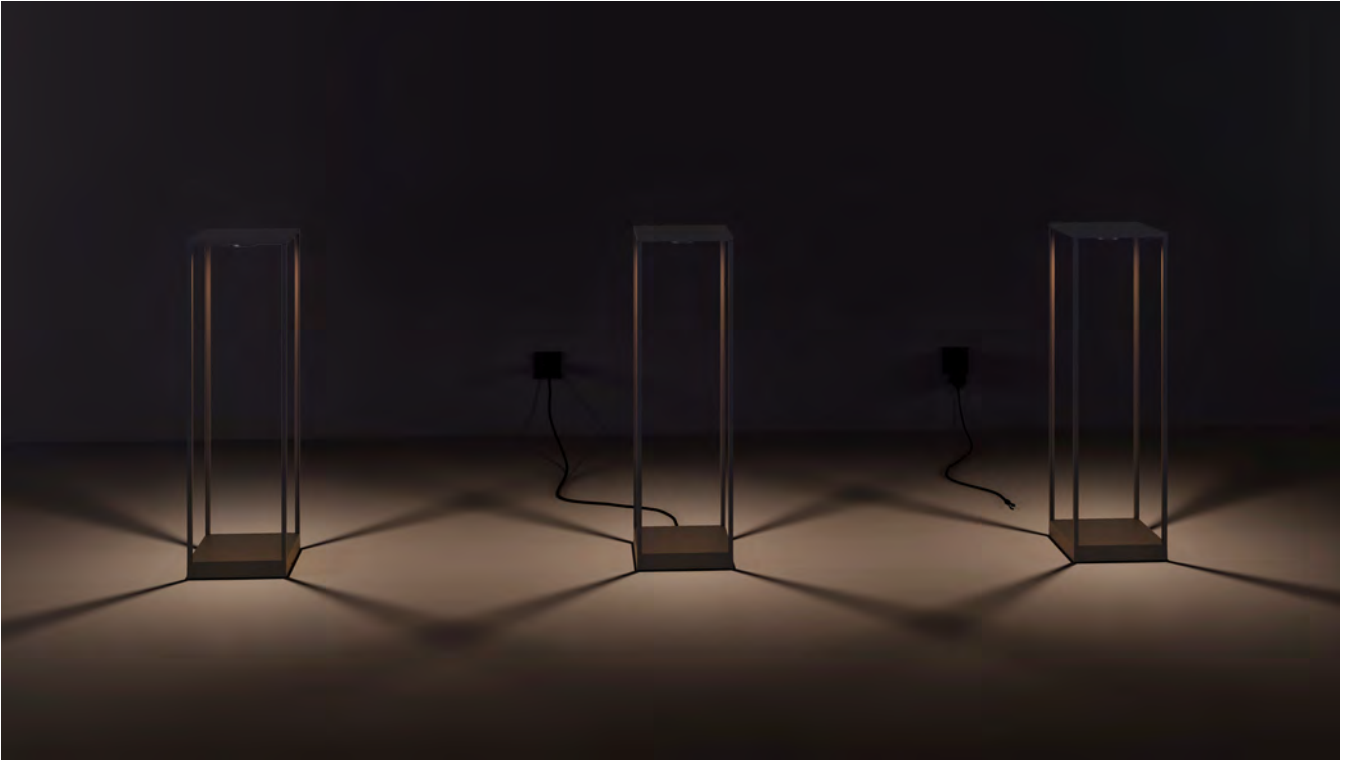

Three power supply options:
Fixed, portable with battery and portable
with cable and plug.

Trois options d'alimentation:
Fixe, portable avec batterie et portable
avec câble et prise.

Lineal Light Systems

Systemes d'éclairage linéaires

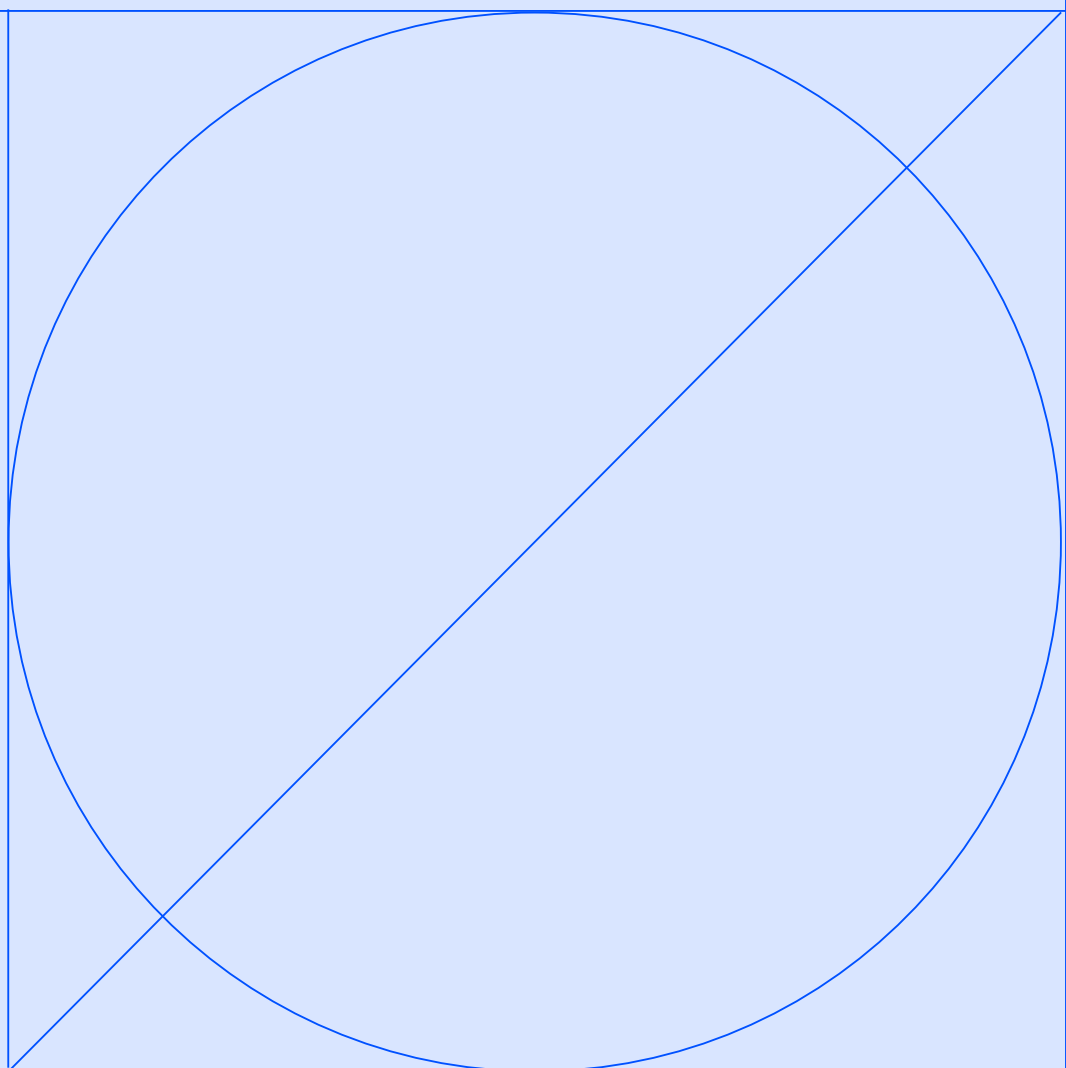
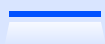

Taglio

478

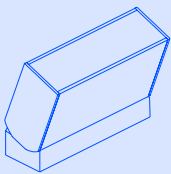

Vercle

496

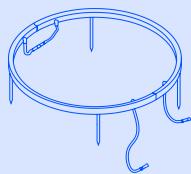

Asai

504

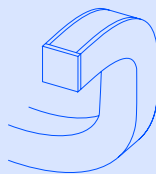

Mex

508

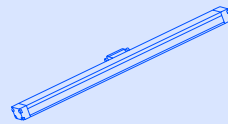

Convert

513

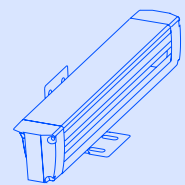

Cube Linear

518

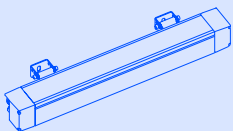

Taglio System

Designed by LedsC4 Architectural



+ Taglio



IP66/IP67 linear lighting integrated into the architecture

L'éclairage linéaire IP66/IP67 intégré à l'architecture

This collection features profiles and modules designed to create limitless compositions of linear lighting for surface-mounted, recessed or pendant installations. The Taglio System introduces a high level of aesthetics to projects and offers extensive lighting flexibility for both outdoor and indoor architectural spaces that demand a high degree of modularity, as well as robust IP and IK protection.

La collection Taglio System se compose de profilés et de modules qui permettent de créer des compositions infinies d'éclairage linéaire pour des installations en surface, encastrées ou suspendues. Taglio System confère un haut niveau esthétique au projet et une grande flexibilité d'éclairage aux espaces architecturaux intérieurs ou extérieurs qui nécessitent beaucoup de modularité, ainsi qu'une protection IP et IK élevée.

14



34



DL



E3



J6



Z5



60





Profiles Profils

Surface Fix



Surface Adjustable ($\pm 20^\circ$)

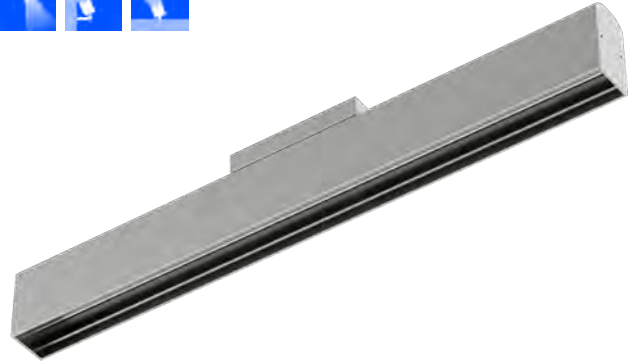

Accessories / Accessoires

Vertical joint
Rotule
verticale



Horizontal joint
Rotule
latérale



Fixed cables
Câbles
fixes



Stake
Piquet



Plaster bracket
Support
placoplâtre



Accessories / Accessoires

Extension arm
Bras de rallonge



Surface Wall

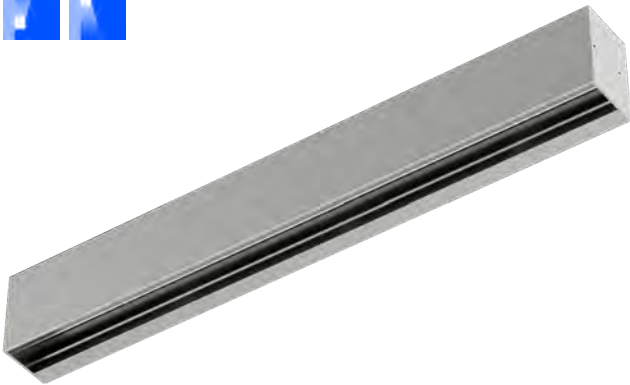

Surface Recessed

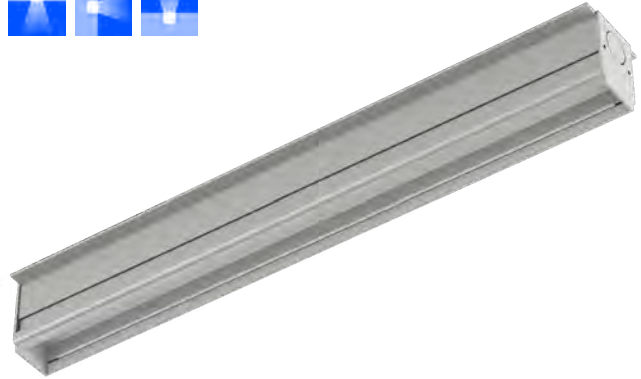

Sizes / Tailles



Opal



Optics



Spot



Covers



Taglio System configurator Configurateur Taglio System

Infinite configuration options in a quick and easy way thanks to our online configurator.

Une infinité d'options de configuration de manière simple et rapide grâce à notre configurateur en ligne.



tagliosystem.ledsc4.com





Installation options

Options d'installation

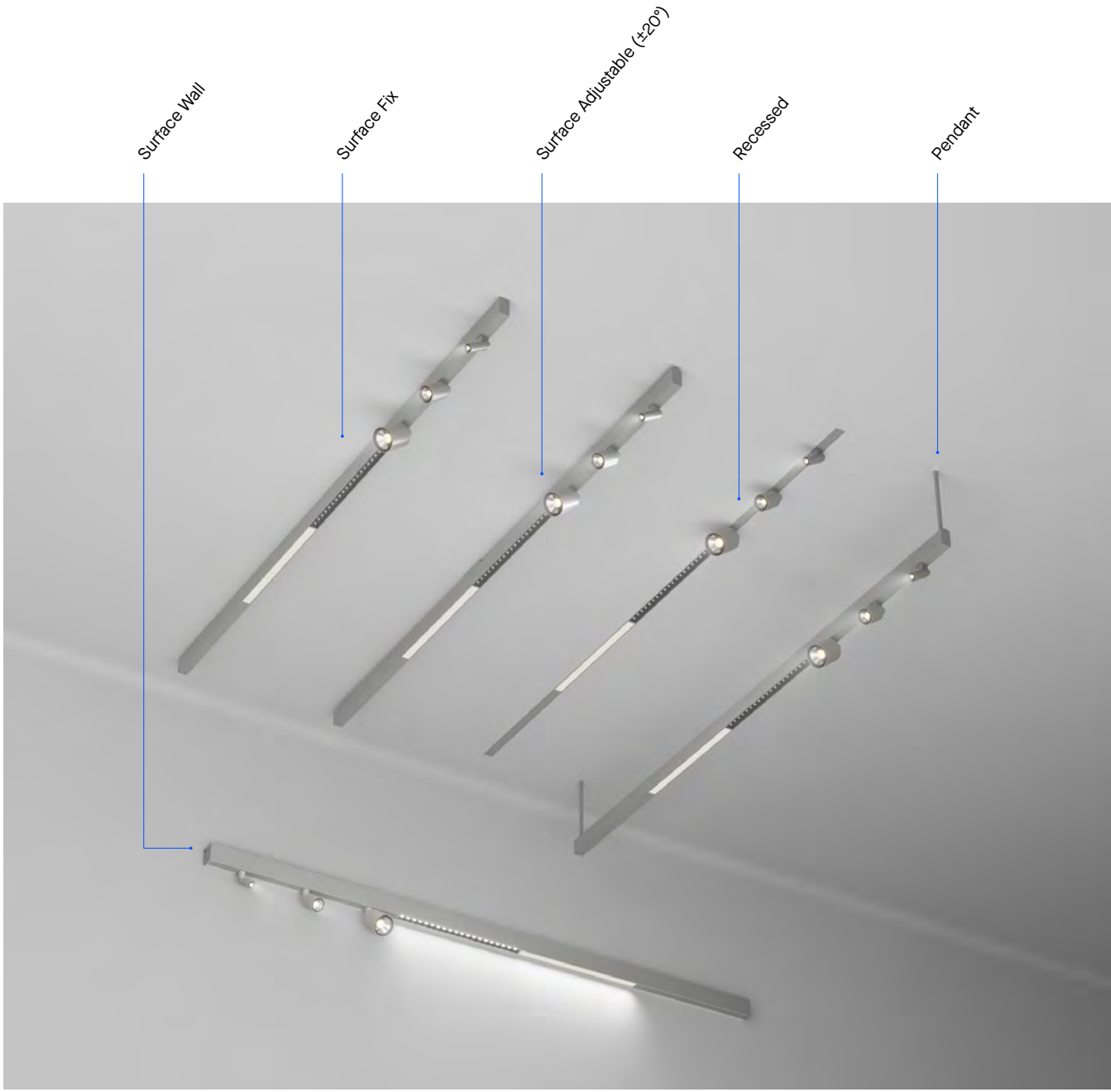

Individual installation or creation
of limitless compositions
Installation individuelle ou
création de compositions infinies

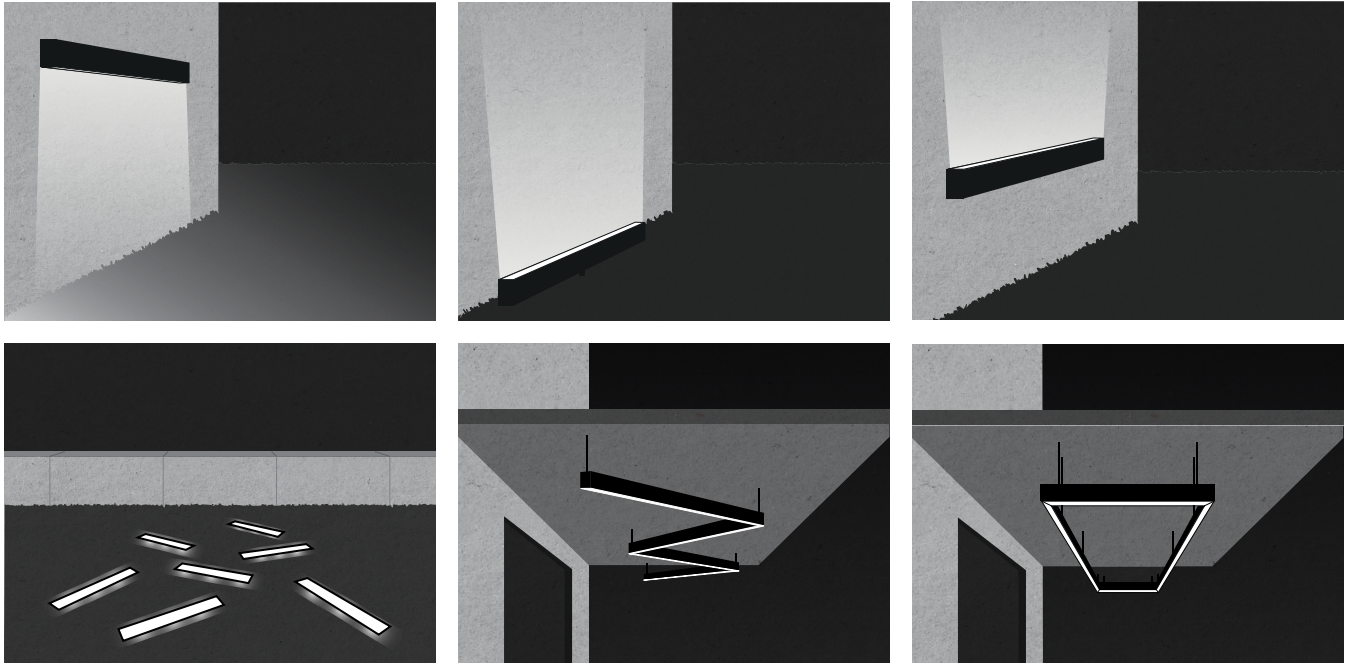

Dual switch-on with independent control
Allumage double avec réglage
indépendant

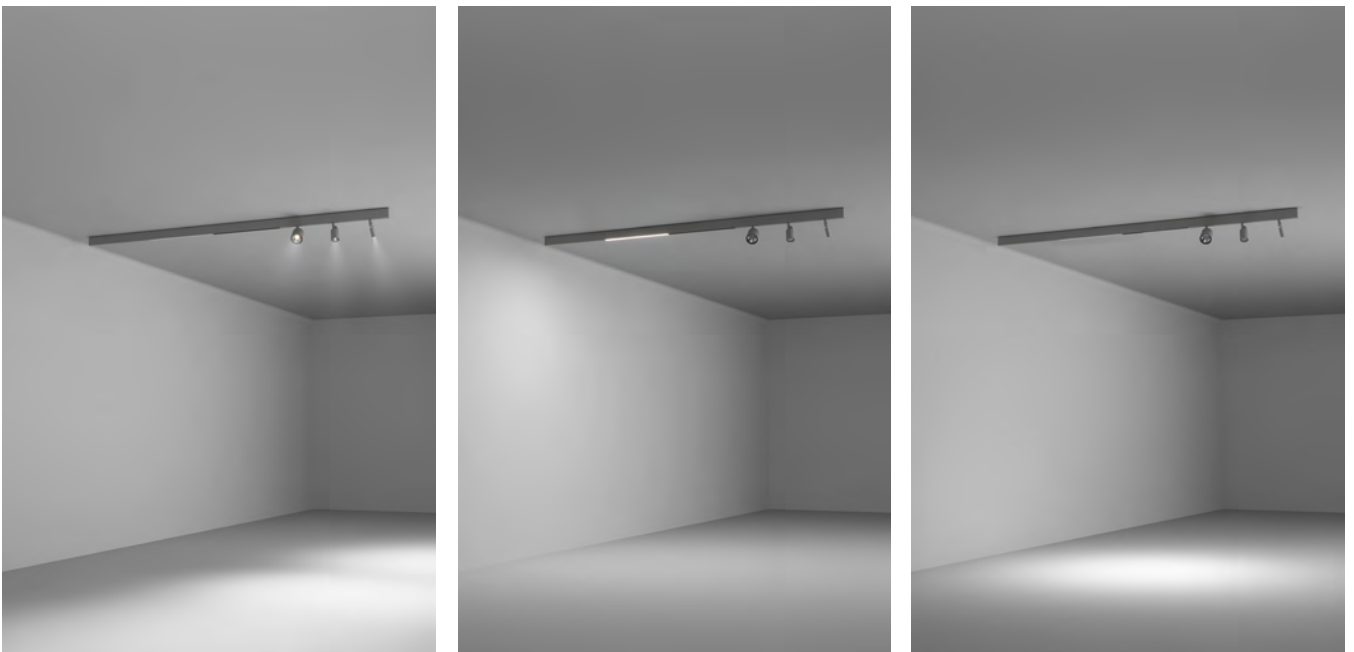



Illumination types

Types d'éclairage



General lighting - Opal
Éclairage général - Opal



Focused lighting - Optics
Éclairage focalisé - Optics



Accent lighting - Spotlights
Éclairage d'accentuation - Projecteurs



Easy to install
Facile à installer

Maximum protection.
Taglio System complies with
IP66/67 standards
Protection maximale.
Le système Taglio est conforme
aux normes IP66/67



Taglio System

Profiles

OUTDOOR

Taglio Profile Surface Fix

BODY MAT	50000h	SEA SIDE
AL	L80 B20	SUITABLE



 Z5* 14* 34* 60* DL* E3* J6*

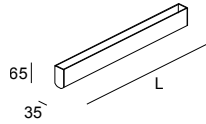

mm (L)	Code
500	71-E572 Z5
1000	71-E573 14
1500	71-E676 34
2000	71-E574 - 60 - 00
2500	71-E677 DL
3000	71-E575 E3
	J6



Fixing accessories Accessoires de fixation



Vertical swivel
Rotule verticale

Z5 ● *	71-E639-Z5-00	DL ● *	71-E639-DL-00
14 ○ *	71-E639-14-00	E3 ● *	71-E639-E3-00
34 ● *	71-E639-34-00	J6 ● *	71-E639-J6-00
60 ● *	71-E639-60-00		



Horizontal swivel
Rotule latérale

Z5 ● *	71-E638-Z5-00	DL ● *	71-E638-DL-00
14 ○ *	71-E638-14-00	J6 ● *	71-E638-J6-00
34 ● *	71-E638-34-00	E3 ● *	71-E638-E3-00
60 ● *	71-E638-60-00		



Rods for pendant 500 mm (x2)
Tiges pour suspension 500 mm (2 u.)

Z5 ● *	71-E647-Z5-00	DL ● *	71-E647-DL-00
14 ○ *	71-E647-14-00	E3 ● *	71-E647-E3-00
34 ● *	71-E647-34-00	J6 ● *	71-E647-J6-00
60 ● *	71-E647-60-00		



Rods for pendant 1000 mm (x2)
Tiges pour suspension 1000 mm (2 u.)

Z5 ● *	71-E648-Z5-00	DL ● *	71-E648-DL-00
14 ○ *	71-E648-14-00	E3 ● *	71-E648-E3-00
34 ● *	71-E648-34-00	J6 ● *	71-E648-J6-00
60 ● *	71-E648-60-00		



Stake 235mm
Piquet 235mm

71-9997-05-05



Stake 302mm
Piquet 302mm

71-9998-05-05



Plaster bracket (x3)
Support placoplâtre (3 u.)

71-E642-00-00

LINEAL LIGHT SYSTEMS | SYSTÈMES D'ÉCLAIRAGE LINÉAIRES

Taglio Profile
Surface Adjustable
(±20°)

BODY MAT	50000h	SEA SIDE	↕
AL	L80 B20	SUITABLE	20°

● ○ ● ● ● ● ●
Z5* 14* 34* 60* DL* E3* J6*

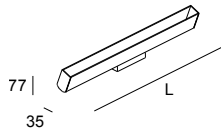

mm (L)	Code
500	71-E577 Z5
1000	71-E578 14
1500	71-E678 34
2000	71-E579 - 60 - 00
2500	71-E679 DL
3000	71-E580 E3
	J6

Fixing accessories
Accessoires de fixation



Extension arm 70mm
Bras de rallonge 70mm

Z5 ● *	71-E359-Z5-00	DL ● *	71-E359-DL-00
14 ○ *	71-E359-14-00	E3 ● *	71-E359-E3-00
34 ● *	71-E359-34-00	J6 ● *	71-E359-J6-00
60 ● *	71-E359-60-00		



Extension arm 140mm
Bras de rallonge 140mm

Z5 ● *	71-E360-Z5-00	DL ● *	71-E360-DL-00
14 ○ *	71-E360-14-00	E3 ● *	71-E360-E3-00
34 ● *	71-E360-34-00	J6 ● *	71-E360-J6-00
60 ● *	71-E360-60-00		

Taglio Profile
Surface Wall

BODY MAT	50000h	SEA SIDE
AL	L80 B20	SUITABLE

● ○ ● ● ● ● ●
Z5* 14* 34* 60* DL* E3* J6*

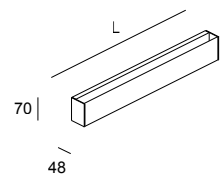

mm (L)	Code
500	71-E582 Z5
1000	71-E583 14
1500	71-E680 34
2000	71-E584 - 60 - 00
2500	71-E681 DL
3000	71-E585 E3
	J6

Taglio Profile
Recessed

BODY MAT
AL

50000h
L80 B20

SEA SIDE
SUITABLE



54

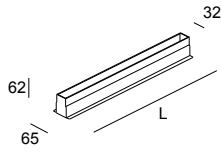
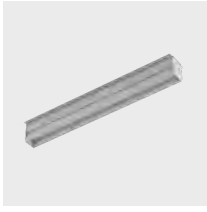

OUTDOOR



mm (L)	Code
500	71-E047
1000	71-E043
1500	71-E682
2000	71-E586 - 54 - 00
2500	71-E683
3000	71-E587



Fixing accessories
Accessoires de fixation

	Recess case Boîtier d'encastrement	Included
	Cover to stop cement from entering during installation Cache permettant d'éviter la pénétration de ciment en cours d'installation	Included

Repair accessories
Accessoires de réparation

	Module extraction accessory Accessoire d'extraction du module	71-E663-00-00
-------------------------------------------------------------------------------------	------------------------------------------------------------------	---------------

LINEAL LIGHT SYSTEMS | SYSTÈMES D'ÉCLAIRAGE LINÉAIRES

Taglio System

Modules

Taglio Opal 500mm

BODY MAT	DIF MAT	50000h		3	IP	IK		SEA SIDE			PWM
AL	PMMA	L80 B20		MacAdam	66-67	10		SUITABLE			

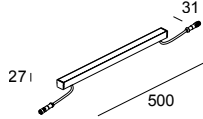

LED						24VDC
K	CRI	W	Real Lm	Code		
2700	80	7.4	485	71-E243	- M3 -	CK
3000	80	7.4	505	71-E243		CL
4000	80	7.4	541	71-E243		CM
RGB	80	8.4	460	71-E244		OO

Taglio Opal 1000mm

BODY MAT	DIF MAT	50000h		3	IP	IK		SEA SIDE			PWM
AL	PMMA	L80 B20		MacAdam	66-67	10		SUITABLE			

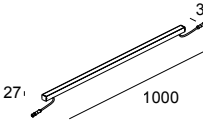

LED						24VDC
K	CRI	W	Real Lm	Code		
2700	80	14.7	1050	71-E037	- M3 -	CK
3000	80	14.7	1092	71-E037		CL
4000	80	14.7	1169	71-E037		CM
RGB	80	15.4	460	71-E038		OO

Taglio Optics 500mm

BODY MAT	DIF MAT	50000h		3	IP	IK		SEA SIDE			PWM
AL	GLA	L80 B20		MacAdam	66-67	06		SUITABLE			

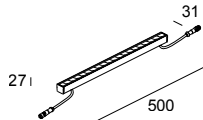

LED						24VDC
K	CRI	W	Real Lm	Code		
2700	80	19	1182	71-E163	- 37 -	CK
3000	80	19	1182	71-E163		CL
4000	80	19	1182	71-E163		CM
RGB	80	20	460	71-E245		OO

Taglio Spot Small

IP	IK	UGR		SEA SIDE SUITABLE				
66	04	<16					LED	PWM

Code example / Exemple d'élaboration d'une référence: **BI11-P3V8S3BBZ5**

Model		W	K	CRI	Optics	Lm	Source	Finishes
BI11 - 	P3V8	2.5	2700	80	S3 19°	94	BB 24VDC	Z5*
	P3W8	2.5	3000	80	M3 32°	97		14*
	P3X8	2.5	4000	80	F2 51°	87		34*
					T3 13° Honeycomb incl.	51		60*
					K3 27° Honeycomb incl.	56		DL*
					N2 38° Honeycomb incl.	33		E3*
								J6*

Taglio Spot Medium

IP	IK	UGR		SEA SIDE SUITABLE				
66	10	<16					LED	PWM

Code example / Exemple d'élaboration d'une référence: **BI12-P6V9S1BBZ5**

Model		W	K	CRI	Optics	Lm	Source	Finishes
BI12 - 	P6V9	6	2700	90	S1 9°	204	BB 24VDC	Z5*
	P6W9	6	3000	90	T1 7° Honeycomb incl.	186		14*
	P6X9	6	4000	90				34*
	P8V9	7.9	2700	90	S2 17°	519	BB 24VDC	60*
	P8W9	7.9	3000	90	M2 27°	452		DL*
	P8X9	7.9	4000	90	F1 50°	423		E3*
					T2 14° Honeycomb incl.	347		J6*
					K2 27° Honeycomb incl.	383		
					N1 40° Honeycomb incl.	351		

Taglio Spot Big

IP	IK	UGR		SEA SIDE SUITABLE				
66	10	<16					LED	PWM

Code example / Exemple d'élaboration d'une référence: **BI13-P14V9S3BBZ5**

Model		W	K	CRI	Optics	Lm	Source	Finishes
BI13 - 	P14V9	13.8	2700	90	S3 16°	1086	BB 24VDC	Z5*
	P14W9	13.8	3000	90	M2 28°	1076		14*
	P14X9	13.8	4000	90	F2 51°	1120		34*
					T3 16° Honeycomb incl.	870		60*
					K2 25° Honeycomb incl.	792		DL*
					N2 42° Honeycomb incl.	695		E3*
								J6*

Taglio Covers

BODY MAT	50000h	SEA SIDE
AL	L80 B20	SUITABLE

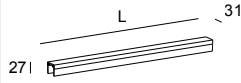
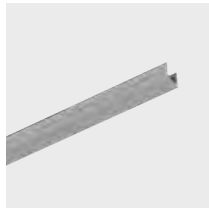
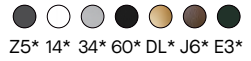

mm (L)	Code
250	Z5
500	71-E614 14
1000	71-E615 34
2000	71-E616 - 60 - 00
	71-E617 DL
	J6
	E3

Power supplies
Sources d'alimentation

Modules with integrated power supply unit (suitable for any profile)
Modules avec bloc d'alimentation intégré (adaptés à tous les profils)

	ON-OFF IP67	Max. 30W	Z5 ● * 71-E618-Z5-OU	DL ● * 71-E618-DL-OU	60 ● * 71-E618-60-OU	E3 ● * 71-E618-E3-OU
			J6 ● * 71-E618-J6-OU	14 ○ * 71-E618-14-OU	34 ● * 71-E618-34-OU	
		Max. 100W	Z5 ● * 71-E619-Z5-OU	DL ● * 71-E619-DL-OU	60 ● * 71-E619-60-OU	E3 ● * 71-E619-E3-OU
			J6 ● * 71-E619-J6-OU	14 ○ * 71-E619-14-OU	34 ● * 71-E619-34-OU	

Ceiling rose with integrated power supply (suggested for suspended version)
Flamme avec alimentation intégrée (suggérée pour la version suspendue)











	ON-OFF IP67	Max. 30W	Z5 ● * 71-E640-Z5-OU	DL ● * 71-E640-DL-OU	60 ● * 71-E640-60-OU	E3 ● * 71-E640-E3-OU
			J6 ● * 71-E640-J6-OU	14 ○ * 71-E640-14-OU	34 ● * 71-E640-34-OU	
		Max. 100W	Z5 ● * 71-E641-Z5-OU	DL ● * 71-E641-DL-OU	60 ● * 71-E641-60-OU	E3 ● * 71-E641-E3-OU
			J6 ● * 71-E641-J6-OU	14 ○ * 71-E641-14-OU	34 ● * 71-E641-34-OU	

Remote power supply
Alimentation à distance

P. 985

	ON-OFF IP67	Max. 30W	71-B644-00-00		DALI2 IP67	Max. 30W	71-B655-00-00
		Max. 160W	71-B647-00-00		Max. 160W	71-B656-00-00	
		Max. 240W	71-B648-00-00		Max. 240W	71-B675-00-00	

* Please contact our sales team for conditions and delivery times.
* Consultez notre équipe commerciale pour connaître les conditions et les délais de livraison.

	Taglio modules Opal/Optics	Taglio modules Opal/Optics (RGB)
Connection accessories Accessoires de connexion		
 Cable with waterproof tongue and groove connectors (1 m) Câble avec connecteurs étanches mâle-femelle (1 m)	71-E034-00-00	-
 Cable with waterproof tongue and groove connectors (5 m) Câble avec connecteurs étanches mâle-femelle (5 m)	71-E004-00-00	-
 RGB cable with waterproof tongue and groove connectors (1 m) Câble RGB avec connecteurs étanches mâle-femelle (1 m)	-	71-E071-00-00
 RGB cable with waterproof tongue and groove connectors (5 m) Câble RGB avec connecteurs étanches mâle-femelle (5 m)	-	71-E005-00-00
 Waterproof connectors Connecteurs étanches	Included	Included
 IP67 connector (1 input + 1 output) Ø 5.5-7.5 mm, 3 poles Connecteur IP67 (1 entrée + 1 sortie) Ø 5,5 - 7,5 mm, 3 pôles	71-E510-00-00	-
 IP67 connector (1 input + 2 outputs) Ø 5.5-7.5 mm, 3 poles Connecteur IP67 (1 entrée + 2 sorties) Ø 5,5 - 7,5 mm, 3 pôles	71-E511-00-00	-
 IP68 connector (1 input + 1 output) Ø 5.5-11.5 mm, 4 poles Connecteur IP68 (1 entrée + 1 sortie) Ø 5,5 - 11,5 mm, 4 pôles	71-E512-00-00	71-E512-00-00
 IP68 connector (1 input + 2 outputs) Ø 5.5-11.5 mm, 3 poles Connecteur IP68 (1 entrée + 2 sorties) Ø 5,5 - 11,5 mm, 3 pôles	71-E513-00-00	-
 IP68 anti-condensation connector (1 input + 1 output) Ø 5.5-12 mm, 4 poles Connecteur anticondensation IP68 (1 entrée + 1 sortie) Ø 5,5 - 12 mm, 4 pôles	71-E112-00-00	71-E112-00-00
 IP68 anti-condensation connector (1 input + 3 outputs) Ø 5.5-12 mm, 4 poles Connecteur anticondensation IP68 (1 entrée + 3 sorties) Ø 5,5 - 12 mm, 4 pôles	71-E122-00-00	71-E122-00-00
 Waterproof cable Câble imperméable	Included	Included

Connective controllers

Contrôleurs connectés

P. 969



Consult the available control systems / Consultez les systèmes de contrôle disponibles:

DALI2 / DALI2

Bluetooth wireless / Sans fil Bluetooth

DMX / DMX

Autonomous / Autonome

Vercle

Designed by Artec Studio



+ Vercle

Minimalist lighting for vegetation Éclairage minimaliste pour la végétation

The Vercle collection is designed to give true prominence to the vegetation and create purer and more relaxed spaces between the landscape and people. This minimalist and invisible collection allows you to illuminate the outlines of trees and all kinds of plants and garden elements.

La collection Vercle est conçue pour donner une véritable place à la végétation et créer des espaces plus purs et plus détendus entre le paysage et les personnes. Une collection minimaliste et invisible qui permet d'éclairer le contour des arbres et toutes sortes d'éléments végétaux.



Circular

400 mm

650 mm

1200 mm



Linear

500 mm

1970 mm







Designed to be invisible yet
powerful
Conçu pour être invisible et fournir
un éclairage puissant

The outer part of the profile is higher than the lower one to maximise visual comfort.

Partie extérieure du profilé plus élevée que la partie inférieure pour un maximum de confort visuel.

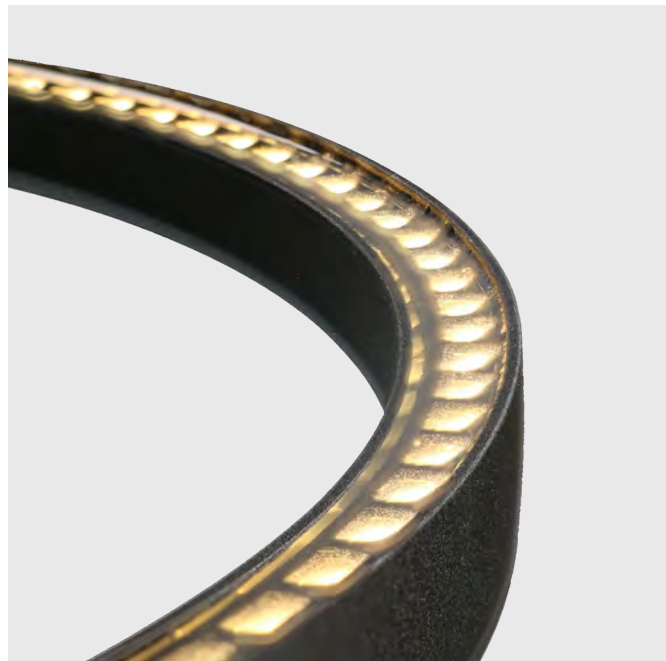

Considered and compact design
Design soigné et compact



Only 17 mm high.
Seulement 17 mm de hauteur.



Only 10 mm wide.
Seulement 10 mm de largeur.

Adaptable light for changing scenes

Lumière adaptable à chaque scène

Vercle's total light control allows you to devise different scenes that can be adapted to the architecture in the space and to each moment.
Le contrôle total de la lumière de Vercle permet de créer différentes scènes qui peuvent s'adapter à l'architecture de l'espace et de chaque instant.

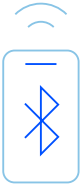

Compositions Compositions

Vercle allows you to create your own compositions by combining the circular and linear model.

Vercle permet de créer des compositions propres en combinant le modèle circulaire et le modèle linéaire.



Composition with Vercle 650 mm circular and 1970 mm linear.
Composition avec Vercle circulaire de 650 mm et linéaire de 1970 mm.

Installations Installations

Spikes of different heights are included for mounting in soft ground.

Des piquets de différentes hauteurs sont inclus pour la fixation sur terrains meubles.

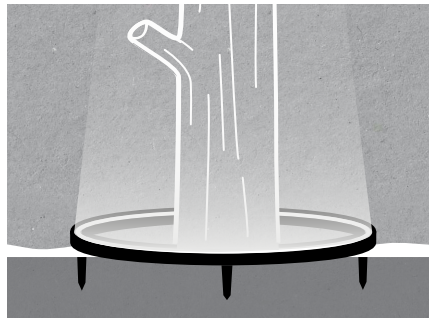

Flat surface
Surface plate

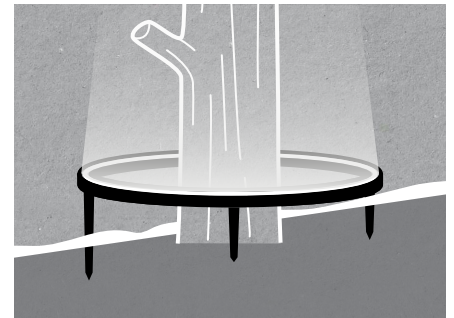

Tilted surface
Surface inclinée

Includes wiring with quick and sealed connection for easy and safe installation.

Comprend le câblage avec connexion rapide et étanche pour une installation facile et sûre.

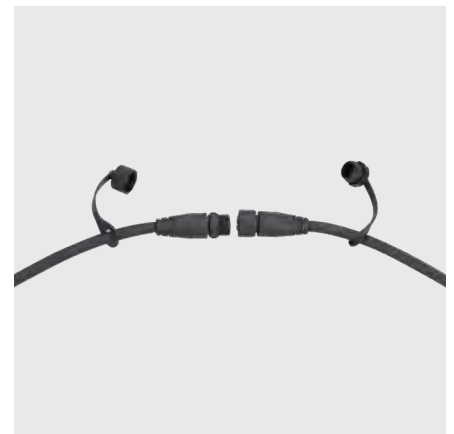
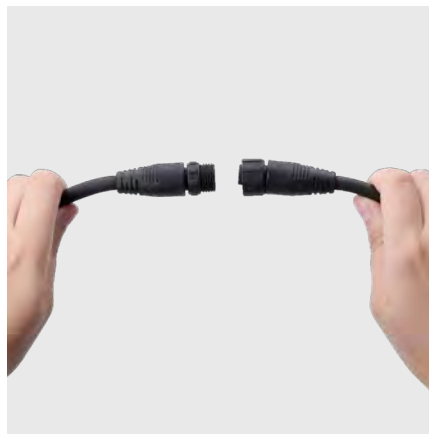

**Vercle Round
Ø400mm**

BODY MAT
AL



50000h
L80 B20

3
MacAdam

IP
65

IK
10

UGR
<16



●
05

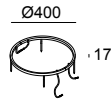
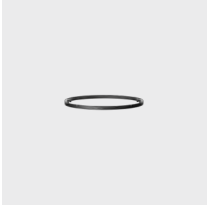

LED					24VDC
K	CRI	W	Real Lm	Code	
3000	80	26	589	55-E117 - 05 - CL	

**Vercle Round
Ø650mm**

BODY MAT
AL



50000h
L80 B20

3
MacAdam

IP
65

IK
10

UGR
<10



●
05

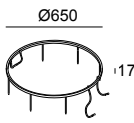
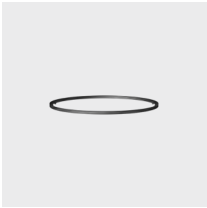

LED					24VDC
K	CRI	W	Real Lm	Code	
3000	80	43.9	1001	55-E118 - 05 - CL	

**Vercle Round
Ø1200mm**

BODY MAT
AL



50000h
L80 B20

3
MacAdam

IP
65

IK
10

UGR
<10



●
05

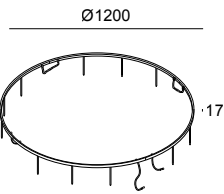
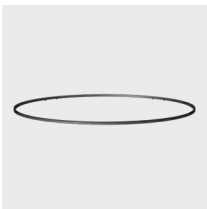

LED					24VDC
K	CRI	W	Real Lm	Code	
3000	80	64.8	1567	55-E021 - 05 - CL	

**Vercle Lineal
500mm**

BODY MAT
AL



50000h
L80 B20

IP
65

IK
10

UGR
<19



●
05

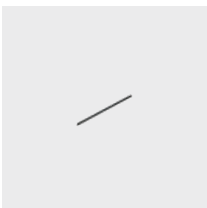

LED					24VDC
K	CRI	W	Real Lm	Code	
3000	80	10.3	211	55-E119 - 05 - CL	

**Vercle Lineal
1970mm**

BODY MAT
AL



50000h
L80 B20

IP
65

IK
10

UGR
<19



●
05

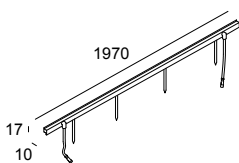
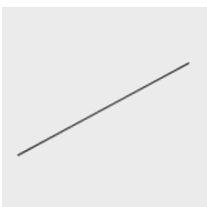



LED					24VDC
K	CRI	W	Real Lm	Code	
3000	80	42.5	869	55-E120 - 05 - CL	

Power supplies
Sources d'alimentation

P. 985

OUTDOOR





LINEAL LIGHT SYSTEMS | SYSTÈMES D'ÉCLAIRAGE LINÉAIRES

	ON-OFF IP20	Max. 20W	71-B650-00-00		DALI2 IP20	Max. 60W	71-B652-00-00	
		Max. 30W	71-B640-00-00			Max. 150W	71-B653-00-00	
		Max. 100W	71-B641-00-00			Max. 250W	71-B654-00-00	
		Max. 150W	71-B642-00-00			DALI2 IP67	Max. 60W	71-B655-00-00
		Max. 250W	71-B643-00-00				Max. 160W	71-B656-00-00
	ON-OFF IP67	Max. 30W	71-B644-00-00			Max. 240W	71-B675-00-00	
		Max. 60W	71-B645-00-00					
		Max. 100W	71-B646-00-00					
		Max. 160W	71-B647-00-00					
		Max. 240W	71-B648-00-00					

Fixing accessories
Accessoires de fixation

	Spiked post Piquet	Included
-------------------------------------------------------------------------------------	-----------------------	----------

Connection accessories
Accessoires de connexion

	Cable with waterproof tongue and groove connectors (5 m) Câble avec connecteurs étanches mâle-femelle (5 m)	71-E118-05-05
	Waterproof connectors Connecteurs étanches	Included
	IP68 anti-condensation connector (1 input + 1 output) Ø 5.5–12 mm, 4 poles Connecteur anticondensation IP68 (1 entrée + 1 sortie) Ø 5,5 - 12 mm, 4 pôles	71-E112-00-00
	IP68 anti-condensation connector (1 input + 3 outputs) Ø 5.5–12 mm, 4 poles Connecteur anticondensation IP68 (1 entrée + 3 sorties) Ø 5,5 - 12 mm, 4 pôles	71-E122-00-00

503



+ Asai 3D



16 mm



8 mm

Asai 3D adapts easily to any contour and environment, creating continuous and infinite effects. It offers excellent flexibility and resistance thanks to its extruded polyurethane casing.

Asai 3D s'adapte facilement à tout contour et environnement, créant des effets continus et infinis. Il affiche une flexibilité et une résistance extraordinaires, grâce à son corps extrudé en polyuréthane.



Asai 3D allows infinite curves thanks to its flexibility

Asai 3D permet des courbes infinies grâce à sa flexibilité.

IP68 connectors for fast connection
Connecteurs IP68 pour une connexion rapide





Asai 3D allows infinite curves thanks to its flexibility
Asai 3D permet des courbes infinies grâce à sa flexibilité.

**Asai 3D 8mm
1000mm**

BODY MAT
PVC

DIF MAT
PVC



50000h
L80 B20

IP
67

IK
10

PWM

8 m

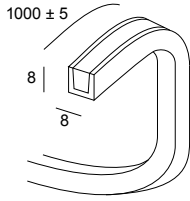

LED					24VDC
K	CRI	W	Real Lm	Code	
3000	90	4.6	331	91-A035 - 00 - 00	
4000	90	4.6	367	91-A036 - 00 - 00	

**Asai 3D 8mm
5000m**

BODY MAT
PVC

DIF MAT
PVC



50000h
L80 B20

IP
67

IK
10

PWM

8 m

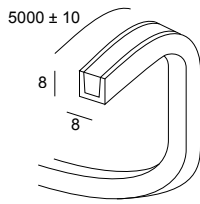

LED					24VDC
K	CRI	W	Real Lm	Code	
3000	90	23	1656	91-A038 - 00 - 00	
4000	90	23	1656	91-A039 - 00 - 00	

**Asai 3D 16mm
1000m**

BODY MAT
PVC

DIF MAT
PVC



50000h
L80 B20

IP
67

IK
10

PWM

8 m

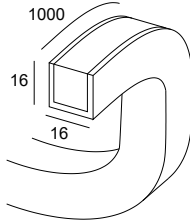

LED					24VDC
K	CRI	W	Real Lm	Code	
3000	80	14.4	441	91-A000 - 00 - 00	
4000	80	14.4	498	91-A002 - 00 - 00	
RGB		14.4	194	91-A004 - 00 - 00	

**Asai 3D 16mm
8000m**

BODY MAT
PVC

DIF MAT
PVC



50000h
L80 B20

IP
67

IK
10

PWM

8 m

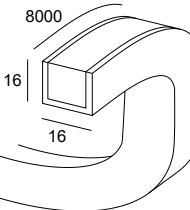

LED					24VDC
K	CRI	W	Real Lm	Code	
3000	80	115.2	3529	91-A001 - 00 - 00	
4000	80	115.2	3988	91-A003 - 00 - 00	
RGB		115.2	1552	91-A005 - 00 - 00	

Asai 3D 8mm



Asai 3D 16mm



Asai 3D RGB

**Fixing accessories****Accessoires de fixation**

	Clips (20u.) Clips (20 u.)	71-B456-00-00	71-6607-00-00	71-6607-00-00
	2m flexible profile Profilé 2 m flexible	71-B457-00-00	71-7698-00-00	71-7698-00-00
	2m rigid profile Profilé 2 m rigide	71-B458-00-00	71-6608-00-00	71-6608-00-00

Connection accessories**Accessoires de connexion**

	Cable with waterproof tongue and groove connectors (1 m) Câble avec connecteurs étanches mâle-femelle (1 m)	71-B679-00-00	71-E034-00-00	-
	Cable with waterproof tongue and groove connectors (5 m) Câble avec connecteurs étanches mâle-femelle (5 m)	71-B680-00-00	71-E004-00-00	-
	RBG cable with waterproof tongue and groove connectors (1 m) Câble RGB avec connecteurs étanches mâle-femelle (1 m)	-	-	71-E071-00-00
	RBG cable with waterproof tongue and groove connectors (5 m) Câble RGB avec connecteurs étanches mâle-femelle (5 m)	-	-	71-E005-00-00

Power supplies**Sources d'alimentation**

P. 988

Connective controllers**Contrôleurs connectés**

P. 969

**Consult the available control systems / Consultez les systèmes de contrôle disponibles:**

DALI2 / DALI2

Bluetooth wireless / Sans fil Bluetooth

Autonomous / Autonome

Mex

Designed by LedsC4 Architectural



+ Mex



Compact solution for low-rise façades Solution compacte pour les façades de faible hauteur

Discreet and elegant, Mex is a wall-bathing luminaire that seeks to illuminate without being seen. The homogeneity and Dark Light effect of this collection make the visual perception on the illuminated wall a real treat for the senses. Discret et élégant, Mex est un lèche-mur qui cherche à éclairer sans être vu. L'homogénéité et l'effet Dark Light de cette collection font de la perception visuelle sur le mur éclairé un cadeau pour les sens.

Surface

330 mm

1000 mm

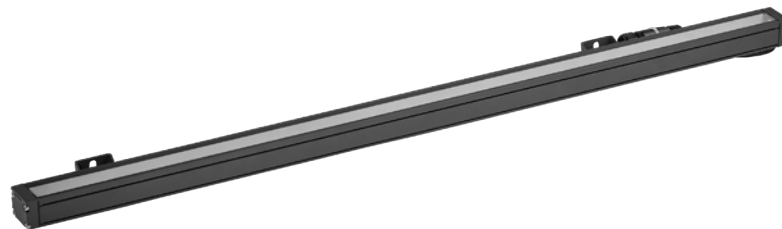

Recessed

334 mm

1004 mm

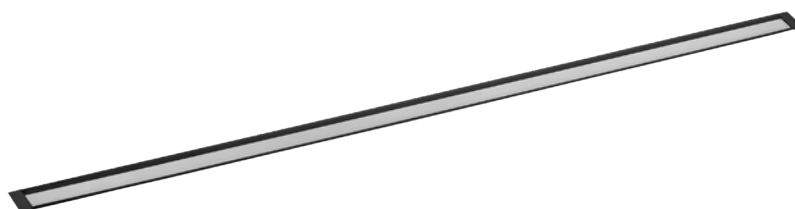

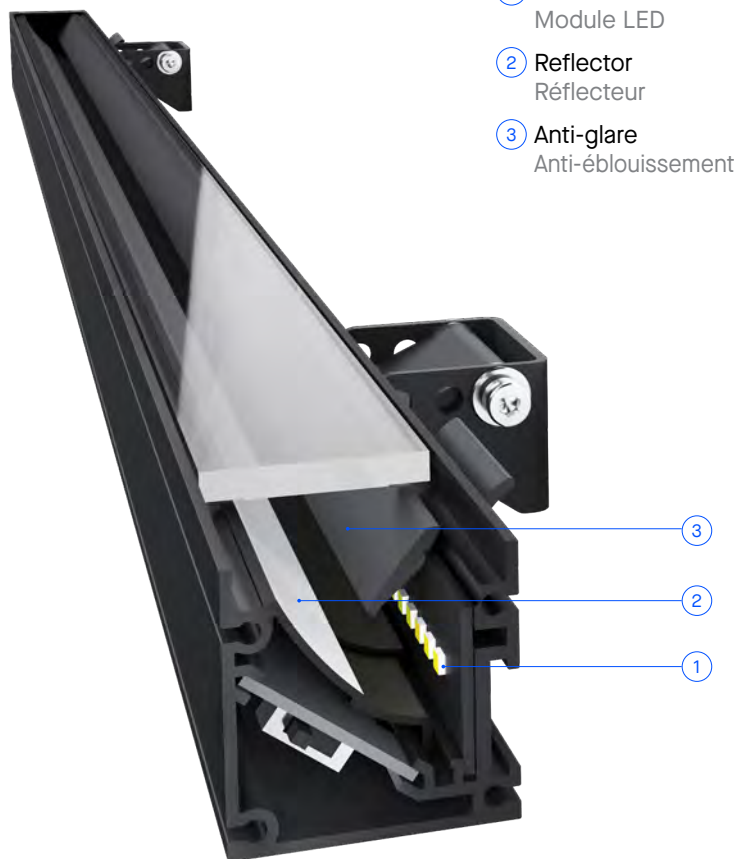

① LED module
Module LED

② Reflector
Réflecteur

③ Anti-glare
Anti-éblouissement

The LEDs are hidden inside the profile and light is emitted by reflection without generating glare.
Les LED sont cachées à l'intérieur du profilé et la lumière est émise par réflexion sans générer d'éblouissement.

Built-in CCT switch that allows you to change the colour temperature according to the needs of the space.

Switch (interrupteur) CCT intégré qui permet de modifier la température de couleur en fonction des besoins de l'espace.



Lenses Optiques

Includes wiring with quick and sealed connection for easy and safe installation.

Comprend le câblage avec connexion rapide et étanche pour une installation facile et sûre.

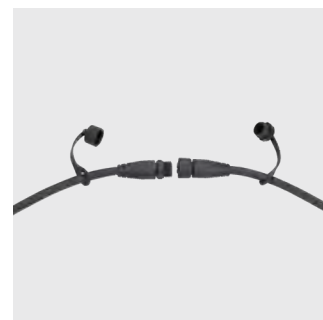
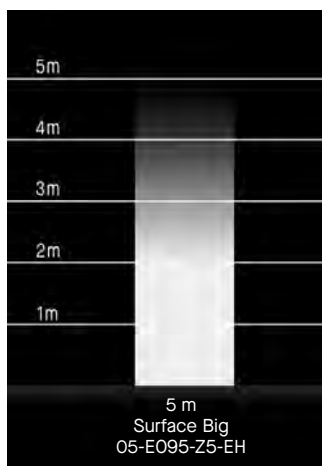

BODY MAT	DIF MAT		50000h
AL	GLA		L80 B20

Mex Surface 330mm

IP	IK	UGR		SWITCH CCT	SEA SIDE				
65	09	<10		2700-3200-4000	SUITABLE	PWM	+15° -90°		

Z5



LED						24VDC
K	CRI	W	Real Lm	Optics	Code	
2700-3200-4000	80	9.8	314	50°	05-E163 - Z5 - EH	

The indicated flux corresponds to the core temperature.
Le flux indiqué correspond à la température centrale.

Mex Surface 1000mm

IP	IK	UGR		SWITCH CCT	SEA SIDE				
65	09	<10		2700-3200-4000	SUITABLE	PWM	+15° -90°		

Z5

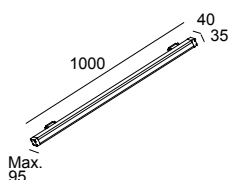

LED						24VDC
K	CRI	W	Real Lm	Optics	Code	
2700-3200-4000	80	24	769	50°	05-E164 - Z5 - EH	

The indicated flux corresponds to the core temperature.
Le flux indiqué correspond à la température centrale.

Mex Surface 330mm



Mex Surface 1000mm



Connection accessories Accessoires de connexion



Sealed IP67 connectors
Connecteurs étanches IP67

Included

Included

Joint accessories Accessoires de raccord



Base for surface mounting
Socle à fixer en surface

Included

Included

Mex Recessed 334mm

IP 65-67	IK 09	UGR <10	250 Kg		SWITCH CCT 2700-3200-4000	SEA SIDE SUITABLE	PWM	+15° -90°		
-------------	----------	------------	--------	--	------------------------------	----------------------	-----	-----------	--	--

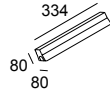

LED							24VDC
K	CRI	W	Real Lm	Optics	Code		
2700-3200-4000	80	9.8	314	50°	55-E114 - Z5 - EH		

The indicated flux corresponds to the core temperature.
Le flux indiqué correspond à la température centrale.

Z5

Mex Recessed 1004mm

IP 65-67	IK 09	UGR <10	250 Kg		SWITCH CCT 2700-3200-4000	SEA SIDE SUITABLE	PWM	+15° -90°		
-------------	----------	------------	--------	--	------------------------------	----------------------	-----	-----------	--	--

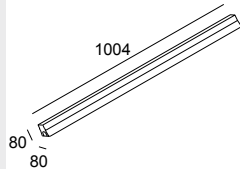

LED							24VDC
K	CRI	W	Real Lm	Optics	Code		
2700-3200-4000	80	24	769	50°	55-E115 - Z5 - EH		

The indicated flux corresponds to the core temperature.
Le flux indiqué correspond à la température centrale.

Z5

Mex Recessed 334m



Mex Recessed 1004mm



Fixing accessories Accessoires de fixation



Recess case
Boîtier d'encastrement

Included

Included

Connection accessories Accessoires de connexion



Sealed IP67 connectors
Connecteurs étanches IP67

Included

Included

Union accessories Accessoires d'union



Interlinking accessories
Accessoires d'enchaînement

Included

Included



Cover to stop cement from entering during installation
Cache permettant d'éviter la pénétration de ciment en cours d'installation

Included

Included

Connection accessories

Accessoires de connexion



Extension 1000 mm
Rallonge 1 000 mm

71-E437-05-05

Extension 5000 mm
Rallonge 5 000 mm

71-E427-05-05

Extension 10000 mm
Rallonge 10 000 mm

71-E552-05-05



Extension T
Rallonge en T

71-E557-05-05

Power supplies

P. 985

Sources d'alimentation



ON-OFF IP20 Max. 20W **71-B650-00-00**

Max. 30W **71-B640-00-00**

Max. 100W **71-B641-00-00**

Max. 150W **71-B642-00-00**

Max. 250W **71-B643-00-00**



DALI2 IP20 Max. 60W **71-B652-00-00**

Max. 150W **71-B653-00-00**

Max. 250W **71-B654-00-00**



DALI2 IP67 Max. 60W **71-B655-00-00**

Max. 160W **71-B656-00-00**

Max. 240W **71-B675-00-00**



ON-OFF IP67 Max. 30W **71-B644-00-00**

Max. 60W **71-B645-00-00**

Max. 100W **71-B646-00-00**

Max. 160W **71-B647-00-00**

Max. 240W **71-B648-00-00**

Connective controllers

P. 969

Contrôleurs connectés



Consult the available control systems / Consultez les systèmes de contrôle disponibles:

DALI2 / DALI2

Bluetooth wireless / Sans fil Bluetooth

DMX / DMX

Autonomous / Autonome

Convert

Essential
SOLUTION

Designed by LedsC4 Architectural

OUTDOOR

LINEAL LIGHT SYSTEMS | SYSTÈMES D'ÉCLAIRAGE LINÉAIRES



Lighting for medium-height façades Éclairage pour façades de hauteur moyenne

This luminaire offers even, spot-free lighting for medium-height façades.

Éclairage uniforme, sans aucun résidu gênant l'homogénéité lumineuse, sur les façades de hauteur moyenne.

Convert Surface

516

356 mm



○
54

984 mm



○
54

12.2 - 45 W
43° x 16°



Convert Recessed

517

330 mm



●
34

1000 mm



12.2 - 45 W
43° x 16°





Odeon Residence Project, Nîmes, France.
In collaboration with Oceanis Promotion.
Projet de résidence de l'Odéon, Nîmes, France.
En collaboration avec Oceanis Promotion.

Lenses Optiques

Elliptical lenses allow you to illuminate more wall width with a minimal number of pieces.

Les optiques elliptiques permettent d'éclairer plus de largeur de mur avec un minimum de pièces.

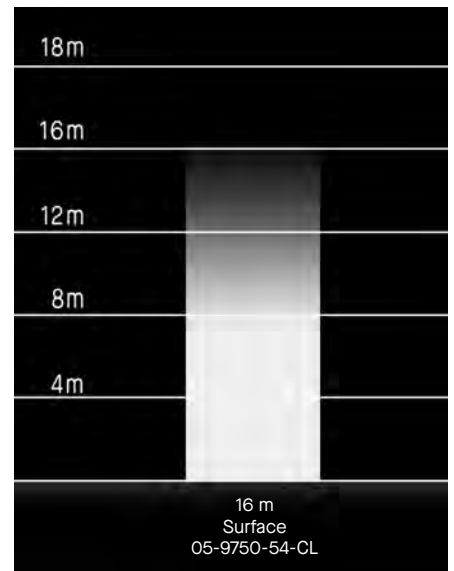

Elliptical lens 41° x 13° (05-9750-54-CL)
Optique elliptique 41° x 13° (05-9750-54-CL)

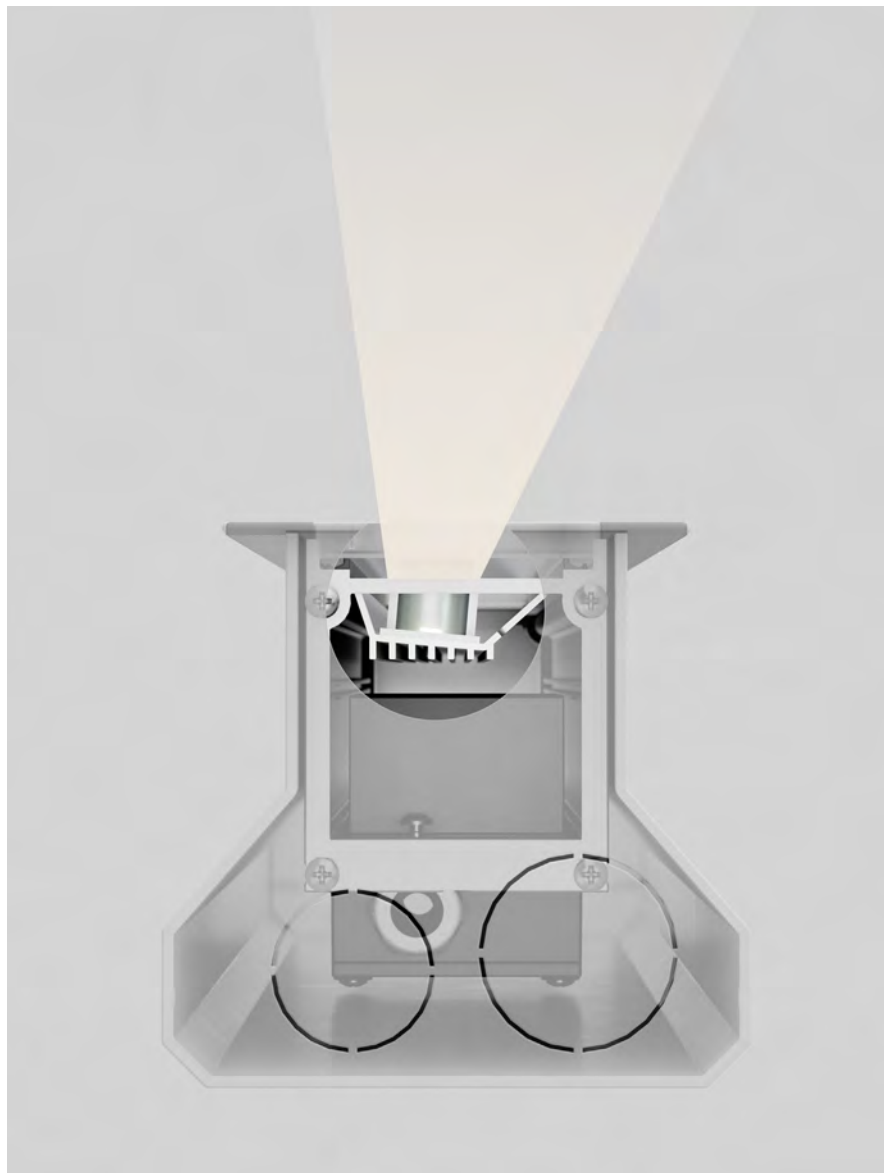

5° tilted LED module in the recessed version to direct the light flow on the wall and eliminate residual light.
Module LED incliné 5° dans la version encastrée pour diriger le flux lumineux sur le mur sans générer de lumière résiduelle.

Convert Surface

BODY MAT	DIF MAT		50000h	3
AL	GLA		L80 B20	MacAdam

Convert Surface 356mm

IP	IK	UGR	BREEAM		SEA SIDE SUITABLE			
66	03	<13				±90°		

54

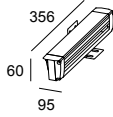

LED							
K	CRI	W Total	Real Lm	Optics	Code		
3000	80	12.9	1170	Eliptic 41° x 13°	05-E099 - 54 - CL	ON-OFF	220-240V

Convert Surface 984mm

IP	IK	BREEAM		SEA SIDE SUITABLE			
66	03				±90°		

54

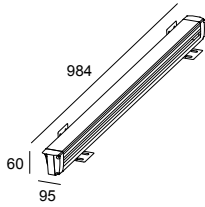

LED							
K	CRI	W Total	Real Lm	Optics	Code		
3000	80	36.5	2909	Eliptic 41° x 13°	05-E103 - 54 - CL	ON-OFF	220-240V

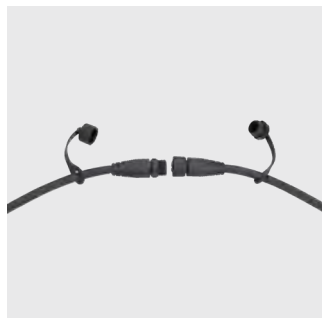

Includes wiring with quick and sealed connection for easy and safe installation.

Comprend le câblage avec connexion rapide et étanche pour une installation facile et sûre.

BODY MAT	DIF MAT		50000h	3
AL	GLA		L80 B20	MacAdam

Convert Recessed 330mm

IP	IK	BREEAM			SEA SIDE SUITABLE		
65-67	10		250 Kg				

34

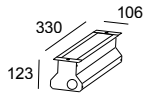

LED							
K	CRI	W Total	Real Lm	Optics	Code		
3000	80	15.6	1261	Eliptic 43° x 19°	55-E074 - 34 - CL	ON-OFF	100-240V

317x133

Convert Recessed 1000mm

IP	IK	UGR	BREEAM			SEA SIDE SUITABLE		
65-67	10	<10		250 Kg				

34

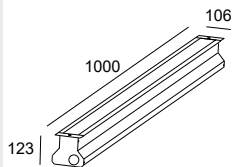

LED							
K	CRI	W Total	Real Lm	Optics	Code		
3000	80	45.7	3522	Eliptic 43° x 19°	55-E109 - 34 - CL	ON-OFF	220-240V

987x133

Fixing accessories Accessoires de fixation



Extending arms 307mm
Bras de rallonge 307 mm

71-E155-CA-CA



Extension 1000 mm
Rallonge 1 000 mm

71-E438-05-05

Extension 5000 mm
Rallonge 5 000 mm

71-E428-05-05



Connector T
Connecteur en T

71-E547-05-05



Recess case
Boitier d'encastrement

Included



Interlinking accessory
Accessoire d'enchaînement

Included

Cube Linear

Designed by LedsC4 Architectural



Precision and control
to illuminate complex
architecture

Précision et contrôle pour
éclairer des architectures
exigeantes

Cube Linear is designed with the precision of a watch piece. Its lenses have been developed to meet the needs of specific architectural contours, offering the utmost in quality and comfort. The collection features specific mechanised features developed to ensure quick installation and maintenance.

Cube Linear est conçue avec la précision d'une pièce d'horlogerie. Ses optiques ont été développées pour répondre aux besoins de contours architecturaux spécifiques, avec une qualité et un confort maximum. La collection possède des fonctions mécanisées spécifiques développées pour permettre une installation rapide et faciliter l'entretien.

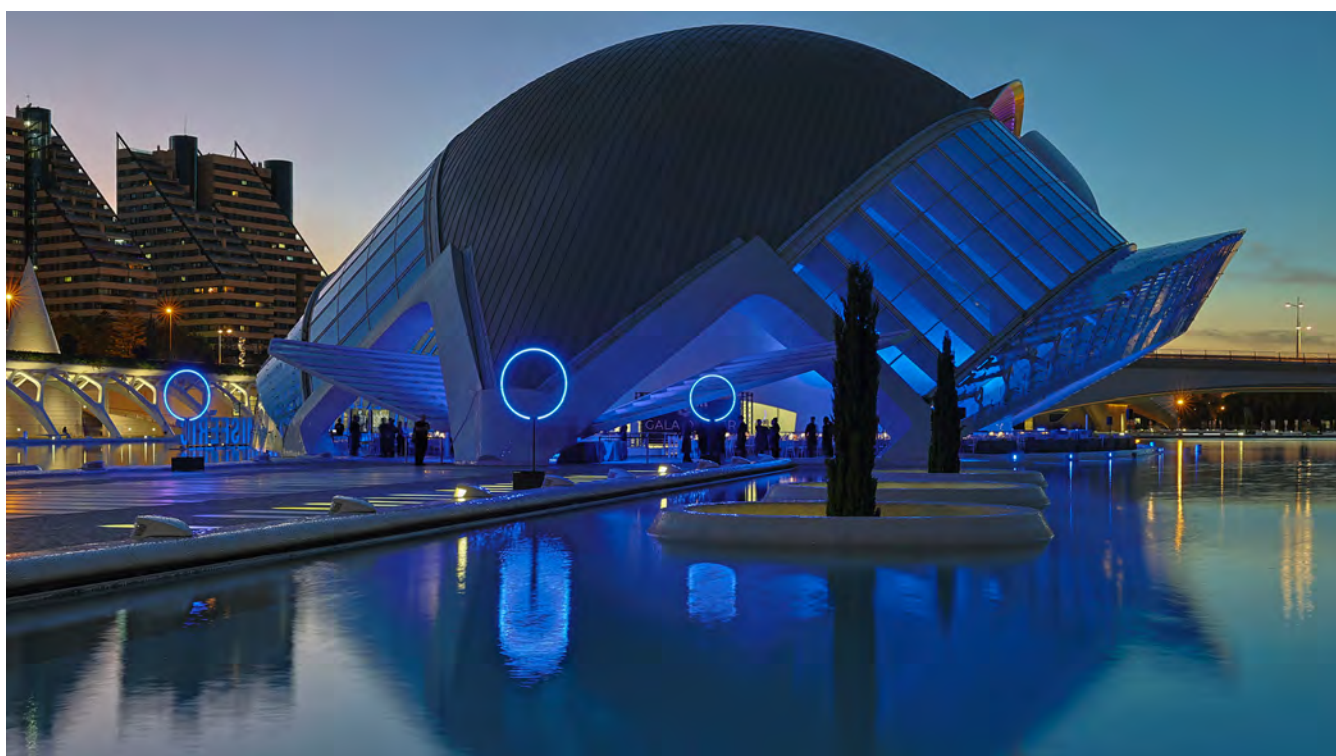



Lenses Optiques



Cube Linear Efficiency
(12°x36°/18°x58°)
Elliptical lenses.
Optiques elliptiques.



Cube Linear Efficiency (6°)
Symmetrical lenses.
Optiques symétriques.



Cube Linear Comfort (6°)
Symmetrical lenses with
Honeycomb.
Optiques symétriques avec
Honeycomb.

Cube Linear Efficiency

Maximum efficiency Efficacité maximale

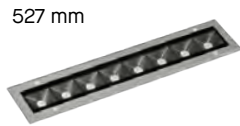
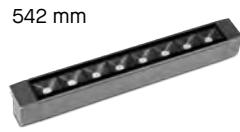

Cube Linear Comfort

Excellent visual comfort Excellent confort visuel

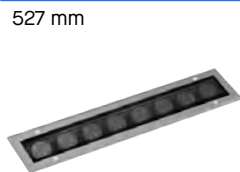
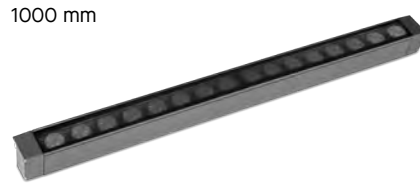

Smart

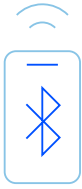

We've also incorporated smart technology that adds chromatic dynamism to lit spaces with the RGBW DMX RDM and DALI2 systems.

Nous intégrons la technologie Smart qui ajoute du dynamisme chromatique aux espaces éclairés avec les systèmes RGBW, DMX, RDM et DALI2.



This is a light for every moment that adapts to the geometries and modular spaces offered by architecture

Une lumière pour chaque moment capable de s'adapter aux géométries et aux espaces modulaires qu'offre l'architecture

Lenses Optiques

Light for façades up to 40 metres high
Lumière pour façades jusqu'à 40 mètres de haut

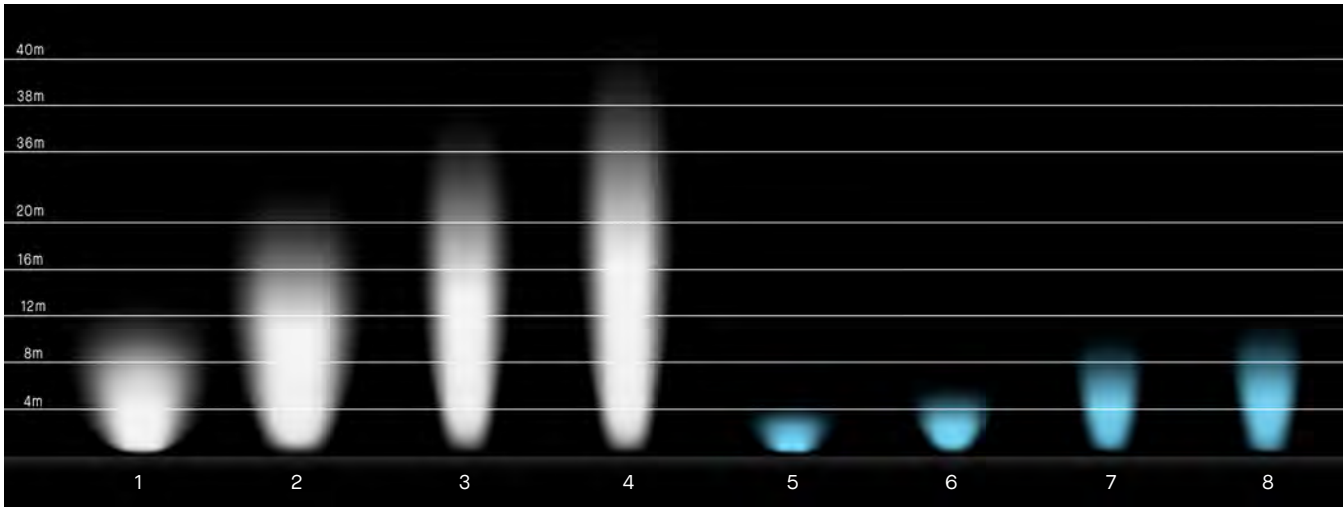

1
Cube Linear Efficiency
14 m
BD13-88W8E6DSZ5
18 × 58°

3
Cube Linear Comfort
36,5 m
BD14-88W8S1DSZ5
6°

5
Cube Linear Efficiency RGBW
3,9 m
BD13-58NNE6DNZ5
18 × 58°

7
Cube Linear Comfort RGBW
9,2 m
BD14-58NNS1DNZ5
6°

2
Cube Linear Efficiency
21 m
BD13-88W8E5DSZ5
12 × 36°

4
Cube Linear Efficiency
39,5 m
BD13-88W8S1DSZ5
6°

6
Cube Linear Efficiency RGBW
5,5 m
BD13-58NNE5DNZ5
12 × 36°

8
Cube Linear Efficiency RGBW
10,5 m
BD13-58NNS1DNZ5
6°



1 **2** **3**
Includes wiring with quick and sealed connection for easy and safe installation.
Comprend le câblage avec connexion rapide et étanche pour une installation facile et sûre.

Installations Installations



Optional tilting visor on
surface-mounted versions
Visière inclinable en option
dans les versions en saillie



Integrated goniometer in
flush-mount models
Goniomètre intégré dans
les modèles à encastrer

The integrated goniometer makes it possible to easily swivel the LED module up to 10° from the outside of the light fitting and align the tilt of the light between the light fittings.
Le goniomètre intégré permet d'incliner facilement le module LED jusqu'à 10° depuis l'extérieur du luminaire et d'aligner les degrés d'inclinaison de la lumière entre les luminaires.

1



2



3



Cube

Linear Efficiency

BODY MAT	DIF MAT	50000h
AL	GL TMP	L80 B20

Cube Linear Efficiency 500mm

IP	IK	UGR				
66-67	10	<10				

Code example / Exemple d'élaboration d'une référence: **BD11-34V8S1BBZ5**

Model		W	K	CRI	Optics	Lumens	Source	Finishes
 BD11 - Surface Z5	34V8	33.8	2700	80	S1 6°	3160	BB 48 VDC	Z5
	34W8	33.8	3000	80	E5 12°-36°	3068		34
	34X8	33.8	4000	80	E6 18°-58°	2150		
 BD15 - Recessed 34	44V8	44.2	2700	80	S1 6°	4444	DS DALI-2/PUSH 220-240V	
	44W8	44.2	3000	80	E5 12°-36°	4114		
	44X8	44.2	4000	80	E6 18°-58°	3020		
	29NN*	23.6	RGBW	4000	S1 6°	1971	DN** DMX RDM 220-240V	
				E5 12°-36°	1904			
				E6 18°-58°	1344			

Cube Linear Efficiency 1000mm

IP	IK	UGR				
66-67	10	<10				

Code example / Exemple d'élaboration d'une référence: **BD13-67V8S1BBZ5**

Model		W	K	CRI	Optics	Lumens	Source	Finishes
 BD13 - Surface Z5	67V8	67.6	2700	80	S1 6°	6320	BB 48 VDC	Z5
	67W8	67.6	3000	80	E5 12°-36°	6136		34
	67X8	67.6	4000	80	E6 18°-58°	4300		
 BD17 - Recessed 34	88V8	88.4	2700	80	S1 6°	8888	DS DALI-2 / PUSH 220-240V	
	88W8	88.4	3000	80	E5 12°-36°	8628		
	88X8	88.4	4000	80	E6 18°-58°	6040		
	58NN*	44.1	RGBW	4000	S1 6°	3942	DN** DMX RDM 220-240V	
				E5 12°-36°	3808			
				E6 18°-58°	2688			

* The indicated flow corresponds to the temperature White = 4000 K





* Le flux indiqué correspond à la température White= 4 000 K

** This product may require programming by a specialist. LedsC4 offers consulting services on control systems and programming in the factory or on-site. Ask your sales agent for more info.





** Ce produit peut nécessiter une programmation par un spécialiste. LedsC4 offre des services de conseils pour les systèmes de contrôle et de programmation en usine ou sur place. Consultez votre agent commercial.

BODY MAT	DIF MAT	50000h
AL	GL TMP	L80 B20



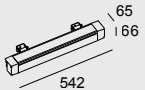

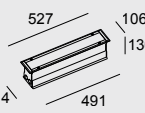
Cube Linear Comfort 500mm

IP	IK	UGR				
66-67	10	<10				





Code example / Exemple d'élaboration d'une référence: **BD12-34V8S1BBZ5**

Model		W	K	CRI	Optics	Lumens	Source	Finishes
 <p>BD12 - Surface ● Z5</p>	34V8	33.8	2700	80	S1 6°	2528	BB  48 VDC	Z5 ●
	34W8	33.8	3000	80				34 ●
	34X8	33.8	4000	80				
 <p>BD16 - Recessed ● 34</p>	44V8	44.2	2700	80	S1 6°	3555	DS  DALI-2/PUSH 220-240V	
	44W8	44.2	3000	80				
	44X8	44.2	4000	80				
	29NN*	23.6	RGBW	4000	S1 6°	1568	DN**  DMX RDM 220-240V	

Cube Linear Comfort 1000mm

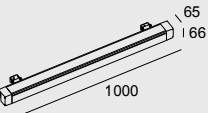
IP	IK	UGR				
66-67	10	<10				

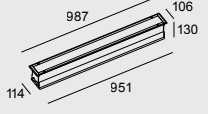
Code example / Exemple d'élaboration d'une référence: **BD14-67V8S1BBZ5**

Model		W	K	CRI	Optics	Lumens	Source	Finishes
 <p>BD14 - Surface ● Z5</p>	67V8	67.6	2700	80	S1 6°	5056	BB  48 VDC	Z5 ●
	67W8	67.6	3000	80				34 ●
	67X8	67.6	4000	80				
 <p>BD18 - Recessed ● 34</p>	88V8	88.4	2700	80	S1 6°	7110	DS  DALI-2/PUSH 220-240V	
	88W8	88.4	3000	80				
	88X8	88.4	4000	80				
	58NN*	44.1	RGBW	4000	S1 6°	3136	DN**  DMX RDM 220-240V	

Power supplies

P. 985

Sources d'alimentation



ON-OFF
IP20

White
500 + 1000
Efficiency

Max. 75W

71-A258-00-00



ON-OFF
IP67

Constant
Voltage

Max. 100W

71-B660-00-00

White
500 + 1000
Comfort

Max. 150W

71-A2589-00-00

Max. 160W

71-B661-00-00

Max. 240W

71-B662-00-00

Max. 400W

71-B678-00-00

Max. 600W







71-B079-00-00

48V (BB)

DALI-2
220-240V (DS)



DMX (DN)

Connection accessories
Accessoires de connexion

	Extension 1000 mm (Power) Rallonge 1 000 mm (Power)	71-E437-05-05	-	71-E438-05-05
	Extension 5000 mm (Power) Rallonge 5 000 mm (Power)	71-E427-05-05	-	71-E428-05-05
	Extension 10000 mm (Power) Rallonge 10 000 mm (Power)	71-E552-05-05	-	-
	Connector T (Power) Connecteur en T (Power)	71-E557-05-05	-	71-E547-05-05
	Extension 1000 mm (Power+DALI Signal) Rallonge 1 000 mm (Power+DALI Signal)	-	71-E440-05-05	-
	Extension 5000 mm (Power+DALI Signal) Rallonge 5 000 mm (Power+DALI Signal)	-	71-E429-05-05	-
	Connector T (Power+DALI Signal) Connecteur en T (Power+DALI Signal)	-	71-E548-05-05	-
	Extension 1000 mm (DMX Signal) Rallonge 1 000 mm (DMX Signal)	-	-	71-E441-05-05
	Extension 5000 mm (DMX Signal) Rallonge 5 000 mm (DMX Signal)	-	-	71-E430-05-05
	Connector T (DMX Signal) Connecteur en T (DMX Signal)	-	-	71-E549-05-05

	Surface BB (Not Included)	Recessed BB (Not Included)	Surface DN (DMX)	Recessed DN (DMX)	Surface DS (DALI)	Recessed DS (DALI)
--	---------------------------------	----------------------------------	------------------------	-------------------------	-------------------------	--------------------------

Lens accessories Accessoires optiques

	Visor (Only for 542 mm Surface version) Visière (uniquement pour version Surface de 542 mm)	71-E389-Z5-Z5	-	71-E389-Z5-Z5	-	71-E389-Z5-Z5	-
	Visor (Only for 1000 mm Surface version) Visière (uniquement pour version Surface de 1 000 mm)	71-E390-Z5-Z5	-	71-E390-Z5-Z5	-	71-E390-Z5-Z5	-

Fixing accessories Accessoires de fixation

	Base for surface mounting Socle à fixer en surface	Included	-	Included	-	Included	-
	Linear metal recessing case Boîtier d'encastrement métallique linéaire	-	Included	-	Included	-	Included
	Cover to stop cement from entering during installation Cache permettant d'éviter la pénétration de ciment en cours d'installation	-	Included	-	Included	-	Included

Union accessories Accessoires d'union

	Plates for interlinked installation Plaques pour installation enchaînée	-	Included	-	Included	-	Included
-------------------------------------------------------------------------------------	----------------------------------------------------------------------------	---	----------	---	----------	---	----------

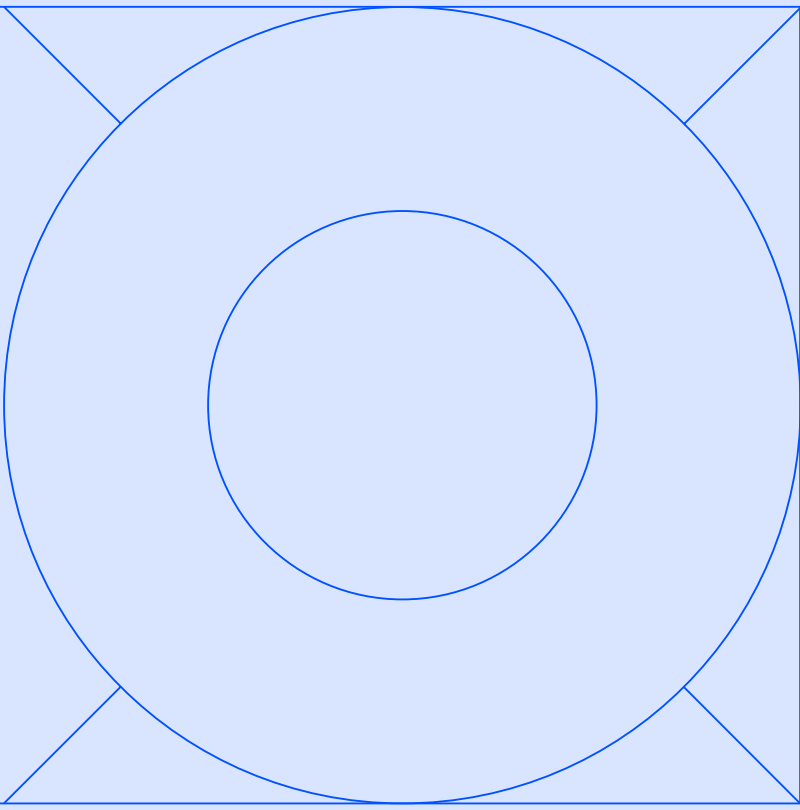

Spotlights Projecteurs

Cube

530

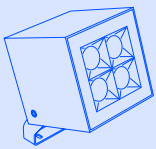

Max

540



Eko

550

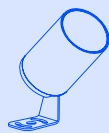

Modis

553

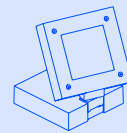

Hubble

558



Thor

568



Micro

572



Zoom

576

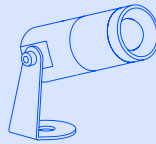

Suv

582

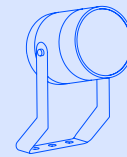

Helio

583



Cube

Designed by LedsC4 Architectural



+ Cube

Precision and control Précision et contrôle

The Cube collection has been designed to illuminate architecture with balanced lighting, sculpting shapes without leaving residual light. La collection Cube a été conçue pour éclairer l'architecture de manière équilibrée, sans lumière résiduelle et en la façonnant.





Cube

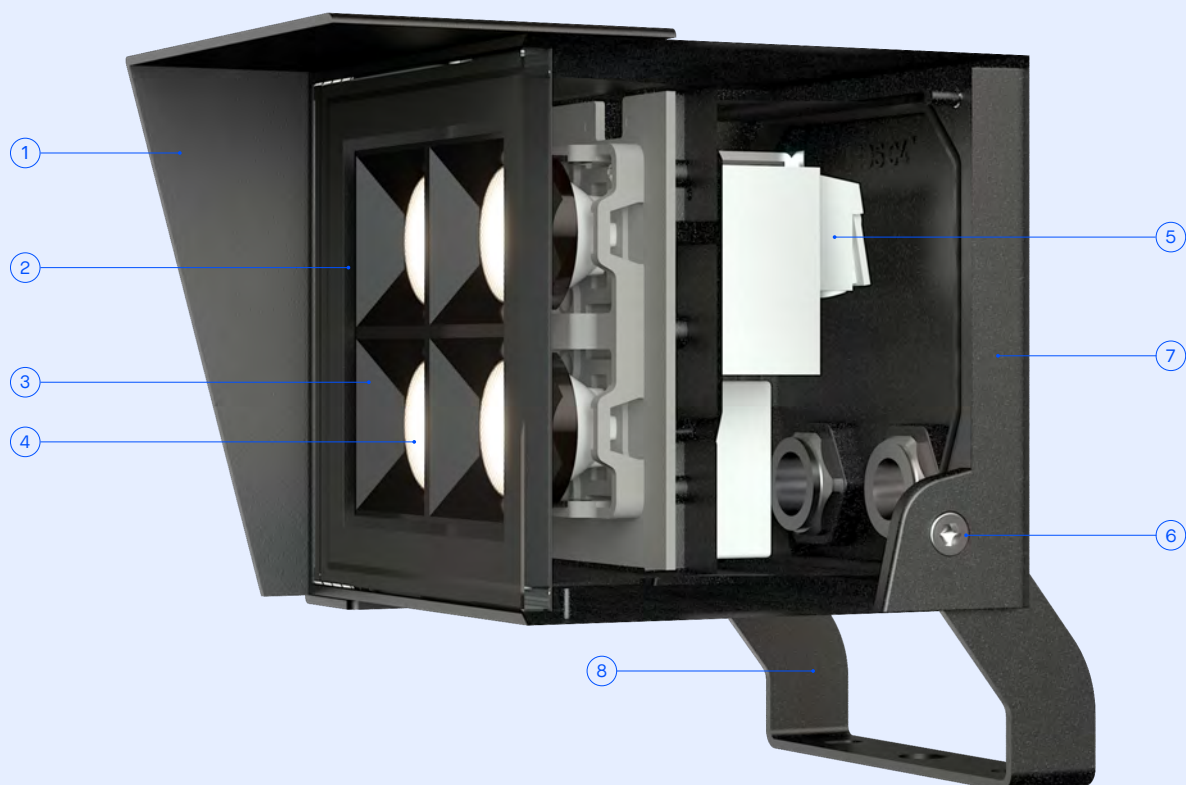

① Anti-glare visor
Visière anti-éblouissement

② 6 mm glass diffuser
Diffuseur en verre de 6 mm

③ Trim to maximise visual comfort
Enjoliveurs pour maximiser le confort visuel

④ Lenses from Super Spot to Flood
Optiques de Super Spot à Flood

⑤ Tool-free connection
Connexion sans outils

⑥ AISI316 stainless steel screws
Vis en acier inoxydable AISI316

⑦ Injected aluminium casing with special protection against rust
Corps en aluminium injecté avec protection spéciale antirouille

⑧ 90° tilting arm
Bras basculant 90°



Cube 4 LEDS. Grec Festival 2021.
Photography: Jordi Anguera.

Includes wiring with quick and sealed connection for easy and safe installation.

Comprend le câblage avec connexion rapide et étanche pour une installation facile et sûre.

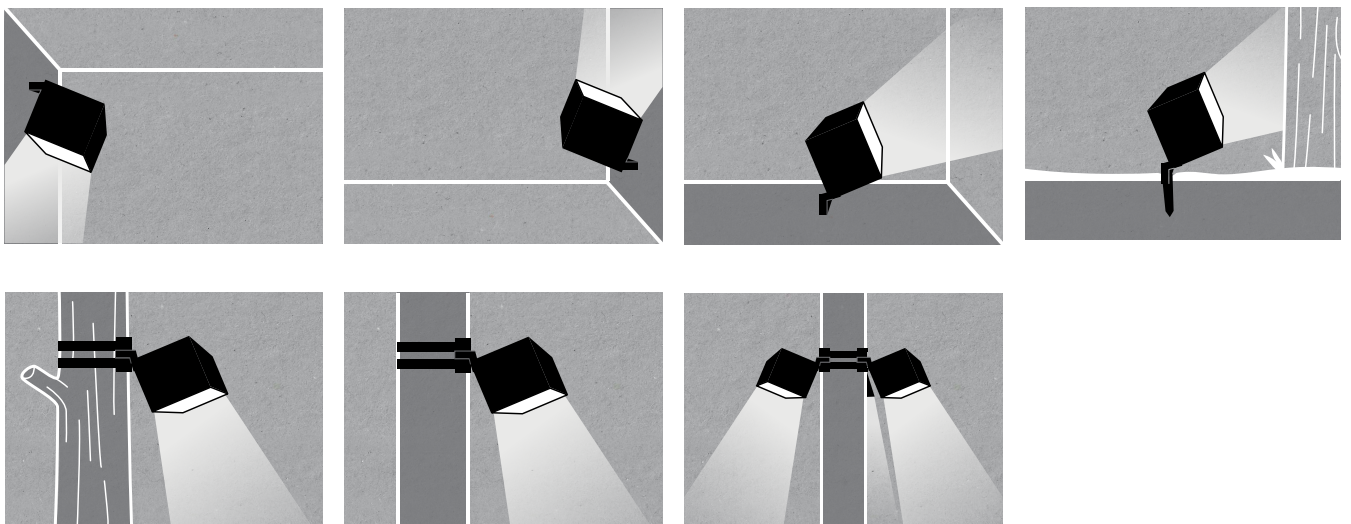



Cube Spot 1 LED

BODY MAT
AL

DIF MAT
GLA

50000h
L80 B20

IP
66

IK
03



BREEAM

3
MacAdam



SEA SIDE SUITABLE

90°



DRIVER

Code example / Exemple d'élaboration d'une référence: **AN11-P5V8S1BBZ5**

Model		W	K	CRI	Optics	Real Lm	Source	Finishes	
	AN11 - Spot 1 LED	P5V8	4.5	2700	80	S1 7°	387 - 411	BB 3V/max. 1500mA	Z5
		P5W8	4.5	3000	80				
		P5X8	4.5	4000	80				
	P5V8	5	2700	80	S2 16°	426 - 452	BB 24V/max. 200mA		
	P5W8	5	3000	80	M3 37°	479 - 509			
	P5X8	5	4000	80	F1 54°	459 - 487			
					E7 v:35° x h:70°	328 - 348			

Cube Spot 4 LEDS

BODY MAT
AL

DIF MAT
GLA

50000h
L80 B20

IP
66

IK
07

BREEAM



SEA SIDE SUITABLE

90°



DRIVER

Code example / Exemple d'élaboration d'une référence: **AN12-P6V8S1DUZ5**

Model		W	K	CRI	Optics	Real Lm	Source	Finishes	
	AN12 - Spot 4 LEDS	P6V8	6.2	2700	80	S1 7°	647 - 687	DU DALI-2 100-240V	Z5
		P6W8	6.2	3000	80				
		P6X8	6.2	4000	80				
	12V8	12.4	2700	80	S1 7°	1158 - 1230	OU ON-OFF 100-240V		
	12W8	12.4	3000	80					
	12X8	12.4	4000	80					
	12V8	11.9	2700	80	S2 16°	1405 - 1492	OU ON-OFF 100-240V		
	12W8	11.9	3000	80	M3 35°	1648 - 1750	DU DALI-2 100-240V		
	12X8	11.9	4000	80	F1 51°	1547 - 1643			
					E7 35x70°	970 - 1031			
	16NN*	19.6	RGBW 4000	80	S1 7°	376	BB** DMX 24VDC		
					S2 16°	417			
				M3 35°	512				
				F1 51°	480				
				E7 v:35° x h:70°	240				

* The indicated flow corresponds to the temperature White = 4000 K

* Le flux indiqué correspond à la température White= 4 000 K

** This product may require programming by a specialist. LedsC4 offers consulting services on control systems and programming in the factory or on-site. Ask your sales agent for more info.

** Ce produit peut nécessiter une programmation par un spécialiste. LedsC4 offre des services de conseils pour les systèmes de contrôle et de programmation en usine ou sur place. Consultez votre agent commercial.

Cube Spot 9 LEDS

BODY MAT AL	DIF MAT GLA	50000h L80 B20	IP 66	IK 09						
----------------	----------------	-------------------	----------	----------	--	--	--	--	--	--

Code example / Exemple d'élaboration d'une référence: **AN13-24V8S2DUZ5**

Model	W	K	CRI	Optics	Real Lm	Source	Finishes
<p>AN13 - Spot 9 LEDS</p>	24V8	24	2700	80	S2 16° 1939 - 2058	DU DALI-2 120-277V	Z5
	24W8	24	3000	80	M3 32° 2274 - 2415		
	24X8	24	4000	80	F1 43° 2124 - 2255		
					E7 v:35° x h:70° 1966 - 2086		
	27V8	27	2700	80	S1 6° 2577 - 2736	DU DALI-2 120-277V	
	27W8	27	3000	80			
	27X8	27	4000	80			
	3PV8	31.3	2700	80	S1 6° 3268 - 3470	OU ON-OFF 100-240V	
	3PW8	31.3	3000	80	S2 16° 2458 - 2611		
	3PX8	31.3	4000	80	M3 32° 2884 - 3063		
				F1 43° 2694 - 2860			
				E7 v:35° x h:70° 2492 - 2647			
25NN*	27	RGBW 4000	80	S1 6° 846	DM** DMX 120-277V 		
				S2 16° 936			
				M3 32° 1152			
				F1 43° 1080			
				E7 v:35° x h:70° 540			

Cube Spot 16 LEDS

BODY MAT AL	DIF MAT GLA	50000h L80 B20	IP 66	IK 08						
----------------	----------------	-------------------	----------	----------	--	--	--	--	--	--

Code example / Exemple d'élaboration d'une référence: **AN14-5PV8S1DUZ5**





Model	W	K	CRI	Optics	Real Lm	Source	Finishes
<p>AN14 - Spot 16 LEDS</p>	5PV8	50	2700	80	S1 7° 4969	DU DALI-2 220-240V	Z5
	5PW8	50	3000	80	S2 16° 4847		
	5PX8	50	4000	80	M3 35° 5541		
					F1 50° 5215		
					E7 v:35° x h:70° 3707 - 3937		
	53V8	52.8	2700	80	S1 7° 4820 - 5118	OU ON-OFF 100-240V	
	53W8	52.8	3000	80	S2 16° 4702 - 4993		
	53X8	52.8	4000	80	M3 35° 5375 - 5707		
					F1 50° 5059 - 5371		
					E7 v:35° x h:70° 3596 - 3819		
34NN*	32.7	RGBW 4000	80	S1 7° 1692	DM** DMX 100-277V 		
				S2 16° 1872			
				M3 35° 2304			
				F1 50° 2160			
				E7 v:35° x h:70° 1080			

* The indicated flow corresponds to the temperature White = 4000 K







* Le flux indiqué correspond à la température White= 4 000 K

** This product may require programming by a specialist. LedsC4 offers consulting services on control systems and programming in the factory or on-site. Ask your sales agent for more info.





** Ce produit peut nécessiter une programmation par un spécialiste. LedsC4 offre des services de conseils pour les systèmes de contrôle et de programmation en usine ou sur place. Consultez votre agent commercial.

	1 LED 4,5W	1 LED 5W	4 LEDS	9 LEDS	16 LEDS
					

Drivers P. 984
Driver

	ON-OFF IP20	71-E217-00-00  71-E218-00-00 	-	-	-
		Min.1 - Max.4			
		71-4914-00-00 	-	-	-
		Min.1 - Max.12			
	DALI2 IP20	-	71-B407-00-00	-	-
	DALI2 IP68	71-E216-00-00	-	-	-
		Min.4 - Max.15			

Fixing accessories
Accessoires de fixation

	Attachment (max. 3 spotlights) Fixation (3 projecteurs maxi.)	71-9746-05-05	71-9746-05-05	71-9746-05-05	-	-
	235mm spiked post Piquet de 235 mm	71-9997-05-05	71-9997-05-05	71-9997-05-05	71-9997-05-05	71-9997-05-05
	302mm spiked post Piquet de 302 mm	71-9998-05-05	71-9998-05-05	71-9998-05-05	71-9998-05-05	71-9998-05-05
	Mount for columns or trees Fixation pour mâts ou arbres	71-9999-Z5-Z5	71-9999-Z5-Z5	71-9999-Z5-Z5	71-9999-Z5-Z5	71-9999-Z5-Z5
	Wall, floor and lawn extender (300/500/800mm) Rallonge pour mur, sol et gazon (300/500/800 mm)	71-E052-Z5-Z5	71-E052-Z5-Z5	71-E052-Z5-Z5	-	-

Lens accessories
Accessoires optiques

	Visor Visière	Included	Included	Included	Included	Included
-------------------------------------------------------------------------------------	------------------	----------	----------	----------	----------	----------

Connective controllers P. 969
Contrôleurs connectés

	Consult the available control systems / Consultez les systèmes de contrôle disponibles: DALI2 / DALI2 Bluetooth wireless / Sans fil Bluetooth DMX / DMX Autonomous / Autonome
-------------------------------------------------------------------------------------	--------------------------------------------------------------------------------------------------------------------------------------------------------------------------------------------------

	1 White LED (Low voltage)	4 White LED ON-OFF (100-240V)	4 White LED DALI-2 (100-240V)	4 RGBW LED DMX (low voltage)	9 White LED ON-OFF (100-240V)
--	------------------------------	-------------------------------------	-------------------------------------	------------------------------------	-------------------------------------









Connection accessories

Accessoires de connexion

	Extension 1000 mm (Power) Rallonge 1 000 mm (Power)	71-E437-05-05	71-E438-05-05	-	71-E437-05-05	71-E438-05-05
	Extension 5000 mm (Power) Rallonge 5 000 mm (Power)	71-E427-05-05	71-E428-05-05	-	71-E427-05-05	71-E428-05-05
	Extension 10000 mm (Power) Rallonge 10 000 mm (Power)	71-E552-05-05	-	-	71-E552-05-05	-
	Connector T (Power) Connecteur en T (Power)	71-E557-05-05	71-E547-05-05	-	71-E557-05-05	71-E547-05-05
	Extension 1000 mm (Power+DALI Signal) Rallonge 1 000 mm (Power+DALI Signal)	-	-	-	71-E441-05-05	-
	Extension 5000 mm (Power+DALI Signal) Rallonge 5 000 mm (Power+DALI Signal)	-	-	-	71-E430-05-05	-
	Connector T (Power+DALI Signal) Connecteur en T (Power+DALI Signal)	-	-	-	71-E549-05-05	-
	Extension 1000 mm (DMX Signal) Rallonge 1 000 mm (DMX Signal)	-	-	71-E440-05-05	-	-
	Extension 5000 mm (DMX Signal) Rallonge 5 000 mm (DMX Signal)	-	-	71-E429-05-05	-	-
	Connector T (DMX Signal) Connecteur en T (DMX Signal)	-	-	71-E548-05-05	-	-

9 White LED DALI-2 (120-277V)	9 RGBW LED DMX (120-277V)	16 White LED ON-OFF (100-240V)	16 White LED DALI-2 (220-240V)	16 RGBW LED DMX (100-277V)
				

Connection accessories
Accessoires de connexion

	Extension 1000 mm (Power) Rallonge 1 000 mm (Power)	-	71-E438-05-05	71-E438-05-05	-	71-E438-05-05
	Extension 5000 mm (Power) Rallonge 5 000 mm (Power)	-	71-E428-05-05	71-E428-05-05	-	71-E428-05-05
	Extension 10000 mm (Power) Rallonge 10 000 mm (Power)	-	-	-	-	-
	Connector T (Power) Connecteur en T (Power)	-	71-E547-05-05	71-E547-05-05	-	71-E547-05-05
	Extension 1000 mm (Power+DALI Signal) Rallonge 1 000 mm (Power+DALI Signal)	-	71-E441-05-05	-	-	71-E441-05-05
	Extension 5000 mm (Power+DALI Signal) Rallonge 5 000 mm (Power+DALI Signal)	-	71-E430-05-05	-	-	71-E430-05-05
	Connector T (Power+DALI Signal) Connecteur en T (Power+DALI Signal)	-	71-E549-05-05	-	-	71-E549-05-05
	Extension 1000 mm (DMX Signal) Rallonge 1 000 mm (DMX Signal)	71-E440-05-05	-	-	71-E440-05-05	-
	Extension 5000 mm (DMX Signal) Rallonge 5 000 mm (DMX Signal)	71-E429-05-05	-	-	71-E429-05-05	-
	Connector T (DMX Signal) Connecteur en T (DMX Signal)	71-E548-05-05	-	-	71-E548-05-05	-

Max

Designed by LedsC4 Architectural



Bollard
P. 738



Wall Fixture
P. 788



Ceiling
P. 852



Downlight
P. 598



Uplight
P. 630



Perfect balance Équilibre parfait

The Max collection offers a wide variety of options and excellent lens control in a streamlined design. The small size of the spotlights allows them to blend into the architecture, going virtually unnoticed, making them a popular choice among the most discerning lighting designers.

La collection Max offre une grande variété d'options et un excellent contrôle optique sans renoncer au minimalisme. La petite taille des projecteurs facilite leur intégration dans l'architecture, les faisant passer pratiquement inaperçus, ce qui en fait une option très demandée parmi les concepteurs d'éclairage les plus exigeants.

Ø82 mm



Ø58 mm



Ø30 mm



14



34



DL



E3



J6



Z5



60



Max Medium in Fiske Bar Barcelona project. Photography: Salva López.
Max Medium en projet, Fiske Bar Barcelona. Photographie : Salva López



BODY MAT
AL

DIF MAT
GLA



50000h
L80 B20

2
MacAdam

Max Mini Spotlight

IP 66	IK 04	1 m	DIM	SEA SIDE SUITABLE	180°	
----------	----------	-----	-----	----------------------	------	--

Code exemple / Exemple d'élaboration d'une référence: **BA18-P2V8S1BBZ5**

Model	W	K	CRI	Optics	Real Lm	Source	Finishes	
BA18 - Ø30mm 	Constant Current 700mA							
	P2P8	2.5	2200	80	S1 10°	163	BB 3V/max.700mA	14*
	P2V8	2.2	2700	80	S2 15°	185		34*
	P2W8	2.2	3000	80	M3 32°	191		60*
	P2X8	2.2	4000	80	F2 53°	158		DL*
								E3*
								J6*
								Z5
	Constant Voltage 24V							
	P3V8	2.5	2700	80	S3 19°	94	BB 24VDC PWM	
P3W8	2.5	3000	80	M3 32°	97			
P3X8	2.5	4000	80	F2 51°	87			

* Please contact our sales team for conditions and delivery times.

* Consultez notre équipe commerciale pour connaître les conditions et les délais de livraison.

Max Medium Spotlight

IP 66	IK 10	1 m	DIM	SEA SIDE SUITABLE	180°	
----------	----------	-----	-----	----------------------	------	--

Code exemple / Exemple d'élaboration d'une référence: **A118-P4V9S1BBZ5**

Model	W	K	CRI	Optics	Real Lm	Source	Finishes	
A118 - Ø58mm 	Constant Current 350mA							
	P4V9	4	2700	90	S1 9°	286	BB 12V/max.350mA	14*
	P4W9	4	3000	90				34*
	P4X9	4	4000	90				60*
								DL*
								E3*
								J6*
								Z5
	Constant Voltage 24V							
	P6V9	6	2700	90	S1 9°	204	BB 24VDC PWM	
	P6W9	6	3000	90				
	P6X9	6	4000	90				
	P8V9	7.9	2700	90	S2 17°	519	BB 24VDC PWM	
	P8W9	7.9	3000	90	M2 27°	459		
P8X9	7.9	4000	90	F1 50°	423			



* Please contact our sales team for conditions and delivery times.

* Consultez notre équipe commerciale pour connaître les conditions et les délais de livraison.

Max Big Spotlight

IP 66	IK 10	1 m	DIM	SEA SIDE SUITABLE	90°	LED
----------	----------	-----	-----	----------------------	-----	-----

Code example / Exemple d'élaboration d'une référence: **AT18-18V9S3BBZ5**

Model	W	K	CRI	Optics	Real Lm	Source	Finishes	
AT18 - Ø82mm 	Constant Current							
	13V9	13,7	2700	90	S1 10°	931 - 1054	BB  36V/max.350mA	14* 
	13W9	13,7	3000	90				34* 
	13X9	13,7	4000	90				60* 
	18P8	17,3	2200	80	S3 21°	1844 - 2126	BB  36V/max.500mA	DL* 
	18V9	17,3	2700	90	M3 31°	1902 - 2191		E3* 
	18W9	17,3	3000	90	F2 40°	1565 - 1812		J6* 
	18X9	17,3	4000	90				Z5 
	Constant Voltage 24V							
	14V9	13,8	2700	90	S3 16°	1086	BB  24VDC PWM	
	14W9	13,8	3000	90	M2 28°	1076		
	14X9	13,8	4000	90	F2 51°	1120		

* Please contact our sales team for conditions and delivery times.
 * Consultez notre équipe commerciale pour connaître les conditions et les délais de livraison.

OUTDOOR

SPOTLIGHTS | PROJECTEURS

Max Mini







Max Medium



Max Big









Lens accessories

Accessoires optiques



	Wall washer diffuser (5u.) Diffuseur lèche-mur (5 u.)		71-E462-00-00	71-E463-00-00	71-E464-00-00
	Honeycomb panel (5u.) Grille en nid d'abeille (5 u.)		71-E422-00-00	71-E131-00-00	71-E263-00-00
	Square diffuser (5u.) Diffuseur carré (5 u.)		71-E421-00-00	71-E135-00-00	71-E262-00-00
	Elliptical diffuser (5u.) Diffuseur elliptique (5 u.)		71-E420-00-00	71-E141-00-00	71-E261-00-00
	Opal diffuser (5u.) Diffuseur opalin (5 u.)		71-E419-00-00	71-E133-00-00	71-E260-00-00
	Visor Visière	Z5 ●	71-E417-Z5-00	71-E145-Z5-Z5	71-E259-Z5-00
		J6 ● *	71-E417-J6-00	71-E145-J6-J6	71-E259-J6-00
		E3 ● *	71-E417-E3-00	71-E145-E3-E3	71-E259-E3-00
		DL ● *	71-E417-DL-00	71-E145-DL-DL	71-E259-DL-00
		14 ○ *	71-E417-14-00	71-E145-14-14	71-E259-DL-00
		60 ● *	71-E417-60-00	71-E145-60-60	71-E259-60-00
		34 ● *	71-E417-34-00	71-E145-34-34	71-E259-60-00
	Cylindrical visor Visière cylindrique	Z5 ●	71-E605-Z5-00	71-E606-Z5-00	71-E607-Z5-00
		J6 ● *	71-E605-J6-00	71-E606-J6-00	71-E607-J6-00
		E3 ● *	71-E605-E3-00	71-E606-E3-00	71-E607-E3-00
		DL ● *	71-E605-DL-00	71-E606-DL-00	71-E607-DL-00
		14 ○ *	71-E605-14-00	71-E606-14-00	71-E607-DL-00
		60 ● *	71-E605-60-00	71-E606-60-00	71-E607-60-00
		34 ● *	71-E605-34-00	71-E606-34-00	71-E607-60-00

	Max Mini	Max Medium	Max Big
			

Connection accessories
Accessoires de connexion

	IP67 connector (1 input + 1 output) Ø 5.5-7.5 mm, 3 poles Connecteur IP67 (1 entrée + 1 sortie) Ø 5,5 - 7,5 mm, 3 pôles	71-E510-00-00	71-E510-00-00	71-E510-00-00
	IP67 connector (1 input + 2 outputs) Ø 5.5-7.5 mm, 3 poles Connecteur IP67 (1 entrée + 2 sorties) Ø 5,5 - 7,5 mm, 3 pôles	71-E511-00-00 Not for Constant Current	71-E511-00-00 Not for Constant Current	71-E511-00-00 Not for Constant Current
	IP68 connector (1 input + 1 output) Ø 5.5-11.5 mm, 4 poles Connecteur IP68 (1 entrée + 1 sortie) Ø 5,5 - 11,5 mm 4 pôles	71-E512-00-00	71-E512-00-00	71-E512-00-00
	IP68 connector (1 input + 2 outputs) Ø 5.5-11.5 mm, 3 poles Connecteur IP68 (1 entrée + 2 sorties) Ø 5,5 - 11,5 mm, 3 pôles	71-E513-00-00 Not for Constant Current	71-E513-00-00 Not for Constant Current	71-E513-00-00 Not for Constant Current
	IP68 anti-condensation connector (1 input + 1 output) Ø 5.5-12 mm, 4 poles Connecteur anticondensation IP68 (1 entrée + 1 sortie) Ø 5,5 - 12 mm, 4 pôles	71-E122-00-00	71-E122-00-00	71-E122-00-00
	IP68 anti-condensation connector (1 input + 3 output) Ø 5.5-12 mm, 4 poles Connecteur anticondensation IP68 (1 entrée + 3 sorties) Ø 5,5 - 12 mm, 4 pôles	71-E112-00-00 Not for Constant Current	71-E112-00-00 Not for Constant Current	71-E112-00-00 Not for Constant Current
	IP68 connection box (1 input + 5 outputs) Ø 6.5-11 mm, 6 poles Boîtier de raccordement IP67 (1 entrée + 5 sorties) Ø 6,5 - 11 mm, 6 pôles	-	71-9199-05-05	71-9199-05-05

Fixing accessories
Accessoires de fixation

	Spiked post Piquet	71-E143-05-05	71-E143-05-05	-
	302mm spiked post Piquet de 302 mm	-	-	71-9998-05-05
	235mm spiked post Piquet de 235 mm	-	-	71-9997-05-05

Constant Current

Max Mini

**Max Medium
P4 (4W)**

**Max Medium
P7 (6.7W)**

**Max Big
13**

**Max Big
18**



Drivers
Drivers

P. 984



ON-OFF
IP20

71-B682-00-00 **71-A652-00-00** **71-6652-00-00** **71-6652-00-00** **71-7551-00-00**

Min.2 - Max.2

71-3542-00-00 **71-3542-00-00** **71-3542-00-00** - -

Min.1 - Max.22 Min.1 - Max.6 Min.1 - Max.3



ON-OFF
IP68

71-E014-00-00 **71-E079-00-00** **71-E079-00-00** **71-E079-00-00** -

Min.2 - Max.4 Min.1 - Max.4 Min.1 - Max.2



DALI2
IP20

71-A190-00-00 **71-A192-00-00** **71-A192-00-00** **71-A191-00-00** **71-A192-00-00**

Min.2 - Max.4 Min.1 - Max.3 Min.1 - Max.2



DALI2
IP68

71-E080-00-00 **71-E083-00-00** **71-E083-00-00** **71-E083-00-00** **71-E085-00-00**

Min.1 - Max.13 Min.1 - Max.4 Min.1 - Max.2

Constant Voltage 24V

Power supplies

P. 985

Sources d'alimentation



ON-OFF
IP20

Max. 20W **71-B650-00-00**

Max. 30W **71-B640-00-00**

Max. 100W **71-B641-00-00**

Max. 150W **71-B642-00-00**

Max. 250W **71-B643-00-00**



DALI2
IP20

Max. 60W **71-B652-00-00**

Max. 150W **71-B653-00-00**

Max. 250W **71-B654-00-00**



DALI2
IP67

Max. 60W **71-B655-00-00**

Max. 160W **71-B656-00-00**



ON-OFF
IP20

Max. 30W **71-B643-00-00**

Max. 60W **71-B645-00-00**

Max. 100W **71-B646-00-00**

Max. 160W **71-B647-00-00**

Max. 240W **71-B648-00-00**

Max. 240W **71-B675-00-00**

Max Spotlight Base

BODY MAT	DIF MAT		50000h	2
AL	GLA		L80 B20	MacAdam

OUTDOOR

Max Mini Spotlight Base

	IP 66	IK 04		SEA SIDE SUITABLE		
--	----------	----------	--	----------------------	--	--

Code example / Exemple d'élaboration d'une référence: **BA26-P2P8S10U14**

Model		W	K	CRI	Optics	Real Lm	Source	Finishes
BA26 - Spotlight Base Mini 	P2P8	2.2	2200	80	S1 10°	152 - 163	OU ON-OFF 100-240V	14*
	P2V8	2.2	2700	80	S2 15°	172 - 185		34*
	P2W8	2.2	3000	80	M3 32°	178 - 191		60*
	P2X8	2.2	4000	80	F2 53°	147 - 158		DL*
								E3*
								J6*
								Z5

Max Medium Spotlight Base

	IP 66	IK 10	SEA SIDE SUITABLE		
--	----------	----------	----------------------	--	--

Code example / Exemple d'élaboration d'une référence: **AI26-P6V9S10U14**

Model		W	K	CRI	Optics	Real Lm	Source	Finishes
AI26 - Spotlight Base Medium 	P6V9	6	2700	90	S1 9°	373	OU ON-OFF 100-240V	14*
	P6W9	6	3000	90				34*
	P6X9	6	4000	90				60*
	P7P8	6	2200	80	S2 17°	519	OU ON-OFF 100-240V	DL*
	P7V9	6	2700	90	M2 27°	459		E3*
	P7W9	6	3000	90	F1 50°	423		J6*
	P7X9	6	4000	90				Z5

Max Big Spotlight Base











	IP 66	IK 10	SEA SIDE SUITABLE		
--	----------	----------	----------------------	--	--

Code example / Exemple d'élaboration d'une référence: **AT26-13V9S10U14**

Model		W	K	CRI	Optics	Real Lm	Source	Finishes
AT26 - Spotlight Base Big 	13V9	13.7	2700	90	S1 10°	921 - 1054	OU ON-OFF 100-240V	14*
	13W9	13.7	3000	90				34*
	13X9	13.7	4000	90				60*
	18P8	17.3	2200	80	S3 21°	1984 - 2126	OU ON-OFF 100-240V	DL*
	18V9	17.3	2700	90	M3 31°	2047 - 2191		E3*
	18W9	17.3	3000	90	F1 40°	1684 - 1812		J6*
	18X9	17.3	4000	90				Z5

* Please contact our sales team for conditions and delivery times.
* Consultez notre équipe commerciale pour connaître les conditions et les délais de livraison.

SPOTLIGHTS | PROJECTEURS

		Max Mini	Max Medium	Max Big
				
Lens accessories Accessoires optiques				
	Wall washer diffuser (5u.) Diffuseur lèche-mur (5 u.)	71-E462-00-00	71-E463-00-00	71-E464-00-00
	Honeycomb panel (5u.) Grille en nid d'abeille (5 u.)	71-E422-00-00	71-E131-00-00	71-E263-00-00
	Square diffuser (5u.) Diffuseur carré (5 u.)	71-E421-00-00	71-E135-00-00	71-E262-00-00
	Elliptical diffuser (5u.) Diffuseur elliptique (5 u.)	71-E420-00-00	71-E141-00-00	71-E261-00-00
	Opal diffuser (5u.) Diffuseur opalin (5 u.)	71-E419-00-00	71-E133-00-00	71-E260-00-00
	Visor Visière	Z5 ● 71-E417-Z5-00	71-E145-Z5-Z5	71-E259-Z5-00
		J6 ● * 71-E417-J6-00	71-E145-J6-J6	71-E259-J6-00
		E3 ● * 71-E417-E3-00	71-E145-E3-E3	71-E259-E3-00
		DL ● * 71-E417-DL-00	71-E145-DL-DL	71-E259-DL-00
		14 ○ * 71-E417-14-00	71-E145-14-14	71-E259-DL-00
		60 ● * 71-E417-60-00	71-E145-60-60	71-E259-60-00
		34 ○ * 71-E417-34-00	71-E145-34-34	71-E259-60-00
	Cylindrical visor Visière cylindrique	Z5 ● 71-E605-Z5-00	71-E606-Z5-00	71-E607-Z5-00
		J6 ● * 71-E605-J6-00	71-E606-J6-00	71-E607-J6-00
		E3 ● * 71-E605-E3-00	71-E606-E3-00	71-E607-E3-00
		DL ● * 71-E605-DL-00	71-E606-DL-00	71-E607-DL-00
		14 ○ * 71-E605-14-00	71-E606-14-00	71-E607-DL-00
		60 ● * 71-E605-60-00	71-E606-60-00	71-E607-60-00
		34 ○ * 71-E605-34-00	71-E606-34-00	71-E607-60-00
Fixing accessories Accessoires de fixation				
	Spiked post Piquet	71-E633-05-05	71-E633-05-05	71-E633-05-05

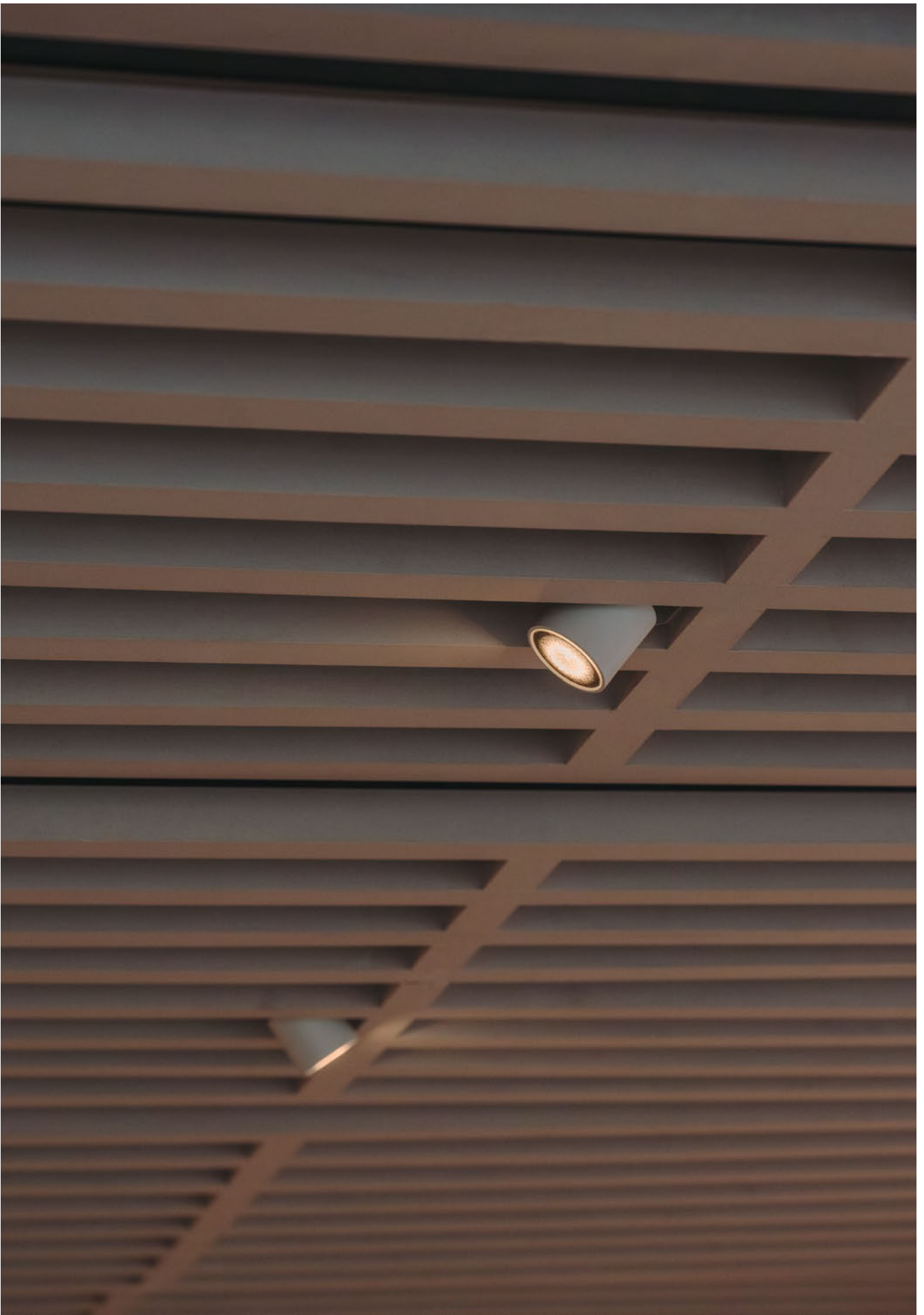

Max Medium in Fiske Bar Barcelona project. Photography: Salva López.
Max Medium en projet, Fiske Bar Barcelona. Photographie : Salva López

Eko

Designed by LedsC4 Architectural



Downlight
P. 608



Bollard
P. 744

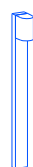

Wall Fixtures
P. 794



Ceiling
P. 856



The most complete essential GU10 collection La collection essentielle GU10 la plus complète

This collection is perfect for projects seeking an affordable, highly reliable solution for various applications. It's notable for the versatility of its models, options and features, along with its easy installation and maintenance.

Cette collection est idéale pour les projets qui recherchent une solution abordable et fiable afin de répondre à des applications diverses. Elle se distingue par la polyvalence des modèles, des options et des prestations, ainsi que par sa facilité d'installation et d'entretien.

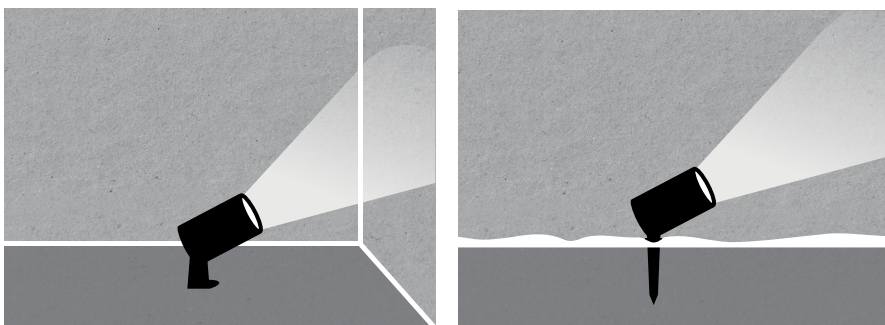

14

34

DL

E3

J6

Z5

60





Eko Spotlight

IP
65

IK
07

BODY MAT
AL

DIF MAT
PC



1 m

SEA SIDE
SUITABLE

180°

● ● ● ● ● ● ● ●
60 Z5* 14* 34* J6* E3* DL*

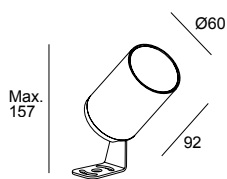

GU10
W
Code
60
Z5
J6
Max. 8
05-E155 - E3 - 37
DL
14
34

Connection accessories

Accessoires de connexion

	IP68 connector (1 input + 1 output) Ø 5.5–11.5 mm, 4 poles Connecteur IP68 (1 entrée + 1 sortie) Ø 5,5 - 11,5 mm 4 pôles	71-E512-00-00
	IP68 connector (1 input + 2 outputs) Ø 5.5–11.5 mm, 3 poles Connecteur IP68 (1 entrée + 2 sorties) Ø 5,5 - 11,5 mm, 3 pôles	71-E513-00-00
	IP68 anti-condensation connector (1 input + 1 output) Ø 5.5–12 mm, 4 poles Connecteur anticondensation IP68 (1 entrée + 3 sorties) Ø 5,5 - 12 mm, 4 pôles	71-E122-00-00
	Conector anticondensación IP68 (1 entrada + 3 salidas) Ø 5,5 - 12mm, 4 polos Conetor anticondensação IP68 (1 entrada + 3 saídas) Ø 5,5 - 12 mm, 4 polos	71-E112-00-00

Fixing accessories

Accessoires de fixation

	235mm spiked post Piquet de 235 mm	71-9997-05-05
	302mm spiked post Piquet de 302 mm	71-9998-05-05

Repair accessories

Accessoires de réparation

	Bulb extraction kit (suction cup + clamp) Kit d'extraction de l'ampoule (ventouse + pince)	71-E634-00-00
--	-----------------------------------------------------------------------------------------------	---------------

* Please contact our sales team for conditions and delivery times.

* Consultez notre équipe commerciale pour connaître les conditions et les délais de livraison.

Modis

Designed by Luca Turrini



+ Modis

Wall Fixture
P. 782

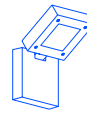

Ceiling
P. 862



Bollard
P. 706

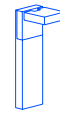

Lampost
P. 706



OUTDOOR



Total ease of movement Liberté totale de mouvement

The Modis spotlight directs the light beam towards the object being lit, offering superior precision and uniformity thanks to the rotation of its head to enhance both the vegetation and the architecture of the environment in which it is installed.

Le projecteur Modis dirige le faisceau de lumière vers l'objet à éclairer avec précision, grâce à la rotation de sa tête, et de manière très uniforme, réhaussant à la fois la végétation et l'architecture environnante.

SPOTLIGHTS | PROJECTEURS



14



34

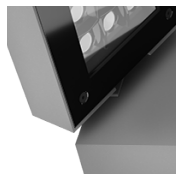

DL



E3

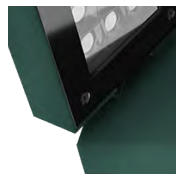

J6



Z5



60





BODY MAT	DIF MAT		50000h	3
AL	GLA		L80 B20	MacAdam

Modis Opal Single

IP	IK	SWITCH CCT		SEA SIDE SUITABLE				
66	10	2700-3200-4000			180°	350°		

Z5 14* 60* 34* J6* E3* DL*

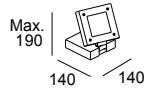
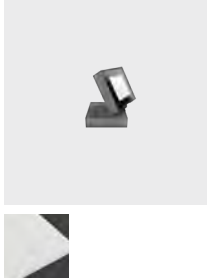

LED						
K	CRI	W Total	Real Lm	Code		
				Z5		
				J6		
				E3	OU	ON-OFF 100-277V
2700-3200-4000	80	13.2	744	05-E062 - DL - DU		DALI-2 100-277V
				14	XB	CASAMBI 220-240V
				60		
				34		

The indicated flux corresponds to the core temperature.
Le flux indiqué correspond à la température centrale.

Modis Opal Double 430mm

IP	IK	BREEAM	SWITCH CCT		SEA SIDE SUITABLE				
66	10		2700-3200-4000			180°	350°		

Z5 14* 60* 34* J6* E3* DL*

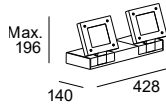

LED						
K	CRI	W Total	Real Lm	Code		
				Z5		
				J6		
				E3	OU	ON-OFF 100-277V
2700-3200-4000	80	2 × 26.4	1488	05-E063 - DL - DU		DALI-2 100-277V
				14	XB	CASAMBI 220-240V
				60		
				34		

The indicated flux corresponds to the core temperature.
Le flux indiqué correspond à la température centrale.

Modis Opal Double 800mm

IP	IK	BREEAM	SWITCH CCT		SEA SIDE SUITABLE				
66	10		2700-3200-4000			350°	180°		

Z5 14* 60* 34* J6* E3* DL*

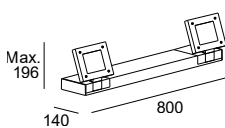

LED						
K	CRI	W Total	Real Lm	Code		
				Z5		
				J6		
				E3	OU	ON-OFF 100-277V
2700-3200-4000	80	2 × 26.4	1488	05-E064 - DL - DU		DALI-2 100-277V
				14	XB	CASAMBI 220-240V
				60		
				34		

The indicated flux corresponds to the core temperature.
Le flux indiqué correspond à la température centrale.

Modis Optics Single

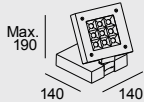

Code example / Exemple d'élaboration d'une référence: **AS11-18V9S30UZ5**

Model	W	K	CRI	Real Lm	Optics	Source	Finishes
AS11 - Single ↻350° ↻180° 	18P8	18.3	2200	80	932-1062	S3 16° OU ON-OFF 220-240V	Z5 14* 60* 34* J6* E3* DL*
	18V9	18.3	2700	90	1680-1914	M3 38° DS DALI-2/PUSH 220-240V	
	18W9	18.3	3000	90	1680-1914	F1 48° XB CASAMBI 220-240V	
	18X9	18.3	4000	90	1826-2080		

Modis Optics Double 430mm

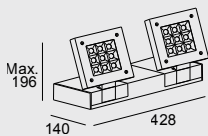

Code example / Exemple d'élaboration d'une référence: **AS12-37V9S30UZ5**

Model	W	K	CRI	Real Lm	Optics	Source	Finishes
AS12 - Double 430mm ↻350° ↻180° 	37P8	2 × 18.3	2200	80	1864-3652	S3 16° OU ON-OFF 220-240V	Z5 14* 60* 34* J6* E3* DL*
	37V9	2 × 18.3	2700	90	3360-3828	M3 38° DS DALI-2/PUSH 220-240V	
	37W9	2 × 18.3	3000	90	3360-3828	F1 48° XB CASAMBI 220-240V	
	37X9	2 × 18.3	4000	90	3652-4160		

Modis Optics Double 800mm

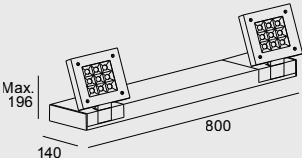

Code example / Exemple d'élaboration d'une référence: **AS13-37V9S30UZ5**

Model	W	K	CRI	Real Lm	Optics	Source	Finishes
AS13 - Double 800mm ↻350° ↻180° 	37P8	2 × 18.3	2200	80	1864-3652	S3 16° OU ON-OFF 220-240V	Z5 14* 60* 34* J6* E3* DL*
	37V9	2 × 18.3	2700	90	3360-3828	M3 38° DS DALI-2/PUSH 220-240V	
	37W9	2 × 18.3	3000	90	3360-3828	F1 48° XB CASAMBI 220-240V	
	37X9	2 × 18.3	4000	90	3652-4160		

* Please contact our sales team for conditions and delivery times.

* Consultez notre équipe commerciale pour connaître les conditions et les délais de livraison.

Lens accessories
Accessoires optiques

Visor
Visière

Z5 ●	71-E234-Z5-00	14 ○ *	71-E234-14-00
J6 ● *	71-E234-J6-00	60 ● *	71-E234-60-00
E3 ● *	71-E234-E3-00	34 ○ *	71-E234-34-00
DL ● *	71-E234-DL-00		

Fixing accessories
Accessoires de fixation

235mm spiked post
Piquet de 235 mm
Only for single

- **71-9997-05-05**

Joint accessories
Accessoires de raccord

Interlinking plate
Plaque d'enchaînement
Not for single

Z5 ●	71-E235-Z5-00	14 ○ *	71-E235-14-00
J6 ● *	71-E235-J6-00	60 ● *	71-E235-60-00
E3 ● *	71-E235-E3-00	34 ○ *	71-E235-34-00
DL ● *	71-E235-DL-00		

Hubble

Designed by Francesc Vilaró



+ Hubble

Maximum versatility Polyvalence maximale

The variety of materials, light sources and multiple accessories make Hubble the most versatile collection in the catalogue. Designed to illuminate diverse settings, from private gardens to large public areas, as it can reach up to 10,000 real lumens.

La variété de matériaux, de sources lumineuses et d'accessoires font de Hubble la collection la plus polyvalente du catalogue. Conçue pour éclairer des jardins privés jusqu'aux grandes zones d'usage public car elle peut atteindre jusqu'à 10 000 lumens réels.



Installations Installations

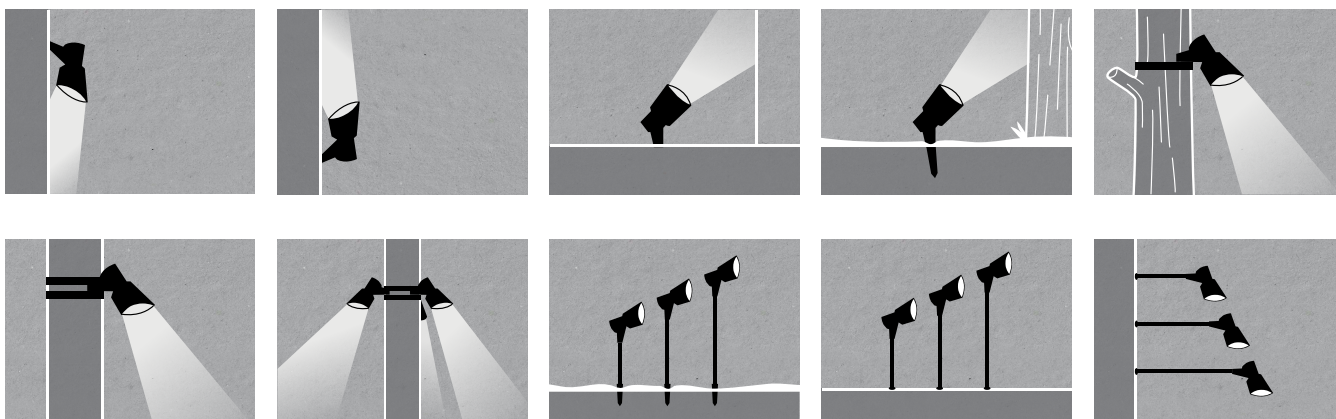

**Hubble
Cob**
560

Highly versatile LED solution
Solution LED très polyvalente

Ø 126 mm



●
Z5

**Hubble GU10
Aluminium**
565

Ideal GU10 solution for rigid and
visible surfaces
Solution GU10 idéale pour surfaces
rigides et exposées

Ø 120 mm



○ ● ●
14 Z5 34

**Hubble GU10
Technopolymer**
566

Ideal GU10 solution for embedding
in lawn
Solution GU10 idéale pour une
installation avec piquet sur gazon

Ø 120 mm



●
05

Ø 175 mm



●
Z5

Ø 207 mm



●
Z5

Ø 234 mm



●
Z5

11.5 - 92 W



S - F

S: Spot (18°) **F:** Flood (34°)

Hubble Cob



Highly versatile LED solution
Solution LED hautement polyvalente

Light effects Effets de lumière



With 11° reflector
Avec réflecteur de 11°



With 38° reflector
Avec réflecteur de 38°

11°-16° reflector
Réflecteur 11°-16°

38°-39° reflector
Réflecteur 38°-39°

Anti-glare
Anti-éblouissement

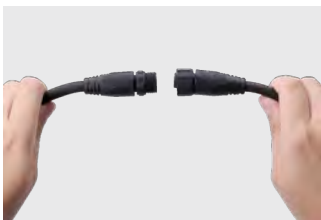

Includes wiring with quick and sealed connection for easy and safe installation. (Hubble Cob)
Comprend le câblage avec connexion rapide et étanche pour une installation facile et sûre. (Hubble Cob)



Hubble Cob 175mm in Son Rich Residences project in Begur. Photography: Jordi Anguera.
Hubble Cob 175 mm en projet, Son Rich Residences de Begur. Photographie : Jordi Anguera.

Hubble Cob 126mm

BODY MAT	DIF MAT		50000h	IP	IK	BREEAM	3		SEA SIDE SUITABLE			
ALU	GLA		L80 B20	65	7	MacAdam	±90°					

Z5

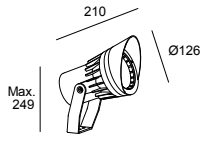

LED							
K	CRI	W Total	Real Lm	Optics	Code		
2700	80	13	1167	11°;38°	05-9989 - Z5 - CK	ON-OFF 100-240V	
3000	80	13	1167	11°;38°	05-9989 - Z5 - CL	ON-OFF 100-240V	
4000	80	13	1251	11°;38°	05-9989 - Z5 - CM	ON-OFF 100-240V	

Hubble Cob 175mm

BODY MAT	DIF MAT		50000h	IP	IK	BREEAM	3		SEA SIDE SUITABLE			
ALU	GLA		L80 B20	65	8	MacAdam	±90°					

Z5

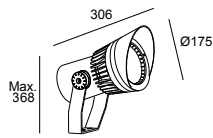

LED							
K	CRI	W Total	Real Lm	Optics	Code		
2700	80	35.2	3589	16°;39°	05-E101 - Z5 - CK	ON-OFF 220-240V	
3000	80	35.2	3589	16°;39°	05-E101 - Z5 - CL	ON-OFF 220-240V	
4000	80	35.2	3804	16°;39°	05-E101 - Z5 - CM	ON-OFF 220-240V	

Hubble Cob 207mm

BODY MAT	DIF MAT		50000h	IP	IK	BREEAM	3		SEA SIDE SUITABLE			
ALU	GLA		L80 B20	65	8	MacAdam	±90°					

Z5

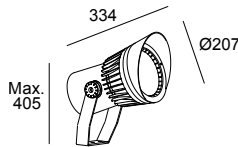

LED							
K	CRI	W Total	Real Lm	Optics	Code		
2700	80	56.4	5266	16°, 39°	05-E166 - Z5 - CK	DALI-2 220-240V	
3000	80	56.4	5631	16°, 39°	05-E166 - Z5 - CL	DALI-2 220-240V	
4000	80	56.4	5631	16°, 39°	05-E166 - Z5 - CM	DALI-2 220-240V	

Hubble Cob 234mm

BODY MAT	DIF MAT		50000h	IP	IK	LOW FLICKER	BREEAM			SEA SIDE SUITABLE		
ALU	GLA		L80 B20	66	9	MacAdam	±90°					



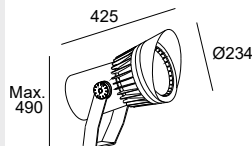
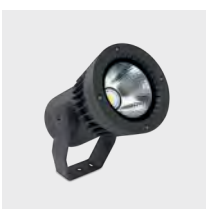

Z5



LED							
K	CRI	W Total	Real Lm	Optics	Code		
2700	80	96.8	9931	16°, 39°	05-E083 - Z5 - CK	DALI-2 220-240V	
3000	80	96.8	10552	16°, 39°	05-E083 - Z5 - CL	DALI-2 220-240V	
4000	80	96.8	10863	16°, 39°	05-E083 - Z5 - CM	DALI-2 220-240V	

Hubble Cob 126mm	Hubble Cob 175mm	Hubble Cob 207mm	Hubble Cob 234mm
			

Connection accessories
Accessoires de connexion

	220V DALI-2 Cable with waterproof tongue and groove connectors (1 m) Câble DALI-2 220V avec connecteurs étanches mâle-femelle (1 m)	-	-	71-E440-05-05	71-E440-05-05
	220V DALI-2 Cable with waterproof tongue and groove connectors (5 m) Câble DALI-2 220V avec connecteurs étanches mâle-femelle (5 m)	-	-	71-E429-05-05	71-E429-05-05
	T connector 5 poles DALI-2 Connecteur T 5 pôles DALI-2	-	-	71-E548-05-05	71-E548-05-05
	220V cable with waterproof tongue and groove connectors (1 m) Câble 220 V à connecteurs étanches mâle-femelle (1 m)	71-E438-05-05	71-E438-05-05	-	-
	220V cable with waterproof tongue and groove connectors (5 m) Câble 220 V à connecteurs étanches mâle-femelle (5 m)	71-E428-05-05	71-E428-05-05	-	-
	T connector 3 poles Connecteur T 3 pôles	71-E547-05-05	71-E547-05-05	-	-

Lens accessories
Accessoires optiques







	Anti-glare Anti-éblouissement	Included	Included	Included	-
	Visor Visière	Included	Included	Included	Included
	Set of 2 reflectors (11° and 38°) Set de 2 réflecteurs (11° et 38°)	Included	-	-	-
	Set of 2 reflectors (16° and 39°) Set de 2 réflecteurs (16° et 39°)	-	Included	Included	Included

Connective controllers
Contrôleurs connectés

P. 969

 **Consult the available control systems / Consultez les systèmes de contrôle disponibles:**
 DALI2 / DALI2
 Bluetooth wireless / Sans fil Bluetooth
 Autonomous / Autonome

Hubble Cob
126mmHubble Cob
175mmHubble Cob
207mmHubble Cob
234mm**Fixing accessories****Accessoires de fixation**

	235mm spiked post Piquet de 235 mm	71-9997-05-05	71-9997-05-05	71-9997-05-05	71-9997-05-05
	302mm spiked post Piquet de 302 mm	71-9998-05-05	71-9998-05-05	71-9998-05-05	71-9998-05-05
	Mount for columns Fixation pour mâts	-	-	71-E058-Z5-00	71-E058-Z5-00
	Mount for columns or trees Fixation pour mâts ou arbres	71-9999-Z5-Z5	71-9999-Z5-Z5	-	-
	Attachment (max. 3 spotlights) Fixation (3 projecteurs maxi.)	71-9746-05-05	-	-	-
	Wall, floor and lawn extender (300/500/800mm) Rallonge pour mur, sol et gazon (300/500/800 mm)	71-E052-Z5-Z5	71-E052-Z5-Z5	-	-
	Base for Ø6mm - Ø13.5mm cables Base pour câbles de Ø6 mm - Ø13,5 mm	71-E016-Z5-Z5	71-E016-Z5-Z5	71-E016-Z5-Z5	71-E016-Z5-Z5

Hubble GU10 Aluminium



GU10 solution, ideal for visible rigid surfaces
Solution GU10 idéale pour les surfaces rigides apparentes



Hubble GU10 Aluminium

BODY MAT	DIF MAT			IP	IK	SEA SIDE	
ALU	GLA			65	6	SUITABLE	

● ○ ●
Z5 14 34

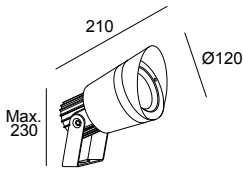

GU10	Code
W	Z5
Max. 8	05-9416 - 14 - 37
	34

Lens accessories

Accessoires optiques



Visor
Visière

Included

Fixing accessories

Accessoires de fixation



302mm spiked post
Piquet de 302 mm

71-9998-05-05



235mm spiked post
Piquet de 235 mm

71-9997-05-05



Mount for columns or trees
Fixation pour mâts ou arbres

71-9999-Z5-Z5



Attachment (max. 3 spotlights)
Fixation (3 projecteurs maxi.)

71-9746-05-05



Wall, floor and lawn extender (300/500/800mm)
Rallonge pour mur, sol et gazon (300/500/800 mm)

Z5 ●

71-E052-Z5-Z5

34 ●

71-E052-34-34



Base for Ø6mm - Ø13.5mm cables
Base pour câbles de Ø6 mm - Ø13,5 mm

71-E016-Z5-Z5

Hubble GU10 Technopolymer



GU10 solution, ideal
for nailing in a lawn
Solution GU10 idéale
à enfoncer dans la pelouse

Suitable for perpetually damp areas or low-voltage
installations.

Indiquée pour les zones en permanence humides ou
les installations à basse tension.

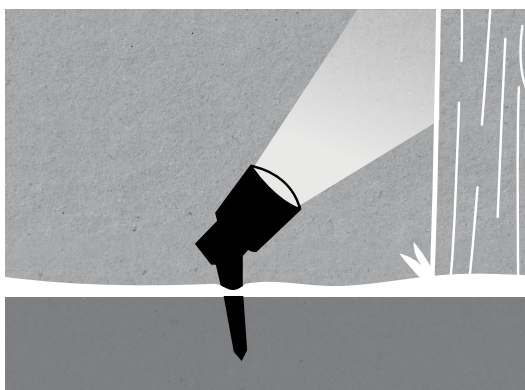

Installation using a
stake is feasible
Possibilité d'installation
avec piquet

Made of 100%
ultra-resistant
techno-polymer
100 % fabriquée en
technopolymère
ultra résistant



**Hubble GU10&GU5.3
Technopolymer**

BODY MAT	DIF MAT		IP	IK	SEA SIDE	
POLI	GLA		66	6	SUITABLE	

05

OUTDOOR

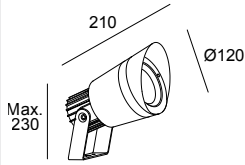

GU10	
W	Code
Max. 8	05-9722 - 05 - 37

**Lens accessories
Accessoires optiques**



Visor
Visière

Included



GU5.3 + GU10 lamp holders
Douilles GU5.3 + GU10

Included

**Fixing accessories
Accessoires de fixation**



Spiked post
Piquet

Included



302mm spiked post
Piquet de 302 mm

71-9998-05-05



235mm spiked post
Piquet de 235 mm

71-9997-05-05



Mount for columns or trees
Fixation pour mâts ou arbres

71-9999-Z5-Z5



Attachment (max. 3 spotlights)
Fixation (3 projecteurs maxi.)

71-9746-05-05



Base for Ø6mm - Ø13.5mm cables
Base pour câbles de Ø6 mm - Ø13,5 mm

71-E016-Z5-Z5

SPOTLIGHTS | PROJECTEURS

Thor

Designed by LedsC4 Architectural



+ Thor



Exciting by night.
Spectacular by day
Riche en émotions la nuit.
Spectaculaire le jour

The purity of stainless steel offers an imposing appearance, which can be seen with the naked eye during the day and sensed at night. Thor enhances the splendour of night-time settings with dimmable and controlled lighting and blends into daytime scenes thanks to its detailed, pure silhouette.

La pureté de l'acier inoxydable offre un port indiscutable, qui s'apprécie à l'œil nu le jour et se ressent la nuit. Thor rehausse la majesté des espaces nocturnes avec un éclairage réglable et contrôlé et s'intègre dans l'environnement de jour grâce à une ligne épurée, travaillée dans les moindres détails.

Ø72 mm



Ø50 mm



Ø26 mm



Lenses Optiques

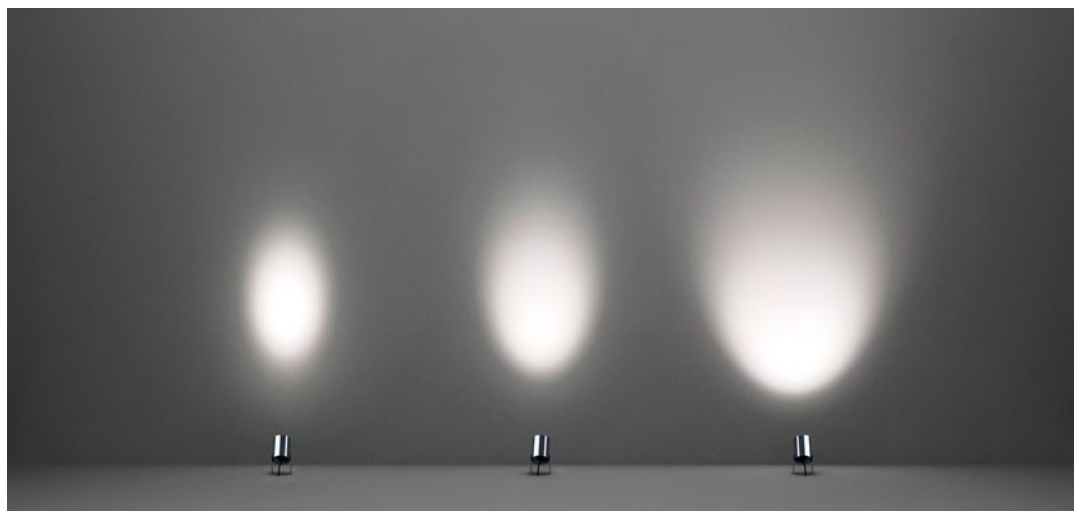

14° (05-E009-CA-CL)/26° (05-E153-CA-CL)/ 49° (05-E010-CA-CL)



Thor Ø26	BODY MAT AISI316	DIF MAT GLA		50000h L80 B20	2 MacAdam	IP 66	IK 02		BREEAM		SEA SIDE SUITABLE			
-----------------	---------------------	----------------	--	-------------------	--------------	----------	----------	--	--------	--	----------------------	--	--	--

CA

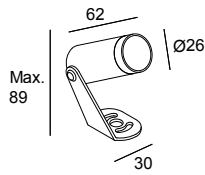

LED						24-48 VDC
K	CRI	W	Real Lm	Optics	Code	
3000	80	2	154	19°	05-E007	
3000	80	2	138	33°	05-E152 - CA - CL	
3000	80	2	169	52°	05-E008	

Thor Ø50	BODY MAT AISI316	DIF MAT GLA		50000h L80 B20	2 MacAdam	IP 66	IK 02		BREEAM		SEA SIDE SUITABLE			
-----------------	---------------------	----------------	--	-------------------	--------------	----------	----------	--	--------	--	----------------------	--	--	--

CA

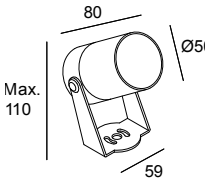

LED						24-48 VDC
K	CRI	W	Real Lm	Optics	Code	
3000	80	4.5	290	14°	05-E009	
3000	80	4.5	352	26°	05-E153 - CA - CL	
3000	80	4.5	341	48°	05-E010	

Thor Ø72	BODY MAT AISI316	DIF MAT GLA		50000h L80 B20	2 MacAdam	IP 66	IK 05		BREEAM		SEA SIDE SUITABLE			
-----------------	---------------------	----------------	--	-------------------	--------------	----------	----------	--	--------	--	----------------------	--	--	--

CA

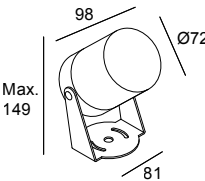

LED						24VDC
K	CRI	W	Real Lm	Optics	Code	
3000	80	8.4	758	16°	05-E011	
3000	80	8.4	812	29°	05-E154 - CA - CL	
3000	80	8.4	675	52°	05-E013	

	Thor Ø26	Thor Ø50	Thor Ø72
Power supplies Sources d'alimentation			P. 985
	ON-OFF IP20	Max. 20W	71-B650-00-00
		Max. 30W	71-B640-00-00
		Max. 100W	71-B641-00-00
	ON-OFF IP67	Max. 100W	71-B646-00-00
		Max. 60W	71-B645-00-00
			71-B644-00-00 Max. 30W
			71-B642-00-00 Max. 150W
	DALI2 IP20	Max. 150W	71-B653-00-00
		Max. 60W	71-B652-00-00
	DALI2 IP67	Max. 160W	71-B656-00-00
		Max. 60W	71-B655-00-00
		Max. 240W	71-B675-00-00



Thor Ø26

Thor Ø50

Thor Ø72



Fixing accessories
Accessoires de fixation

	Spiked post Piquet	71-E143-05-05	71-E143-05-05	-
	302mm spiked post Piquet de 302 mm	-	-	71-9998-05-05
	235mm spiked post Piquet de 235 mm	-	-	71-9997-05-05

Connection accessories
Accessoires de connexion

	IP67 connector (1 input + 1 output) Ø 5,5 - 7,5mm, 3 poles Connecteur IP67 (1 entrée + 1 sortie) Ø 5,5 - 7,5 mm, 3 pôles	71-E510-00-00	71-E510-00-00	71-E510-00-00
	IP67 connector (1 input + 2 output) Ø 5,5 - 7,5mm, 3 poles Connecteur IP67 (1 entrée + 2 sortie) Ø 5,5 - 7,5 mm, 3 pôles	71-E511-00-00	71-E511-00-00	71-E511-00-00
	IP68 connector (1 input + 1 output) Ø 5.5–11.5 mm, 4 poles Connecteur IP68 (1 entrée + 1 sortie) Ø 5,5 - 11,5 mm, 4 pôles	71-E512-00-00	71-E512-00-00	71-E512-00-00
	IP68 connector (1 input + 2 outputs) Ø 5.5–11.5 mm, 3 poles Connecteur IP68 (1 entrée + 2 sorties) Ø 5,5 - 11,5 mm, 3 pôles	71-E513-00-00	71-E513-00-00	71-E513-00-00
	IP68 anti-condensation connector (1 input + 1 output) Ø 5.5–12 mm, 4 poles Connecteur anticondensation IP68 (1 entrée + 1 sortie) Ø 5,5 - 12 mm, 4 pôles	71-E112-00-00	71-E112-00-00	71-E112-00-00
	IP68 anti-condensation connector (1 input + 3 outputs) Ø 5.5–12 mm, 4 poles Connecteur anticondensation IP68 (1 entrée + 3 sorties) Ø 5,5 - 12 mm, 4 pôles	71-E122-00-00	71-E122-00-00	71-E122-00-00
	IP67 connection box (1 input + 2 outputs) Ø 6–7.5 mm, 3 poles Boîtier de raccordement IP67 (1 entrée + 2 sorties) Ø 6 - 7,5 mm, 3 pôles	71-9262-05-05	71-9262-05-05	71-9262-05-05
	IP68 connection box (1 input + 5 outputs) Ø 6.5–11 mm, 6 poles Boîtier de raccordement IP67 (1 entrée + 5 sorties) Ø 6,5 - 11 mm, 6 pôles	71-9199-05-05	71-9199-05-05	71-9199-05-05

Connective controllers
Contrôleurs connectés

P. 969



Consult the available control systems / Consultez les systèmes de contrôle disponibles:
DALI2 / DALI2
Bluetooth wireless / Sans fil Bluetooth
DMX / DMX
Autonomous / Autonome

Micro

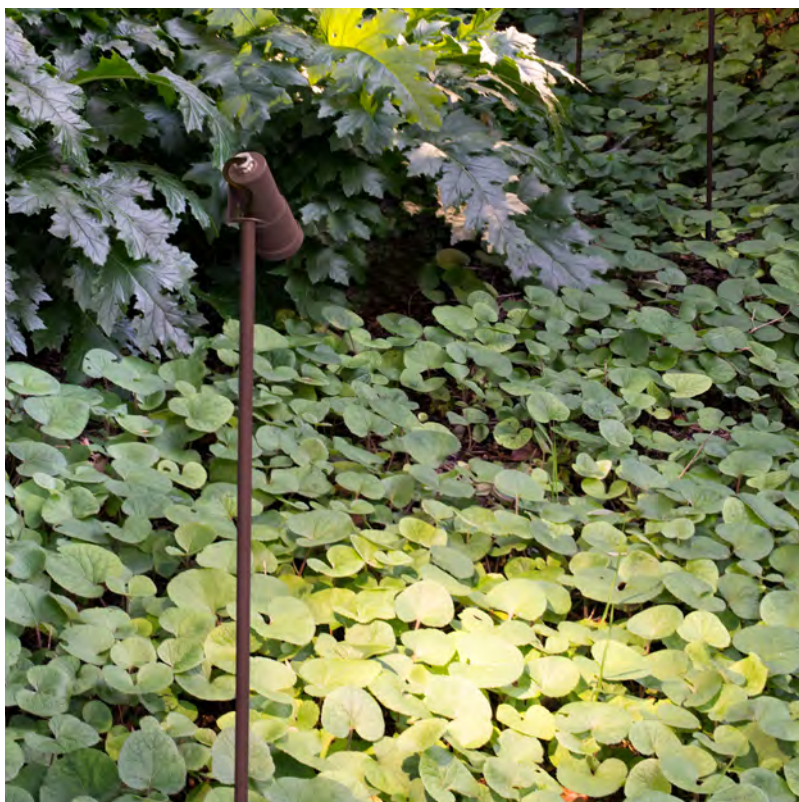

Lighting integrated into bushes

Éclairage intégré à la végétation

A good landscaping project should always be completed with adequate lighting that rises to the challenge of integration in plants and bushes. Micro provides warm and controlled lighting for all types of low-height vegetation. Un bon projet d'aménagement paysager doit être complété par un éclairage adapté qui relève le défi de l'intégration aux plantes et aux arbustes. Micro est la solution idéale pour éclairer chaleureusement et de façon contrôlée toutes sortes de végétation de faible hauteur.



Installations Installations

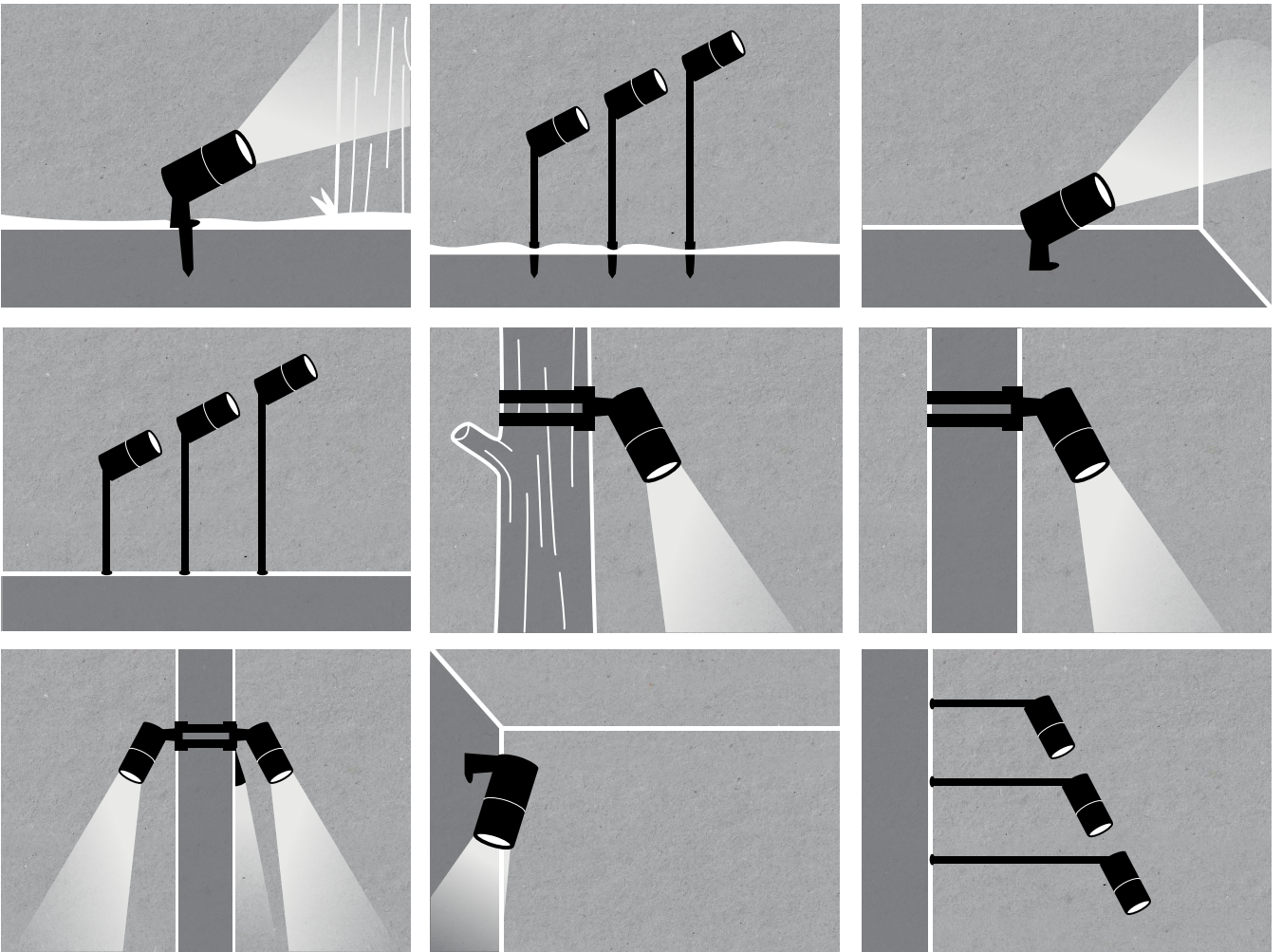

Lens accessories included Accessoires optiques inclus



Visor
Visière



15° reflector
Réflecteur 15°



Green filter
Filtre vert



Yellow filter
Filtre jaune



Diffuser filter
Filtre diffuseur



24°-38° reflector
Réflecteur 24°-38°

Micro Ø57mm

BODY MAT	DIF MAT		50000h	2	IP	IK	LOW	BREEAM		SEA SIDE	
AL	GLA		L80 B20	MacAdam	66	04	FLICKER	2.5 m	SUITABLE	±90°	

● ●
Z5 J6

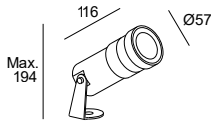

LED										
K	CRI	W Total	Real Lm	Optics	Code					
3000	80	4.7	343	15°;24°	05-9881 - Z5 - CL		ON-OFF 100-240V			
						J6				



Micro Ø70mm

BODY MAT	DIF MAT		50000h	2	IP	IK	LOW	BREEAM		SEA SIDE	
AL	GLA		L80 B20	MacAdam	66	04	FLICKER	2.5 m	SUITABLE	±90°	

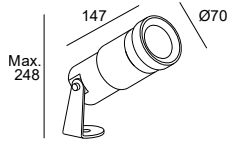



● ●
Z5 J6







LED										
K	CRI	W Total	Real Lm	Optics	Code					
3000	80	7.5	643	15°;38°	05-9988 - Z5 - CL		ON-OFF 100-240V			
						J6				

	Micro Ø57mm	Micro Ø70mm
		







Lens accessories
Accessoires optiques

	Diffuser filter Filtre diffuseur	Included	Included
	Visor Visière	Included	Included
	Set of 2 filters (green and yellow) Set de 2 filtres (vert et jaune)	Included	Included
	Set of 2 reflectors (18° and 51°) Set de 2 réflecteurs (18° et 51°)	Included 15°, 24°	Included 15°, 38°

Fixing accessories
Accessoires de fixation

	Spiked post Piquet	Included	Included
	Mount for columns or trees Fixation pour mâts ou arbres	71-9999-Z5-Z5	71-9999-Z5-Z5
	Attachment (max. 3 spotlights) Fixation (3 projecteurs maxi.)	71-9746-05-05	71-9746-05-05
	Wall, floor and lawn extender (300/500/800mm) Rallonge pour mur, sol et gazon (300/500/800 mm)	Z5 ● 71-E052-Z5-Z5	71-E052-Z5-Z5
		J6 ● 71-E052-J6-J6	71-E052-J6-J6

Connection accessories
Accessoires de connexion

	IP68 connector (1 input + 1 output) Ø 5.5–11.5 mm, 4 poles Connecteur IP68 (1 entrée + 1 sortie) Ø 5,5 - 11,5 mm, 4 pôles	71-E512-00-00	71-E512-00-00
	IP68 connector (1 input + 2 outputs) Ø 5.5–11.5 mm, 3 poles Connecteur IP68 (1 entrée + 2 sorties) Ø 5,5 - 11,5 mm, 3 pôles	71-E513-00-00	71-E513-00-00
	IP68 anti-condensation connector (1 input + 1 output) Ø 5.5–12 mm, 4 poles Connecteur anticondensation IP68 (1 entrée + 1 sortie) Ø 5,5 - 12 mm, 4 pôles	71-E112-00-00	71-E112-00-00
	IP68 anti-condensation connector (1 input + 3 outputs) Ø 5.5–12 mm, 4 poles Connecteur anticondensation IP68 (1 entrée + 3 sorties) Ø 5,5 - 12 mm, 4 pôles	71-E122-00-00	71-E122-00-00
	IP67 connection box (1 input + 2 outputs) Ø 6–7.5 mm, 3 poles Boîtier de raccordement IP67 (1 entrée + 2 sorties) Ø 6 - 7,5 mm, 3 pôles	71-9262-05-05	71-9262-05-05
	IP68 connection box (1 input + 5 outputs) Ø 6.5–11 mm, 6 poles Boîtier de raccordement IP67 (1 entrée + 5 sorties) Ø 6,5 - 11 mm, 6 pôles	71-9199-05-05	71-9199-05-05

Zoom



+ Zoom



Adaptable to vegetation growth Adaptable à la croissance de la végétation

The Zoom luminaires allow you to adjust the light beam quickly, manually and without the need for tools. This proves particularly useful both for adapting to the natural growth of vegetation and for projects in which the desired light effect is chosen during installation.
Les luminaires Zoom permettent de régler le faisceau lumineux rapidement, manuellement et sans outils, ce qui est très utile tant pour s'adapter à la croissance naturelle de la végétation que pour les projets où l'effet lumineux souhaité est choisi lors de l'installation.



Base kit for semi-buried application
Kit de socle pour application semi-enterrée



Base kit for surface application
Kit de socle pour application de surface





Adjustable opening angle thanks to a manual zoom system, which does not require any tools
Angle d'ouverture réglable grâce à un système de zoom manuel sans nécessité d'outils

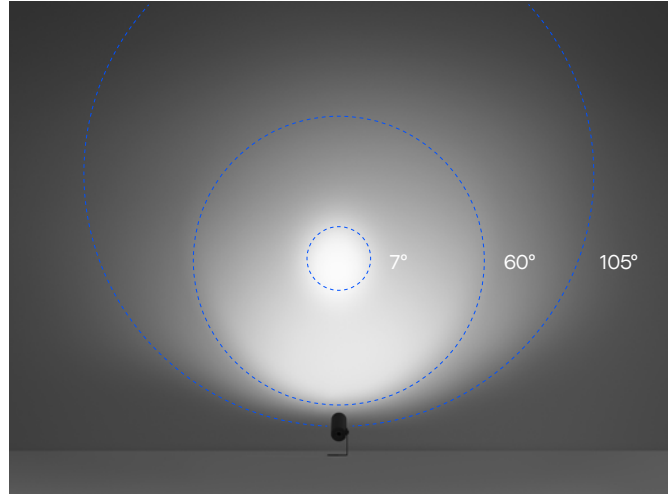

Head with magnifier for moving from Spot to Medium angle
Tête avec verre grossissant pour passer de l'angle Spot à Medium



Magnifierless head for moving from Medium to Flood angle
Tête sans verre grossissant pour passer de l'angle Medium à Flood



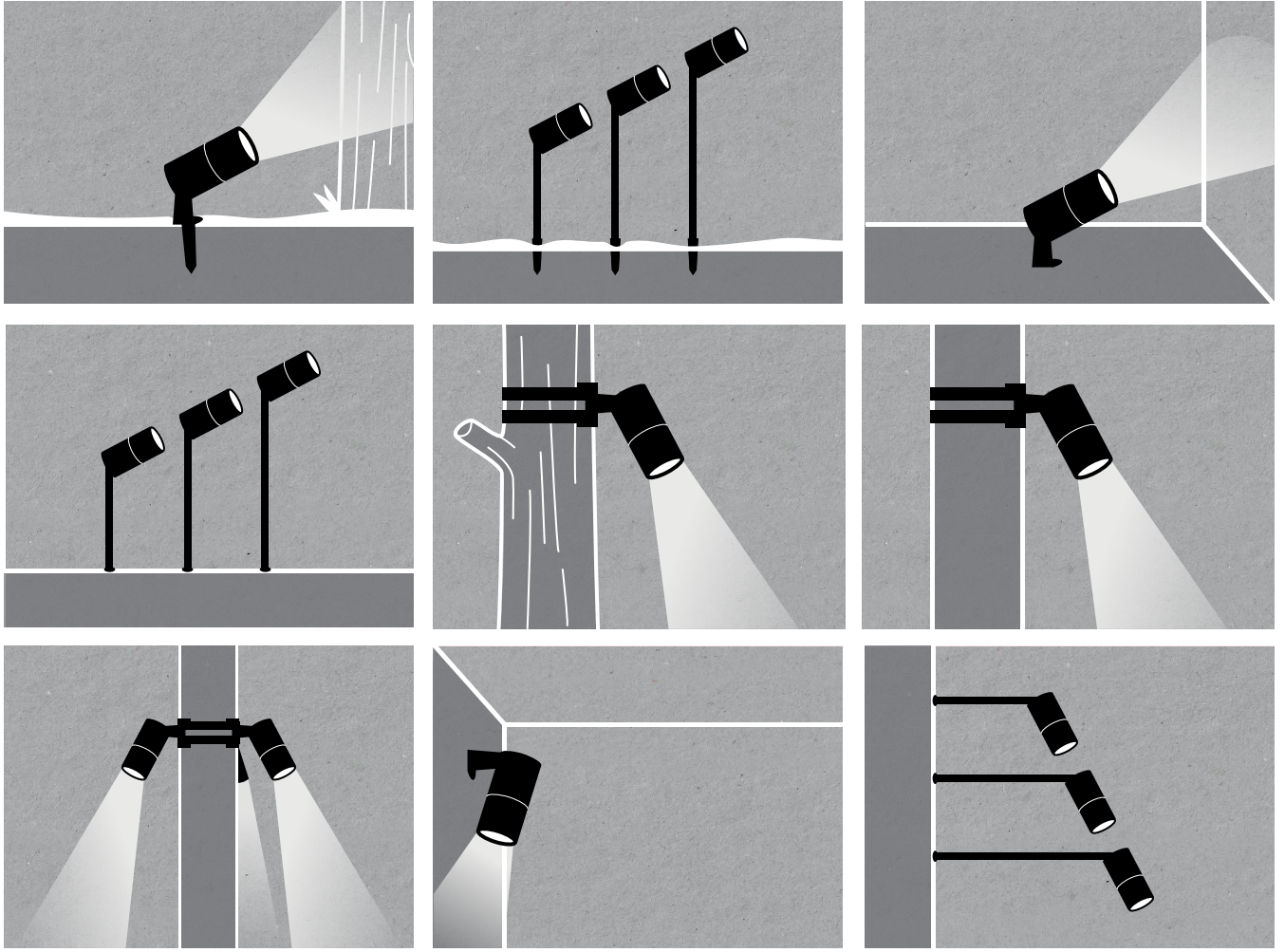

**Zoom
3.8W**

BODY MAT
AL

DIF MAT
PMMA



50000h
L80 B20

3
MacAdam

IP
66

IK
10

BREEAM

- +
DIM

0.2 m

SEA SIDE SUITABLE

±90°



●
05

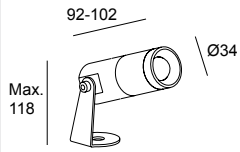

LED						max.1200mA 3V
K	CRI	W	Real Lm	Optics	Code	
2700	80	3.8	270	Zoom 7°- 105°	05-E060 - 05 - CK	
3000	80	3.8	270	Zoom 7°- 105°	05-E060 - 05 - CL	

**Zoom
8.4W**

BODY MAT
AL

DIF MAT
PMMA



50000h
L80 B20

3
MacAdam

IP
66

IK
10

BREEAM

- +
DIM

0.2 m

SEA SIDE SUITABLE





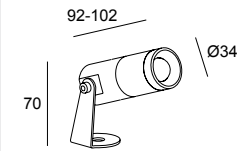

±90°



●
05







LED						max.700mA 12V
K	CRI	W	Real Lm	Optics	Code	
2700	80	8.4	428	Zoom 7°- 105°	05-E061 - 05 - CK	
3000	80	8.4	428	Zoom 7°- 105°	05-E061 - 05 - CL	

		Zoom 3.8W	Zoom 8.4W
Drivers			
Driver			
	ON-OFF IP20	71-4914-00-00 Min.1 - Max.13	71-3542-00-00 Min.1 - Max.5
		-	71-B232-00-00 
	ON-OFF IP68	-	71-E014-00-00
	1-10V DALI2 IP68	71-E518-00-00 Min.4 - Max.15	71-E086-00-00 Min.1 - Max.4
	DALI2 PUSH IP20	-	71-A190-00-00
	Spiked post with ON-OFF driver Piquet avec driver ON-OFF	71-E225-05-05	71-E226-05-05

Lens accessories Accessoires optiques

	Visor Visière	Included	Included
------------------------------------------------------------------------------------	------------------	----------	----------

Fixing accessories Accessoires de fixation

	235mm spiked post Piquet de 235 mm	71-9997-05-05	71-9997-05-05
	302mm spiked post Piquet de 302 mm	71-9998-05-05	71-9998-05-05
	Mount for columns or trees Fixation pour mâts ou arbres	71-9999-Z5-Z5	71-9999-Z5-Z5
	Attachment (max. 3 spotlights) Fixation (3 projecteurs maxi.)	71-9746-05-05	71-9746-05-05
	Wall, floor and lawn extender (300/500/800mm) Rallonge pour mur, sol et gazon (300/500/800 mm)	71-E052-Z5-Z5	71-E052-Z5-Z5

Connection accessories Accessoires de connexion

	IP67 connector (1 input + 1 output) Ø 5,5 - 7,5mm, 3 poles Connecteur IP67 (1 entrée + 1 sortie) Ø 5,5 - 7,5 mm, 3 pôles	71-E510-00-00	71-E510-00-00
	P68 connector (1 input + 1 output) Ø 5.5–11.5 mm, 4 poles Connecteur IP68 (1 entrée + 1 sortie) Ø 5,5 - 11,5 mm, 4 pôles	71-E512-00-00	71-E512-00-00
	IP68 anti-condensation connector (1 input + 1 output) Ø 5.5–12 mm, 4 poles Connecteur anticondensation IP68 (1 entrée + 1 sortie) Ø 5,5 - 12 mm, 4 pôles	71-E112-00-00	71-E112-00-00



Trustworthy accent lighting Éclairage d'accentuation fidèle

Suv has been designed for those spaces requiring trustworthy and functional accent lighting. Driver included inside the luminaire. Includes wiring with quick and sealed connection for easy and safe installation.

Éclairage d'accentuation fidèle. Driver inclus à l'intérieur du luminaire. Comprend le câblage avec connexion rapide et étanche pour une installation facile et sûre

Suv 61mm

BODY MAT	DIF MAT		2	IP	IK	BREEAM		SEA SIDE SUITABLE			
AL	GLA		MacAdam	65	6				±90°		

Z5

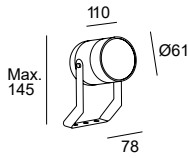

LED							
K	CRI	W Total	Real Lm	Optics	Code		
3000	80	5.5	434	22°	05-E046 - Z5 - CL	ON-OFF	100-220V

Suv 80mm

BODY MAT	DIF MAT		2	NEW	IP	IK		SEA SIDE SUITABLE			
AL	GLA		MacAdam		65	6			±90°		

Z5

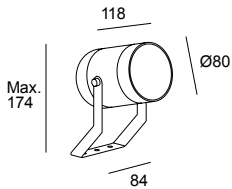

LED							
K	CRI	W Total	Real Lm	Optics	Code		
3000	80	13.5	1294	29°	05-E057 - Z5 - CL	ON-OFF	100-220V

Fixing accessories

Accessoires de fixation



Spiked post
Piquet

Included

Connection accessories

Accessoires de connexion



Extension 1000 mm
Rallonge 1 000 mm

71-E438-00-00

Extension 5000 mm
Rallonge 5 000 mm

71-E428-00-00



T connector
Connecteur en T

71-E547-05-05

Reliability with traditional light bulbs Fiabilité avec des ampoules traditionnelles

Helio is a collection of luminaires for spaces in which there is no need for constant lighting or a very high luminous flux. Using traditional light bulbs, this solution provides reliable and quality lighting.

Helio est une collection de luminaires destinés aux espaces qui n'exigent pas d'éclairage constant ni de flux lumineux très élevé. À base d'ampoules traditionnelles, cette solution assure un éclairage fiable et de qualité.

Helio AISI 316 GU10

BODY MAT	DIF MAT		IP	IK	SEA SIDE		
AISI 316	GLA		66	10	SUITABLE	360°	±45°

CA

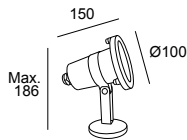
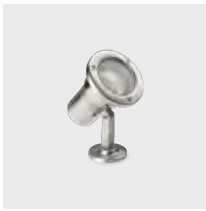

GU10

W	Code
Max. 8	05-9310 - CA - 37

Helio Aluminium GU10

BODY MAT	DIF MAT		IP	IK	SEA SIDE	
AL	GLA		65	10	SUITABLE	±90°

05 34

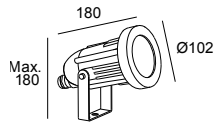

GU10

W	Code
Max. 8	05-9640 - 34 - 37
	05

Helio Aluminium E27

BODY MAT	DIF MAT		IP	IK		SEA SIDE	
AL	GLA		65	6	2.5 m	SUITABLE	±90°

Z5

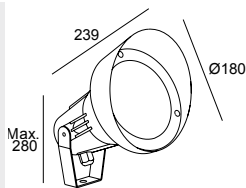

E27

W	Code
Max. 15	05-9789 - Z5 - 37

Fixing accessories Accessoires de fixation



Spiked post
Piquet

Included



Mount for columns or trees
Fixation pour mâts ou arbres

71-9999-Z5-Z5



Attachment (max. 3 spotlights)
Fixation (3 projecteurs maxi.)

71-9746-05-05



Wall, floor and lawn extender (300/500/800mm)
Rallonge pour mur, sol et gazon (300/500/800 mm)

Z5

71-E052-Z5-Z5

34

71-E052-34-34



Base for Ø6mm - Ø13.5mm cables
Base pour câbles de Ø6 mm - Ø13,5 mm

71-E016-Z5-Z5

Underwater Submersibles

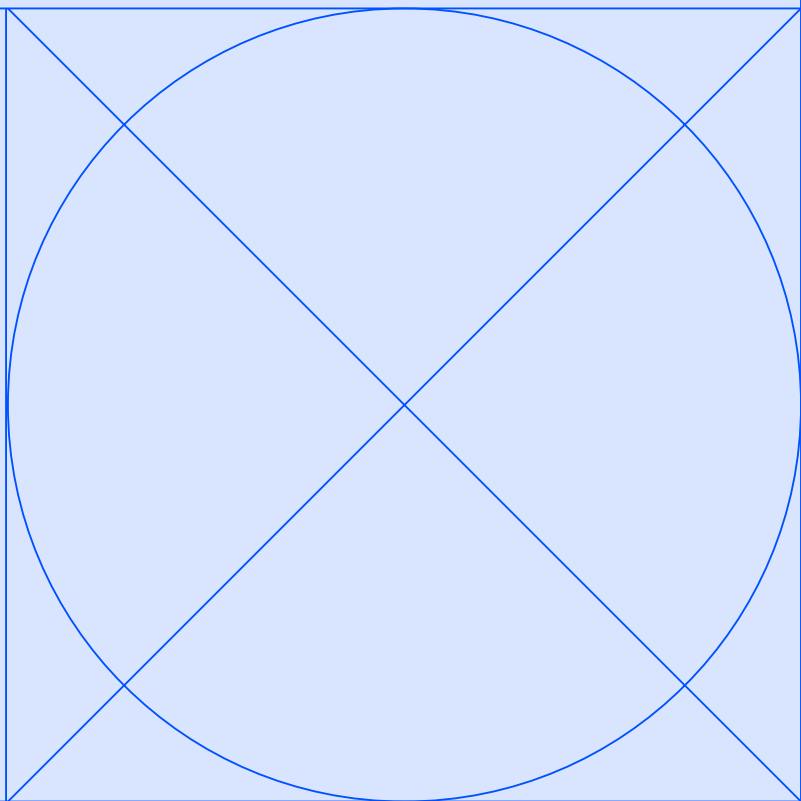

Aro
586



Aqua
594

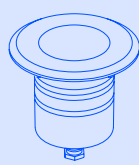



+ Aro



Submersible with a broad range of lighting options Immergeable avec une large gamme d'options d'éclairage

Submersible spotlights and recessed fixtures designed to deliver dependable illumination and optical precision. Aro is the sole collection in its category that offers a wide array of options enabling enhanced lighting control, including lenses, colour temperatures and dimming regulations.

Luminaires encastrés et projecteurs submersibles conçus pour éclairer en toute fiabilité et avec précision optique. Aro est la seule collection de sa catégorie à offrir une vaste gamme d'options qui permettent un contrôle lumineux accru, notamment grâce à ses modules optiques, températures de couleur et possibilités de gradation.

Ø100 mm



Ø59 mm



Ø33 mm



Ø100 mm



Ø75 mm



Ø45 mm





Symetrical



Symetrical + Honeycomb



Opal



Wallwasher

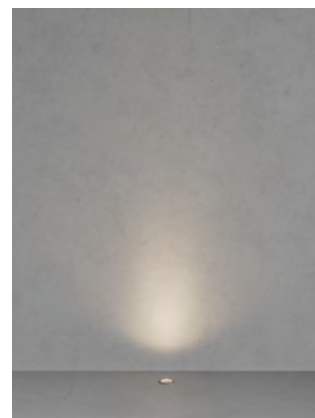

Lenses to modulate the light
Optiques permettant de
moduler la lumière

Replaceable in case of damage
Remplaçable en cas de panne



STOP-WATER system
Système STOP-WATER

The STOP-WATER system prevents the ingress of water and air, ensuring an extended lifespan.

Le système STOP-WATER empêche l'entrée d'eau et d'air, assurant une plus longue durée de vie.

Aro

- ① **Body, frame and screws made entirely from AISI316 stainless steel.**
Corps, cadre et visserie fabriqués à 100 % en acier inoxydable AISI316.
- ② **Anti-vandalism screws to deter tampering with the luminaire.**
Visserie anti-vandalisme permettant d'éviter la manipulation du luminaire.
- ③ **Special anti-opening cable gland for waterproofing assurance.**
Presse-étoupes anti-ouverture assurant l'étanchéité.
- ④ **Neoprene cable for improved luminaire reliability and user-friendliness.**
Câble en néoprène permettant de faciliter et de maximiser la fiabilité du luminaire.
- ⑤ **Customisable lens module.**
Module optique personnalisable.
- ⑥ **Includes an internal STOP-WATER system.**
Système STOP-WATER interne fourni.

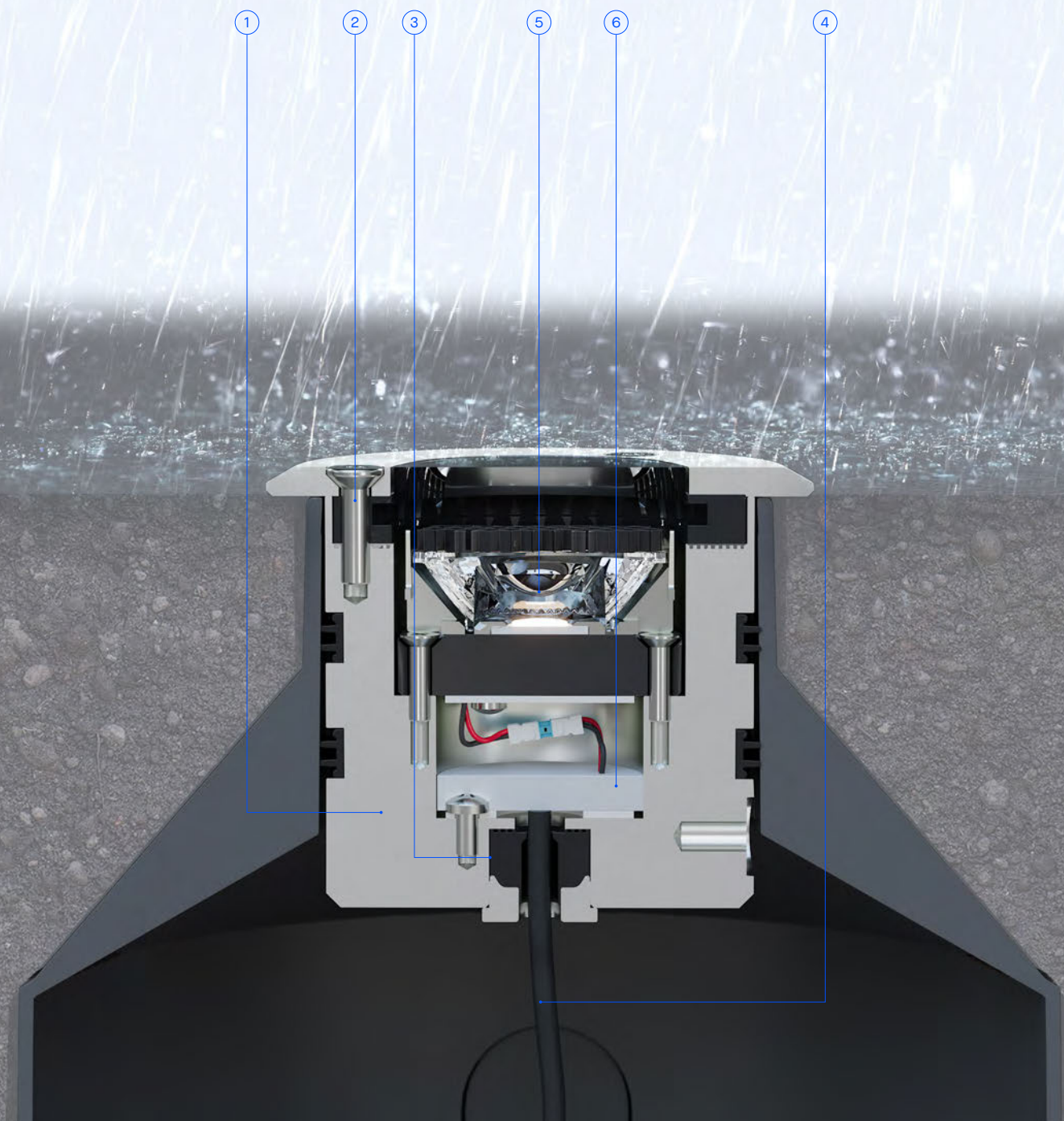

Aro Small Ø45

BODY MAT
INOX 316

DIF MAT
GLA



50000h
L80 B20

2
MacAdam

IP
66-68 5m

IK
10

2 m

PWM

SEA SIDE
SUITABLE



Code example / Exemple d'élaboration d'une référence: **BJ14-P3V9S3BBCA**

Model		W	K	CRI	Optics	Real Lm	Source	Finishes
BJ14 - Ø45mm 	P3V9	2.7	2700	90	S3 19°	101-109	BB 24VDC PWM	CA
	P3W9	2.7	3000	90	M3 34°	118-127		
	P3X9	2.7	4000	90	F2 50°	87-94		
					T3 19° Honeycomb incl.	72-78		
					K3 28° Honeycomb incl.	76-83		
					N2 40° Honeycomb incl.	54-58		
					PL Opal	71-76		

Aro Medium Ø75

BODY MAT
INOX 316

DIF MAT
GLA



50000h
L80 B20

2
MacAdam

IP
66-68 5m

IK
10

2 m

SEA SIDE
SUITABLE



Code example / Exemple d'élaboration d'une référence: **BJ15-PSV9S3BBCA**

Model		W	K	CRI	Optics	Real Lm	Source	Finishes
BJ15 - Ø75mm 	P6V9	6.1	2700	90	S3 15°	386-444	BB 24VDC PWM	CA
	P6W9	6.1	3000	90	M3 36°	393-452		
	P6X9	6.1	4000	90	F2 62°	400-460		
					T3 18° Honeycomb incl.	239-275		
					K3 31° Honeycomb incl.	253-292		
					N2 62° Honeycomb incl.	386-444		
					PL Opal	286-329		
				R2 Wallwasher	305-351			

Aro Big Ø100

BODY MAT
INOX 316

DIF MAT
GLA



50000h
L80 B20

2
MacAdam

IP
66-68 5m

IK
10

2 m

SEA SIDE
SUITABLE





Code example / Exemple d'élaboration d'une référence: **BJ16-12V9S2BBCA**



Model		W	K	CRI	Optics	Real Lm	Source	Finishes
BJ16 - Ø100mm 	12V9	13.2	2700	90	S2 14°	1034-1190	BB 24VDC PWM	CA
	12W9	13.2	3000	90	M3 38°	1050-1209		
	12X9	13.2	4000	90	F2 62°	1114-1281		
					T2 14° Honeycomb incl.	717-825		
					K3 33° Honeycomb incl.	690-794		
					N2 47° Honeycomb incl.	612-704		
					PL Opal	858-987		
				R2 Wallwasher	897-1032			

Power supplies

P. 985



Sources d'alimentation

	ON-OFF IP20	Max. 75W	71-A258-00-00		DALI2 IP20	Max. 60W	71-B663-00-00
		Max. 120W	71-A259-00-00			Max. 100W	71-B664-00-00
	ON-OFF IP20	Max. 100W	71-B641-00-00				
		Max. 160W	71-B642-00-00				
		Max. 400W	71-B643-00-00				
		Max. 600W	71-B643-00-00				

	Aro Small	Aro Medium	Aro Large
			

Fixing accessories

Accessoires de fixation

	Recess case Boîtier d'encastrement	71-E418-00-00	71-E139-00-00	71-E264-00-00
	Submersible recess case Boîtier d'encastrement submersible	71-E627-00-00	71-E628-00-00	71-E629-00-00

Connection accessories

Accessoires de connexion

	IP68 connector (1 input + 1 output) Ø 5.5–11.5 mm, 4 poles Connecteur IP68 (1 entrée + 1 sortie) Ø 5,5 - 11,5 mm, 4 pôles	71-E512-00-00	71-E512-00-00	71-E512-00-00
	IP68 connector (1 input + 2 outputs) Ø 5.5–11.5 mm, 3 poles Connecteur IP68 (1 entrée + 2 sorties) Ø 5,5 - 11,5 mm, 3 pôles	71-E513-00-00	71-E513-00-00	71-E513-00-00
	IP68 anti-condensation connector (1 input + 1 output) Ø 5.5–12 mm, 4 poles Connecteur anticondensation IP68 (1 entrée + 1 sortie) Ø 5,5 - 12 mm, 4 pôles	71-E112-00-00	71-E112-00-00	71-E112-00-00
	IP68 anti-condensation connector (1 input + 3 outputs) Ø 5.5–12 mm, 4 poles Connecteur anticondensation IP68 (1 entrée + 3 sorties) Ø 5,5 - 12 mm, 4 pôles	71-E122-00-00	71-E122-00-00	71-E122-00-00

**Aro Small
Ø45**

BODY MAT INOX 316	DIF MAT GLA		50000h L80 B20	2 MacAdam	IP 66-68 5m	 180°	IK 10	 2 m			
----------------------	----------------	--	-------------------	--------------	-------------------	----------	----------	---------	--	--	--

Code example / Exemple d'élaboration d'une référence: **BJ11-P3V9S3BBCA**

Model		W	K	CRI	Optics	Lm	Source	Finishes
BJ11 - Ø33mm 	P3V9	2.7	2700	90	S3 19°	101-109	BB 24VDC PWM	CA
	P3W9	2.7	3000	90	M3 34°	118-127		
	P3X9	2.7	4000	90	F2 50°	87-94		
					T3 19° Honeycomb incl.	72-78		
					K3 28° Honeycomb incl.	76-83		
					N2 40° Honeycomb incl.	54-58		
					PL Opal	71-76		

**Aro Medium
Ø75**

BODY MAT INOX 316	DIF MAT GLA		50000h L80 B20	2 MacAdam	IP 66-68 5m	 180°	IK 10	 2 m			
----------------------	----------------	--	-------------------	--------------	-------------------	----------	----------	---------	--	--	--

Code example / Exemple d'élaboration d'une référence: **BJ12-P3V9S3BBCA**

Model		W	K	CRI	Optics	Lm	Source	Finishes
BJ12 - Ø59mm 	P6V9	6.1	2700	90	S3 15°	386-444	BB 24VDC PWM	CA
	P6W9	6.1	3000	90	M3 36°	393-452		
	P6X9	6.1	4000	90	F2 62°	400-460		
					T3 18° Honeycomb incl.	239-275		
					K3 31° Honeycomb incl.	253-292		
					N2 62° Honeycomb incl.	386-444		
					PL Opal	286-329		

**Aro Big
Ø85**

BODY MAT INOX 316	DIF MAT GLA		50000h L80 B20	2 MacAdam	IP 66-68 5m	 180°	IK 10	 2 m			
----------------------	----------------	--	-------------------	--------------	-------------------	----------	----------	---------	--	--	--



Code example / Exemple d'élaboration d'une référence: **BJ13-P3V9S3BBCA**

Model		W	K	CRI	Optics	Lm	Source	Finishes
BJ13 - Ø85mm 	12V9	13.2	2700	90	S2 14°	1034-1190	BB 24VDC PWM	CA
	12W9	13.2	3000	90	M3 38°	1050-1209		
	12X9	13.2	4000	90	F2 62°	1114-1281		
					T2 14° Honeycomb incl.	717-825		
					K3 33° Honeycomb incl.	690-794		
					N2 47° Honeycomb incl.	612-704		
					PL Opal	858-987		

Power supplies

P. 985

Sources d'alimentation

	ON-OFF IP20	Max. 75W	71-A258-00-00		DALI2 IP20	Max. 60W	71-B663-00-00
		Max. 120W	71-A259-00-00			Max. 100W	71-B664-00-00
	ON-OFF IP20	Max. 100W	71-B660-00-00				
		Max. 160W	71-B661-00-00				
		Max. 400W	71-B678-00-00				
		Max. 600W	71-B079-00-00				

Aro Small



Aro Medium





Aro Large



Fixing accessories

Accessoires de fixation

	235mm spiked post Piquet de 235 mm	-	71-9997-05-05	71-9997-05-05
		-	71-9998-05-05	71-9998-05-05
	302mm spiked post Piquet de 302 mm	-	71-9998-05-05	71-9998-05-05
		71-E143-05-05	-	-
	Spiked post Piquet	71-E143-05-05	-	-

Connection accessories

Accessoires de connexion

	IP68 connector (1 input + 1 output) Ø 5.5-11.5 mm, 4 poles Connecteur IP68 (1 entrée + 1 sortie) Ø 5,5 - 11,5 mm, 4 pôles	71-E512-00-00	71-E512-00-00	71-E512-00-00
		71-E513-00-00	71-E513-00-00	71-E513-00-00
	IP68 connector (1 input + 2 outputs) Ø 5.5-11.5 mm, 3 poles Connecteur IP68 (1 entrée + 2 sorties) Ø 5,5 - 11,5 mm, 3 pôles	71-E112-00-00	71-E112-00-00	71-E112-00-00
		71-E122-00-00	71-E122-00-00	71-E122-00-00
	IP68 anti-condensation connector (1 input + 1 output) Ø 5.5-12 mm, 4 poles Connecteur anticondensation IP68 (1 entrée + 1 sortie) Ø 5,5 - 12 mm, 4 pôles	71-E112-00-00	71-E112-00-00	71-E112-00-00
		71-E122-00-00	71-E122-00-00	71-E122-00-00
	IP68 anti-condensation connector (1 input + 3 outputs) Ø 5.5-12 mm, 4 poles Connecteur anticondensation IP68 (1 entrée + 3 sorties) Ø 5,5 - 12 mm, 4 pôles	71-E112-00-00	71-E112-00-00	71-E112-00-00
		71-E122-00-00	71-E122-00-00	71-E122-00-00

Submersible solution Solution submersible

Aqua is the ideal choice for projects requiring a quality submersible solution. Made with AISI316 stainless steel, Aqua offers additional resistance for coastal environments.

Dans les projets qui exigent un submersible de qualité réalisé en acier inoxydable AISI316, le modèle Aqua est la solution idéale car il offre un plus de résistance en milieu marin.

Aqua Spotlight AISI 316 LED

BODY MAT AISI316	DIF MAT GLA		50000h L80 B20	IP 68	IK 10	BREEAM	3 MacAdam	 2.5 m		 360°	 ±45°	
---------------------	----------------	--	-------------------	----------	----------	--------	--------------	-----------	--	----------	----------	--

CA

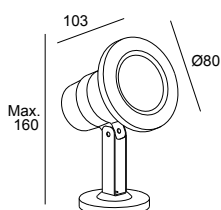
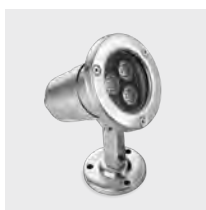

LED						12V AC/DC
K	CRI	W	Real Lm	Optics	Code	
4000	90	5	311	24°	05-9889 - CA - CM	

P. 1000

Aqua Spotlight AISI 316 GU5.3

BODY MAT AISI316	DIF MAT GLA	IP 68	IK 10	BREEAM	 2.5 m		 360°	 ±45°
---------------------	----------------	----------	----------	--------	-----------	--	----------	----------

CA

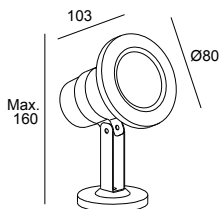

GU5.3						Code
W						05-9245 - CA - 37
Max. 5						

Aqua Recessed AISI 316 LED

BODY MAT AISI316	DIF MAT GLA		50000h L80 B20	IP 68	IK 08	BREEAM	3 MacAdam	 1000 Kg	 5 m		
---------------------	----------------	--	-------------------	----------	----------	--------	--------------	-------------	---------	--	--

CA

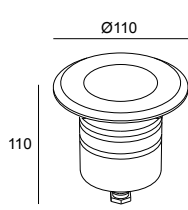

LED						12V AC/DC
K	CRI	W	Real Lm	Optics	Code	
4000	80	5	313	24°	55-9792 - CA - CM	

Aqua Recessed AISI 316 GU5.3

BODY MAT AISI316	DIF MAT GLA	IP 68	IK 08	BREEAM	 1000 Kg	 5 m	
---------------------	----------------	----------	----------	--------	-------------	---------	--

CA

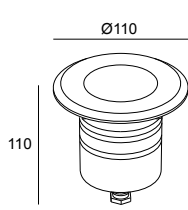

GU5.3						Code
W						55-9245 - CA - 37
Max. 5						

Aqua Spotlight LED

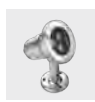

Aqua Spotlight GU5.3



Aqua Recessed LED



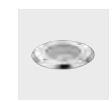

Aqua Recessed GU5.3





Power supplies
Sources d'alimentation





P. 985

	ON-OFF IP20	71-B677-00-00 Max. 20W	-	71-B677-00-00 Max. 20W	-
	ON-OFF IP67	71-B676-00-00 Max. 96W	-	71-B676-00-00 Max. 96W	-

Fixing accessories
Accessoires de fixation

	Spiked post Piquet	Included	Included	-	-
	Recess case Boîtier d'encastrement	-	-	Included	Included

Connection accessories
Accessoires de connexion

	IP68 connector (1 input + 1 output) Ø 5.5–11.5 mm, 4 poles Connecteur IP68 (1 entrée + 1 sortie) Ø 5,5 - 11,5 mm, 4 pôles	71-E512-00-00	71-E512-00-00	71-E512-00-00	71-E512-00-00
	IP68 connector (1 input + 2 outputs) Ø 5.5–11.5 mm, 3 poles Connecteur IP68 (1 entrée + 2 sorties) Ø 5,5 - 11,5 mm, 3 pôles	71-E513-00-00	71-E513-00-00	71-E513-00-00	71-E513-00-00
	IP68 anti-condensation connector (1 input + 1 output) Ø 5.5–12 mm, 4 poles Connecteur anticondensation IP68 (1 entrée + 1 sortie) Ø 5,5 - 12 mm, 4 pôles	71-E112-00-00	71-E112-00-00	71-E112-00-00	71-E112-00-00
	IP68 anti-condensation connector (1 input + 3 outputs) Ø 5.5–12 mm, 4 poles Connecteur anticondensation IP68 (1 entrée + 3 sorties) Ø 5,5 - 12 mm, 4 pôles	71-E122-00-00	71-E122-00-00	71-E122-00-00	71-E122-00-00
	IP68 connection box (1 input + 5 outputs) Ø 6.5–11 mm, 6 poles Boîtier de raccordement IP67 (1 entrée + 5 sorties) Ø 6,5 - 11 mm, 6 pôles	71-9199-05-05	71-9199-05-05	71-9199-05-05	71-9199-05-05

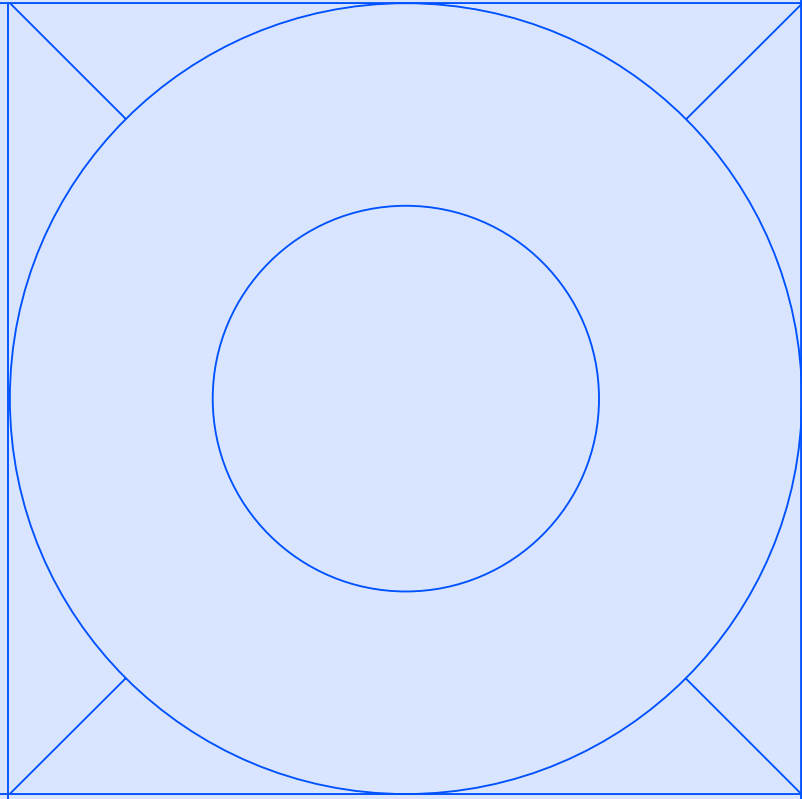

Recessed downlights

Encastrés de plafond

Max
598

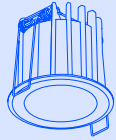

Dako
604

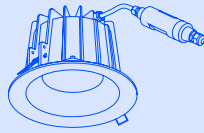

Eko
608

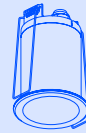

Gea
610

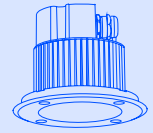

Max

Designed by LedsC4 Architectural



+ Max

Bollard
P. 738



Wall Fixture
P. 788

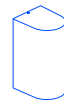

Ceiling
P. 852



Spotlight
P. 540



Uplight
P. 630



Excellent light control Excellent contrôle lumineux

The aim of the Max recessed ceiling lights is to offer maximum control. To achieve this, it uses a wide range of options: lenses, outputs, adjustment features, colour temperatures, finishes and lens accessories. By combining these options, total control of the light is achieved to adapt it to all situations and needs. Le but des encastrés de plafond Max est d'offrir un maximum de contrôle. Pour cela, ils s'appuient sur un vaste éventail d'options : lentilles, puissances, variations, températures de couleur, finitions et accessoires optiques. En combinant ces options, on obtient un contrôle total de la lumière pour répondre à toutes les situations et à tous les besoins.



Stainless steel (CA)
Acier inoxydable (CA)



Gold brass (17)
Laiton doré (17)



Brushed chrome (18)
Chrome poli (18)



New metallic finishes Nouvelles finitions métalliques

14



34



DL



E3

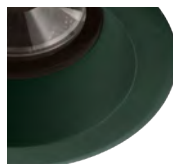

J6



Z5



60





Excellent visual
comfort
Excellent confort
visuel



OUTDOOR

RECESSED DOWNLIGHTS | ENCASTRES DE PLAFOND

Max Mini Downlight

BODY MAT AL	DIF MAT GLA		50000h L80 B20	2 MacAdam	IP 66	IK 04	 1 m	 DIM	 SEA SIDE SUITABLE	
----------------	----------------	--	-------------------	--------------	----------	----------	---------	---------	--------------------------	--

Code example / Exemple d'élaboration d'une référence: **BA14-P2P8S1BBZ5**

Model	W	K	CRI	Optics	Real Lm	Source	Finishes	
BA14 - Ø47mm Round ≙ 45 mm ≙ 40 55 Ø47 	Constant Current 700mA							
	P2P8	2.5	2200	80	S1 10°	152 - 163	BB 3V/max.700mA	14*
	P2V8	2.2	2700	80	S2 15°	172 - 185		34*
	P2W8	2.2	3000	80	M3 32°	178 - 191		60*
	P2X8	2.2	4000	80	F2 53°	147 - 158		CA DL* E3* I7 I8 J6* Z5
BA15 - 47mm Square ≙ 45 mm ≙ 40 55 47 47 	Constant Voltage 24V							
	P3V8	2.5	2700	80	S3 19°	94	BB 24VDC PWM	J6*
	P3W8	2.5	3000	80	M3 32°	97		Z5
	P3X8	2.5	4000	80	F2 51°	87		
BA16 - Ø58mm Round UGR ≙ 20 mm ≙ 47 44 Ø58 								

Max Medium Downlight

BODY MAT AL	DIF MAT GLA		50000h L80 B20	2 MacAdam	IP 66	IK 10	UGR <19	 1 m	 DIM	 SEA SIDE SUITABLE	
----------------	----------------	--	-------------------	--------------	----------	----------	------------	---------	---------	--------------------------	--

Code example / Exemple d'élaboration d'une référence: **AI14-P4V9S1BBZ5**

Model	W	K	CRI	Optics	Real Lm	Source	Finishes	
AI14 - Ø75mm Round ≙ 0-50 mm ≙ 65 70 Ø75 	Constant Current 350mA							
	P4V9	4	2700	80	S1 9°	286	BB 12V/max.350mA	14*
	P4W9	4	3000	80				34*
	P4X9	4	4000	80				60*
AI15 - Ø75mm Square ≙ 0-50 mm ≙ 65 70 75 75 								
	P7P8	6.5	2200	80	S2 17°	519	BB 18V/max.350mA	CA DL* E3*
	P7V9	6.5	2700	90	M2 27°	459		I7 I8
	P7W9	6.5	3000	90	F1 50°	423		J6* Z5
AI16 - Ø100mm Round UGR ≙ 0-30 mm ≙ 85 80 Ø100 	Constant Voltage 24V							
	P6V9	6	2700	90	S1 9°	204	BB 24VDC PWM	
	P6W9	6	3000	90				
	P6X9	6	4000	90				
	P8V9	7.9	2700	90	S2 17°	519	BB 24VDC PWM	
	P8W9	7.9	3000	90	M2 27°	459		
P8X9	7.9	4000	90	F1 50°	423			

* Please contact our sales team for conditions and delivery times.
 * Consultez notre équipe commerciale pour connaître les conditions et les délais de livraison.

Max Big Downlight

BODY MAT
AL

DIF MAT
GLA



50000h
L80 B20

2
MacAdam

IP
66

IK
10

UGR
<19











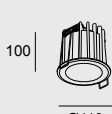

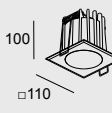

1 m

DIM

SEA SIDE
SUITABLE



Code example / Exemple d'élaboration d'une référence: **AT14-18V9S3BBZ5**

Model	W	K	CRI	Optics	Real Lm	Source	Finishes	
AT14 - Ø75mm Round 0-70 mm 95 	Constant Current							
	13V9	13.7	2700	90	S1 10°	931-1054	BB  12V/max.350mA	14* 
	13W9	13.7	3000	90				34* 
	13X9	13.7	4000	90				60* 
	18P8	17.3	2200	80	S3 21°	1844-2126	BB  18V/max.350mA	CA 
AT15 - Ø75mm Square 0-70 mm 95 							DL* 	
	18V9	17.3	2700	90	M2 31°	1902-2191		E3* 
	18W9	17.3	3000	90	F2 40°	1565-1812		I7 
	18X9	17.3	4000	90				I8 
								J6* 
AT16 - Ø100mm Round UGR 0-25 mm 125 	Constant Voltage 24V						Z5 	
	14V9	13.8	2700	90	S3 16°	1086	BB  24VDC PWM	
	14W9	13.8	3000	90	M2 28°	1076		
	14X9	13.8	4000	90	F2 51°	1120		

OUTDOOR

RECESSED DOWNLIGHTS | ENCASTRÉS DE PLAFOND





* Please contact our sales team for conditions and delivery times.
 * Consultez notre équipe commerciale pour connaître les conditions et les délais de livraison.

Constant Voltage 24V

Power supplies

P. 985

Sources d'alimentation

	ON-OFF IP20	Max.20W	71-B650-00-00		DALI2 IP20	Max.60W	71-B652-00-00
		Max.30W	71-B640-00-00			Max.150W	71-B653-00-00
		Max.100W	71-B641-00-00			Max.250W	71-B654-00-00
		Max.150W	71-B642-00-00				DALI2 IP67
Max.250W	71-B643-00-00	Max.160W	71-B656-00-00				
	ON-OFF IP67	Max.30W	71-B644-00-00			Max.240W	71-B675-00-00
		Max.60W	71-B645-00-00				
		Max.100W	71-B646-00-00				
		Max.160W	71-B647-00-00				
		Max.240W	71-B648-00-00				

Constant Current



Drivers

P. 984

Drivers

	ON-OFF IP20	71-B682-00-00 ✎	71-A652-00-00 ✎	71-6652-00-00 ✎	71-6652-00-00 ✎	71-7551-00-00 ✎
				Min.2 - Max.2		
		71-3542-00-00 ✎	71-3542-00-00 ✎	71-3542-00-00 ✎	-	-
		Min.1 - Max.22	Min.1 - Max.6	Min.1 - Max.3		
	ON-OFF IP68	71-E014-00-00	71-E079-00-00 ✎	71-E079-00-00 ✎	71-E079-00-00 ✎	-
		Min.2 - Max.4	Min.1 - Max.4	Min.1 - Max.2		
	DALI2 IP20	71-A190-00-00	71-A192-00-00	71-A192-00-00	71-A191-00-00 ✎	71-A192-00-00 ✎
		Min.2 - Max.4	Min.1 - Max.3	Min.1 - Max.2		
	DALI2 IP68	71-E080-00-00	71-E083-00-00	71-E083-00-00	71-E083-00-00	71-E085-00-00 ✎
		Min.1 - Max.13	Min.1 - Max.4	Min.1 - Max.2		

Connective controllers





P. 969

Contrôleurs connectés







 **Consult the available control systems / Consultez les systèmes de contrôle disponibles:**
 DALI2 / DALI2
 Bluetooth wireless / Sans fil Bluetooth
 DMX / DMX
 Autonomous / Autonome

	Max Mini	Max Medium	Max Big
			

Lens accessories
Accessoires optiques

	Wall washer diffuser (5u.) Diffuseur lèche-mur (5 u.)	71-E462-00-00	71-E463-00-00	71-E464-00-00
	Honeycomb panel (5u.) Grille en nid d'abeille (5 u.)	71-E422-00-00	71-E131-00-00	71-E263-00-00
	Square diffuser (5u.) Diffuseur carré (5 u.)	71-E421-00-00	71-E135-00-00	71-E262-00-00
	Elliptical diffuser (5u.) Diffuseur elliptique (5 u.)	71-E420-00-00	71-E141-00-00	71-E261-00-00
	Opal diffuser (5u.) Diffuseur opalin (5 u.)	71-E419-00-00	71-E133-00-00	71-E260-00-00

Connection accessories
Accessoires de connexion

	IP67 connector (1 input + 1 output) Ø 5.5-7.5 mm, 3 poles Connecteur IP67 (1 entrée + 1 sortie) Ø 5,5 - 7,5 mm, 3 pôles	71-E510-00-00	71-E510-00-00	71-E510-00-00
	IP67 connector (1 input + 2 outputs) Ø 5.5-7.5 mm, 3 poles Connecteur IP67 (1 entrée + 2 sorties) Ø 5,5 - 7,5 mm, 3 pôles	71-E511-00-00 Not for Constant Current	71-E511-00-00 Not for Constant Current	71-E511-00-00 Not for Constant Current
	IP68 connector (1 input + 1 output) Ø 5.5-11.5 mm, 4 poles Connecteur IP68 (1 entrée + 1 sortie) Ø 5,5 - 11,5 mm, 4 pôles	71-E512-00-00	71-E512-00-00	71-E512-00-00
	IP68 connector (1 input + 2 outputs) Ø 5.5-11.5 mm, 3 poles Connecteur IP68 (1 entrée + 2 sorties) Ø 5,5 - 11,5 mm, 3 pôles	71-E513-00-00 Not for Constant Current	71-E513-00-00 Not for Constant Current	71-E513-00-00 Not for Constant Current
	IP68 anti-condensation connector (1 input + 1 output) Ø 5.5-12 mm, 4 poles Connecteur anticondensation IP68 (1 entrée + 1 sortie) Ø 5,5 - 12 mm, 4 pôles	71-E112-00-00 Not for Constant Current	71-E112-00-00 Not for Constant Current	71-E112-00-00 Not for Constant Current
	IP68 anti-condensation connector (1 input + 3 outputs) Ø 5.5-12 mm, 4 poles Connecteur anticondensation IP68 (1 entrée + 3 sorties) Ø 5,5 - 12 mm, 4 pôles	71-E122-00-00	71-E122-00-00	71-E122-00-00
	IP68 connection box (1 input + 5 outputs) Ø 6.5-11 mm, 6 poles Boîtier de raccordement IP67 (1 entrée + 5 sorties) Ø 6,5 - 11 mm, 6 pôles	-	71-9199-05-05	71-9199-05-05

Fixing accessories
Accessoires de fixation

	Recess case Boîtier d'encastrement	71-E467-00-00	71-E467-00-00	71-E467-00-00
-------------------------------------------------------------------------------------	---------------------------------------	---------------	---------------	---------------

Dako

Designed by LedsC4 Architectural

A multi-purpose LED downlight Un encastré de plafond LED polyvalent

Its advanced features, various installation possibilities and, most notably, the three light angles that can be chosen during installation, make Dako the ideal solution when seeking a multi-purpose recessed ceiling light.

Ses hautes prestations, ses différentes possibilités d'installation et, surtout, les trois angles lumineux que ce modèle permet de choisir lors de son installation, font de Dako la solution idéale si l'on recherche un encastré de plafond polyvalent.



Fixed



Adjustable



120°

Includes IP67 remote driver.
Driver distant IP67 fourni.



High visual comfort and UGR < 13 Haut confort visuel et UGR < 13

The reflectors are located in a lower position, therefore preventing glare.
Les réflecteurs sont situés à un niveau inférieur, ce qui évite tout éblouissement.

- ① Metal casing for improved heat dissipation
Corps métallique pour une meilleure dissipation de la chaleur
- ② Recessed LED to prevent glare
LED enfoncée pour éviter l'éblouissement
- ③ Watertight enclosure
Fermeture étanche

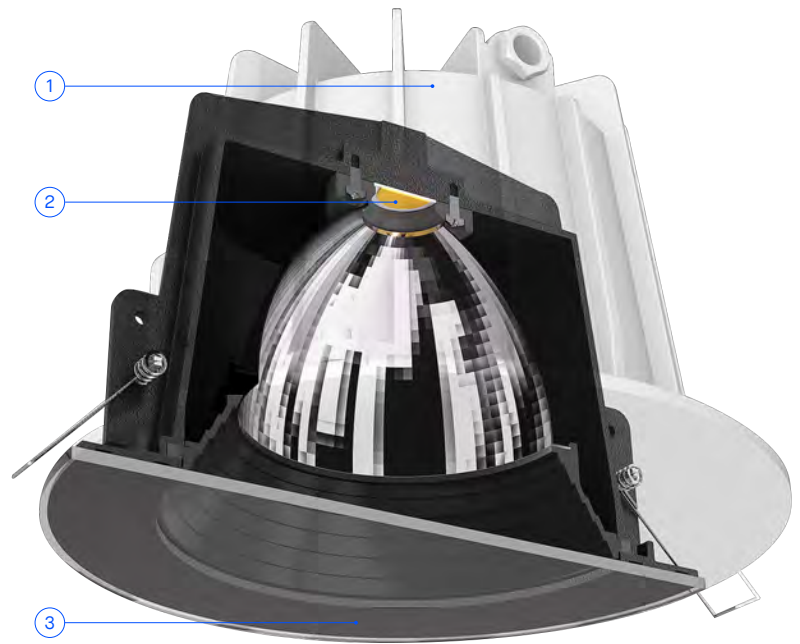



Accessory for concrete ceiling installations Accessoire à installer sur plafond en béton



Dako Fixed



BODY MAT	DIF MAT		50000h	3
AL	GLA		L80 B20	MacAdam

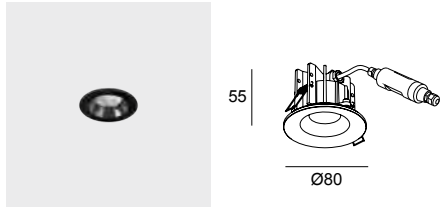

Dako Fixed 80mm

IP	IK	UGR	BREEAM		SEA SIDE SUITABLE		
66	06	<13					

14 05



LED									
K	CRI	W Total	Real Lm	Optics	Code				
3000	80	7.5	502	29°;40°	15-E035 - 14 05 - CL		ON-OFF	100-240V	



 68  0-20 mm

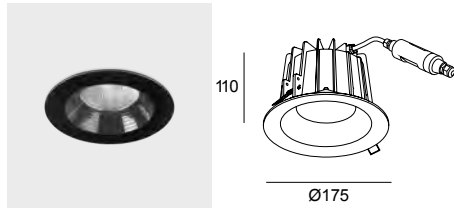

Dako Fixed 175mm

IP	IK	UGR	BREEAM		SEA SIDE SUITABLE		
66	07	<16					

14 05



LED									
K	CRI	W Total	Real Lm	Optics	Code				
3000	80	20	1821	24; 31°	15-E036 - 14 05 - CL		ON-OFF	100-240V	

 155  0-17 mm

Fixed 80mm



Fixed 175mm



Drivers

P. 984



IP67 Driver & Connector
Driver IP67 & connecteur

Included

Included

Lens accessories

Accessoires optiques



Diffuser filter
Filtre diffuseur

Included

Included



Set of 2 reflectors (24° and 31°)
Set de 2 réflecteurs (24° et 31°)

-

Included



Set of 2 reflectors (29° and 40°)
Set de 2 réflecteurs (29° et 40°)

Included

-

Fixing accessories

Accessoires de fixation



Recess case
Boîtier d'encastrement

-

71-E036-00-00

BODY MAT	DIF MAT		50000h	3
AL	GLA		L80 B20	MacAdam

Dako Adjustable 100mm

IP	IK	UGR	BREEAM		SEA SIDE SUITABLE		LED	DRIVER
66	06	<13				±20°		

○ ●
14 05

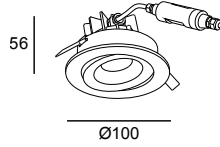

LED									
K	CRI	W Total	Real Lm	Optics	Code				
3000	80	7.5	502	29°;40°	15-E104 - 14 05 - CL	ON-OFF	100-240V		

80 0-20 mm

Dako Adjustable 200mm

IP	IK	UGR	BREEAM		SEA SIDE SUITABLE		LED	DRIVER
66	07	<16				±20°		

○ ●
14 05

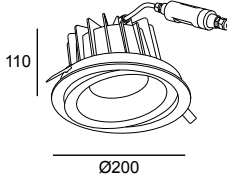
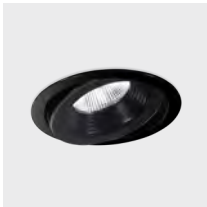

LED									
K	CRI	W Total	Real Lm	Optics	Code				
3000	80	20	1821	24; 31°	15-E105 - 14 05 - CL	ON-OFF	100-240V		

180 0-20 mm

Adjustable 100mm



Adjustable 200mm



Drivers

P. 984



IP67 Driver & Connector
Driver IP67 & connecteur

Included

Included

Lens accessories

Accessoires optiques



Diffuser filter
Filtre diffuseur

Included

Included



Set of 2 reflectors (24° and 31°)
Set de 2 réflecteurs (24° et 31°)

-

Included



Set of 2 reflectors (29° and 40°)
Set de 2 réflecteurs (29° et 40°)

Included

-

Fixing accessories

Accessoires de fixation



Recess case
Boitier d'encastrement

71-E104-00-00

71-E105-00-00

Eko

Designed by LedsC4 Architectural



Spotlight
P. 550



Bollard
P. 744



Wall Fixtures
P. 794



Ceiling
P. 856



An essential GU10 downlight for in-out projects

Un GU10 downlight essentiel pour les projets in-out (intérieur-extérieur)

These fixtures provide a cost-effective solution with maximum reliability and easy maintenance. The Eko collection is ideal for projects aiming to illuminate multiple applications with a single product range.

Offrent une solution abordable, doublée d'un maximum de fiabilité et d'un entretien facile. La collection Eko est parfaite pour les projets qui visent à éclairer différents endroits avec une même collection.



Venting valve reduces LED bulb overheating. La valve d'aération réduit la surchauffe des ampoules LED

Facilitates air circulation, extending the lifespan of LED bulbs.

Facilite la circulation de l'air, prolongeant ainsi la durée de vie des ampoules LED.





Eko Downlight

IP	BODY MAT	IK	DIF MAT			SEA SIDE
65	AL	07	PC	1 m		SUITABLE



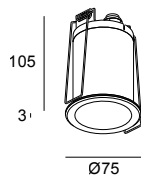



 60 Z5* 14* 34* J6* E3* DL*



 65
  5-50 mm

GU10	
W	Code
Max. 8	60
	Z5
	J6
	15-E065 - E3 - 37
	DL
	14
	34

Connection accessories Accessoires de connexion

	IP68 connector (1 input + 1 output) Ø 5.5–11.5 mm, 4 poles Connecteur IP68 (1 entrée + 1 sortie) Ø 5,5 - 11,5 mm 4 pôles	71-E512-00-00
	IP68 connector (1 input + 2 outputs) Ø 5.5–11.5 mm, 3 poles Connecteur IP68 (1 entrée + 2 sorties) Ø 5,5 - 11,5 mm, 3 pôles	71-E513-00-00
	IP68 anti-condensation connector (1 input + 1 output) Ø 5.5–12 mm, 4 poles Connecteur anticondensation IP68 (1 entrée + 3 sorties) Ø 5,5 - 12 mm, 4 pôles	71-E122-00-00
	Conector anticondensación IP68 (1 entrada + 3 salidas) Ø 5,5 - 12mm, 4 polos Conetor anticondensação IP68 (1 entrada + 3 saídas) Ø 5,5 - 12 mm, 4 polos	71-E112-00-00

Repair accessories Accessoires de réparation

	Bulb extraction kit (suction cup + clamp) Kit d'extraction de l'ampoule (ventouse + pince)	71-E634-00-00
-------------------------------------------------------------------------------------	-----------------------------------------------------------------------------------------------	----------------------

* Please contact our sales team for conditions and delivery times.
 * Consultez notre équipe commerciale pour connaître les conditions et les délais de livraison.

Gea LED



+ Gea



Tiltable LED downlight Downlight LED basculant

Gea LED is a collection of downlights with a tilting light source, designed with an AISI316 stainless steel frame and recommended for coastal settings.

Gea LED est une collection de downlights à source lumineuse basculante, conçue avec une collerette en acier inoxydable AISI316 et recommandée pour les installations en milieu marin.

Gea LED Downlight

50000h	3	BODY MAT	DIF MAT	
L80 B20	MacAdam	AISI316	GLA	

Gea LED Downlight

IP 66	IK 10	UGR <19	BREEAM			SEA SIDE SUITABLE			
----------	----------	------------	--------	--	--	----------------------	--	--	--

CA

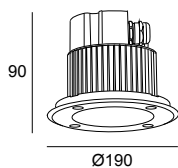

170 12-30 mm

LED							
K	CRI	W Total	Real Lm	Optics	Code		
3000	80	22	1820	40°	15-9948 - CA - CL	ON-OFF 100-240V	
4000	80	22	1915	40°	15-9948 - CA - CM	ON-OFF 100-240V	

Recessed wall lights

Encastrés de mur



Click

612

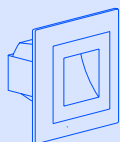

Micenas

615



Bat

618



Tiny

624

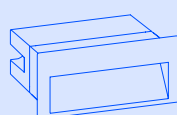

Arc

627

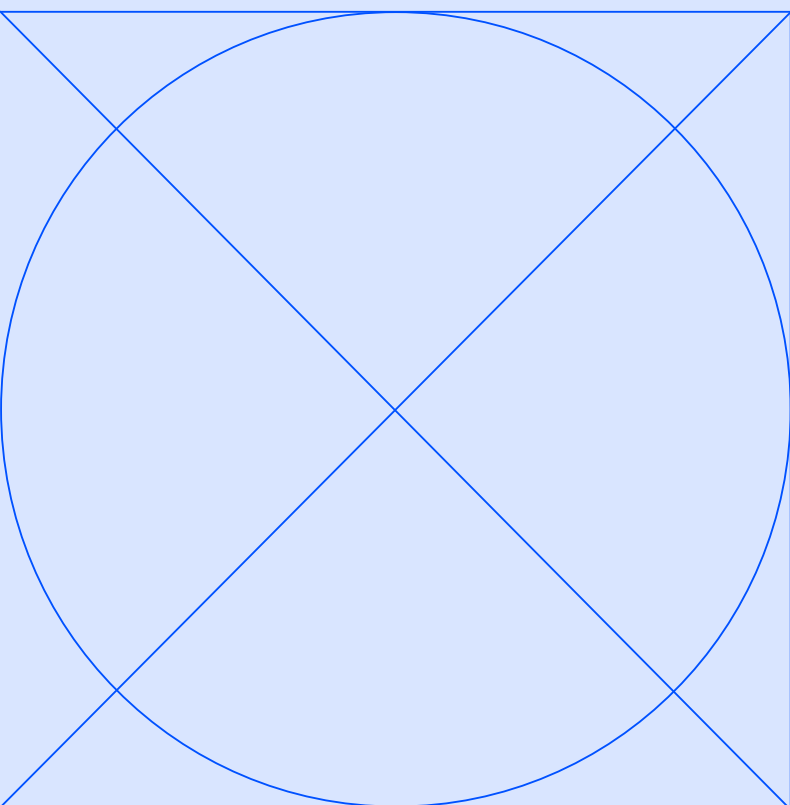
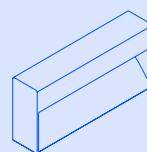

Click

Designed by LedsC4 Architectural



+ Click



Clean, compact design Design épuré et compact

The Click collection is highly practical as it has been designed so that its installation is compatible with universal mechanism boxes. The driver is included inside the luminaire, making installation even more straightforward. La collection Click est très pratique, car elle a été conçue pour être compatible avec les boîtiers d'encastrement universels. Le driver est inclus à l'intérieur du luminaire, ce qui rend l'installation encore plus facile.

Perfect for both indoor and outdoor installations

Parfait tant pour les installations en extérieur qu'en intérieur





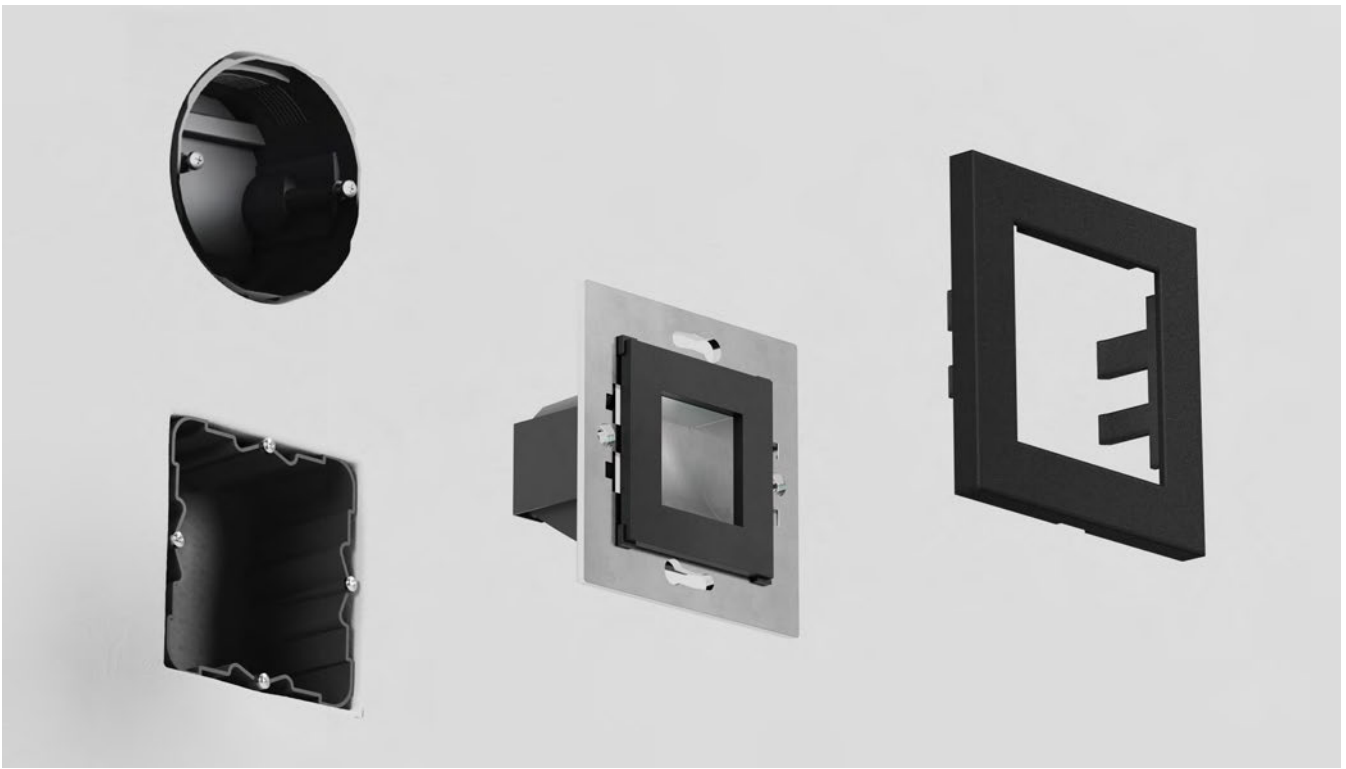

Installation in universal mechanism boxes
 Installation dans des boîtiers d'encastrement universels

Compatible with all universal mechanism boxes: square and round, outdoor and indoor, construction and plasterboard.
 Compatible avec tous les boîtiers d'encastrement universels : carrés et ronds, d'extérieur et d'intérieur, maçonnés ou en placo-plâtre.

Click

BODY MAT	DIF MAT		50000h	IP	IK	SEA SIDE SUITABLE	
PC	GLA		L80 B20	65	07		

05

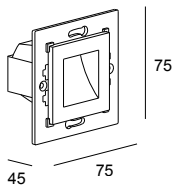

LED						
K	CRI	W	Real Lm	Code		
2700	80	1.1	31	05-E141 - 05 - CK		ON-OFF 220-240V
3000	80	1.1	31	05-E141 - 05 - CL		ON-OFF 220-240V

Decorative accessories
 Accessoires décoratifs



Front
 Pièce frontale

Z5 ● **71-E489-Z5-Z5**

14 ○ **71-E489-14-14**

60 ● **71-E489-60-60**

34 ○ **71-E489-34-34**

J6 ● **71-E489-J6-J6**



Versatile and adaptable
to all spaces

Polyvalent et adaptable
à tous les espaces

Micenas is a complete, all-round, versatile collection, featuring an array of finishes and colour temperatures. It adapts to both compact spaces and large areas, providing precise lighting thanks to the range of models available, which offer specific light effects that adapt to every need.

Micenas est une collection très complète et polyvalente dotée de nombreuses finitions et températures de couleur. Elle s'adapte en éclairant avec précision, aussi bien les espaces compacts que les grandes surfaces, grâce aux différents modèles disponibles avec des effets lumineux spécifiques qui répondent à chaque besoin.

Symmetrical light Lumière symétrique

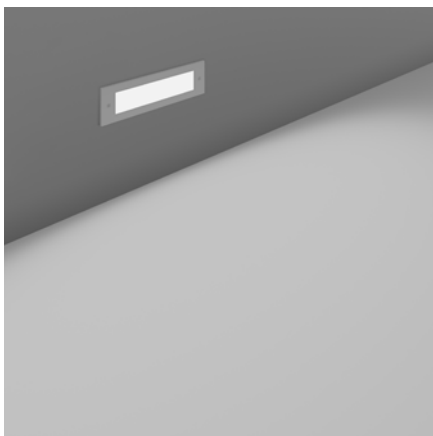

Micenas Symmetrical

Asymmetrical light Lumière asymétrique

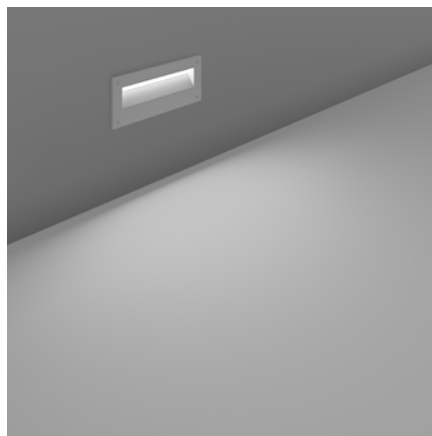

Micenas Asymmetrical

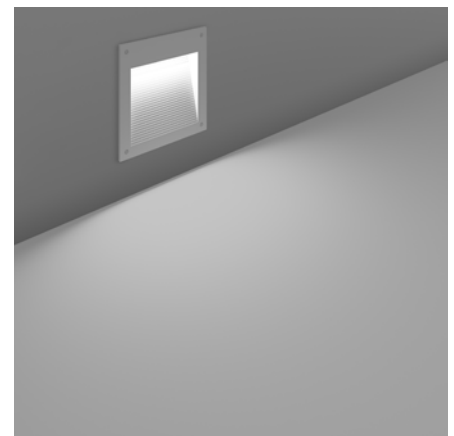

CCT switch included
Interrupteur CCT fourni



CENTRO YUSUF HAMIED



Micenas Symmetrical

BODY MAT	DIF MAT
AL	GLA



50000h
L80 B20

3
MacAdam

IP
66

IK
08

BREEAM



SEA SIDE
SUITABLE



Z5 14* 34* 60* DL* E3* J6*

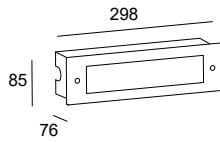

LED										
K	CRI	W Total	Real Lm	Optics	Code					
						Z5				
						14				
						34				
2700-3200-4000	80	10.3	776	113°	05-E165	- 60	- EH	ON-OFF	100-277V	
						DL				
						E3				
						J6				

The indicated flux corresponds to the core temperature.
Le flux indiqué correspond à la température centrale.

Micenas Asymmetrical Rectangular

BODY MAT	DIF MAT
AL	GLA



50000h
L80 B20

3
MacAdam

IP
66

IK
10

SWITCH CCT
2700-3200-4000



BREEAM



Z5 34

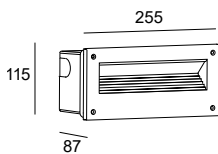

LED										
K	CRI	W Total	Real Lm	Optics	Code					
						Z5				
						34				
2700-3200-4000	80	6.2	500	84°	05-E127	- 25	- EH	ON-OFF	100-240V	
						05-E129				
						05-E135				
								CASAMBI	220-240V	

The indicated flux corresponds to the core temperature.
Le flux indiqué correspond à la température centrale.

Micenas Asymmetrical Square

BODY MAT	DIF MAT
AL	GLA



50000h
L80 B20

3
MacAdam

IP
66

SWITCH CCT
2700-3200-4000



BREEAM



Z5 34

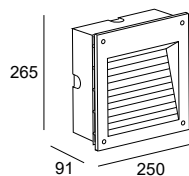
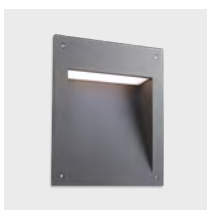

LED										
K	CRI	W Total	Real Lm	Optics	Code					
						Z5				
						34				
2700-3200-4000	80	27.5	1923	97°	05-E128	- 25	- EH	ON-OFF	220-240V	
						05-E134				
						05-E136				
								CASAMBI	110-240V	

The indicated flux corresponds to the core temperature.
Le flux indiqué correspond à la température centrale.

Fixing accessories Accessoires de fixation



Recess case
Boîtier d'encastrement

Included

* Please contact our sales team for conditions and delivery times.
* Consultez notre équipe commerciale pour connaître les conditions et les délais de livraison.

Bat



+ Bat

The elasticity of light in the smallest space L'élasticité de la lumière dans un minimum d'espace

Bat is a signage light that has been meticulously designed down to every last detail, from the sculpting of the light it emits to its structure featuring a textured body in different finishes. Bat est un modèle de signalisation soigné dans les détails, tant dans le façonnage de la lumière qu'elle émet que dans sa structure, avec un corps texturé en différentes finitions.

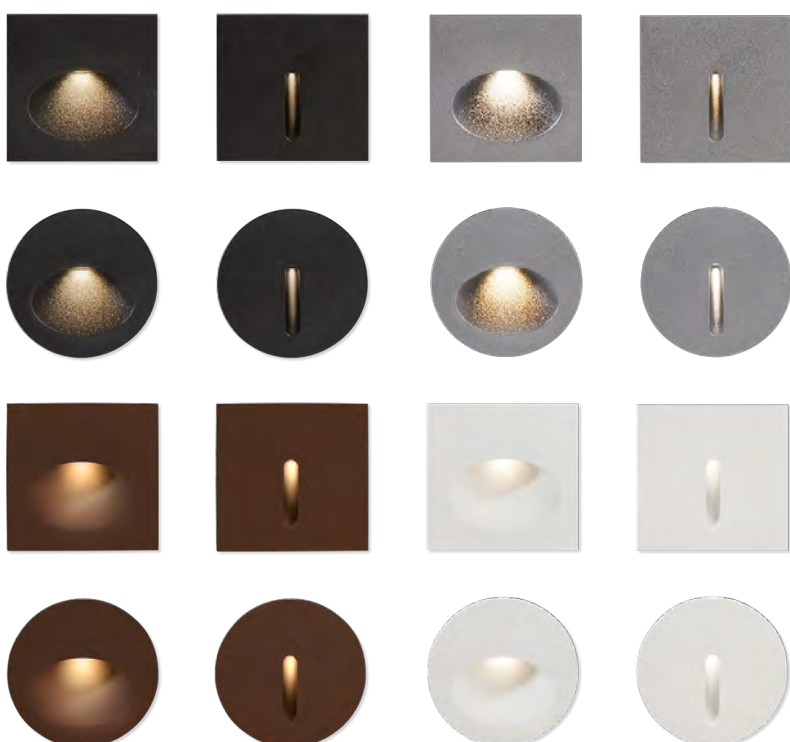
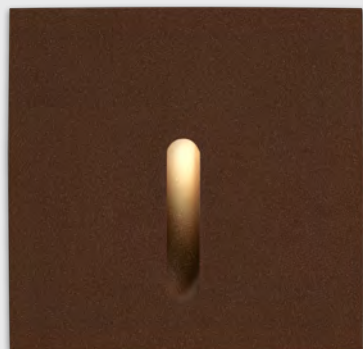



Different effects for adjusting to diverse signage needs.
Différents effets pour répondre aux besoins de signalisation.

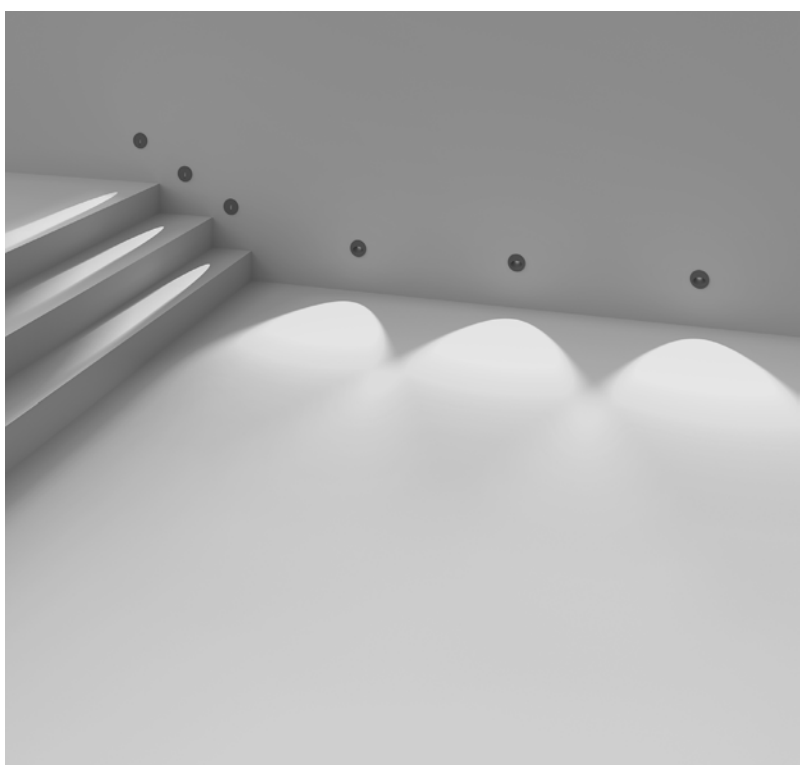

Sunken LED for maximum comfort.
LED renforcée pour un maximum de confort.

Ribs for installation in plasterboard and special anti-open cable gland to ensure watertightness in outdoor settings.
 Ailettes pour installation sur placoplâtre et presse-étoupe spécial anti-ouverture qui garantit son étanchéité dans les espaces extérieurs.



Built-in driver
 Driver intégré



Remote driver
 Driver distant

Bat Square Lineal

BODY MAT	DIF MAT	50000h	3	IP	IK	UGR				
AL	GLA	L80 B20	MacAdam	66	10	<16		1m	SEA SIDE SUITABLE	DIM

Z5 34* J6 14

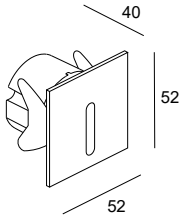

43

LED							max.700mA 3V	
K	CRI	W	Real Lm	Optics	Code	Z5	J6	14
2700	90	2.2	10	23°	05-E017	- 34 - CK	- J6	- 14
3000	90	2.2	10	23°	05-E017	- 34 - CL	- J6	- 14
4000	90	2.2	10	23°	05-E017	- 34 - CM	- J6	- 14

Bat Square Lineal Driver

BODY MAT	DIF MAT	50000h	3	IP	IK	UGR					
AL	GLA	L80 B20	MacAdam	66	10	<16		1m	SEA SIDE SUITABLE	LED	DRIVER

Z5 34* J6 14

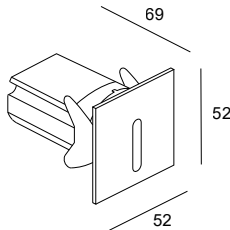
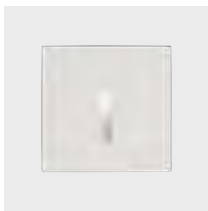

43

LED									
K	CRI	W Total	Real Lm	Optics	Code	Z5	J6	14	
2700	90	3	10	23°	05-E112	- 34 - CK	- J6	- 14	
							ON-OFF 220-240V		
3000	90	3	10	23°	05-E112	- 34 - CL	- J6	- 14	
							ON-OFF 220-240V		
4000	90	3	10	23°	05-E112	- 34 - CM	- J6	- 14	
							ON-OFF 220-240V		

Bat Square Oval

BODY MAT	DIF MAT	50000h	3	IP	IK	UGR				
AL	GLA	L80 B20	MacAdam	66	10	<16		1 m	SEA SIDE SUITABLE	DIM

Z5 34* J6 14

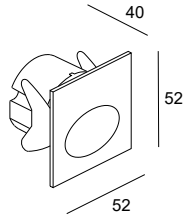

43

LED							max.700mA 3V		
K	CRI	W	Real Lm	Optics	Code	Z5	34	J6	14
2700	90	2.2	77	60°	05-E016	-	CK		
3000	90	2.2	77	60°	05-E016	-	CL		
4000	90	2.2	77	60°	05-E016	-	CM		

Bat Square Oval Driver

BODY MAT	DIF MAT	50000h	3	IP	IK	UGR					
AL	GLA	L80 B20	MacAdam	66	10	<16		1 m	SEA SIDE SUITABLE	LED	DRIVER

Z5 34* J6 14

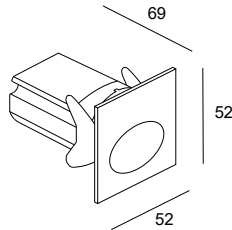
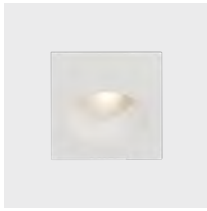

43

LED									
K	CRI	W Total	Real Lm	Optics	Code	Z5	34	J6	14
2700	90	3	77	60°	05-E111	-	CK	ON-OFF	220-240V
3000	90	3	77	60°	05-E111	-	CL	ON-OFF	220-240V
4000	90	3	77	60°	05-E111	-	CM	ON-OFF	220-240V

Bat Round Lineal

BODY MAT	DIF MAT	50000h	3	IP	IK	UGR				
AL	GLA	L80 B20	MacAdam	66	10	<16		1 m	SEA SIDE SUITABLE	DIM

Z5 34* J6 14

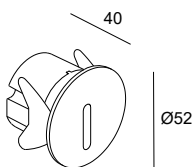
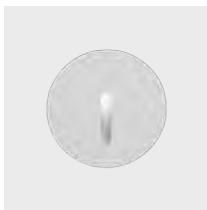

43

LED							max.700mA 3V		
K	CRI	W	Real Lm	Optics	Code	Z5	34	J6	14
2700	90	2.2	10	23°	05-E015	-	CK		
3000	90	2.2	10	23°	05-E015	-	CL		
4000	90	2.2	10	23°	05-E015	-	CM		

Bat Round Lineal Driver

BODY MAT	DIF MAT	50000h	3	IP	IK	UGR					
AL	GLA	L80 B20	MacAdam	66	10	<16		1m	SEA SIDE SUITABLE		

Z5 34* J6 14

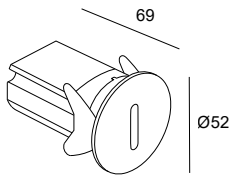

43

LED							
K	CRI	W Total	Real Lm	Optics	Code		
2700	90	3	10	23°	05-E110-34-J6-14-CK	ON-OFF	220-240V
3000	90	3	10	23°	05-E110-34-J6-14-CL	ON-OFF	220-240V
4000	90	3	10	23°	05-E110-34-J6-14-CM	ON-OFF	220-240V

Bat Round Oval

BODY MAT	DIF MAT	50000h	3	IP	IK	UGR				
AL	GLA	L80 B20	MacAdam	66	10	<16		1m	SEA SIDE SUITABLE	DIM

Z5 34* J6 14

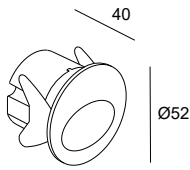
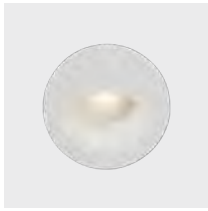

43

LED							max.700mA 3V	
K	CRI	W	Real Lm	Optics	Code			
2700	90	2.2	77	60°	05-E014-34-J6-14-CK			
3000	90	2.2	77	60°	05-E014-34-J6-14-CL			
4000	90	2.2	77	60°	05-E014-34-J6-14-CM			

Bat Round Oval Driver

BODY MAT	DIF MAT	50000h	3	IP	IK	UGR					
AL	GLA	L80 B20	MacAdam	66	10	<16		1m	SEA SIDE SUITABLE		

Z5 34* J6 14

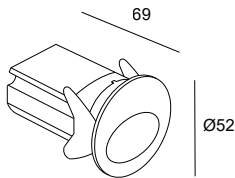
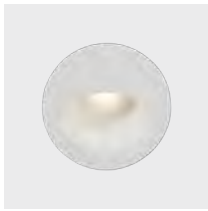

43

LED							
K	CRI	W Total	Real Lm	Optics	Code		
2700	90	3	77	60°	05-E108-34-J6-14-CK	ON-OFF	220-240V
3000	90	3	77	60°	05-E108-34-J6-14-CL	ON-OFF	220-240V
4000	90	3	77	60°	05-E108-34-J6-14-CM	ON-OFF	220-240V

Bat Square & Round







Bat Square & Round Driver





Drivers
Drivers

P. 984

	ON-OFF IP20 * For incorporation into a recessing case * À intégrer dans le boîtier d'encastrement	71-B781-00-00	-
		71-6658-00-00 	-
		Min.4 - Max.9	
	PHASE CUT 240V IP20	71-4898-00-00 	-
		Min.1 - Max.14	
	DALI2 IP20	71-A192-00-00 	-
		Min.4 - Max.13	

Fixing accessories
Accessoires de fixation

	Recessing case for masonry walls Boîtier d'encastrement pour mur en maçonnerie	71-E404-00-00	71-E404-00-00
	Recessing case for masonry/concrete walls to incorporate the 71-B781 driver. Boîtier d'encastrement pour mur en maçonnerie/béton permettant d'intégrer le driver 71-B781.	71-E065-60-00	71-E065-60-00

Connection accessories
Accessoires de connexion

	IP67 connector (1 input + 1 output) Ø 5.5-7.5 mm, 3 poles Connecteur IP67 (1 entrée + 1 sortie) Ø 5,5 - 7,5 mm, 3 pôles	71-E510-00-00	71-E510-00-00
	IP67 connector (1 input + 2 outputs) Ø 5.5-7.5 mm, 3 poles Connecteur IP67 (1 entrée + 2 sorties) Ø 5,5 - 7,5 mm, 3 pôles	-	71-E511-00-00
	IP68 connector (1 input + 1 output) Ø 5.5-11.5 mm, 4 poles Connecteur IP68 (1 entrée + 1 sortie) Ø 5,5 - 11,5 mm, 4 pôles	71-E512-00-00	71-E512-00-00
	IP68 connector (1 input + 2 outputs) Ø 5.5-11.5 mm, 3 poles Connecteur IP68 (1 entrée + 2 sorties) Ø 5,5 - 11,5 mm, 3 pôles	-	71-E513-00-00
	IP68 anti-condensation connector (1 input + 1 output) Ø 5.5-12 mm, 4 poles Connecteur anticondensation IP68 (1 entrée + 1 sortie) Ø 5,5 - 12 mm, 4 pôles	71-E112-00-00	71-E112-00-00
	IP68 anti-condensation connector (1 input + 3 outputs) Ø 5.5-12 mm, 4 poles Connecteur anticondensation IP68 (1 entrée + 3 sorties) Ø 5,5 - 12 mm, 4 pôles	-	71-E122-00-00
	IP67 connection box (1 input + 2 outputs) Ø 6-7.5 mm, 3 poles Boîtier de raccordement IP67 (1 entrée + 2 sorties) Ø 6 - 7,5 mm, 3 pôles	71-9262-05-05	-
	IP68 connection box (1 input + 5 outputs) Ø 6.5-11 mm, 6 poles Boîtier de raccordement IP67 (1 entrée + 5 sorties) Ø 6,5 - 11 mm, 6 pôles	71-9199-05-05	71-9199-05-05

Tiny



Comfort for stairway lighting Confort d'éclairage des cages d'escalier

The compact proportion of its horizontal design and its technical features make Tiny an ideal collection for lighting stairwells, as it adapts to all kinds of steps, as well as different passage areas.

La proportion compacte de son design horizontal et ses prestations techniques font de Tiny une collection idéale pour éclairer les cages d'escalier, car elle s'adapte à toutes sortes de marches, ainsi qu'à différentes zones de passage.

Designed to prevent glare Conçu pour éviter tout éblouissement

The special design of this collection's head allows the LED to be recessed, ensuring excellent visual comfort in any type of installation.

La conception spéciale de sa tête permet d'enfoncer la LED, ce qui garantit un excellent confort visuel dans n'importe quelle installation.

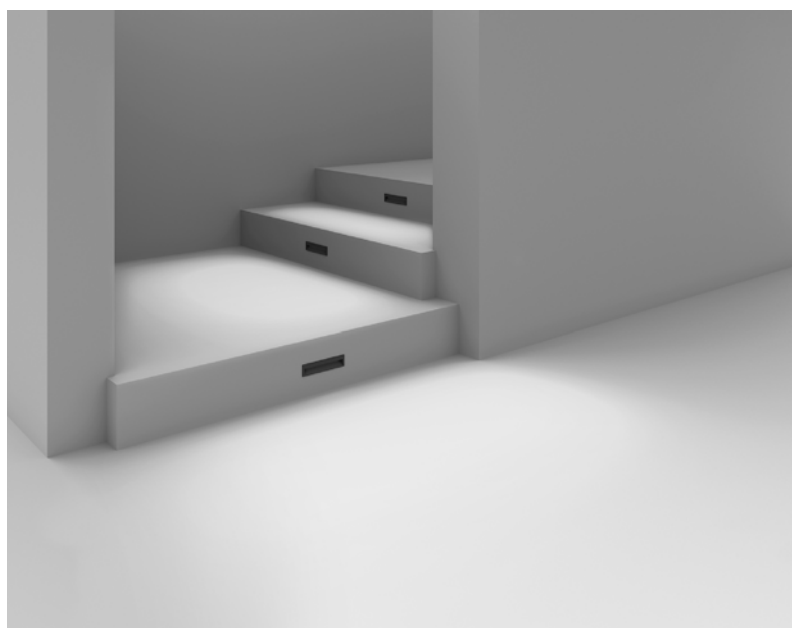

Tiny Short

BODY MAT
AL

DIF MAT
GLA



50000h
L80 B20

3
MacAdam

IP
66

IK
10

2 m

SEA SIDE
SUITABLE



Z5

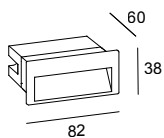
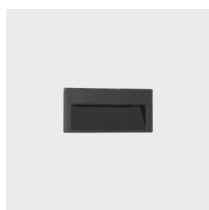

LED						
K	CRI	W Total	Real Lm	Code		
3000	80	2.9	18	05-E146 - Z5 - CL		ON-OFF 220-240V

Tiny Large

BODY MAT
AL

DIF MAT
GLA



50000h
L80 B20

3
MacAdam

IP
66

IK
10

LOW
FLICKER

2 m

SEA SIDE
SUITABLE



Z5

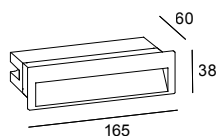
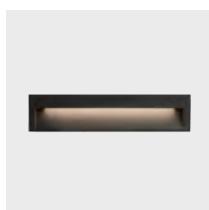

LED						
K	CRI	W Total	Real Lm	Code		
3000	80	7.8	74	05-E147 - Z5 - CL		ON-OFF 220-240V

Fixing accessories

Accessoires de fixation



Recess case
Boîtier d'encastrement

Included

Connection accessories

Accessoires de connexion



IP68 anti-condensation connector (1 input + 1 output) Ø 5.5-12 mm, 4 poles
Connecteur anticondensation IP68 (1 entrée + 1 sortie) Ø 5,5 - 12 mm, 4 pôles

71-E112-00-00



IP68 anti-condensation connector (1 input + 3 outputs) Ø 5.5-12 mm, 4 poles
Connecteur anticondensation IP68 (1 entrée + 3 sorties) Ø 5,5 - 12 mm, 4 pôles

71-E122-00-00



IP67 connection box (1 input + 2 outputs) Ø 6-7.5 mm, 3 poles
Boîtier de raccordement IP67 (1 entrée + 2 sorties) Ø 6 - 7,5 mm, 3 pôles

71-9262-05-05



IP68 connection box (1 input + 5 outputs) Ø 6.5-11 mm, 6 poles
Boîtier de raccordement IP67 (1 entrée + 5 sorties) Ø 6,5 - 11 mm, 6 pôles

71-9199-05-05





Ideal for concrete façades Idéale pour les façades en béton

Arc is made entirely of cement, allowing for easy integration into architecture.
Étant entièrement réalisée en ciment, l'applique Arc se fond facilement dans l'architecture.

Arc

BODY MAT AL.CON	DIF MAT GLA		50000h L80 B20	3 MacAdam	IP 66	IK 10		SEA SIDE SUITABLE		
--------------------	----------------	--	-------------------	--------------	----------	----------	--	----------------------	--	--

DC

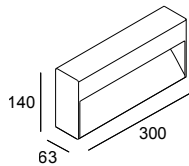

LED					
K	CRI	W Total	Real Lm	Code	
3000	80	9	404	05-E090 - DC - CL	ON-OFF 220V

300x140

Fixing accessories Accessoires de fixation



Recess case
Boîtier d'encastrement

Z5 ●

71-E090-Z5-00

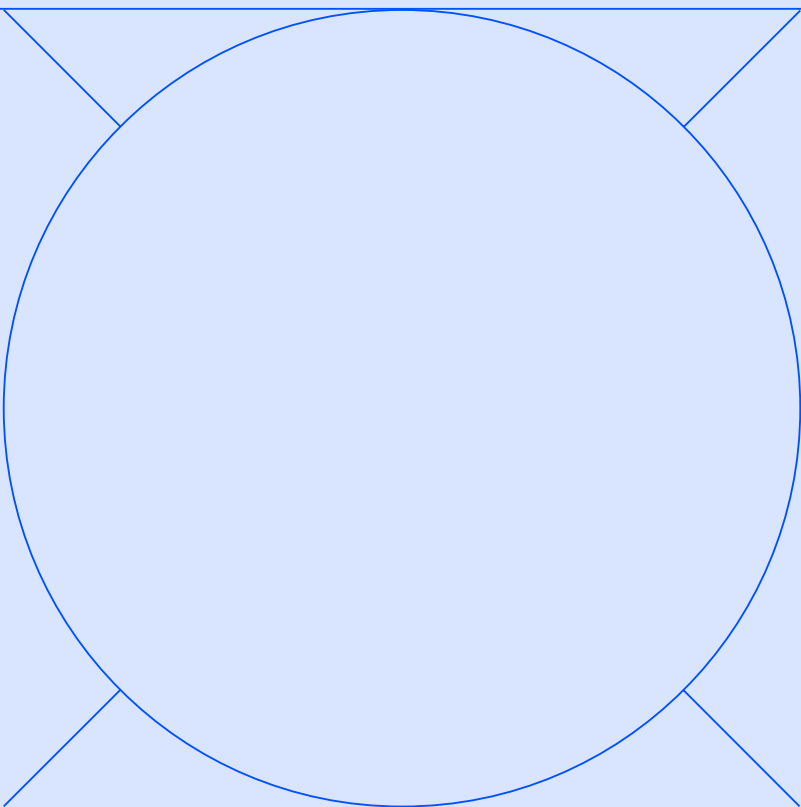

Recessed floor lights

Encastrés de sol

Max

630



Aro

636



Gea

642

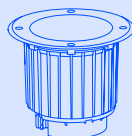

Kay

666

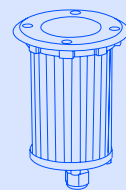

Ios

668

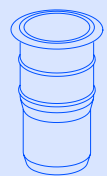

Rim

674

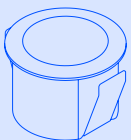

Pixel

678



Xena

682

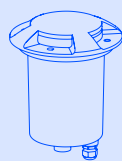

Max

Designed by LedsC4 Architectural



Bollard
P. 738



Wall Fixture
P. 788



Ceiling
P. 852

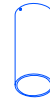

Spotlight
P. 540



Downlight
P. 598



Excellent light control Excellent contrôle lumineux

The aim of the Max recessed floor lights is to offer maximum control. To achieve this, it uses a wide range of options: lenses, outputs, adjustment features, colour temperatures, finishes and lens accessories. By combining these options, total control of the light is achieved to adapt it to all situations and needs. Le but des encastrés de sol Max est d'offrir un maximum de contrôle. Pour cela, ils s'appuient sur un vaste éventail d'options : lentilles, puissances, variations, températures de couleur, finitions et accessoires optiques. En combinant ces options, on obtient un contrôle total de la lumière pour répondre à toutes les situations et à tous les besoins.

New metallic finishes Nouvelles finitions métalliques

Stainless steel (CA)
Acier inoxydable (CA)

Gold brass (17)
Laiton doré (17)

Brushed chrome (18)
Chrome poli (18)



Small
Ø 35 mm

Medium
Ø 50 mm

Big
Ø 75 mm





Max Small Uplight

BODY MAT AL	DIF MAT GLA		50000h L80 B20	2 MacAdam	IP 66-68	IK 04	 1000 Kg	 5m			
----------------	----------------	--	-------------------	--------------	-------------	----------	-------------	--------	--	--	--

Code example / Exemple d'élaboration d'une référence: **BA11-P2P8S1BBZ5**

Model	W	K	CRI	Optics	Real Lm	Source	Finishes	
BA11 - 47mm Square ⌀ 33 CA I7 I8	Constant Current 700mA							
	P2P8	2.5	2200	80	S1 10°	152 - 163	BB 3V/max.700mA	CA I7 I8 Z5
	P2V8	2.2	2700	80	S2 15°	172 - 185		
	P2W8	2.2	3000	80	M3 32°	178 - 191		
P2X8	2.2	4000	80	F2 53°	147 - 158			
BA12 - Ø47mm Round ⌀ 33 CA I7 I8	Constant Voltage 24V							
	P3V8	2.5	2700	80	S3 19°	94	BB 24VDC PWM	
	P3W8	2.5	3000	80	M3 32°	97		
BA13 - Ø32mm Round Trimless Z5	P3X8	2.5	4000	80	F2 51°	87		

Max Medium Uplight

BODY MAT AL	DIF MAT GLA		50000h L80 B20	2 MacAdam	IP 66-68	IK 10	 5 m			
----------------	----------------	--	-------------------	--------------	-------------	----------	---------	--	--	--

Code example / Exemple d'élaboration d'une référence: **A111-P4V9S1BBZ5**

Model	W	K	CRI	Optics	Real Lm	Source	Finishes	
A111 - 75mm Square ⌀ 60 CA I7 I8	Constant Current 350mA							
	P4V9	4	2700	90	S1 9°	286	BB 12V/max.350mA	CA I7 I8 Z5
	P4W9	4	3000	90				
P4X9	4	4000	90					
A112 - Ø75mm Round ⌀ 60 CA I7 I8	P7P8	6.5	2200	80	S2 17°	519	BB 18V/max.350mA	
	P7V9	6.5	2700	90	M2 27°	459		
	P7W9	6.5	3000	90	F1 50°	423		
	P7X9	6.5	4000	90				
A113 - Ø58mm Round Trimless Z5	Constant Voltage 24V							
	P6V9	6	2700	90	S1 9°	204	BB 24VDC PWM	
	P6W9	6	3000	90				
	P6X9	6	4000	90				
	P8V9	7.9	2700	90	S2 17°	519	BB 24VDC PWM	
	P8W9	7.9	3000	90	M2 27°	459		
P8X9	7.9	4000	90	F1 50°	423			

Max Big Uplight

BODY MAT AL	DIF MAT GLA		50000h L80 B20	2 MacAdam	IP 66-67	IK 10	 5 m	SEA SIDE SUITABLE		LED	 DIM
----------------	----------------	--	-------------------	--------------	-------------	----------	---------	----------------------	--	-----	---------

Code exemple / Exemple d'élaboration d'une référence: **AT11-13V9S1BBZ5**

Model		W	K	CRI	Optics	Real Lm	Source	Finishes	
AT11 - 110mm Square 85	 CA I7 I8	Constant Current 350mA							
		13V9	13.7	2700	90	S1 10°	931 - 1054	BB 36V/max.350mA	CA I7 I8
		13W9	13.7	3000	90				
		13X9	13.7	4000	90				
		18P8	17.3	2200	80	S3 21°	1844 - 2126	BB 36V/max.500mA	
		AT12 - Ø110mm Round 85	 CA I7 I8	Constant Current 350mA					
18V9	17.3			2700	90	M3 31°	1902 - 2191		
18W9	17.3			3000	90	F1 40°	1565 - 1812		
18X9	17.3			4000	90				
Constant Voltage 24V									
AT13 - Ø110mm Round Trimless 155	 CA	14V9	13.8	2700	90	S3 16°	1086	BB 24VDC PWM	
		14W9	13.8	3000	90	M2 28°	1076		
		14X9	13.8	4000	90	F2 51°	1120		

2 remote power supply options
 2 possibilités d'alimentation à distance

350mA
 500mA
 700mA





24V

Constant Voltage 24V

Power supplies

P. 985

Sources d'alimentation

	ON-OFF IP20	Max.20W	71-B650-00-00		DALI2 IP20	Max.60W	71-B652-00-00
		Max.30W	71-B640-00-00			Max.150W	71-B653-00-00
		Max.100W	71-B641-00-00			Max.250W	71-B654-00-00
		Max.150W	71-B642-00-00			Max.60W	71-B655-00-00
	ON-OFF IP67	Max.30W	71-B644-00-00		DALI2 IP67	Max.160W	71-B656-00-00
		Max.60W	71-B645-00-00			Max.240W	71-B675-00-00
		Max.100W	71-B646-00-00				
		Max.160W	71-B647-00-00				
		Max.240W	71-B648-00-00				

Constant Current

Max Mini

Max Medium
P4Max Medium
P7















Max Big



Drivers

P. 984

Drivers

	ON-OFF IP20	71-B682-00-00 	71-A652-00-00 	71-6652-00-00  Min.2 - Max.2	71-7551-00-00 
		71-3542-00-00  Min.2 - Max.22	71-3542-00-00  Min.1 - Max.6	71-3542-00-00  Min.1 - Max.3	71-3542-00-00  Min.1 - Max.2
	ON-OFF IP68	71-E014-00-00 Min.2 - Max.4	71-E079-00-00  Min.1 - Max.4	71-E079-00-00  Min.1 - Max.2	-
		71-A190-00-00 Min.2 - Max.4	71-A192-00-00 Min.1 - Max.3	71-A192-00-00 Min.1 - Max.2	71-A192-00-00 
	DALI2 IP68	71-E080-00-00 Min.1 - Max.13	71-E083-00-00 Min.1 - Max.4	71-E083-00-00 Min.1 - Max.2	71-E085-00-00 

Connective controllers

P. 969

Contrôleurs connectés





Consult the available control systems / Consultez les systèmes de contrôle disponibles:

DALI2 / DALI2





Bluetooth wireless / Sans fil Bluetooth

DMX / DMX







Autonomous / Autonome

	Max Mini	Max Medium	Max Big
			

Lens accessories
Accessoires optiques

	Wall washer diffuser (5u.) Diffuseur lèche-mur (5 u.)	71-E462-00-00	71-E463-00-00	71-E464-00-00
	Honeycomb panel (5u.) Grille en nid d'abeille (5 u.)	71-E422-00-00	71-E131-00-00	71-E263-00-00
	Square diffuser (5u.) Diffuseur carré (5 u.)	71-E421-00-00	71-E135-00-00	71-E262-00-00
	Elliptical diffuser (5u.) Diffuseur elliptique (5 u.)	71-E420-00-00	71-E141-00-00	71-E261-00-00
	Opal diffuser (5u.) Diffuseur opalin (5 u.)	71-E419-00-00	71-E133-00-00	71-E260-00-00

Connection accessories
Accessoires de connexion

	IP67 connector (1 input + 1 output) Ø 5.5–7.5 mm, 3 poles Connecteur IP67 (1 entrée + 1 sortie) Ø 5,5 - 7,5 mm, 3 pôles	71-E510-00-00	71-E510-00-00	71-E510-00-00
	IP67 connector (1 input + 2 outputs) Ø 5.5–7.5 mm, 3 poles Connecteur IP67 (1 entrée + 2 sorties) Ø 5,5 - 7,5 mm, 3 pôles	71-E511-00-00 Not for Constant Current	71-E511-00-00 Not for Constant Current	71-E511-00-00 Not for Constant Current
	IP68 connector (1 input + 1 output) Ø 5.5–11.5 mm, 4 poles Connecteur IP68 (1 entrée + 1 sortie) Ø 5,5 - 11,5 mm, 4 pôles	71-E512-00-00	71-E512-00-00	71-E512-00-00
	IP68 connector (1 input + 2 outputs) Ø 5.5–11.5 mm, 3 poles Connecteur IP68 (1 entrée + 2 sorties) Ø 5,5 - 11,5 mm, 3 pôles	71-E513-00-00 Not for Constant Current	71-E513-00-00 Not for Constant Current	71-E513-00-00 Not for Constant Current
	IP68 anti-condensation connector (1 input + 1 output) Ø 5.5–12 mm, 4 poles Connecteur anticondensation IP68 (1 entrée + 1 sortie) Ø 5,5 - 12 mm, 4 pôles	71-E112-00-00 Not for Constant Current	71-E112-00-00 Not for Constant Current	71-E112-00-00 Not for Constant Current
	IP68 anti-condensation connector (1 input + 3 output) Ø 5.5–12 mm, 4 poles Connecteur anticondensation IP68 (1 entrée + 3 sorties) Ø 5,5 - 12 mm, 4 pôles	71-E122-00-00	71-E122-00-00	71-E122-00-00
	IP68 connection box (1 input + 5 outputs) Ø 6.5–11 mm, 6 poles Boîtier de raccordement IP67 (1 entrée + 5 sorties) Ø 6,5 - 11 mm, 6 pôles	-	71-9199-05-05	71-9199-05-05

Fixing accessories
Accessoires de fixation

	Recess case Boîtier d'encastrement	71-E418-00-00 BA13- Included	71-E139-00-00 AI13- Included	71-E264-00-00 AT13- Included
-------------------------------------------------------------------------------------	---------------------------------------	----------------------------------------	----------------------------------------	----------------------------------------



+ Aro



IP68 solution that doesn't require drainage Solution IP68 n'exigeant pas de drainage

Recessed luminaires designed to illuminate spaces with high humidity levels reliably and precisely. During their manufacturing, top priority was given to ensuring maximum robustness and product durability, with the added advantage of not needing drainage. This is the sole collection of recessed luminaires with this remarkable feature. Furthermore, they offer high-performance lighting control and a wide range of options, including lenses, colour temperatures and dimming.

Luminaires encastrés conçus pour éclairer avec fiabilité et précision optique les espaces concentrant une grande quantité d'humidité. Leur fabrication a tenu compte de la nécessité de garantir un maximum de robustesse et de durabilité du produit, avec en prime le fait qu'ils ne nécessitent pas de drainage. Il s'agit de la seule collection de luminaires encastrés qui présente cet atout important. En outre, elle offre des prestations élevées en matière de contrôle de la lumière et une vaste gamme d'options, notamment en matière d'optiques, de températures de couleur et de gradation.

Symetrical



Symetrical + Honeycomb



Opal



Wallwasher

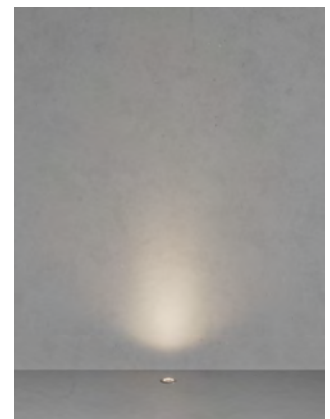

Lenses to modulate the light
Optiques permettant de moduler la lumière



They can be directly installed in grass or soil without the need for concrete
Possibilité d'installation directe sur gazon ou en terre, sans nécessité de béton

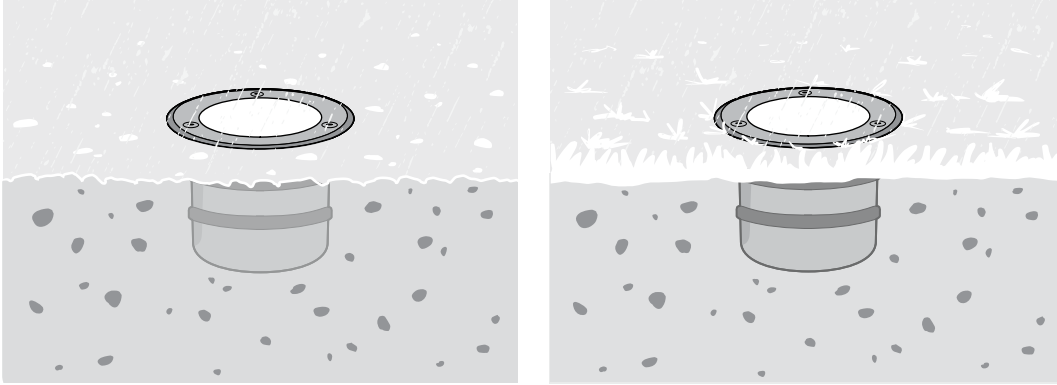

Easily replaceable LED
LED facilement interchangeable



STOP-WATER system Système STOP-WATER

The STOP-WATER system prevents the ingress of water and air, ensuring an extended lifespan.

Le système STOP-WATER empêche l'entrée d'eau et d'air, assurant une plus longue durée de vie.

- ① **Body, frame and screws made entirely from AISI316 stainless steel.**
Corps, cadre et visserie fabriqués à 100 % en acier inoxydable AISI316.
- ② **Anti-vandalism screws to deter tampering with the luminaire.**
Visserie anti-vandalisme permettant d'éviter la manipulation du luminaire.
- ③ **Special anti-opening cable gland for waterproofing assurance.**
Presse-étoupes anti-ouverture assurant l'étanchéité.
- ④ **Neoprene cable for improved luminaire reliability and user-friendliness.**
Câble en néoprène permettant de faciliter et de maximiser la fiabilité du luminaire.
- ⑤ **Customisable lens module.**
Module optique personnalisable.
- ⑥ **Includes an internal STOP-WATER system.**
Système STOP-WATER interne fourni.

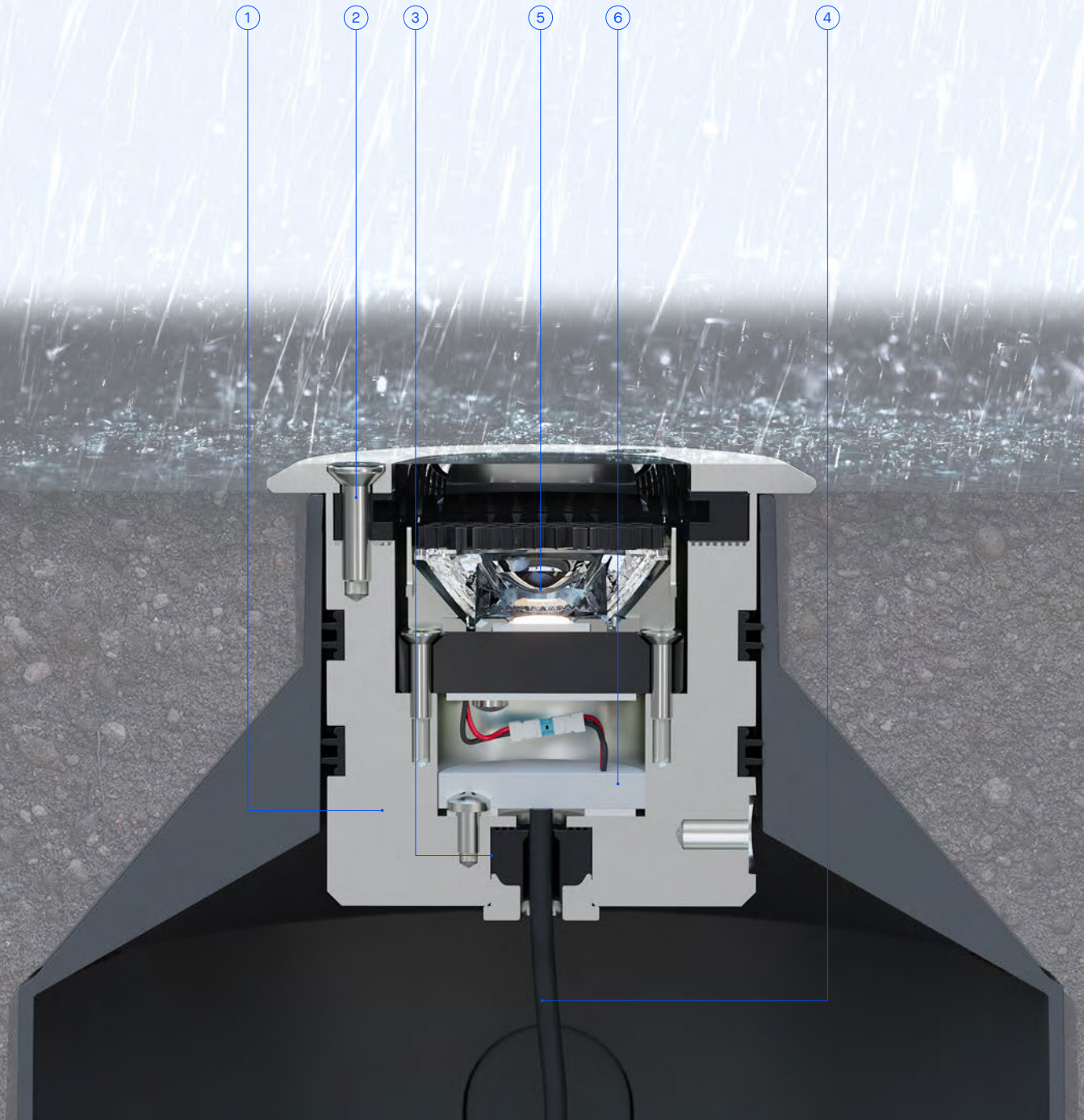

Aro Small Ø45

BODY MAT AL	DIF MAT GLA		50000h L80 B20	2 MacAdam	IP 66-68 5m	 180°	IK 10	 2 m	SEA SIDE SUITABLE			
----------------	----------------	--	-------------------	--------------	-------------------	----------	----------	---------	----------------------	--	--	--

Code example / Exemple d'élaboration d'une référence: **BJ14-P3V9S3BBCA**

Model		W	K	CRI	Optics	Real Lm	Source	Finishes
BJ14 - Ø45mm 	P3V9	2.7	2700	90	S3 19°	101-109	BB 24VDC PWM	CA
	P3W9	2.7	3000	90	M3 34°	118-127		
	P3X9	2.7	4000	90	F2 50°	87-94		
					T3 19° Honeycomb incl.	72-78		
					K3 28° Honeycomb incl.	76-83		
					N2 40° Honeycomb incl.	54-58		
					PL Opal	71-76		

Aro Medium Ø75

BODY MAT AL	DIF MAT GLA		50000h L80 B20	2 MacAdam	IP 66-68 5m	 180°	IK 10	 2 m	SEA SIDE SUITABLE			
----------------	----------------	--	-------------------	--------------	-------------------	----------	----------	---------	----------------------	--	--	--

Code example / Exemple d'élaboration d'une référence: **BJ15-PSV9S3BBCA**

Model		W	K	CRI	Optics	Real Lm	Source	Finishes
BJ15 - Ø75mm 	P6V9	6.1	2700	90	S3 15°	386-444	BB 24VDC PWM	CA
	P6W9	6.1	3000	90	M3 36°	393-452		
	P6X9	6.1	4000	90	F2 62°	400-460		
					T3 18° Honeycomb incl.	239-275		
					K3 31° Honeycomb incl.	253-292		
					N2 62° Honeycomb incl.	386-444		
					PL Opal	286-329		
					R2 Wallwasher			

Aro Big Ø100

BODY MAT AL	DIF MAT GLA		50000h L80 B20	2 MacAdam	IP 66-68 5m	 180°	IK 10	 2 m	SEA SIDE SUITABLE			
----------------	----------------	--	-------------------	--------------	-------------------	----------	----------	---------	----------------------	--	--	--

Code example / Exemple d'élaboration d'une référence: **BJ16-12V9S2BBCA**



Model		W	K	CRI	Optics	Real Lm	Source	Finishes
BJ16 - Ø100mm 	12V9	13.2	2700	90	S2 14°	1034-1190	BB 24VDC PWM	CA
	12W9	13.2	3000	90	M3 38°	1050-1209		
	12X9	13.2	4000	90	F2 62°	1114-1281		
					T2 14° Honeycomb incl.	717-825		
					K3 33° Honeycomb incl.	690-794		
					N2 47° Honeycomb incl.	612-704		
					PL Opal	858-987		
					R2 Wallwasher			



Power supplies

P. 985

Sources d'alimentation

	ON-OFF IP20	Max. 75W	71-A258-00-00		DALI2 IP20	Max. 60W	71-B663-00-00
		Max. 120W	71-A259-00-00			Max. 100W	71-B664-00-00
	ON-OFF IP20	Max. 100W	71-B641-00-00				
		Max. 160W	71-B642-00-00				
		Max. 400W	71-B643-00-00				
		Max. 600W	71-B643-00-00				

Aro Small



Aro Medium



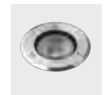

Aro Large



Fixing accessories

Accessoires de fixation

	Recess case Boîtier d'encastrement	71-E418-00-00	71-E139-00-00	71-E264-00-00
	Submersible recess case Boîtier d'encastrement submersible	71-E627-00-00	71-E628-00-00	71-E629-00-00

Connection accessories

Accessoires de connexion

	IP68 connector (1 input + 1 output) Ø 5.5–11.5 mm, 4 poles Connecteur IP68 (1 entrée + 1 sortie) Ø 5,5 - 11,5 mm, 4 pôles	71-E512-00-00	71-E512-00-00	71-E512-00-00
	IP68 connector (1 input + 2 outputs) Ø 5.5–11.5 mm, 3 poles Connecteur IP68 (1 entrée + 2 sorties) Ø 5,5 - 11,5 mm, 3 pôles	71-E513-00-00	71-E513-00-00	71-E513-00-00
	IP68 anti-condensation connector (1 input + 1 output) Ø 5.5–12 mm, 4 poles Connecteur anticondensation IP68 (1 entrée + 1 sortie) Ø 5,5 - 12 mm, 4 pôles	71-E112-00-00	71-E112-00-00	71-E112-00-00
	IP68 anti-condensation connector (1 input + 3 outputs) Ø 5.5–12 mm, 4 poles Connecteur anticondensation IP68 (1 entrée + 3 sorties) Ø 5,5 - 12 mm, 4 pôles	71-E122-00-00	71-E122-00-00	71-E122-00-00

Gea

Designed by LedsC4 Architectural



+ Gea

Ever-evolving, extensive collection
Collection très vaste en constante évolution



Gea Pro



Gea Cob



Gea Wall Washer



Gea Compact



Gea Technopolymer



Gea Signaling





Art & Design International Center

Gea Pro

646

Advanced solution, perfect for architecture and monuments.

Solution avancée, parfaite pour l'architecture et les monuments.

Gea Cob

653

With multiple accessories, ideal for vegetation.

Multi-accessoires, idéale pour la végétation.

Efficiency

Comfort

Ø 85 mm



Ø 125 mm



Ø 185 mm



Ø 220 mm



Ø 300 mm



4.2 W - 35.4 W

4.2 W - 35.4 W

10.5 W - 35 W



S - M - F



S - M - F



S - M - F



S: Spot (9-20°) **M:** Medium (21-40°) **F:** Flood (41-100°) **FA** Flood Asymmetrical

Gea Wall Washer

656

Solution for wash-lighting façades.
Solution lèche-mur pour façades.

Gea Compact

658

Solution for shallow floors.
Solution pour les sols peu profonds.

Gea Signaling

660

Signage lighting solution.
Solution d'éclairage de signalisation.

Gea Technopolymer

662

Solution that can be installed directly in the ground, without using concrete.
Solution à installer directement en terre, sans utiliser de béton.

Ø 45 mm

Ø 120 mm



Ø 130 mm

Ø 60 mm

Ø 130 mm



Ø 180 mm



18.5 W - 27.5 W

8.6 W - 22 W

0.5 W - 2.2 W

7.7 W - Max. 50 W



FA

S - M

S - M - F



CA

CA

54

CA

Gea Pro

Efficiency



Comfort



Advanced solution, perfect for architecture
and monuments
Solution avancée, parfaite pour l'architecture
et les monuments

Gea Comfort illuminates
specific angles
Gea Comfort éclaire des
angles spécifiques

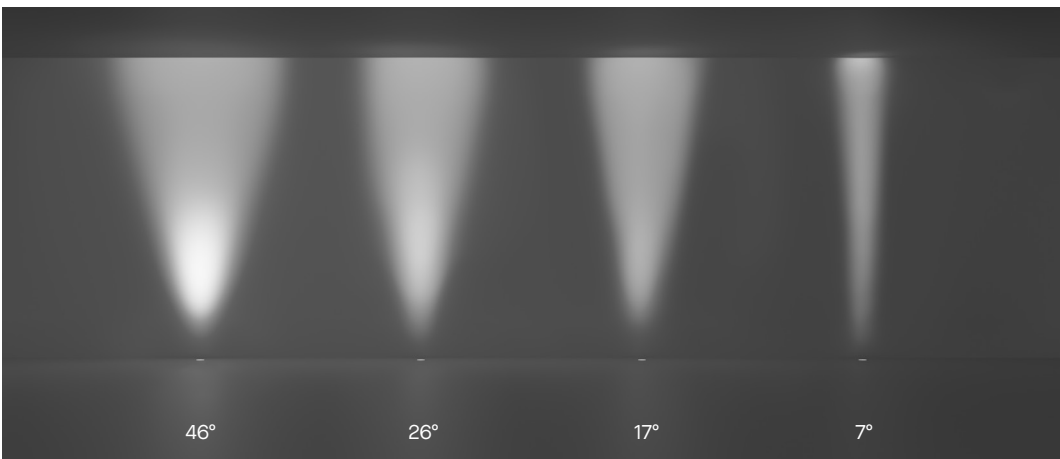

Gea Comfort
185 mm





Gea

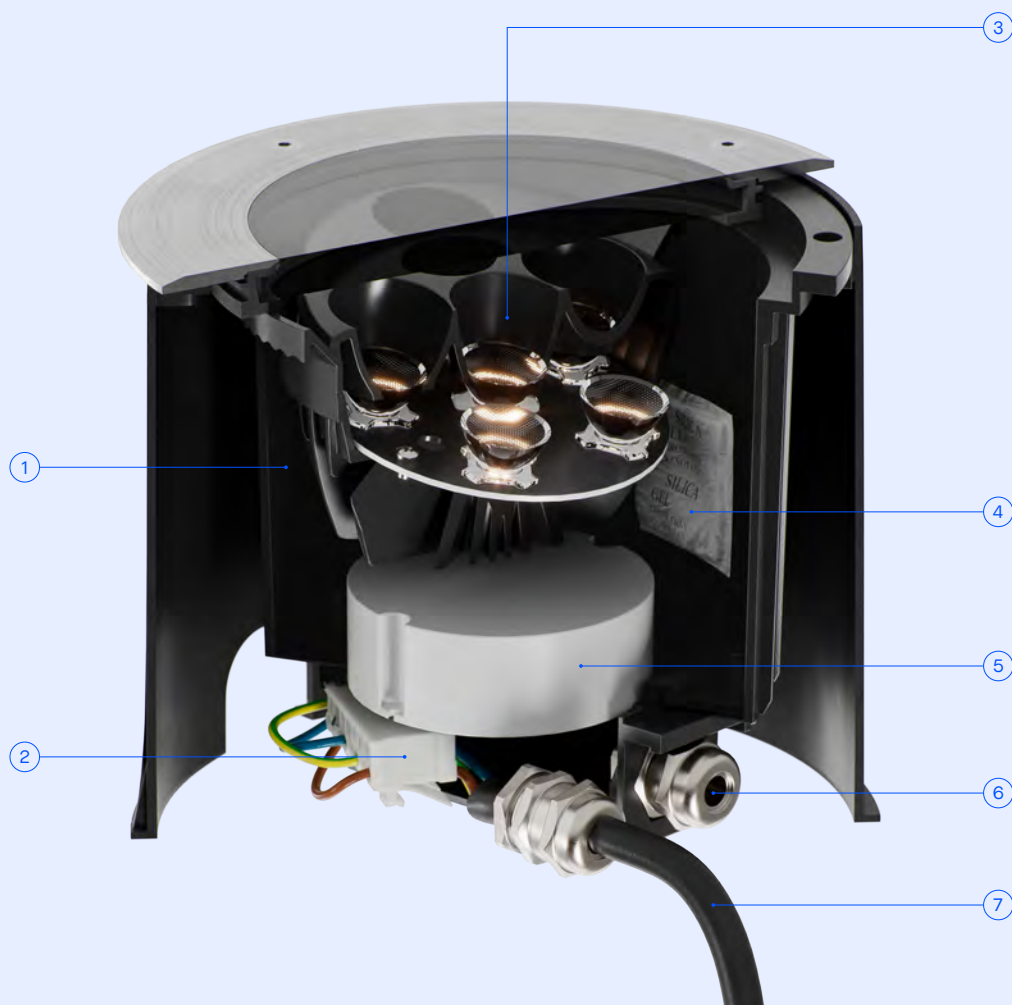

- ① **Anti-glare visor**
Visière anti-éblouissement
- ② **6 mm glass diffuser**
Diffuseur en verre de 6 mm
- ③ **Anti-glare**
Anti-éblouissement
- ④ **Moisture absorber**
Absorbe l'humidité

- ⑤ **Drivers Included**
Driver fourni
- ⑥ **Double cable gland**
Double presse-étoupe
- ⑦ **Cable included**
Cordon inclus

Gea Power LED Pro

IK 10		50000h L80 B20	3 MacAdam	BODY MAT AISI316, POLI	DIF MAT GLA
----------	--	-------------------	--------------	---------------------------	----------------

OUTDOOR

Gea Pro Ø85mm

IP 65-67		2.5 m	SEA SIDE SUITABLE		360°	±15°		LED	DRIVER
-------------	--	-------	----------------------	--	------	------	--	-----	--------

Code example / Exemple d'élaboration d'une référence: **AZ11-P4V8S3OUC**A

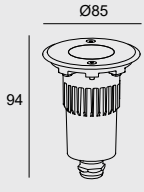
Model		W	K	CRI	Optics	Real Lm	Source	Finishes
AZ11 - Ø85mm Efficiency 	P4V8	2	2700	80	S3 10°	194	OU ON-OFF 100-240V	CA
	P4W8	2	3000	80	M2 26°	177		
	P4X8	2	4000	80	F1 73°	182		

Gea Pro Efficiency Ø125mm

IP 66-67		1 m	SEA SIDE SUITABLE		±15°	360		LED	DRIVER
-------------	--	-----	----------------------	--	------	-----	--	-----	--------

Code example / Exemple d'élaboration d'une référence: **AZ13-P2V8S1OUC**A

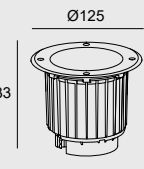
Model		W	K	CRI	Optics	Real Lm	Source	Finishes
AZ13 - Ø125mm Efficiency 	P2V8	2.1	2700	80	S1 10°	203	OU ON-OFF 100-240V	CA
	P2W8	2.1	3000	80				
	P2X8	2.1	4000	80				
	P6V8	6.3	2700	80	S3 11°	501 - 583	OU ON-OFF 100-240V	
	P6W8	6.3	3000	80	M2 25°	578 - 672	DU DALI-2 120-240V	
	P6X8	6.3	4000	80	F1 40°	420 - 488		

Gea Pro Comfort Ø125mm

IP 66-67		1 m	SEA SIDE SUITABLE		±15°	360		LED	DRIVER
-------------	--	-----	----------------------	--	------	-----	--	-----	--------

Code example / Exemple d'élaboration d'une référence: **AZ14-P2V8S1OUC**A

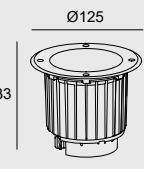
Model		W	K	CRI	Optics	Real Lm	Source	Finishes
AZ14 - Ø125mm Comfort 	P2V8	2.1	2700	80	S1 7°	116	OU ON-OFF 100-240V	CA
	P2W8	2.1	3000	80				
	P2X8	2.1	4000	80				
	P6V8	6.3	2700	80	S3 12°	286 - 333	OU ON-OFF 100-240V	
	P6W8	6.3	3000	80	M2 22°	330 - 384	DU DALI-2 120-240V	
	P6X8	6.3	4000	80	F1 34°	240 - 279		

RECESSED FLOOR LIGHTS | ENCASTRÉS DE SOL

Gea Pro Efficiency Ø185mm



Code example / Exemple d'élaboration d'une référence: **AZ15-P6V8S10UCA**

Model		W	K	CRI	Optics	Real Lm	Source	Finishes
AZ15 - Ø185mm Efficiency 	P6V8	6.3	2700	80	S1 10°	670	OU ON-OFF 100-240V	CA
	P6W8	6.3	3000	80			DU DALI-2 120-240V	
	P6X8	6.3	4000	80				
	13V8	12.6	2700	80	S3 17°	1124	OU ON-OFF 100-240V	
	13W8	12.6	3000	80	M2 26°	1411	DU DALI-2 120-240V	
	13X8	12.6	4000	80	F1 46°	1025		

Gea Pro Comfort Ø185mm



Code example / Exemple d'élaboration d'une référence: **AZ16-P6V8S10UCA**

Model		W	K	CRI	Optics	Real Lm	Source	Finishes
AZ16 - Ø185mm Comfort 	P6V8	6.3	2700	80	S1 7°	383	OU ON-OFF 100-240V	CA
	P6W8	6.3	3000	80			DU DALI-2 120-240V	
	P6X8	6.3	4000	80				
	13V8	12.6	2700	80	S3 15°	699	OU ON-OFF 100-240V	
	13W8	12.6	3000	80	M2 23°	806	DU DALI-2 120-240V	
	13X8	12.6	4000	80	F1 37°	586		

Gea Pro Efficiency Ø220mm



Code example / Exemple d'élaboration d'une référence: **AZ17-P8V8S10UCA**

Model		W	K	CRI	Optics	Real Lm	Source	Finishes
AZ17 - Ø220mm Efficiency 	P8V8	8.4	2700	80	S1 9°	996	OU ON-OFF 100-240V	CA
	P8W8	8.4	3000	80			DU DALI-2 120-240V	
	P8X8	8.4	4000	80				
	17V8	16.8	2700	80	S3 11°	1416	OU ON-OFF 100-240V	
	17W8	16.8	3000	80	M2 26°	1633	DU DALI-2 120-240V	
	17X8	16.8	4000	80	F1 45°	1186		
	P4N8	16.2	RGBW* 4000		S1 9°	328	DM** DMX RDM 120-277V	
	P9N8	28.9	RGBW* 4000		S3 11°	623	DM** DMX RDM 120-277V	
				M2 26°	717			
				F1 45°	523			

* The indicated flow corresponds to the temperature W = 4000 K

* Le flux indiqué correspond à la température W= 4 000 K

** This product may require programming by a specialist. LedsC4 offers consulting services on control systems and programming in the factory or on-site. Ask your sales agent for more info.

** Ce produit peut nécessiter une programmation par un spécialiste. LedsC4 offre des services de conseils pour les systèmes de contrôle et de programmation en usine ou sur place. Consultez votre agent commercial.

Gea Pro Comfort Ø220mm



Code exemple / Exemple d'élaboration d'une référence: **AZ18-P8V8S10UCA**

Model		W	K	CRI	Optics	Real Lm	Source	Finishes
AZ18 - Ø220mm Comfort 	P8V8	8.4	2700	80	S1 9°	664	OU ON-OFF 100-240V	CA
	P8W8	8.4	3000	80			DU DALI-2 120-240V	
	P8X8	8.4	4000	80				
	17V8	16.8	2700	80	S3 10°	944	OU ON-OFF 100-240V	
	17W8	16.8	3000	80	M2 22°	1089	DU DALI-2 120-240V	
	17X8	16.8	4000	80	F1 35°	791		
	P4N8	16.2	RGBW* 4000		S1 9°	187	DM** DMX RDM 120-277V	
	P9N8	28.9	RGBW* 4000		S3 10° M2 22° F1 35°	356 410 299	DM** DMX RDM 120-277V	

* The indicated flow corresponds to the temperature W = 4000 K

* Le flux indiqué correspond à la température W= 4 000 K

** This product may require programming by a specialist. LedsC4 offers consulting services on control systems and programming in the factory or on-site. Ask your sales agent for more info.

** Ce produit peut nécessiter une programmation par un spécialiste. LedsC4 offre des services de conseils pour les systèmes de contrôle et de programmation en usine ou sur place. Consultez votre agent commercial.

Gea Pro Efficiency Ø300mm



Code exemple / Exemple d'élaboration d'une référence: **AZ19-17V8S10UCA**

Model		W	K	CRI	Optics	Real Lm	Source	Finishes
AZ19 - Ø300mm Efficiency 	17V8	16.8	2700	80	S1 9°	1992	OU ON-OFF 120-277V	CA
	17W8	16.8	3000	80			DU DALI-2/PUSH 120-277V	
	17X8	16.8	4000	80				
	34V8	33.6	2700	80	S3 11°	2832	OU ON-OFF 100-240V	
	34W8	33.6	3000	80	M2 26°	3266	DU DALI-2/PUSH 120-277V	
	34X8	33.6	4000	80	F1 45°	2373		
	P8N8	22.8	RGBW* 4000		S1 9°	656	DM** DMX RDM 100-240V	
	17N8	46.9	RGBW* 4000		S3 11° M2 26° F1 45°	1246 1433 1046	DM** DMX RDM 100-240V	

* The indicated flow corresponds to the temperature W = 4000 K

* Le flux indiqué correspond à la température W= 4 000 K

** This product may require programming by a specialist. LedsC4 offers consulting services on control systems and programming in the factory or on-site. Ask your sales agent for more info.

** Ce produit peut nécessiter une programmation par un spécialiste. LedsC4 offre des services de conseils pour les systèmes de contrôle et de programmation en usine ou sur place. Consultez votre agent commercial.

Gea Pro Comfort Ø300mm

Code exemple / Exemple d'élaboration d'une référence: **AZ21-17V8S10UCA**

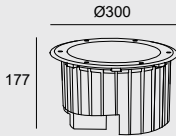
Model	W	K	CRI	Optics	Real Lm	Source	Finishes	
AZ21 - Ø300mm Comfort 	17V8	16.8	2700	80	S1 9°	1328	OU ON-OFF 120-277V	CA
	17W8	16.8	3000	80			DU DALI-2/PUSH 120-277V	
	17X8	16.8	4000	80				
	34V8	33.6	2700	80	S3 10°	1888	OU ON-OFF 100-240V	
	34W8	33.6	3000	80	M2 22°	2177	DU DALI-2/PUSH 120-277V	
	34X8	33.6	4000	80	F1 35°	1582		
	P8N8	22.8	RGBW* 4000		S1 9°	375	DM** DMX RDM 100-240V	
17N8	46.9	RGBW* 4000		S3 10°	712	DM** DMX RDM 100-240V		
				M2 22°	819			
				F1 35°	598			

* The indicated flow corresponds to the temperature W = 4000 K

* Le flux indiqué correspond à la température W= 4 000 K

** This product may require programming by a specialist. LedsC4 offers consulting services on control systems and programming in the factory or on-site. Ask your sales agent for more info.

** Ce produit peut nécessiter une programmation par un spécialiste. LedsC4 offre des services de conseils pour les systèmes de contrôle et de programmation en usine ou sur place. Consultez votre agent commercial.

**Gea Power LED Pro
ON-OFF**
**Gea Power LED Pro
DALI**

Fixing accessories

Accessoires de fixation

 Recess case
Boîtier d'encastrement

Included

Included

Connection accessories

Accessoires de connexion

 IP68 connector (1 input + 1 output)
 Ø 6–17 mm, 5 poles
 Connecteur IP68 (1 entrée + 1 sortie)
 Ø 6 - 17 mm, 5 pôles

-

71-E361-00-00
 IP68 anti-condensation connector
 (1 input + 1 output) Ø 5.5–12 mm, 4 poles
 Connecteur anticondensation IP68
 (1 entrée + 1 sortie) Ø 5,5 - 12 mm, 4 pôles
71-E112-00-00

-

 IP68 anti-condensation connector (1 input
 + 3 outputs) Ø 5.5–12 mm, 4 poles
 Connecteur anticondensation IP68
 (1 entrée + 3 sorties) Ø 5,5 - 12 mm, 4 pôles
71-E122-00-00

-

 IP68 connection box (1 input + 5 outputs)
 Ø 6.5–11 mm, 6 poles
 Boîtier de raccordement IP67 (1 entrée
 + 5 sorties) Ø 6,5 - 11 mm, 6 pôles
71-9199-05-05**71-9199-05-05**
 IP68 connector (1 input + 1 output)
 Ø 5.5–11.5 mm, 4 poles
 Connecteur IP68 (1 entrée + 1 sortie)
 Ø 5,5 - 11,5 mm, 4 pôles
71-E512-00-00

-

 IP68 connector (1 input + 2 outputs)
 Ø 5.5–11.5 mm, 3 poles
 Connecteur IP68 (1 entrée + 2 sorties)
 Ø 5,5 - 11,5 mm, 3 pôles
71-E513-00-00

-

IK
10



50000h
L80 B20

2
MacAdam

BODY MAT
AISI316, POLI

DIF MAT
GLA



Solution with multiple accessories,
ideal for vegetation
Solution multi-accessoires, idéale
pour la végétation



Maximum durability Durabilité maximale

Double protective case to insulate the luminaire's electronics and offer greater protection, preventing the LED or driver from being damaged.

Carcasse double protection qui permet d'isoler les composants électroniques du luminaire pour une meilleure protection, évitant ainsi l'endommagement de la LED ou du driver.

**Gea Cob
125mm**

IP 65-67 | 1 m | BREEAM | ±15° | 360° | SEA SIDE SUITABLE

CA

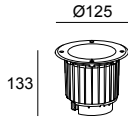

LED						
K	CRI	W Total	Real Lm	Optics	Code	
2700	80	10.5	869	17°; 53°	55-9906 - CA - CK	ON-OFF 100-240V
3000	80	10.5	869	17°; 53°	55-9906 - CA - CL	ON-OFF 100-240V
4000	80	10.5	934	17°; 53°	55-9906 - CA - CM	ON-OFF 100-240V

**Gea Cob
185mm**

IP 65-67 | 1 m | BREEAM | ±15° | 360° | SEA SIDE SUITABLE

CA

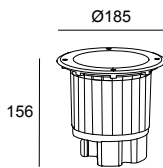
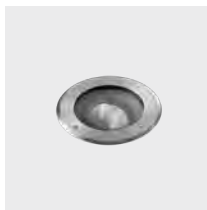

LED						
K	CRI	W Total	Real Lm	Optics	Code	
2700	80	17.6	1630	21°; 54°	55-9907 - CA - CK 55-E078	ON-OFF 100-240V DALI-2 100-240V
3000	80	17.6	1630	21°; 54°	55-9907 - CA - CL 55-E078	ON-OFF 100-240V DALI-2 100-240V
4000	80	17.6	1752	21°; 54°	55-9907 - CA - CM 55-E078	ON-OFF 100-240V DALI-2 100-240V

**Gea Cob
220mm**

IP 65-67 | 1 m | BREEAM | ±15° | 360° | SEA SIDE SUITABLE

CA

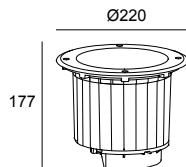

LED						
K	CRI	W Total	Real Lm	Optics	Code	
2700	80	26.7	2262	18°; 53°	55-9909 - CA - CK 55-E079	ON-OFF 100-240V DALI-2 100-240V
3000	80	26.7	2262	18°; 53°	55-9909 - CA - CL 55-E079	ON-OFF 100-240V DALI-2 100-240V
4000	80	26.7	2423	18°; 53°	55-9909 - CA - CM 55-E079	ON-OFF 100-240V DALI-2 100-240V



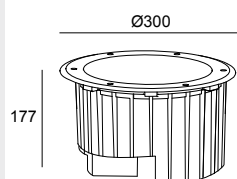

**Gea Cob
300mm**

IP 65-67 | 1 m | BREEAM | ±15° | 360° | SEA SIDE SUITABLE

CA



LED						
K	CRI	W Total	Real Lm	Optics	Code	
2700	80	35	3681	18°; 51°	55-9972 - CA - CK 55-E080	ON-OFF 100-240V DALI-2 100-240V
3000	80	35	3681	18°; 51°	55-9972 - CA - CL 55-E080	ON-OFF 100-240V DALI-2 100-240V
4000	80	35	3927	18°; 51°	55-9972 - CA - CM 55-E080	ON-OFF 100-240V DALI-2 100-240V

Gea Cob 125mm	Gea Cob 185mm	Gea Cob 223mm	Gea Cob 300mm
			







Lens accessories
Accessoires optiques

	Honeycomb panel Panneau en nid d'abeille	Included	Included	Included	Included
	Asymmetric anti-glare Anti-éblouissement asymétrique	Included	Included	Included	Included
	Set of 2 reflectors (17° and 53°) Set de 2 réflecteurs (17° et 53°)	Included	-	-	
	Set of 2 reflectors (18° and 51°) Set de 2 réflecteurs (18° et 51°)	-	-		Included
	Set of 2 reflectors (18° and 53°) Set de 2 réflecteurs (18° et 53°)	-	-	Included	
	Set of 2 reflectors (21° and 54°) Set de 2 réflecteurs (21° et 54°)	-	Included	-	

Fixing accessories
Accessoires de fixation

	Recess case Boîtier d'encastrement	Included	Included	Included	Included
-------------------------------------------------------------------------------------	---------------------------------------	----------	----------	----------	----------

Connection accessories
Accessoires de connexion

	IP68 connector (1 input + 1 output) Ø 5.5-11.5 mm, 4 poles Connecteur IP68 (1 entrée + 1 sortie) Ø 5,5 - 11,5 mm, 4 pôles	71-E512-00-00	71-E512-00-00	71-E512-00-00	71-E512-00-00
Not for DALI					
	IP68 connector (1 input + 1 output) Ø 6-17 mm, 5 poles Connecteur IP68 (1 entrée + 1 sortie) Ø 6 - 17 mm, 5 pôles	-	71-E361-00-00	71-E361-00-00	71-E361-00-00
Not for ON-OFF					
	IP68 connector (1 input + 2 outputs) Ø 5.5-11.5 mm, 3 poles Connecteur IP68 (1 entrée + 2 sorties) Ø 5,5 - 11,5 mm, 3 pôles	71-E513-00-00	71-E513-00-00	71-E513-00-00	71-E513-00-00
Not for DALI					
	IP68 anti-condensation connector (1 input + 1 output) Ø 5.5-12 mm, 4 poles Connecteur anticondensation IP68 (1 entrée + 1 sortie) Ø 5,5 - 12 mm, 4 pôles	71-E112-00-00	71-E112-00-00	71-E112-00-00	71-E112-00-00
Not for DALI					
	IP68 anti-condensation connector (1 input + 3 outputs) Ø 5.5-12 mm, 4 poles Connecteur anticondensation IP68 (1 entrée + 3 sorties) Ø 5,5 - 12 mm, 4 pôles	71-E122-00-00	71-E122-00-00	71-E122-00-00	71-E122-00-00
Not for DALI					
	IP68 connection box (1 input + 5 outputs) Ø 6.5-11 mm, 6 poles Boîtier de raccordement IP67 (1 entrée + 5 sorties) Ø 6,5 - 11 mm, 6 pôles	71-9199-05-05	71-9199-05-05	71-9199-05-05	71-9199-05-05

Gea Wall Washer

IK		50000h	3	BODY MAT	DIF MAT
10		L80 B20	MacAdam	AISI316,POLI	GLA



Solution for wash-lighting façades
 Solution lèche-mur pour façades

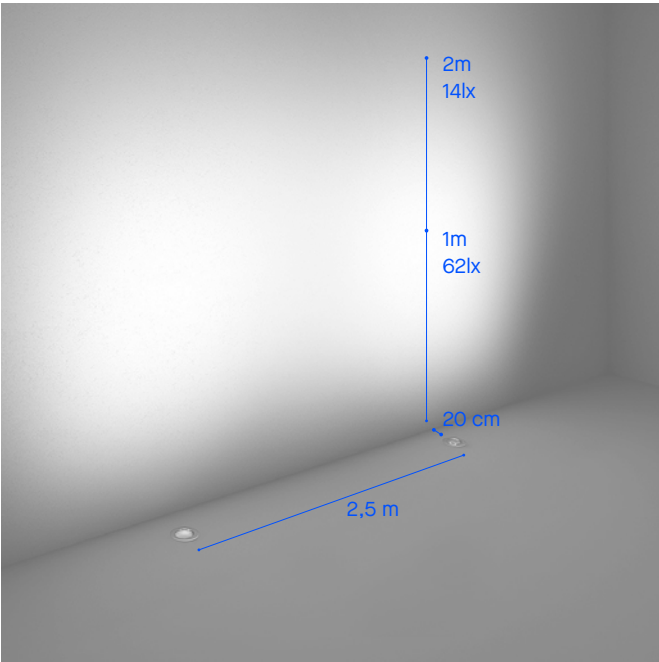

Ø 185 mm (55-9908-CA-CM)

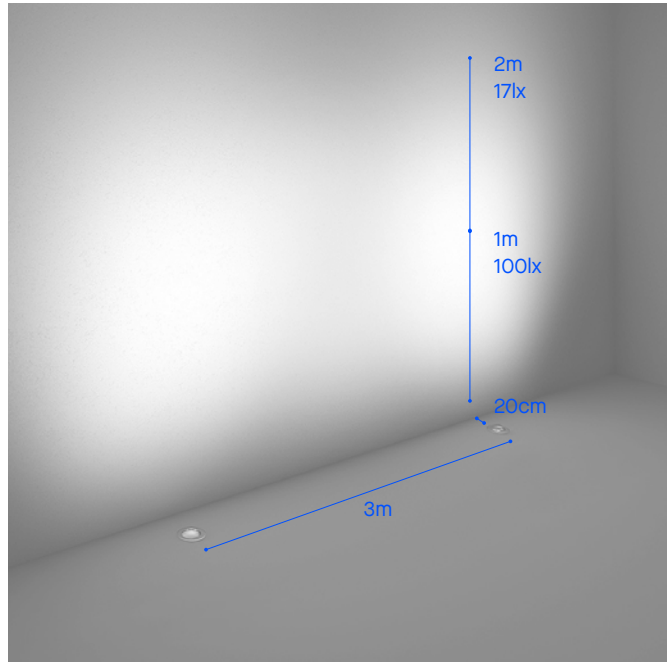

Ø 223 mm (55-9910-CA-CM)

Gea Wall Washer 185mm



CA

OUTDOOR

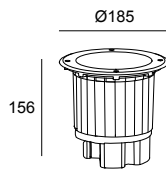

LED							
K	CRI	W Total	Real Lm	Optics	Code		
2700	80	18.5	618	81°	55-E081 - CA - CK		DALI-2 100-240V
3000	80	18.5	618	81°	55-9908 55-E081 - CA - CL		ON-OFF 100-240V DALI-2 100-240V
4000	80	18.5	711	81°	55-9908 55-E081 - CA - CM		ON-OFF 100-240V DALI-2 100-240V

Gea Wall Washer 220mm



CA

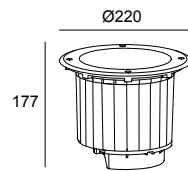

LED							
K	CRI	W Total	Real Lm	Optics	Code		
2700	80	27.5	1008	78°	55-E082 - CA - CK		DALI-2 100-240V
3000	80	27.5	1008	78°	55-9910 55-E082 - CA - CL		ON-OFF 100-240V DALI-2 100-240V
4000	80	27.5	1109	78°	55-9910 55-E082 - CA - CM		ON-OFF 100-240V DALI-2 100-240V

Gea Wall Washer
ON-OFF

Gea Wall Washer
DALI

Fixing accessories Accessoires de fixation



Recess case
Boîtier d'encastrement

Included

Included

Connection accessories Accessoires de connexion



IP68 connector (1 input + 1 output) Ø 5.5-11.5 mm, 4 poles
Connecteur IP68 (1 entrée + 1 sortie) Ø 5,5 - 11,5 mm, 4 pôles

71-E512-00-00

-



IP68 connector (1 input + 1 output) Ø 6-17 mm, 5 poles
Connecteur IP68 (1 entrée + 1 sortie) Ø 6 - 17 mm, 5 pôles

-

71-E361-00-00



IP68 connector (1 input + 2 outputs) Ø 5.5-11.5 mm, 3 poles
Connecteur IP68 (1 entrée + 2 sorties) Ø 5,5 - 11,5 mm, 3 pôles

71-E513-00-00

-



IP68 anti-condensation connector (1 input + 1 output)
Ø 5.5-12 mm, 4 poles
Connecteur anticondensation IP68 (1 entrée + 1 sortie)
Ø 5,5 - 12 mm, 4 pôles

71-E112-00-00

-



IP68 anti-condensation connector (1 input + 3 outputs)
Ø 5.5-12 mm, 4 poles
Connecteur anticondensation IP68 (1 entrée + 3 sorties)
Ø 5,5 - 12 mm, 4 pôles

71-E122-00-00

-



IP68 connection box (1 input + 5 outputs) Ø 6.5-11 mm, 6 poles
Boîtier de raccordement IP67 (1 entrée + 5 sorties)
Ø 6,5 - 11 mm, 6 pôles

71-9199-05-05

71-9199-05-05

RECESSED FLOOR LIGHTS | ENCASTRÉS DE SOL

Gea Compact

IK
10



50000h
L80 B20

3
MacAdam

BODY MAT
AISI316,POLI

DIF MAT
GLA



Solution for shallow floors
 Solution pour les sols peu profonds



130 mm



180 mm



Gea Compact Uplight Round 130mm



CA

OUTDOOR

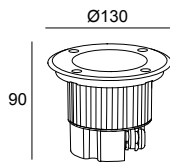

LED							
K	CRI	W Total	Real Lm	Optics	Code		
3000	80	8.9	460	26°	55-9663 - CA - CL	ON-OFF	100-240V
4000	80	8.9	460	26°	55-9663 - CA - CM	ON-OFF	100-240V

Gea Compact Uplight Round 180mm



CA

RECESSED FLOOR LIGHTS | ENCASTRÉS DE SOL

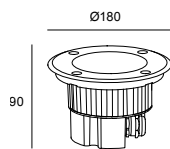

LED							
K	CRI	W Total	Real Lm	Optics	Code		
3000	80	11	796	17°	55-9665 - CA - CL	ON-OFF	100-240V
3000	80	22	1101	14°	55-9667 - CA - CL	ON-OFF	100-240V
4000	80	11	837	17°	55-9665 - CA - 37	ON-OFF	100-240V
4000	80	22	1167	14°	55-9667 - CA - CM	ON-OFF	100-240V

Lens accessories Accessoires optiques



Diffuser filter
Filtre diffuseur

Included

Included

Fixing accessories Accessoires de fixation



Recess case
Boîtier d'encastrement

Included

Included

BODY MAT	DIF MAT	50000h	3
AISI316,POLI	GLA	L80 B20	MacAdam



Signage lighting solution Solution d'éclairage de signalisation

Gea Signaling 12V AC/DC 45mm

IP 65-67	IK 05			SEA SIDE SUITABLE			
-------------	----------	--	--	----------------------	--	--	--

54

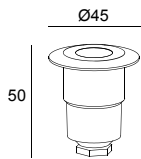

LED						12V AC/DC
K	CRI	W	Real Lm	Optics	Code	
3000	80	0.5	12	68°	55-9768 - 54 - CL	
4000	80	0.5	12	68°	55-9768 - 54 - T2	

35 5-30 mm

Gea Signaling 12V AC/DC 60mm

IP 65-67	IK 05			SEA SIDE SUITABLE			
-------------	----------	--	--	----------------------	--	--	--

54

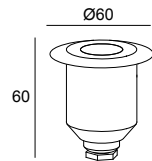

LED						12V AC/DC
K	CRI	W	Real Lm	Optics	Code	
3000	80	1	23	68°	55-9769 - 54 - CL	
4000	80	1	23	68°	55-9769 - 54 - T2	

50 5-30 mm

Gea Signaling 100-240V 60mm

IP 65-67	IK 10		LOW FLICKER		SEA SIDE SUITABLE		
-------------	----------	--	----------------	--	----------------------	--	--

54

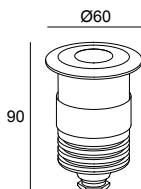

LED						
K	CRI	W Total	Real Lm	Optics	Code	
3000	80	2.2	52	96°	55-9620 - 54 - CL	ON-OFF 100-240V
4000	80	2.2	52	96°	55-9620 - 54 - T2	ON-OFF 100-240V

50 0-20 mm

Gea Signaling
12V AC/DC

Gea Signaling
100-240V



Power supplies
Sources d'alimentation

P. 985



ON-OFF
IP20

71-B677-00-00
Max. 20W

-

Lens accessories
Accessoires optiques



3000K diffuser
Diffuseur 3 000 K

-

Included



Colour filters
Filtres de couleur

Included

Included



3700K diffuser
Diffuseur 3 700 K

Included

-

Fixing accessories
Accessoires de fixation



Recess case
Boîtier d'encastrement

Included

Included

Connection accessories
Accessoires de connexion



IP67 connector (1 input + 1 output) Ø 5.5–7.5 mm, 3 poles
Connecteur IP67 (1 entrée + 1 sortie) Ø 5,5 - 7,5 mm, 3 pôles

71-E510-00-00

71-E510-00-00



IP67 connector (1 input + 2 outputs) Ø 5.5–7.5 mm, 3 poles
Connecteur IP67 (1 entrée + 2 sorties) Ø 5,5 - 7,5 mm, 3 pôles

71-E511-00-00

71-E511-00-00



IP68 connector (1 input + 1 output) Ø 5.5–11.5 mm, 4 poles
Connecteur IP68 (1 entrée + 1 sortie) Ø 5,5 - 11,5 mm, 4 pôles

71-E512-00-00

71-E512-00-00



IP68 connector (1 input + 2 outputs) Ø 5.5–11.5 mm, 3 poles
Connecteur IP68 (1 entrée + 2 sorties) Ø 5,5 - 11,5 mm, 3 pôles

71-E513-00-00

71-E513-00-00



IP68 anti-condensation connector (1 input + 1 output)
Ø 5.5–12 mm, 4 poles
Connecteur anticondensation IP68 (1 entrée + 1 sortie)
Ø 5,5 - 12 mm, 4 pôles

71-E112-00-00

71-E112-00-00



IP68 anti-condensation connector (1 input + 3 outputs)
Ø 5.5–12 mm, 4 poles
Connecteur anticondensation IP68 (1 entrée + 3 sorties)
Ø 5,5 - 12 mm, 4 pôles

71-E122-00-00

71-E122-00-00



IP67 connection box (1 input + 2 outputs)
Ø 6–7.5 mm, 3 poles
Boîtier de raccordement IP67 (1 entrée + 2 sorties)
Ø 6 - 7,5 mm, 3 pôles

71-9262-05-05

71-9262-05-05



IP68 connection box (1 input + 5 outputs)
Ø 6.5–11 mm, 6 poles
Boîtier de raccordement IP67 (1 entrée + 5 sorties)
Ø 6,5 - 11 mm, 6 pôles

71-9199-05-05

71-9199-05-05

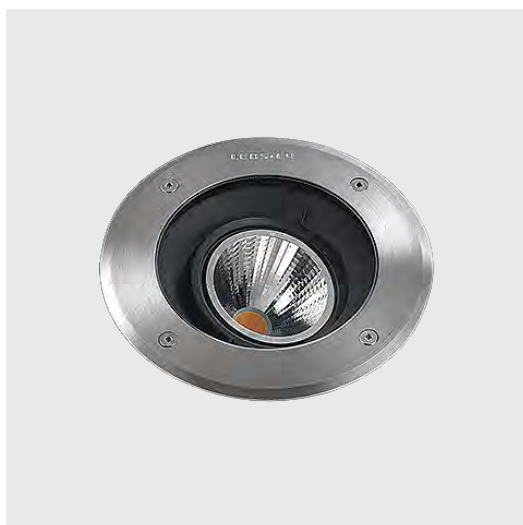

Solution that can be installed
directly in the ground, without
using concrete

Solution à installer directement
en terre, sans utiliser de béton





Gea Technopolymer Cob 125mm

IK 10 SEA SIDE SUITABLE IP 65-67 BREEAM 1 m 15° 360° LED DRIVER CA

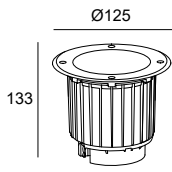
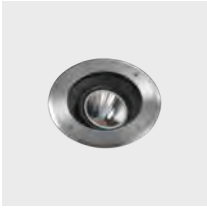

LED						
K	CRI	W Total	Real Lm	Optics	Code	
3000	80	7.7	568	17°;53°	55-E083 - CA - CL	ON-OFF 100-240V

Gea Technopolymer Cob 185mm

IK 10 SEA SIDE SUITABLE IP 65-67 BREEAM 1 m 15° 360° LED DRIVER CA

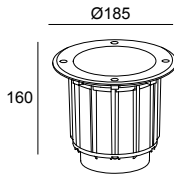

LED						
K	CRI	W Total	Real Lm	Optics	Code	
3000	80	12.7	1276	21°;54°	55-E038 - CA - CL	ON-OFF 100-240V

Gea Technopolymer GU10 Square

IP 65-67

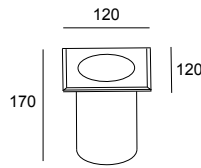

GU10	
W	Code
Max. 8	55-9281 - CA - 37

Gea Technopolymer GU10 Round

IP 65-67

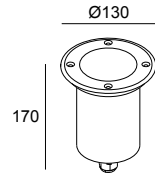

GU10	
W	Code
Max. 8	55-9280 - CA - 37

Gea Technopolymer GU10 Round Adjustable

IP 65-67 ±15°

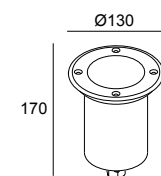

GU10	
W	Code
Max. 8	55-9380 - CA - 37

	Gea Technopolymer Cob 125mm	Gea Technopolymer Cob 185mm	Gea Technopolymer GU10
--	--------------------------------	--------------------------------	---------------------------

Lens accessories
Accessoires optiques

	Honeycomb panel Panneau en nid d'abeille	Included	Included	-
	Asymmetric filter Filtre asymétrique	Included	Included	-
	Set of 2 reflectors (17° and 53°) Set de 2 réflecteurs (17° et 53°)	Included	-	-
	Set of 2 reflectors (21° and 54°) Set de 2 réflecteurs (21° et 54°)	-	Included	-

Fixing accessories
Accessoires de fixation

	Recess case Boîtier d'encastrement	Included	Included	Included
-----------------------------------------------------------------------------------	---------------------------------------	----------	----------	----------

Connection accessories
Accessoires de connexion

	IP68 connector (1 input + 1 output) Ø 5.5–11.5 mm, 4 poles Connecteur IP68 (1 entrée + 1 sortie) Ø 5,5 - 11,5 mm, 4 pôles	71-E512-00-00	71-E512-00-00	-
	IP68 connector (1 input + 2 outputs) Ø 5.5–11.5 mm, 3 poles Connecteur IP68 (1 entrée + 2 sorties) Ø 5,5 - 11,5 mm, 3 pôles	71-E513-00-00	71-E513-00-00	-
	IP68 anti-condensation connector (1 input + 1 output) Ø 5.5–12 mm, 4 poles Connecteur anticondensation IP68 (1 entrée + 1 sortie) Ø 5,5 - 12 mm, 4 pôles	71-E112-00-00	71-E112-00-00	-
	IP68 anti-condensation connector (1 input + 3 outputs) Ø 5.5–12 mm, 4 poles Connecteur anticondensation IP68 (1 entrée + 3 sorties) Ø 5,5 - 12 mm, 4 pôles	71-E122-00-00	71-E122-00-00	-
	IP68 connection box (1 input + 5 outputs) Ø 6.5–11 mm, 6 poles Boîtier de raccordement IP67 (1 entrée + 5 sorties) Ø 6,5 - 11 mm, 6 pôles	71-9199-05-05	71-9199-05-05	-



+ Kay



An essential with every detail taken care of Essentiel dans le souci du détail

This collection is ideal for projects needing an affordable solution without sacrificing maximum reliability and visual comfort. Kay's lens group cannot be tilted, but its included accessories and the quality of its materials make it an ideal recessed floor light collection for most projects.

Cette collection est idéale pour les projets qui nécessitent une solution économique sans renoncer au maximum de fiabilité et de confort visuel. Kay ne permet pas d'incliner le bloc optique, mais les accessoires inclus et la qualité de ses matériaux en font un encastré de sol idéal pour la plupart des projets.

185 mm



125 mm



80 mm



Kay 80mm

BODY MAT AL, AISI316	DIF MAT GL TMP		50000h L80 B20	3 MacAdam	IP 65	IK 10	BREEAM	 1 m	 SEA SIDE SUITABLE			
-------------------------	-------------------	--	-------------------	--------------	----------	----------	--------	---------	--------------------------	--	--	--

CA

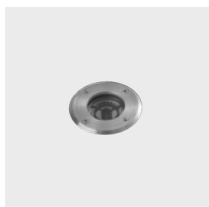

LED							
K	CRI	W Total	Real Lm	Optics	Code		
3000	80	5.7	400	30°	55-E010 - CA - CL		ON-OFF 100-240V

Kay 125mm

BODY MAT AL, AISI316	DIF MAT GL TMP		50000h L80 B20	3 MacAdam	IP 65-67	IK 10	BREEAM		SEA SIDE SUITABLE			
-------------------------	-------------------	--	-------------------	--------------	-------------	----------	--------	--	----------------------	--	--	--

CA

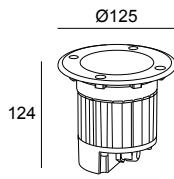

LED							
K	CRI	W Total	Real Lm	Optics	Code		
3000	80	11.5	925	34°	55-E011 - CA - CL	ON-OFF	100-240V

Kay 185mm

BODY MAT AL, AISI316	DIF MAT GL TMP		50000h L80 B20	3 MacAdam	IP 65-67	IK 10	BREEAM		SEA SIDE SUITABLE			
-------------------------	-------------------	--	-------------------	--------------	-------------	----------	--------	--	----------------------	--	--	--

CA

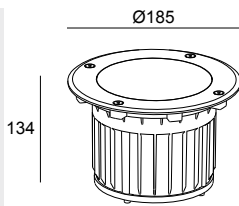

LED							
K	CRI	W Total	Real Lm	Optics	Code		
3000	80	23.6	1890	35°	55-E020 - CA - CL	ON-OFF	100-240V

Lens accessories Accessoires optiques



Anti-glare
Anti-éblouissement

Included



Wall washer diffuser
Diffuseur lèche-mur

Included

Fixing accessories Accessoires de fixation



Recess case
Boîtier d'encastrement

Included

Connection accessories Accessoires de connexion



IP68 connector (1 input + 1 output)
Ø 5.5–11.5 mm, 4 poles
Connecteur IP68 (1 entrée + 1 sortie)
Ø 5,5 - 11,5 mm, 4 pôles

71-E512-00-00



IP68 connector (1 input + 2 outputs)
Ø 5.5–11.5 mm, 3 poles
Connecteur IP68 (1 entrée + 2 sorties)
Ø 5,5 - 11,5 mm, 3 pôles

71-E513-00-00



IP68 anti-condensation connector (1 input + 1 output)
Ø 5.5–12 mm, 4 poles
Connecteur anticondensation IP68 (1 entrée + 1 sortie)
Ø 5,5 - 12 mm, 4 pôles

71-E112-00-00



IP68 anti-condensation connector (1 input + 3 outputs)
Ø 5.5–12 mm, 4 poles
Connecteur anticondensation IP68 (1 entrée + 3 sorties)
Ø 5,5 - 12 mm, 4 pôles

71-E122-00-00



IP68 connection box (1 input + 5 outputs)
Ø 6.5–11 mm, 6 poles
Boîtier de raccordement IP67 (1 entrée + 5 sorties)
Ø 6,5 - 11 mm, 6 pôles

71-9199-05-05



+ Ios



Visual comfort in a profile integrated into the architecture

Confort visuel dans un profilé intégré à l'architecture

Featuring a compact design, the IOS recessed floor lights are ideal for lighting small features, such as entrances, columns or sculptures, providing a controlled, comfortable light beam from a barely visible profile.

Grâce à leur conception compacte, les encastrés de sol IOS sont idéaux pour éclairer de petits éléments tels que des entrées, des colonnes ou des sculptures, car ils émettent un faisceau de lumière contrôlé et confortable alors que leur profilé passe pratiquement inaperçu.

Symmetrical models with anti-glare honeycomb panel

Modèles symétriques avec grille en nid d'abeille anti-éblouissement

Asymmetrical model with sunken LEDs

Modèle asymétrique avec disposition enfoncée des LED

30 mm



50 mm



77 mm





Symmetrical and asymmetrical light with high visual comfort
Éclairage symétrique et asymétrique à grand confort visuel

Symmetrical light
Éclairage symétrique

Mid-angle beam that's ideal for accent lighting.
Faisceau lumineux à angle moyen, idéal pour l'éclairage d'accentuation.



Asymmetrical light
Éclairage asymétrique

Side-facing light beam that's ideal for wash-lighting small façades.
Faisceau lumineux orienté vers un côté, idéal pour les effets lèche-murs sur petites façades.



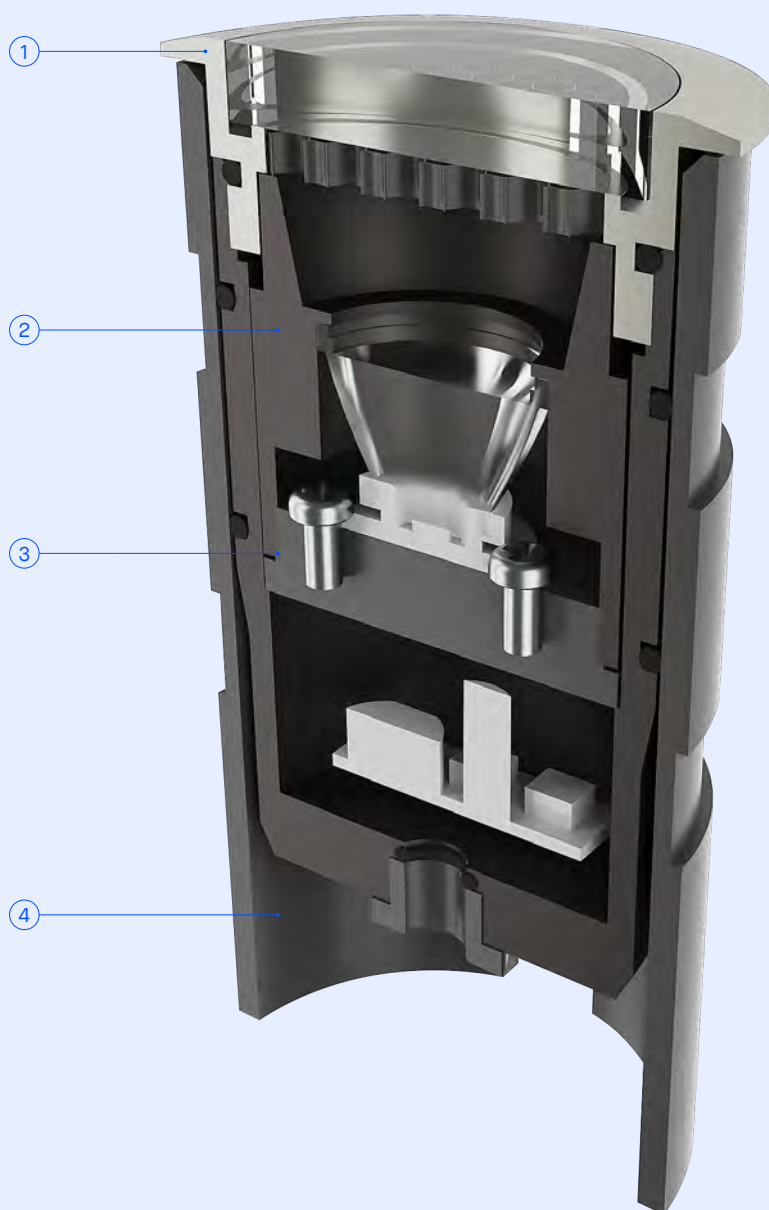

① **AISI16 stainless steel frame** that ensures the product's durability in marine environments.
Collerette en acier inoxydable AISI16 qui assure la durabilité du produit en milieu marin.

② **The sunken LEDs** guarantee excellent visual comfort.
La disposition enfoncée des LED garantit un grand confort visuel.

③ **Body made of high-purity turned aluminium** that maximises the product's lifespan.
Corps en aluminium tourné de haute pureté qui maximise la durée de vie utile du produit.

④ **Special anti-opening cable glands** that ensure the tightness and reliability of the luminaire.
Presse-étoupe spécial anti-ouverture qui garantit l'étanchéité et la fiabilité du luminaire.

BODY MAT	DIF MAT		50000h	3
AISI316	GLA		L80 B20	MacAdam

Ios Symmetrical Ø30mm

IP	IK			SEA SIDE SUITABLE			
65-67	05	2 m	DIM				

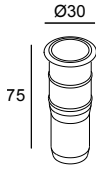

LED							24-48 VDC
K	CRI	W	Real Lm	Optics	Code		
3000	80	2	94	29°	55-E148 - CA - CL		

CA

Ios Symmetrical Ø50mm

IP	IK			SEA SIDE SUITABLE			
65-67	10	2 m	DIM				

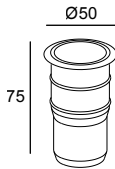

LED							24-48 VDC
K	CRI	W	Real Lm	Optics	Code		
3000	80	4	185	21°	55-E149 - CA - CL		

CA

Ios Asymmetrical Ø77mm

IP	IK			SEA SIDE SUITABLE			
65-67	10	2 m	DIM				

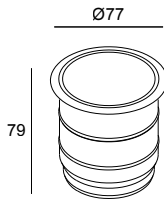

LED							24-48 VDC
K	CRI	W	Real Lm	Optics	Code		
3000	80	5.8	203	38°	55-E150 - CA - CL		

CA



	ON-OFF IP20	Max. 20W	71-B650-00-00		ON-OFF IP67	Max. 30W	71-B644-00-00 ✖	
		Max. 30W	71-B640-00-00				Max. 60W	71-B645-00-00
		Max. 100W	71-B641-00-00				Max. 100W	71-B646-00-00

Fixing accessories
Accessoires de fixation

	Recess case Boîtier d'encastrement	Included
--	---------------------------------------	----------

Connection accessories
Accessoires de connexion

	IP67 connector (1 input + 1 output) Ø 5.5–7.5 mm, 3 poles Connecteur IP67 (1 entrée + 1 sortie) Ø 5,5 - 7,5 mm, 3 pôles	71-E510-00-00
	IP67 connector (1 input + 2 outputs) Ø 5.5–7.5 mm, 3 poles Connecteur IP67 (1 entrée + 2 sorties) Ø 5,5 - 7,5 mm, 3 pôles	71-E511-00-00
	IP68 connector (1 input + 1 output) Ø 5.5–11.5 mm, 4 poles Connecteur IP68 (1 entrée + 1 sortie) Ø 5,5 - 11,5 mm, 4 pôles	71-E512-00-00
	IP68 connector (1 input + 2 outputs) Ø 5.5–11.5 mm, 3 poles Connecteur IP68 (1 entrée + 2 sorties) Ø 5,5 - 11,5 mm, 3 pôles	71-E513-00-00
	IP68 anti-condensation connector (1 input + 1 output) Ø 5.5–12 mm, 4 poles Connecteur anticondensation IP68 (1 entrée + 1 sortie) Ø 5,5 - 12 mm, 4 pôles	71-E112-00-00
	IP68 anti-condensation connector (1 input + 3 outputs) Ø 5.5–12 mm, 4 poles Connecteur anticondensation IP68 (1 entrée + 3 sorties) Ø 5,5 - 12 mm, 4 pôles	71-E122-00-00
	IP68 connection box (1 input + 5 outputs) Ø 6.5–11 mm, 6 poles Boîtier de raccordement IP67 (1 entrée + 5 sorties) Ø 6,5 - 11 mm, 6 pôles	71-9199-05-05

Rim



+ Rim



Quality and resistance in spot lighting Qualité et résistance dans l'éclairage par points lumineux

Point-of-light signage lighting is perfect for highlighting certain strategic areas and for alerting when there are steps, slopes or areas of water. Rim's versatility makes it an ideal option for this type of use, in projects requiring outstanding quality and resistance.

L'éclairage signalétique par points lumineux est parfait pour mettre en évidence certaines zones stratégiques et pour avertir de la présence de marches, de pentes ou de plans d'eau. La polyvalence de Rim en fait une option idéale pour les projets de ce type, qui exigent un niveau exceptionnel de qualité et de résistance.

Ultra compact with only 20 mm diameter
Ultra-compact avec un diamètre de 20 mm seulement

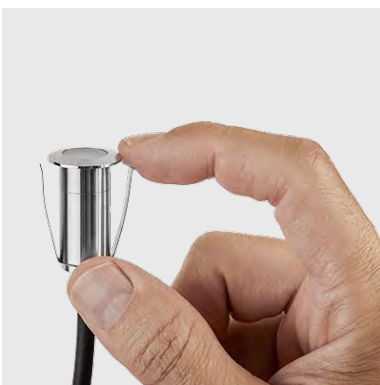

Wall or ground installation
Installation au mur ou au sol



**Rim
20mm**

BODY MAT
AISI316

DIF MAT
GLA



50000h
L80 B20

PWM

IP
65-67

IK
10

3
MacAdam

1 m

SEA SIDE
SUITABLE



CA

OUTDOOR

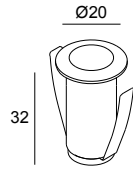
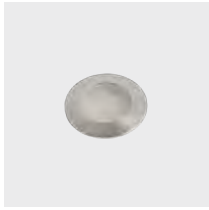

LED					24VDC
K	CRI	W	Real Lm	Code	
2700	80	0.5	4	55-E006 - CA - CK	
3000	80	0.5	3	55-E006 - CA - CL	
4000	80	0.5	4	55-E006 - CA - CM	

**Rim
46mm**

BODY MAT
AISI316

DIF MAT
GLA



50000h
L80 B20

PWM

IP
65-67

IK
10

1 m

SEA SIDE
SUITABLE



CA

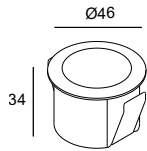

LED					24VDC
K	CRI	W	Real Lm	Code	
2700	80	1	17	55-E151 - CA - CK	
3000	80	1	17	55-E151 - CA - CL	
4000	80	1	17	55-E151 - CA - CM	
Blue		1	3	55-E151 - CA - 11	

Power supplies

P. 985

Sources d'alimentationON-OFF
IP20

Max. 20W

71-B640-00-00ON-OFF
IP67

Max. 30W

71-B644-00-00

Max. 30W

71-B650-00-00**Fixing accessories****Accessoires de fixation**Recess case
Boîtier d'encastrement

Included

Connection accessories**Accessoires de connexion**IP67 connector (1 input + 1 output)
Ø 5.5–7.5 mm, 3 poles
Connecteur IP67 (1 entrée + 1 sortie)
Ø 5,5 - 7,5 mm, 3 pôles**71-E510-00-00**IP67 connector (1 input + 2 outputs)
Ø 5.5–7.5 mm, 3 poles
Connecteur IP67 (1 entrée + 2 sorties)
Ø 5,5 - 7,5 mm, 3 pôles**71-E511-00-00**IP68 connector (1 input + 1 output)
Ø 5.5–11.5 mm, 4 poles
Connecteur IP68 (1 entrée + 1 sortie)
Ø 5,5 - 11,5 mm, 4 pôles**71-E512-00-00**IP68 connector (1 input + 2 outputs) Ø 5.5–11.5 mm, 3 poles
Connecteur IP68 (1 entrée + 2 sorties) Ø 5,5 - 11,5 mm, 3 pôles**71-E513-00-00**IP68 anti-condensation connector (1 input + 1 output)
Ø 5.5–12 mm, 4 poles
Connecteur anticondensation IP68 (1 entrée + 1 sortie)
Ø 5,5 - 12 mm, 4 pôles**71-E112-00-00**IP68 anti-condensation connector (1 input + 3 outputs)
Ø 5.5–12 mm, 4 poles
Connecteur anticondensation IP68 (1 entrée + 3 sorties)
Ø 5,5 - 12 mm, 4 pôles**71-E122-00-00**





Glare-free signage Signalisation sans éblouissement

Signage lighting with a light effect on the ground is ideal for guiding pedestrians in transit areas. Traditional solutions involve miniature luminaires that guide users without blinding. Pixel takes this a step further and does so with excellent visual comfort and total robustness as it is even suitable for vehicle transit areas.

L'éclairage signalétique par points lumineux au sol est idéal pour orienter les piétons dans une zone de passage. Les modèles traditionnels proposent des luminaires de petite taille qui guident sans éblouir. Pixel va plus loin en alliant grand confort visuel et robustesse totale, puisqu'il est même adapté aux zones de circulation de véhicules.



New metallic finishes Nouvelles finitions métalliques



Stainless Steel
Acier inoxydable



Golden laton
Laton doré



Burnished chrome
Chrome bruni

Variety of lighting effects Nombreux effets de lumière



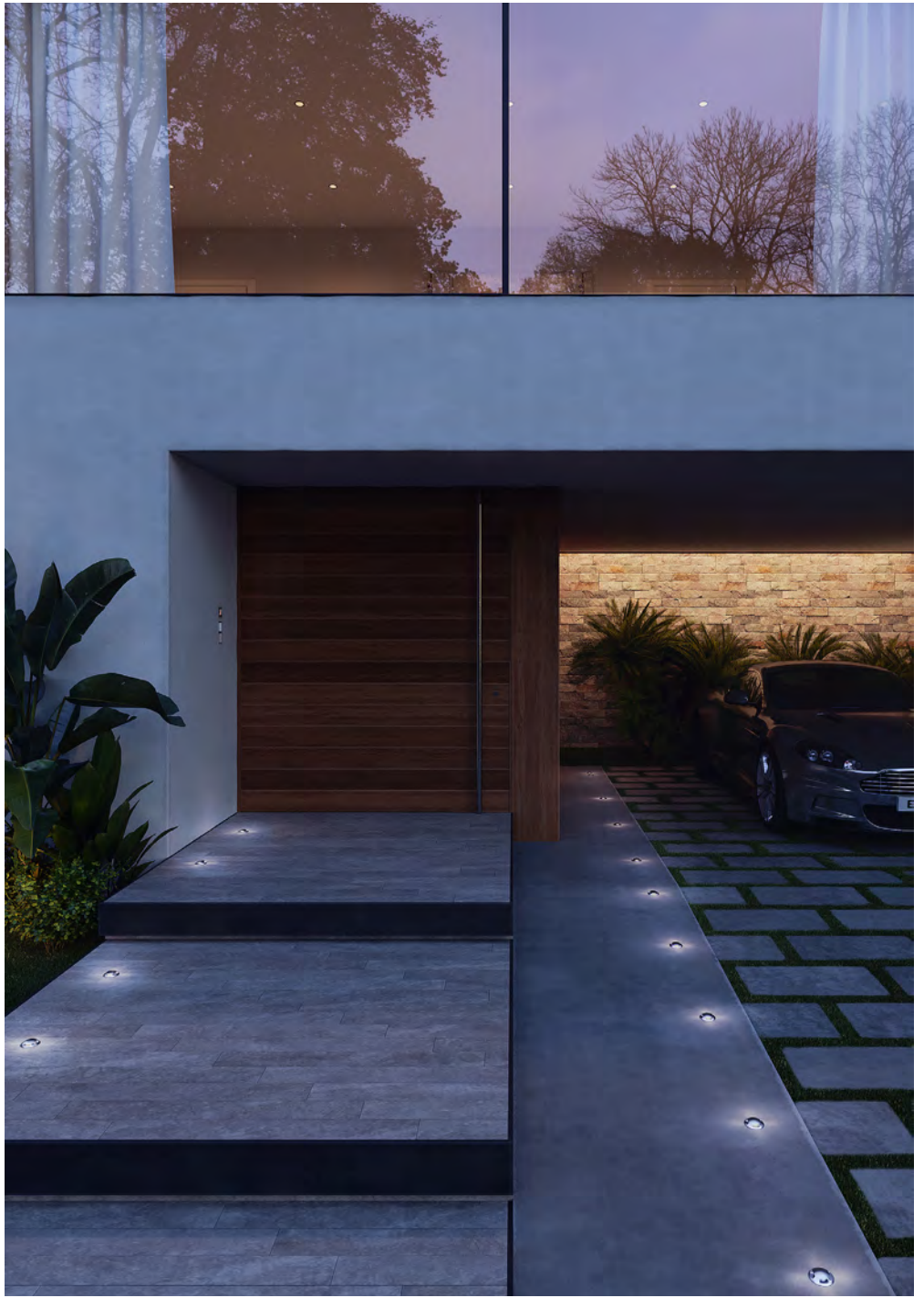

Maximum visual comfort
Maximum de confort visuel



Hidden diffuser to light without blinding.
Diffuseur dissimulé pour éclairer sans éblouir.

Wall or ground installation
Installation au mur ou au sol



Pixel 1 window

BODY MAT
AL, AISI316

DIF MAT
GLA



3
MacAdam

IP
65-67

IK
10

1 m

SEA SIDE
SUITABLE



CA 17 18

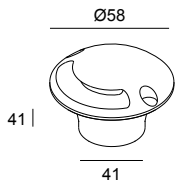
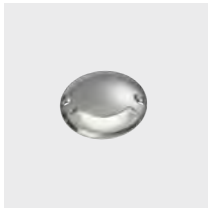

35

LED					
K	CRI	W	Real Lm	Code	
2700	80	3.4	9	CA 55-E001 - 17 - CK 18	
3000	80	3.4	10	CA 55-E001 - 17 - CL 18	
4000	80	3.4	10	CA 55-E001 - 17 - CM 18	

24VDC

Pixel 2 windows

BODY MAT
AL, AISI316

DIF MAT
GLA



3
MacAdam

IP
65-67

IK
10

1 m

SEA SIDE
SUITABLE



CA 17 18

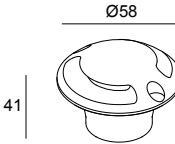
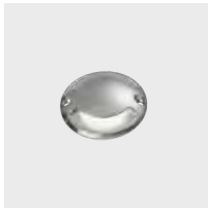

35

LED					
K	CRI	W	Real Lm	Code	
2700	80	3.4	20	CA 55-E002 - 17 - CK 18	
3000	80	3.4	21	CA 55-E002 - 17 - CL 18	
4000	80	3.4	22	CA 55-E002 - 17 - CM 18	

24VDC

Pixel 4 windows

BODY MAT
AL, AISI316

DIF MAT
GLA



3
MacAdam

IP
65-67

IK
10

1 m

SEA SIDE
SUITABLE



CA 17 18

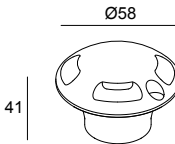
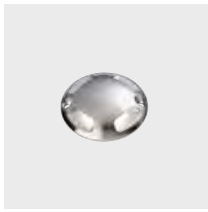



35

LED					
K	CRI	W	Real Lm	Code	
2700	80	3.4	15	CA 55-E003 - 17 - CK 18	
3000	80	3.4	15	CA 55-E003 - 17 - CL 18	
4000	80	3.4	16	CA 55-E003 - 17 - CM 18	

24VDC

Power supplies Sources d'alimentation

P. 985

	ON-OFF IP20	Max. 20W	71-B650-00-00		ON-OFF IP67	Max. 30W	71-B644-00-00 
		Max. 30W	71-B640-00-00			Max. 60W	71-B645-00-00
		Max. 100W	71-B641-00-00			Max. 100W	71-B646-00-00

Connective controllers Contrôleurs connectés

P. 969



Consult the available control systems / Consultez les systèmes de contrôle disponibles:

DALI2 / DALI2

Bluetooth wireless / Sans fil Bluetooth

DMX / DMX

Autonomous / Autonome

Fixing accessories Accessoires de fixation



Recess case
Boîtier d'encastrement

Included



Easy installation Facilité d'installation

The Xena collection features easily replaceable LED modules, 4 cable glands and a large space inside to add extra components, such as over-voltage protectors.

La collection Xena comprend des modules LED facilement remplaçables, 4 presse-étoupes et un grand espace intérieur qui permet l'ajout de composants supplémentaires, par exemple des parasurtenseurs.

Interior space for connections Espace intérieur pour les branchements



To facilitate installation, it has four cable glands that can be installed individually (two for cables of Ø6 to Ø11 and two for cables of Ø8 to Ø16) and a large space for connections inside the luminaire.

Pour faciliter l'installation, ce modèle est muni de 4 presse-étoupes qui peuvent être installés individuellement (2 pour les câbles de Ø6 à Ø11 et 2 pour les câbles de Ø8 à Ø16) et d'un grand espace pour les connexions à l'intérieur du luminaire.



14

34

DL

E3

J6

Z5

60



Xena LED

50000h
L80 B20

3
MacAdam

BODY MAT
AL, POLI

DIF MAT
PC

IP
66-67

IK
10



Z5* 14* 60* 34 J6* E3* DL*

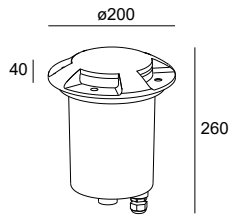
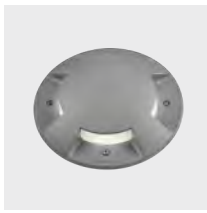

LED						
K	CRI	W Total	Real Lm	Code		
2700	80	5.7	70	55-E102	Z5 J6 E3 - DL - CK	ON-OFF 100-240V
					14 60 34	
3000	80	5.7	70	55-E102	Z5 J6 E3 - DL - CL	ON-OFF 100-240V
					14 60 34	
4000	80	5.7	74	55-E102	Z5 J6 E3 - DL - CM	ON-OFF 100-240V
					14 60 34	

Xena E27

BODY MAT
AL, POLI

DIF MAT
PC

IP
65-67

IK
10



Z5* 14* 60* 34 J6* E3* DL*

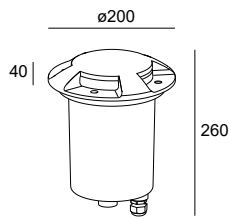
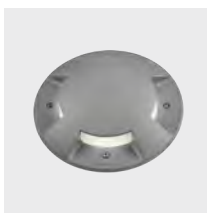

E27	
W	Code
Max. 15	Z5 J6 E3 55-9428 - DL - M3
	14 60 34

Fixing accessories Accessoires de fixation



Recess case
Boitier d'encastrement

Included

* Please contact our sales team for conditions and delivery times.
* Consultez notre équipe commerciale pour connaître les conditions et les délais de livraison.

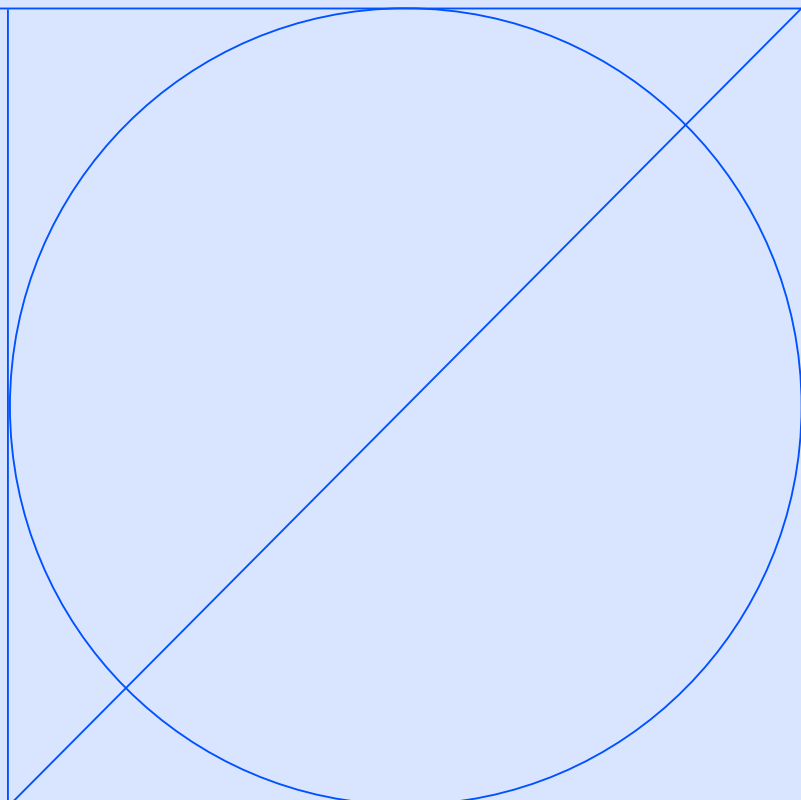

Surface uplights

Encastrés de surface

Path

686



Xena

690



Rexel

692

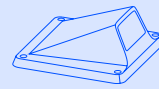

Soul

694



Path



Soft and low-level ground illumination Éclairage doux et rasant au sol

The Path collection offers indirect and infinite ambient lighting that accentuates the architectural elements of a space and acts as a guide in transit areas, creating gentle and balanced atmospheres without glare or excessive light.

La collection Path offre une éclairage ambiant indirect et infini qui contribue à mettre en valeur l'architecture de l'espace et sert de guide pour s'orienter dans les zones de passage. Cela crée des atmosphères douces et équilibrées, sans éblouissement ni excès de lumière.

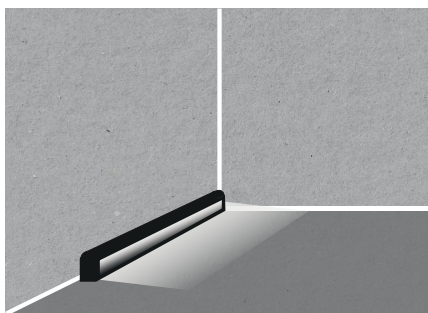

Installation options Types d'installation

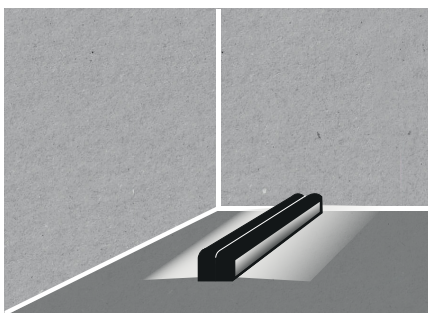

14



34



DL



E3



J6



Z5

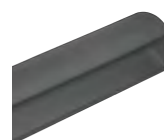

60





Path

BODY MAT AL	DIF MAT PMMA		50000h L80 B20	IP 66-67	IK 10	UGR <10	 0.15 m		SEA SIDE SUITABLE		
----------------	-----------------	--	-------------------	-------------	----------	------------	------------	--	----------------------	--	--

Z5* 14* 60* 34* J6* E3* DL* 54

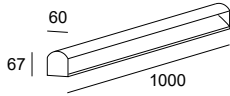

LED						24VDC	
K	CRI	W	Real Lm	Code			
3000	80	9.6	184	55-E034	Z5		
					J6		
					E3		
					DL	- CL	
					54		
4000	80	9.6	184	55-E034	Z5		
					J6		
					E3		
					DL	- CM	
					54		
RGB*		9.6	138	55-E071	Z5		
					J6		
					E3		
					DL	- 00	
					54		
					14		
					60		
					34		

(* The indicated flow corresponds to the temperature R + G + B.
 (*) Le flux indiqué correspond à la température R + G + B.
 Please contact our sales team for conditions and delivery times.
 Consultez notre équipe commerciale pour connaître les conditions et les délais de livraison.

Constant Voltage

Power supplies

P. 985

Sources d'alimentation



	ON-OFF IP20	Max.20W	71-B650-00-00		ON-OFF IP67	Max.30W	71-B644-00-00
		Max.30W	71-B640-00-00			Max.60W	71-B645-00-00
		Max.100W	71-B641-00-00			Max.100W	71-B646-00-00
		Max.150W	71-B642-00-00			Max.150W	71-B647-00-00
	DALI2 IP67	Max.60W	71-B652-00-00		DALI2 IP67	Max.60W	71-B655-00-00
		Max.150W	71-B652-00-00			Max.160W	71-B656-00-00

Connective controllers

P. 969

Contrôleurs connectés

Consult the available control systems / Consultez les systèmes de contrôle disponibles:
 DALI2 / DALI2
 Bluetooth wireless / Sans fil Bluetooth
 DMX / DMX
 Autonomous / Autonome

	Path	Path RGB
		

Connection accessories
Accessoires de connexion

	Cable with waterproof tongue and groove connectors (1 m) Câble avec connecteurs étanches mâle-femelle (1 m)	71-E034-00-00	-
	Cable with waterproof tongue and groove connectors (5 m) Câble avec connecteurs étanches mâle-femelle (5 m)	71-E004-00-00	-
	RGB cable with waterproof tongue and groove connectors (1 m) Câble RGB avec connecteurs étanches mâle-femelle (1 m)	-	71-E071-00-00
	RGB cable with waterproof tongue and groove connectors (5 m) Câble RGB avec connecteurs étanches mâle-femelle (5 m)	-	71-E005-00-00
	Waterproof connectors Connecteurs étanches	Included	Included
	IP67 connector (1 input + 1 output) Ø 5.5–7.5 mm, 3 poles Connecteur IP67 (1 entrée + 1 sortie) Ø 5,5 - 7,5 mm, 3 pôles	71-E510-00-00	-
	IP67 connector (1 input + 2 outputs) Ø 5.5–7.5 mm, 3 poles Connecteur IP67 (1 entrée + 2 sorties) Ø 5,5 - 7,5 mm, 3 pôles	71-E511-00-00	-
	IP68 connector (1 input + 1 output) Ø 5.5–11.5 mm, 4 poles Connecteur IP68 (1 entrée + 1 sortie) Ø 5,5 - 11,5 mm, 4 pôles	71-E512-00-00	71-E512-00-00
	IP68 connector (1 input + 2 outputs) Ø 5.5–11.5 mm, 3 poles Connecteur IP68 (1 entrée + 2 sorties) Ø 5,5 - 11,5 mm, 3 pôles	71-E513-00-00	-
	IP68 anti-condensation connector (1 input + 1 output) Ø 5.5–12 mm, 4 poles Connecteur anticondensation IP68 (1 entrée + 1 sortie) Ø 5,5 - 12 mm, 4 pôles	71-E112-00-00	71-E112-00-00
	IP68 anti-condensation connector (1 input + 3 outputs) Ø 5.5–12 mm, 4 poles Connecteur anticondensation IP68 (1 entrée + 3 sorties) Ø 5,5 - 12 mm, 4 pôles	71-E122-00-00	71-E122-00-00
	Waterproof cable Câble imperméable	Included	Included

Joint accessories
Accessoires de raccord

	Plates for interlinked installation Plaques pour installation enchainée	Included	Included
-------------------------------------------------------------------------------------	----------------------------------------------------------------------------	----------	----------

Xena Surface



Versatile and easy to install Polyvalente et facile à installer

The Xena Surface collection offers easy installation as it does not require any recessing or drainage. With a built-in driver in the head, it does not require remote equipment and offers a choice of two colour temperatures as it includes a 3000K filter.

Xena Surface est une collection facile à installer, car elle ne nécessite ni encastrément ni drainage. Grâce au driver installé dans la tête, ces modèles ne nécessitent pas d'appareillage à distance et permettent de choisir entre deux températures de couleur, car ils comprennent un filtre de 3 000 K.



Xena Surface 1 Side

BODY MAT	DIF MAT
AL	PC



50000h
L80 B20

3
MacAdam

IP
66

IK
10

LOW
FLICKER

KG
800 Kg



SEA SIDE
SUITABLE



Z5* 14* 60* 34 J6* E3* DL*

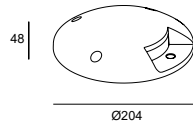

LED

K	CRI	W Total	Real Lm	Code	
					Z5 J6 E3
4000	80	2	46	55-9945	- DL - CM ON-OFF 100-240VAC
					14 60 34

Xena Surface 2 Sides

BODY MAT	DIF MAT
AL	PC



50000h
L80 B20

3
MacAdam

IP
66

IK
10

LOW
FLICKER

KG
800 Kg



SEA SIDE
SUITABLE



Z5* 14* 60* 34 J6* E3* DL*

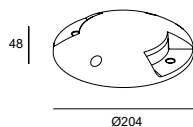

LED

K	CRI	W Total	Real Lm	Code	
					Z5 J6 E3
4000	80	4.5	78	55-9946	- DL - CM ON-OFF 100-240VAC
					14 60 34

Xena Surface 4 Sides

BODY MAT	DIF MAT
AL	PC



50000h
L80 B20

3
MacAdam

IP
65

IK
10

KG
800 Kg



SEA SIDE
SUITABLE



Z5* 14* 60* 34 J6* E3* DL*

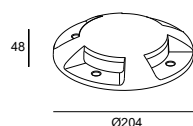
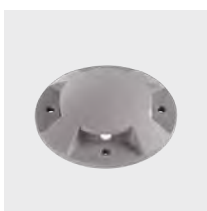

LED

K	CRI	W Total	Real Lm	Code	
					Z5 J6 E3
4000	80	7.2	163	55-9947	- DL - CM ON-OFF 100-240V
					14 60 34

Lens accessories Accessoires optiques



3000K filter
Filtre 3 000 K

Included

* Please contact our sales team for conditions and delivery times.
* Consultez notre équipe commerciale pour connaître les conditions et les délais de livraison.

Rexel

Designed by Francesc Vilaró

Compact and functional Compact et fonctionnel

Rexel is an excellent alternative to traditional spotlights in spaces requiring open views to showcase the landscape or architecture.
Rexel remplace les projecteurs traditionnels dans les espaces qui nécessitent des vues dégagées pour mettre en valeur le paysage ou l'architecture.



Manual control and
adjustment of the swivel
head to direct the light
Contrôle et réglage manuels
de la tête basculante pour
diriger la lumière

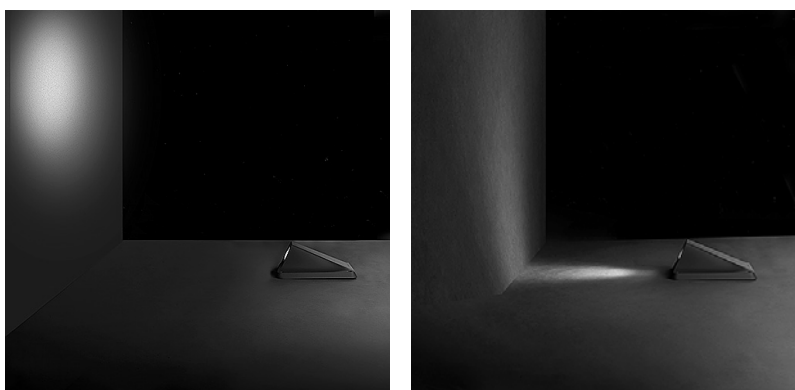

**Rexel
2 LEDS**

BODY MAT
AL

DIF MAT
PMMA



50000h
L80 B20

3
MacAdam

IP
66-67

IK
10

LOW
FLICKER

BREEAM

SEA SIDE SUITABLE

0° a 15°

LED

DRIVER

Z5

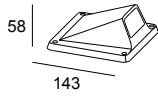

LED						
K	CRI	W Total	Real Lm	Code		
3000	80	3.4	187	55-9883 - Z5 - CL	ON-OFF 100-240VAC	

**Rexel
4 LEDS**

BODY MAT
AL

DIF MAT
PMMA



50000h
L80 B20

3
MacAdam

IP
66-67

IK
09

LOW
FLICKER

BREEAM

SEA SIDE SUITABLE

0° a 15°

LED

DRIVER

Z5

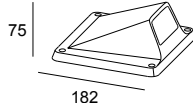

LED						
K	CRI	W Total	Real Lm	Code		
3000	80	6.1	412	55-9741 - Z5 - CL	ON-OFF 100-240V	

Soul

Designed by Benedito Design



+ Soul



Special design for no recessing and drainage Design spécial qui évite l'encastrement et le drainage

Soul is a designer luminaire offering advanced technical features and easy installation. Despite being ultra-flat, the equipment is included inside, so there is no recessing or drainage needed. This is a versatile collection with excellent architectural integration.

Soul est un luminaire design aux prestations techniques élevées et facile à installer, car son appareillage est installé à l'intérieur malgré sa silhouette ultraplate, ce qui permet d'éviter l'encastrement ou le drainage. C'est une collection polyvalente à forte intégration architecturale.



It can be installed as a ceiling light.
Il peut être installé sous forme de plafonnier.





Lenses Systèmes optiques

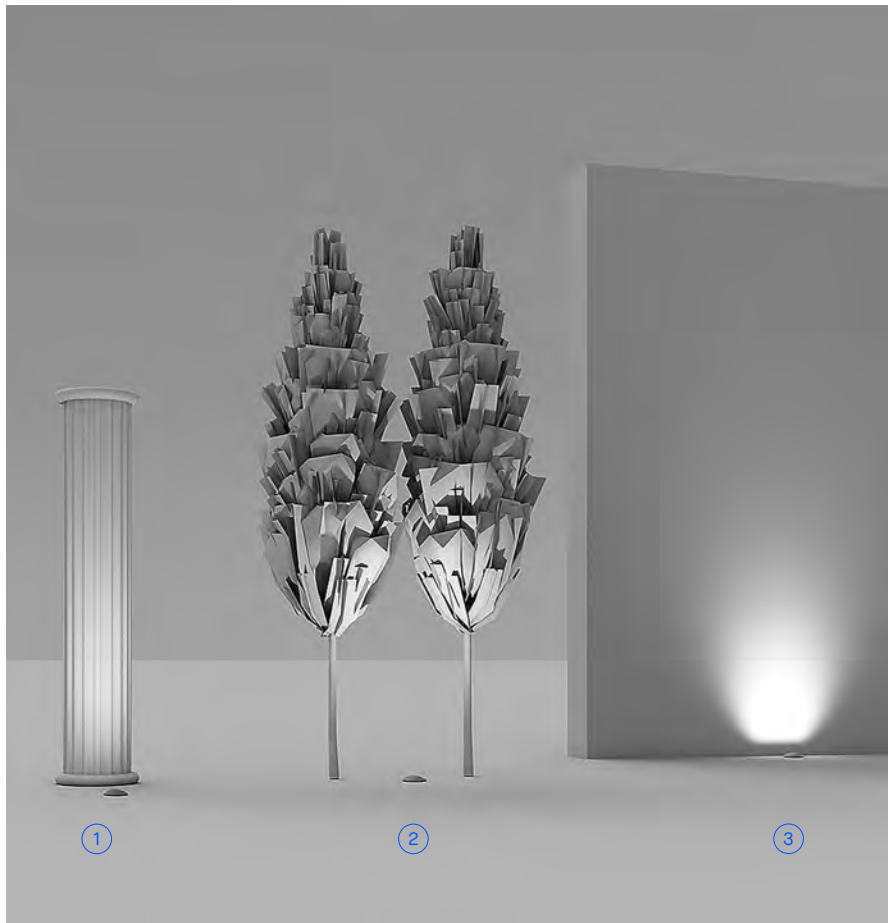

① ②
Symmetrical
Symétriques

③
Asymmetrical by means of Jumbecker filter
Asymétriques avec filtre Jumbecker

Soul 195mm

BODY MAT	DIF MAT	50000h	3	IP	IK	BREEAM	1000 Kg	SEA SIDE SUITABLE	LED
AL	GLA	L80 B20	MacAdam	66-67	10				

Code exemple / Exemple d'élaboration d'une référence: **AL11-P6V9S2OUZ5**

Model	W	K	CRI	Optics	Real Lm	Source	Finishes	
AL11 - 	P6V9	7	2700	90	S2 16°	560-638	OU ON-OFF 100-277V	Z5
	P6W9	7	3000	90	M3 38°	560-638	BB 6W 9V/max.700mA	
	P6X9	7	4000	90	F1 48°	609-693		

Soul 260mm

BODY MAT	DIF MAT	50000h	3	IP	IK	BREEAM	1000 Kg	SEA SIDE SUITABLE	LED
AL	GLA	L80 B20	MacAdam	66-67	10				

Code exemple / Exemple d'élaboration d'une référence: **AL12-P6V9S2OUZ5**

Model	W	K	CRI	Optics	Real Lm	Source	Finishes	
AL12 - 	18V9	20	2700	90	S2 16°	1680-1914	OU ON-OFF 100-277V	Z5
	18W9	20	3000	90	M3 38°	1680-1914	BB 6W 9V/max.700mA	
	18X9	20	4000	90	F1 48°	1826-2080		











Soul 195mm

Soul 260mm



Drivers
Driver

P. 984

	ON-OFF IP20	71-B232-00-00 	71-6658-00-00 
		71-3542-00-00  Min.1 - Max.8	-
	ON-OFF IP67	71-E015-00-00  Min.2 - Max.3	71-E015-00-00 
	ON-OFF IP68	71-E014-00-00 	-
	DALI2 IP20	71-A192-00-00 Min.2 - Max.4	71-A192-00-00
	DALI2 IP68	71-E086-00-00 Min.2 - Max.5	71-E080-00-00

Lens accessories
Accessoires optiques

	Wall washer diffusor 9° x 53° Diffuseur alèche-mur 9° x 53°	71-E200-00-00	71-E207-00-00
-------------------------------------------------------------------------------------	----------------------------------------------------------------------	----------------------	----------------------

Connective controllers
Contrôleurs connectés

P. 969

	Consult the available control systems / Consultez les systèmes de contrôle disponibles: DALI2 / DALI2 Bluetooth wireless / Sans fil Bluetooth Autonomous / Autonome
-------------------------------------------------------------------------------------	-------------------------------------------------------------------------------------------------------------------------------------------------------------------------------------

Bollards / Lampost Balises / Réverbères

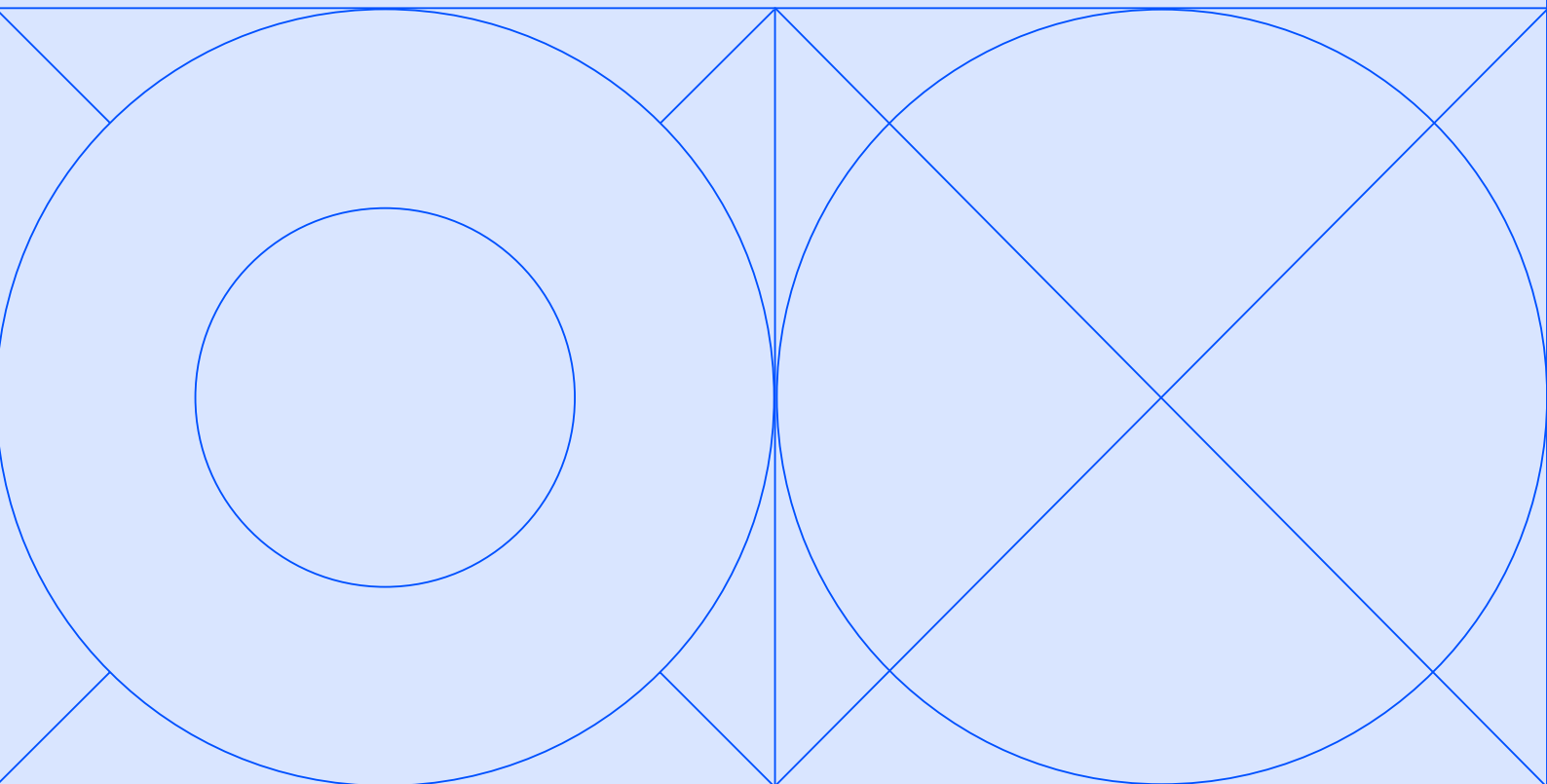

Ele
702



Modis
706

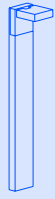

Helion
714

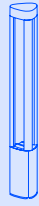

Orbit
718



Lyon
726



Juncus
730



Invisible
734



Max
738



Eko
744

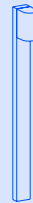

Rek
747

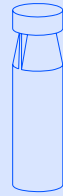

Newton
754



Dan
760



Row
764



Simenti
766

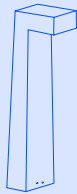

Diago
768



Cubik
769



Priap
772



Nott
773



Grid
774

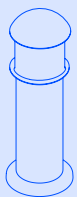

Citizen
775



Proud
776

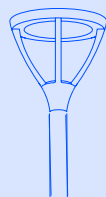

ZigZag
778



Pro-base System



Pro-base is a base concealed inside the bollards. Exclusive to LedsC4, it is designed to maximise stability and robustness, guaranteeing an extended useful life and alignment of all installed bollards. Exclusif à LedsC4 et conçu pour optimiser la stabilité et la robustesse, Pro-base est un socle dissimulé dans les bornes qui assure une plus longue durée de vie et l'alignement de toutes les bornes installées.

Bollards with Pro-base system Bornes avec système Pro-base

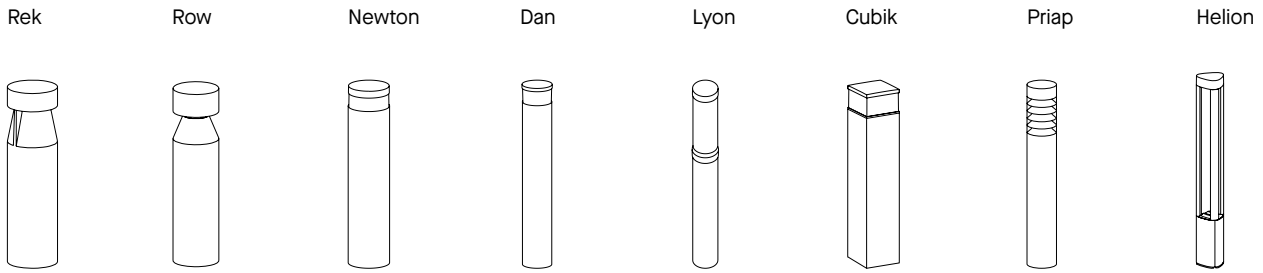

Perfect levelling Nivellement parfait

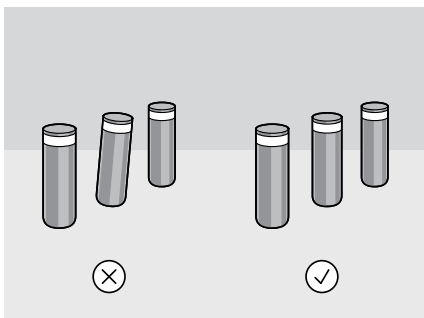

Maximum robustness Maximum de robustesse

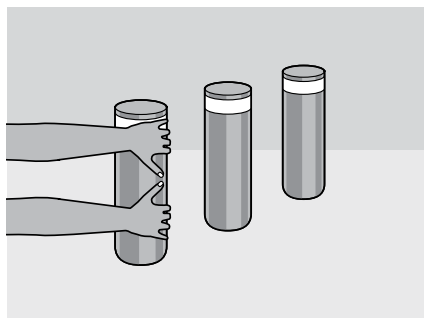



① **Base**
Socle

Aluminium base with extra thickness to avoid weak points and with cataphoresis anti-corrosion treatment.
Socle en aluminium d'une épaisseur supérieure pour éviter les points faibles et avec traitement anticorrosion par cataphorèse.

② **Levelling screws**
Vis de nivellement

The system enables the bollard to be levelled to achieve perfect alignment on uneven ground or terrain with a slope of up to 5°. This is achieved using the three levelling screws included in the system.

Le système permet de niveler la borne pour obtenir un alignement parfait sur un terrain irrégulier ou présentant une pente allant jusqu'à 5°, grâce aux trois vis de nivellement fournies.

③ **Protective layer**
Film protecteur

Includes a technopolymer layer to insulate the base from direct contact with the ground and prevent the aluminium being scratched during installation.

Comprend un film en technopolymère qui permet d'isoler le socle du contact direct avec le sol, évitant ainsi toute éraflure de l'aluminium lors de l'installation.

④ **Fixing bolts**
Boulons de fixation

Optional bolts recommended by LedsC4 for increased robustness.
Boulons en option recommandés par LedsC4 pour plus de robustesse.

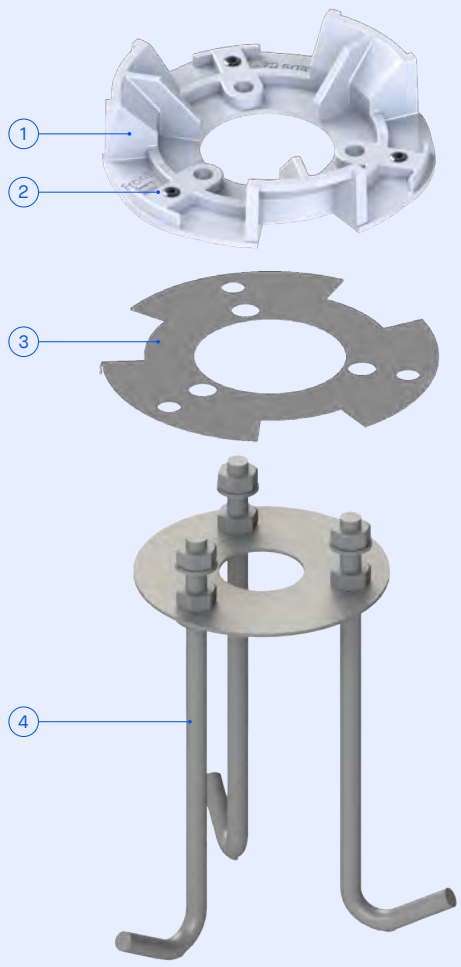

Ele

Designed by Luca Turrini



+ Ele



Functionality and design to illuminate challenging spaces Fonctionnalité et design pour éclairer des espaces exigeants

The Ele collection, consisting of bollards and lampposts, features an elegant design aimed at delivering maximum lighting comfort and energy efficiency while eliminating light pollution. To achieve this, it incorporates asymmetrical lenses and customisable colour temperatures to suit various projects. It serves as an excellent choice for both timeless and architectural spaces, including museums, universities and large residential areas.

Arborant un design élégant et constituée de bornes et de lampadaires, la collection Ele vise à obtenir un maximum de confort lumineux et d'efficacité énergétique sans pollution lumineuse. Pour cela, elle dispose d'optiques asymétriques et de températures de couleur qui s'adaptent au mieux aux projets. C'est une option idéale pour les espaces intemporels et architecturaux tels que les musées, les universités et les vastes espaces résidentiels.

900 mm

2400 mm



14

34

DL

E3

J6

Z5

60





Available in 2200 K, a temperature that is more eco-friendly for the local plant and animal life.
 Disponible en 2200K, température plus respectueuse de la faune et la flore environnantes.

2200K



2700K



3000K



Easy maintenance in case of breakage
 Entretien facile en cas de rupture

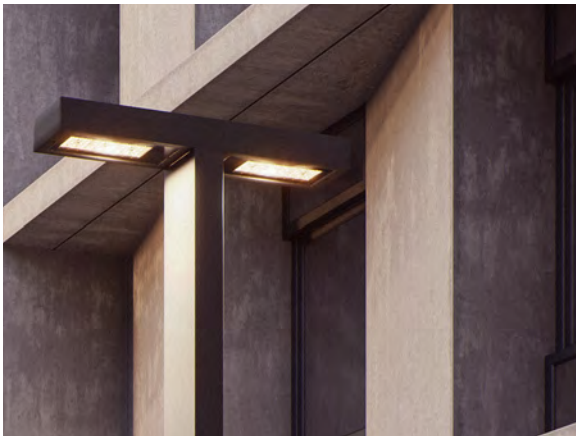

Perfect for pathways
 Parfait pour les zones de passage

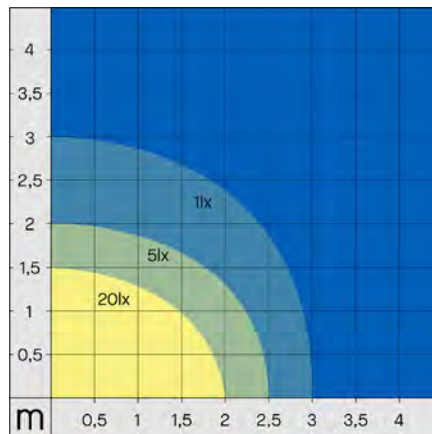

55-E014

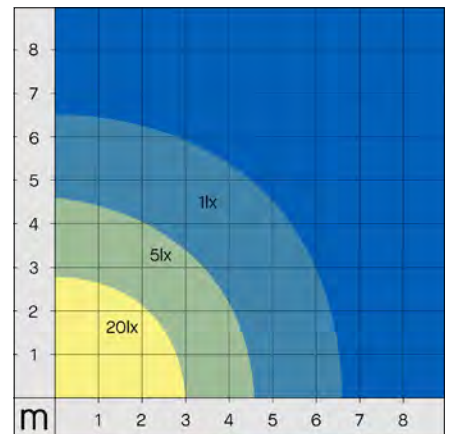

55-E105

Ele Bollard

IK	IP
10	66



BODY MAT	DIF MAT
AL	GLA

3
MacAdam

50000h
L80 B20

BREEAM



Z5 *14 *60 *34 *J6 *E3 *DL

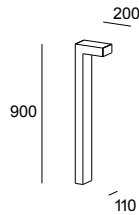

K	CRI	W	Real Lm	Code
				Z5
				J6
2200	80	10.3	871	E3 CW
2700	80	10.3	968	55-E104 - DL - CK ON-OFF 100-240V
3000	80	10.3	968	14 CL
				60
				34

Ele Lampost 1 Head

IK	IP
10	66



BODY MAT	DIF MAT
AL	GLA

3
MacAdam

50000h
L80 B20

BREEAM



Z5 *14 *60 *34 *J6 *E3 *DL

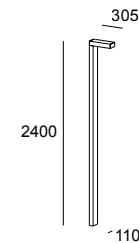

K	CRI	W	Real Lm	Code
				Z5
				J6
2200	80	26	2456	E3 CW
2700	80	26	2729	55-E105 - DL - CK DALI2 100-240V
3000	80	26	2729	14 CL
				60
				34

Ele Lampost 2 Heads

IK	IP
10	66



BODY MAT	DIF MAT
AL	GLA

3
MacAdam

50000h
L80 B20

BREEAM



Z5 *14 *60 *34 *J6 *E3 *DL

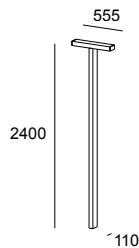

K	CRI	W	Real Lm	Code
				Z5
				J6
2200	80	49	4913	E3 CW
2700	80	49	5458	55-E106 - DL - CK DALI2 100-240V
3000	80	49	5458	14 CL
				60
				34

Modis

Designed by Luca Turrini



+ Modis

Wall
P. 782

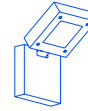

Ceiling
P. 862



Spotlight
P. 553



Freedom of movement Liberté de mouvement

Modis' double ball joint design allows the head of bollards and lampposts to be moved in any direction, thus achieving a comfortable, uniform, directed light that accompanies users all the way along.

La conception à double rotule de Modis permet de déplacer la tête des bornes et des lampadaires d'extérieur dans n'importe quelle direction, obtenant ainsi un éclairage confortable, uniforme et directionnel qui vous accompagne jusqu'au bout

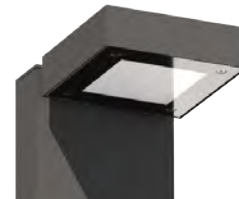

Opal



Optics

500 mm

1000 mm

1 Head 2300 mm

2 Heads 2300 mm



14

34

DL

E3

J6

Z5

60





Available in 2200 K, a temperature that is more eco-friendly for the local plant and animal life.
 Disponible en 2200K, température plus respectueuse de la faune et la flore environnantes.

2200K



2700K



3000K



4000K

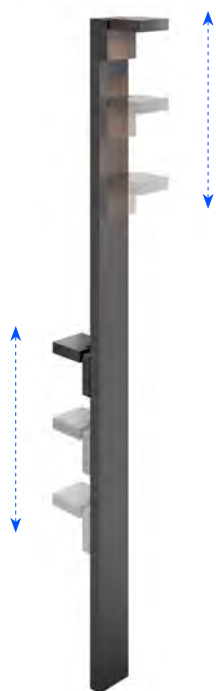

Independently select the height of each head
 Permet de choisir la hauteur de chaque tête de façon indépendante

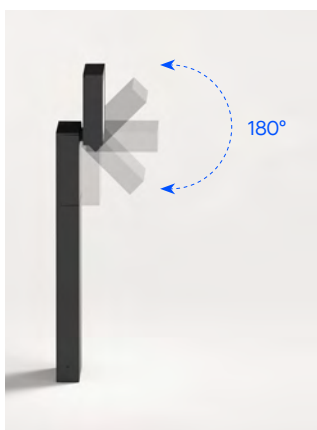



Modis Bollard

BODY MAT	DIF MAT		50000h	3
AL	GLA		L80 B20	MacAdam

Modis Bollard Opal 500mm

IP	IK	BREEAM	SWITCH CCT		SEA SIDE SUITABLE				
66	10		2700-3200-4000			180°	350°		

Z5 14* 60* 34* J6* E3* DL*

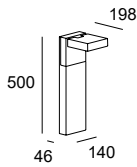

LED						
K	CRI	W Total	Real Lm	Code		
					Z5	
					J6	
2700-3200-4000	80	13.2	744	55-E022	E3	OU ON-OFF 100-277V
					DL	DU DALI-2 100-277V
					14	XB CASAMBI 220-240V
					60	
					34	

The indicated flux corresponds to the core temperature.
Le flux indiqué correspond à la température centrale.

Modis Bollard Opal 1000mm

IP	IK	BREEAM	SWITCH CCT		SEA SIDE SUITABLE				
66	10		2700-3200-4000			180°	350°		

Z5 14* 60* 34* J6* E3* DL*

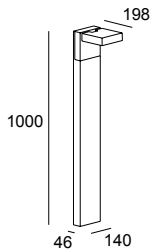

LED						
K	CRI	W Total	Real Lm	Code		
					Z5	
					J6	
2700-3200-4000	80	13.2	744	55-E023	E3	OU ON-OFF 100-277V
					DL	DU DALI-2 100-277V
					14	XB CASAMBI 220-240V
					60	
					34	

The indicated flux corresponds to the core temperature.
Le flux indiqué correspond à la température centrale.

Modis Bollard Optics 500mm



Code example / Exemple d'élaboration d'une référence: **AS14-18V9S30UZ5**

Model	W	K	CRI	Real Lm	Optics	Source	Finishes	
AS14 - IP66 ϕ 350° \Leftarrow 180° 	18P8	18.3	2200	80	932-1062	S3 16°	OU ON-OFF 100-277V	Z5
	18V9	18.3	2700	90	1680-1914	M3 38°	DS DALI-2/PUSH 220-240V	14*
	18W9	18.3	3000	90	1680-1914	F1 48°	XB CASAMBI 220-240V	60*
	18X9	18.3	4000	90	1826-2080			34*
							J6*	
							E3*	
							DL*	

Modis Bollard Optics 1000mm



Code example / Exemple d'élaboration d'une référence: **AS15-18V9S30UZ5**

Model	W	K	CRI	Real Lm	Optics	Source	Finishes	
AS15 - 	18P8	18.3	2200	80	932-1062	S3 16°	OU ON-OFF 100-277V	Z5
	18V9	18.3	2700	90	1680-1914	M3 38°	DS DALI-2/PUSH 220-240V	14*
	18W9	18.3	3000	90	1680-1914	F1 48°	XB CASAMBI 220-240V	60*
	18X9	18.3	4000	90	1826-2080			34*
							J6*	
							E3*	
							DL*	

Lens accessories Accessoires optiques



Visor
Visière

Z5	71-E234-Z5-00	14	71-E234-14-00
J6	71-E234-J6-00	60	71-E234-60-00
E3	71-E234-E3-00	34	71-E234-34-00
DL	71-E234-DL-00		

Fixing accessories Accessoires de fixation



Fixing bolts
Boulons de fixation

71-E363-48-48

* Please contact our sales team for conditions and delivery times.
* Consultez notre équipe commerciale pour connaître les conditions et les délais de livraison.

Modis Lampost

BODY MAT	DIF MAT		50000h	3
AL	GLA		L80 B20	MacAdam

Modis Lampost Opal 1 Head 2300mm

IP	IK	BREEAM	SWITCH CCT		SEA SIDE SUITABLE				
66	10		2700-3200-4000			350°	90°		

Z5 14* 60* 34* J6* E3* DL*

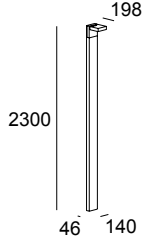

LED						
K	CRI	W Total	Real Lm	Code		
2700-3200-4000	80	13.2	744	55-E024	Z5	
					J6	
					E3	OU ON-OFF 100-277V
					DL	DU DALI-2 100-277V
					14	XB CASAMBI 220-240V
					60	
					34	

The indicated flux corresponds to the core temperature.
Le flux indiqué correspond à la température centrale.

Modis Lampost Optics 1 Head 2300mm

IP	IK	UGR	BREEAM		SEA SIDE SUITABLE				
66	10	<10				350°	180°		

Code example / Exemple d'élaboration d'une référence: **AS16-18V9S30UZ5**

Model		W	K	CRI	Real Lm	Optics	Source	Finishes
AS16 - 	18P8	18.3	2200	80	932-1062	S3 16°	OU ON-OFF 100-277V	Z5
	18V9	18.3	2700	90	1680-1914	M3 38°	DS DALI-2/PUSH 220-240V	14*
	18W9	18.3	3000	90	1680-1914	F1 48°	XB CASAMBI 220-240V	60*
	18X9	18.3	4000	90	1826-2080			34*
								J6*
								E3*
								DL*

**Modis Lampost
2 Heads
2300mm**

Z5 14* 60* 34* J6* E3* DL*

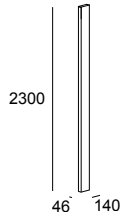
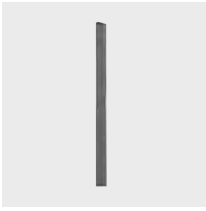

Code	
Z5	
J6	
E3	
71-E608 - DL - 00	
14	
60	
34	

The indicated flux corresponds to the core temperature.
Le flux indiqué correspond à la température centrale.

**Modis Opal
Head**

IP	IK	SWITCH CCT		SEA SIDE SUITABLE			LED	DRIVER
66	10	2700-3200-4000			180°	350°		

Z5 14* 60* 34* J6* E3* DL*

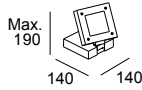

LED				Code	
K	CRI	W Total	Real Lm		
				Z5	
				J6	
				E3	OU ON-OFF 100-277V
2700-3200-4000	80	13.2	744	05-E062 - DL - DU	DALI-2 100-277V
				14	XB CASAMBI 220-240V
				60	
				34	

The indicated flux corresponds to the core temperature.
Le flux indiqué correspond à la température centrale.

**Modis Optics
Head**

IP	IK	BREEM		SEA SIDE SUITABLE			LED	DRIVER
66	10				350°	180°		

Code example / Exemple d'élaboration d'une référence: **AS11-18V9S30UZ5**

Model		W	K	CRI	Real Lm	Optics	Source	Finishes
AS11 - Single ↻350° ↻180° Max. 190 140 140		18P8	18.3	2200	80	932-1062	S3 16°	OU ON-OFF 220-240V
		18V9	18.3	2700	90	1680-1914	M3 38°	DS DALI-2/PUSH 220-240V
		18W9	18.3	3000	90	1680-1914	F1 48°	XB CASAMBI 220-240V
		18X9	18.3	4000	90	1826-2080		
								Z5 14* 60* 34* J6* E3* DL*

**Lens accessories
Accessoires optiques**



Visor
Visière

Z5	71-E234-Z5-00	14	71-E234-14-00
J6	71-E234-J6-00	60	71-E234-60-00
E3	71-E234-E3-00	34	71-E234-34-00
DL	71-E234-DL-00		

* Please contact our sales team for conditions and delivery times.
* Consultez notre équipe commerciale pour connaître les conditions et les délais de livraison.

Helion

Designed by LedsC4 Architectural



+ Helion

More than lighting Plus qu'un éclairage

Stylised and elegant, Helion's parcelled design with windows allows it to cast a delightful play of light and shadow on the floor, allowing it to become more than a simple Lamppost or bollard and making it a key feature that brings harmony to its surroundings.

Stylée et élégante, la conception ajourée d'Helion lui permet de projeter au sol un intéressant jeu d'ombre et de lumière. Ce modèle va ainsi au-delà de sa fonction de lampadaire ou de borne pour devenir un élément clé dans l'harmonisation de l'environnement.



800 mm

2300 mm







General and decorative light at the same time
Éclairage à la fois général et décoratif



CCT Switch / Interrupteur CCT

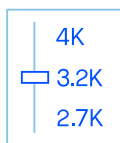

Helion Bollard

BODY MAT
AL

DIF MAT
PC



3
MacAdam

IP
66

IK
10

BREEAM

SWITCH CCT
2700-3200-4000



SEA SIDE
SUITABLE

PRO-BASE

LED

DRIVER

Z5

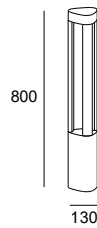

LED

K	CRI	W Total	Real Lm	Code	
2700-3200-4000	80	10.7	701	55-E075 55-E100	ON-OFF 100-240V DALI-2 20-240V

The indicated flux corresponds to the core temperature.
Le flux indiqué correspond à la température centrale.

Helion Lampost

BODY MAT
AL

DIF MAT
PC



3
MacAdam

IP
66

IK
10

BREEAM

SWITCH CCT
2700-3200-4000



SEA SIDE
SUITABLE

LED

DRIVER

Z5

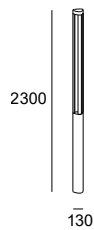

LED

K	CRI	W Total	Real Lm	Code	
2700-3200-4000	80	22	1323	55-E077 55-E103	ON-OFF 100-240V DALI-2 120-240V

The indicated flux corresponds to the core temperature.
Le flux indiqué correspond à la température centrale.

Fixing accessories Accessoires de fixation



Fixing bolts
Boulons de fixation

71-E012-48-48

Connective controllers Contrôleurs connectés

P. 969



Consult the available control systems / Consultez les systèmes de contrôle disponibles:
DALI2 / DALI2
Bluetooth wireless / Sans fil Bluetooth
Autonomous / Autonome

Orbit

Designed by Luca Turrini

Chillout
P. 884



Illuminating accompanied Éclairage d'accompagnement

Orbit is the ideal choice for creating warm environments in areas where lighting is the key to success when it comes to connecting with customers and users. Featuring soft shapes and various choices of finishes and light beam directions, Orbit's mere presence grants a distinct touch of quality to the space it inhabits. Orbit est le choix idéal pour créer des atmosphères chaleureuses là où l'éclairage est la clé du succès dans la connexion avec clients et utilisateurs. Avec ses formes douces et différentes options de finitions et de directions du faisceau lumineux, la présence d'Orbit confère un plus de qualité à l'espace qu'il habite.

2300 mm

1200 mm

900 mm

500 mm

335 mm

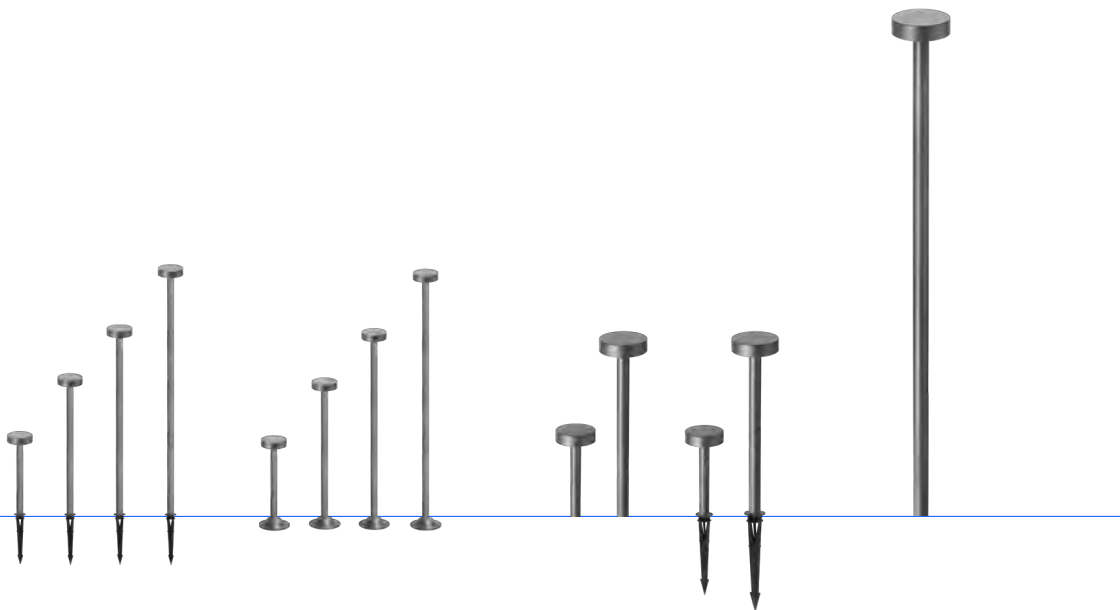

14

34

DL

E3

J6

Z5

60







Light options on the top of the head: Signage point, zero light pollution and soft upward light.

Options d'éclairage sur la partie supérieure de la tête : point de signalisation, aucune pollution lumineuse et lumière douce vers le haut.

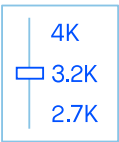

Built-in CCT switch that allows you to change the colour temperature according to the needs of the space.

Switch (interrupteur) CCT intégré qui permet de modifier la température de couleur en fonction des besoins de l'espace.

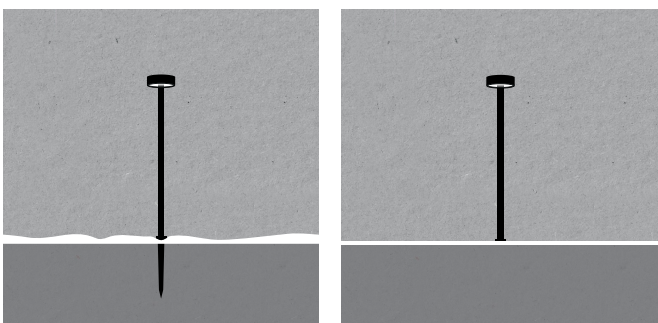

BODY MAT	DIF MAT	50000h	3
AL	PC	L80 B20	MacAdam

Orbit Bollard Covered Ø202mm 500mm

IP	IK		BREEAM	SWITCH CCT	SEA SIDE SUITABLE	LED	DRIVER
66	10			2700-3200-4000			

Z5 14* 60* 34* J6* E3* DL*

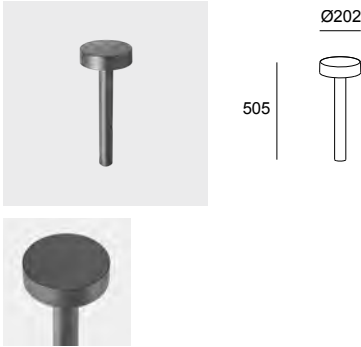

LED						
K	CRI	W Total	Real Lm	Code		
2700-3200-4000	80	11.5	761	55-E084 - DL - EH	Z5	ON-OFF 100-240V
					J6	
					E3	
					14	
					60	
					34	

The indicated flux corresponds to the core temperature.
Le flux indiqué correspond à la température centrale.

Orbit Bollard Small Hole Cover Ø202mm 500mm

IP	IK		BREEAM	SWITCH CCT	SEA SIDE SUITABLE	LED	DRIVER
66	10			2700-3200-4000			

Z5 14* 60* 34* J6* E3* DL*

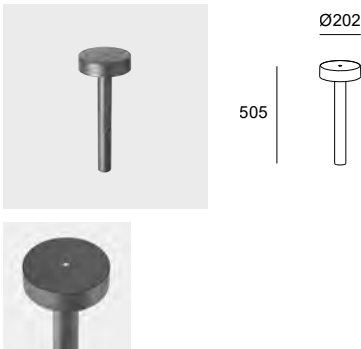

LED						
K	CRI	W Total	Real Lm	Code		
2700-3200-4000	80	11.5	764	55-E085 - DL - EH	Z5	ON-OFF 100-240V
					J6	
					E3	
					14	
					60	
					34	

The indicated flux corresponds to the core temperature.
Le flux indiqué correspond à la température centrale.

Orbit Bollard Big Hole Cover Ø202mm 500mm

IP	IK		BREEAM	SWITCH CCT	SEA SIDE SUITABLE	LED	DRIVER
66	10			2700-3200-4000			

Z5 14* 60* 34* J6* E3* DL*

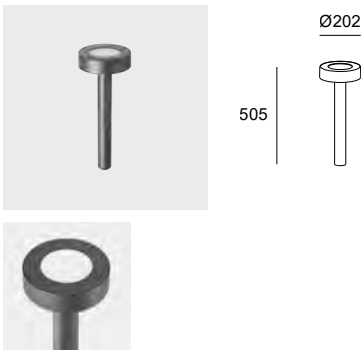

LED						
K	CRI	W Total	Real Lm	Code		
2700-3200-4000	80	11.5	858	55-E086 - DL - EH	Z5	ON-OFF 100-240V
					J6	
					E3	
					14	
					60	
					34	

The indicated flux corresponds to the core temperature.
Le flux indiqué correspond à la température centrale.

Fixing accessories Accessoires de fixation



302mm spiked post
Piquet de 302 mm

71-9998-05-05

* Please contact our sales team for conditions and delivery times.
* Consultez notre équipe commerciale pour connaître les conditions et les délais de livraison.

Orbit Bollard Cover
Ø202mm
900mm

IP
66

IK
10



SWITCH CCT
2700-3200-4000



Z5 14* 60* 34* J6* E3* DL*

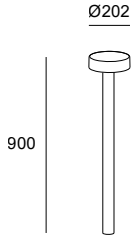

LED						
K	CRI	W Total	Real Lm	Code		
2700-3200-4000	80	11.5	761	55-E089	Z5	ON-OFF 100-240V
					J6	
					E3	
					DL - EH	
					14	
60						
34						

The indicated flux corresponds to the core temperature.
 Le flux indiqué correspond à la température centrale.

Orbit Bollard Small Hole Cover
Ø202mm
900mm

IP
66

IK
10



SWITCH CCT
2700-3200-4000



Z5 14* 60* 34* J6* E3* DL*

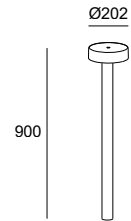

LED						
K	CRI	W Total	Real Lm	Code		
2700-3200-4000	80	11.5	764	55-E090	Z5	ON-OFF 100-240V
					J6	
					E3	
					DL - EH	
					14	
60						
34						

The indicated flux corresponds to the core temperature.
 Le flux indiqué correspond à la température centrale.

Orbit Bollard Big Hole Cover
Ø202mm
900mm

IP
66

IK
10



SWITCH CCT
2700-3200-4000



Z5 14* 60* 34* J6* E3* DL*

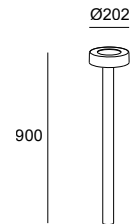

LED (3000K)						
K	CRI	W Total	Real Lm	Code		
2700-3200-4000	80	11.5	858	55-E091	Z5	ON-OFF 100-240V
					J6	
					E3	
					DL - EH	
					14	
60						
34						

The indicated flux corresponds to the core temperature.
 Le flux indiqué correspond à la température centrale.

Fixing accessories
Accessoires de fixation



302mm spiked post
 Piquet de 302 mm

71-9998-05-05

Orbit Bollard Covered Ø116mm

IP	IK		BREEAM	SWITCH CCT	SEA SIDE	LED	DRIVER
66	10			2700-3200-4000	SUITABLE		

Z5 14* 60* 34* J6* E3* DL*

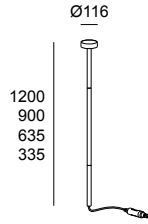
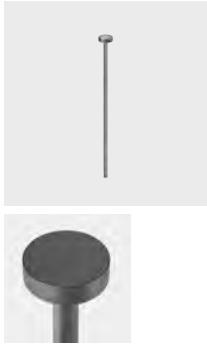

LED						
K	CRI	W Total	Real Lm	Code		
2700-3000-4000	80	5.3	313	10-E023 - DL - EH	Z5	ON-OFF 100-240V
					J6	
					E3	
					14	
					60	
					34	

The indicated flux corresponds to the core temperature.
Le flux indiqué correspond à la température centrale.

Orbit Bollard Small Hole Cover Ø116mm

IP	IK		BREEAM	SWITCH CCT	SEA SIDE	LED	DRIVER
66	10			2700-3200-4000	SUITABLE		

Z5 14* 60* 34* J6* E3* DL*

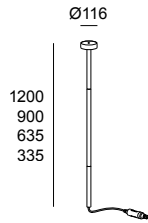
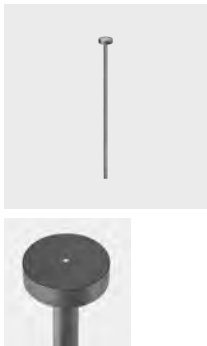

LED						
K	CRI	W Total	Real Lm	Code		
2700-3000-4000	80	5.3	314	10-E024 - DL - EH	Z5	ON-OFF 100-240V
					J6	
					E3	
					14	
					60	
					34	

The indicated flux corresponds to the core temperature.
Le flux indiqué correspond à la température centrale.

Orbit Bollard Big Hole Cover Ø116mm

IP	IK		BREEAM	SWITCH CCT	SEA SIDE	LED	DRIVER
66	10			2700-3200-4000	SUITABLE		

Z5 14* 60* 34* J6* E3* DL*

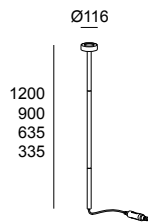
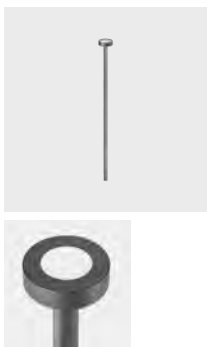

LED						
K	CRI	W Total	Real Lm	Code		
2700-3000-4000	80	5.3	353	10-E025 - DL - EH	Z5	ON-OFF 100-240V
					J6	
					E3	
					14	
					60	
					34	

The indicated flux corresponds to the core temperature.
Le flux indiqué correspond à la température centrale.

Required fixing accessories Accessoires de fixation nécessaires



Fixing base
Base de fixation

Z5 **71-E636-Z5-00** 14 * **71-E636-14-00**

J6 * **71-E636-J6-00** 60 * **71-E636-60-00**

E3 * **71-E636-E3-00** 34 * **71-E636-34-00**

DL * **71-E636-DL-00**



235mm spiked post
Piquet de 235 mm

71-9997-05-05

*Please contact our sales team for conditions and delivery times.

*Consultez notre équipe commerciale pour connaître les conditions et les délais de livraison.

Orbit Bollard Cover
Ø116mm
48V

IP	IK		BREEAM	SWITCH CCT	SEA SIDE SUITABLE		
66	10			2700-3200-4000			

● ○ ● ● ● ● ● ●
 Z5 14* 60* 34* J6* E3* DL*

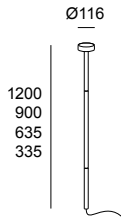

LED								
K	CRI	W	Real Lm	Code				
2700-3000-4000	80	3.2	268	10-E026	J6			PWM 48VDC
					E3			
					DL - EH	14		
					60	34		

The indicated flux corresponds to the core temperature.
 Le flux indiqué correspond à la température centrale.

Orbit Bollard Small Hole Cover
Ø116mm
48V

IP	IK		BREEAM	SWITCH CCT	SEA SIDE SUITABLE		
66	10			2700-3200-4000			

● ○ ● ● ● ● ● ●
 Z5 14* 60* 34* J6* E3* DL*

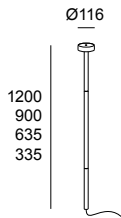

LED								
K	CRI	W	Real Lm	Code				
2700-3000-4000	80	3.2	270	10-E027	Z5			PWM 48VDC
					J6			
					E3	DL - EH	14	
					60	34		

The indicated flux corresponds to the core temperature.
 Le flux indiqué correspond à la température centrale.

Orbit Bollard Big Hole Cover
Ø116mm
48V

IP	IK		BREEAM	SWITCH CCT	SEA SIDE SUITABLE		
66	10			2700-3200-4000			

● ○ ● ● ● ● ● ●
 Z5 14* 60* 34* J6* E3* DL*

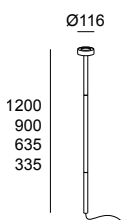

LED								
K	CRI	W	Real Lm	Code				
2700-3000-4000	80	3.2	293	10-E028	Z5			PWM 48VDC
					J6			
					E3	DL - EH	14	
					60	34		

The indicated flux corresponds to the core temperature.
 Le flux indiqué correspond à la température centrale.

Required fixing accessories
Accessoires de fixation nécessaires



Fixing base / Base de fixation
 Z5 ● **71-E636-Z5-00** E3 ● * **71-E636-E3-00** 14 ○ * **71-E636-14-00** 34 ● * **71-E636-34-00**
 J6 ● * **71-E636-J6-00** DL ● * **71-E636-DL-00** 60 ● * **71-E636-60-00**



235mm spiked post / Piquet de 235 mm **71-9997-05-05**

Power supplies
Sources d'alimentation

P. 985



ON-OFF Max.60W **71-B663-00-00**
 DALI-2 / IP67

BODY MAT	DIF MAT		50000h	3
AL	PC		L80 B20	MacAdam

Orbit Lampost Covered Ø202mm 2300mm

IP	IK	BREEAM	SWITCH CCT	SEA SIDE	LED	DRIVER
66	10		2700-3200-4000	SUITABLE		

Z5 14* 60* 34* J6* E3* DL*

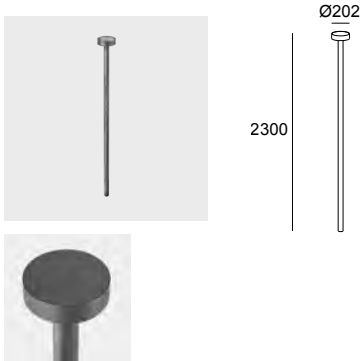

LED						
K	CRI	W Total	Real Lm	Code		
2700-3200-4000	80	24	1485	55-E097 - DL - EH	Z5 J6 E3	ON-OFF 100-240V
					14 60 34	

The indicated flux corresponds to the core temperature.
Le flux indiqué correspond à la température centrale.

Orbit Lampost Small Hole Cover Ø202mm 2300mm

IP	IK	BREEAM	SWITCH CCT	SEA SIDE	LED	DRIVER
66	10		2700-3200-4000	SUITABLE		

Z5 14* 60* 34* J6* E3* DL*

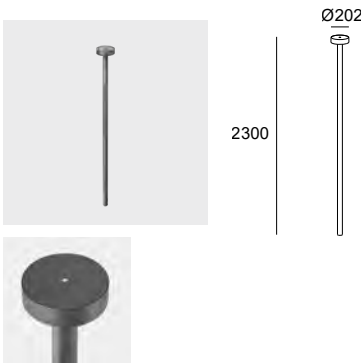

LED						
K	CRI	W Total	Real Lm	Code		
2700-3200-4000	80	24	1489	55-E098 - DL - EH	Z5 J6 E3	ON-OFF 100-240V
					14 60 34	

The indicated flux corresponds to the core temperature.
Le flux indiqué correspond à la température centrale.

Orbit Lampost Big Hole Cover Ø202mm 2300mm

IP	IK	UGR	BREEAM	SWITCH CCT	SEA SIDE	LED	DRIVER
66	10	<22		2700-3200-4000	SUITABLE		

Z5 14* 60* 34* J6* E3* DL*

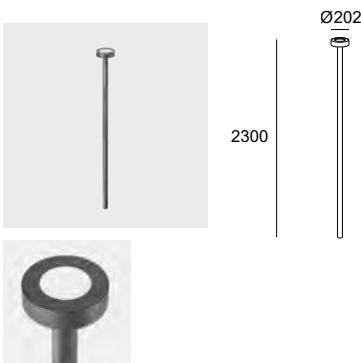

LED						
K	CRI	W Total	Real Lm	Code		
2700-3200-4000	80	24	1672	55-E099 - DL - EH	Z5 J6 E3	ON-OFF 100-240V
					14 60 34	

The indicated flux corresponds to the core temperature.
Le flux indiqué correspond à la température centrale.

*Please contact our sales team for conditions and delivery times.

*Consultez notre équipe commerciale pour connaître les conditions et les délais de livraison.

Lyon

Essential
SOLUTION

Designed by LedsC4 Architectural

Adequate luminous flux to lengthen the points of light Flux lumineux idéal pour espacer les points lumineux

Boasting a timeless design and features that have been specially developed to achieve a good light flux, Lyon is the perfect collection for general lighting of large areas using only a few points of light.

Avec son design intemporel et ses caractéristiques spécialement développées pour assurer un bon flux lumineux, Lyon est la collection parfaite pour l'éclairage général de vastes espaces à l'aide d'un nombre réduit de points lumineux.



900 mm

1810 mm

2310 mm





Lyon Bollard 900mm

BODY MAT
AL

DIF MAT
PC

IP
66

IK
10



BREEAM

50000h
L80 B20

3
MacAdam

SEA SIDE
SUITABLE

PRO-BASE



Z5 34

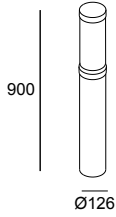

LED										
K	CRI	W Total	Real Lm	Code						
2700-3200-4000	80	21.46	1937	55-E092 - Z5 - EH		34	ON-OFF	100-240V		

The indicated flux corresponds to the core temperature.
Le flux indiqué correspond à la température centrale.

Fixing accessories Accessoires de fixation



Fixing bolts
Boulons de fixation

71-E092-48-48

Lights up to 26 m² Éclaire jusqu'à 26 m²

Light effect generated with 60-E001 head and 81-9914 column.
Effet lumineux créé par la tête 60-E001 et le mât 81-9914.

Switch CCT



4K
3.2K
2.7K

Lyon Lampost Outdoor LED

	BODY MAT AL	DIF MAT PC	SEA SIDE SUITABLE	IP 65	IK 10	UGR <16		50000h L80 B20	BREEAM	3 MacAdam		
--	----------------	---------------	-----------------------------	----------	----------	------------	--	-------------------	--------	--------------	--	--

Z5 34

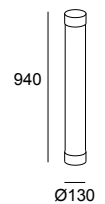

LED						
K	CRI	W Total	Real Lm	Code		
2700-3000-4000	80	55	4741	60-E001 - Z5 34 - EH	DALI-2 100-240V	

The indicated flux corresponds to the core temperature.
Le flux indiqué correspond à la température centrale.

Lyon Lampost Outdoor Base 1810mm

BODY MAT AL	DIF MAT PC	SEA SIDE SUITABLE
----------------	---------------	-----------------------------

Z5 34

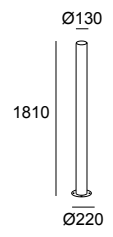

Code	
81-9914	Z5 - Z5 34 - 34

Lyon Lampost Outdoor Base 2310mm

BODY MAT AL	DIF MAT PC	SEA SIDE SUITABLE
----------------	---------------	-----------------------------

Z5 34

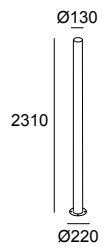

Code	
81-9915	Z5 - Z5 34 - 34

Fixing accessories Accessoires de fixation



Fixing bolts
Boulons de fixation

48

71-9957-48-48

Repair accessories Accessoires de réparation



Z5 anti-scratch paint
Peinture Z5 anti-rayures

Z5

71-E117-Z5-00

Juncus

Designed by Luca Turini



+ Juncus

Integration with the surrounding area Mimétisme avec l'environnement

Inspired by natural rushes, this collection blends seamlessly with the vegetation and environment. The possibility of adjusting the height of the bollards, the mobility of the heads and their brown finish allow these luminaires to blend in fully with natural landscapes.

Inspirée des roseaux naturels, cette collection se fond parfaitement dans la végétation et le décor. La possibilité de régler la hauteur des bornes, la mobilité des têtes et sa finition marron, lui permettent de s'intégrer pleinement dans un paysage naturel.



Juncus 1 Head

Adjustable height
Hauteur réglable

3530 mm

Juncus 2 Heads

Adjustable height
Hauteur réglable

Juncus 3 Heads

Fixed height
Hauteur fixe

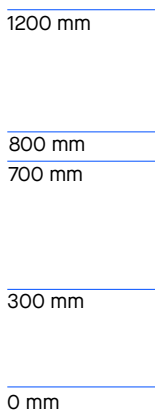





Choice of lighting mode Choix du mode d'éclairage

Designed to easily choose and switch between lighting with maximum visual comfort or with maximum light beam emission, without the need for tools.

Conçu pour choisir et changer facilement, sans outils, entre deux modes d'éclairage : avec un maximum de confort visuel ou avec un maximum d'émission du faisceau lumineux.

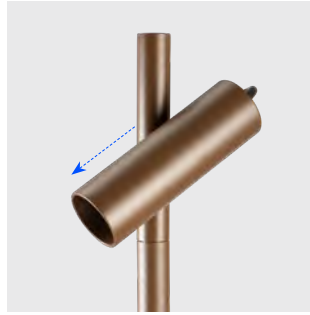

Maximum visual comfort mode
(sunken LED)
Mode Confort visuel maximal
(LED enfoncée)

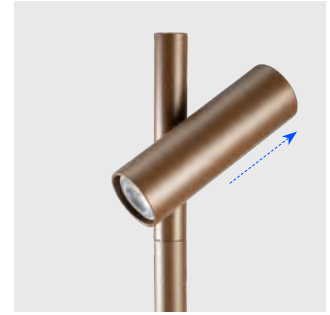

Maximum light beam emission mode
(extended LED)
Mode Émission de faisceau maximale
(LED étendue)

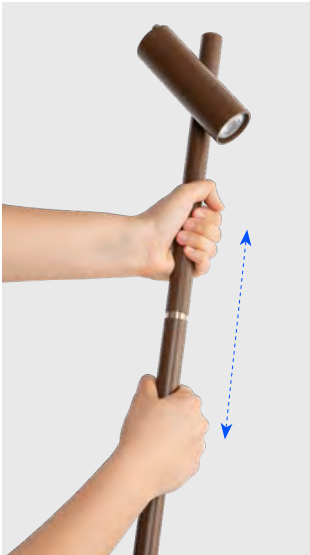

Adjustable height
Hauteur réglable

Independent swivel heads Têtes à inclinaison indépendante

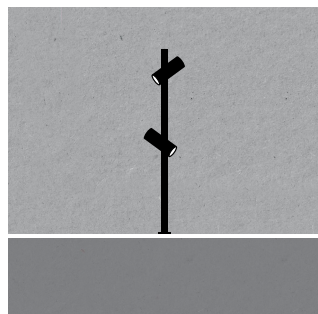
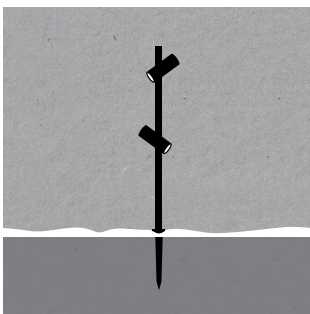

Juncus 1 Head

BODY MAT	DIF MAT	2	NEW	IP	IK	LOW			SEA SIDE		LED
AL	GLA	MacAdam		65	10	FLICKER		1.5 m	SUITABLE	360°	

J6

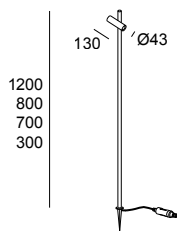

LED										
K	CRI	W Total	Real Lm	Optics	Code					
2700	80	8.3	390	30°	10-E013 - J6 - CK CL	ON-OFF 100-240V				
3000	80	8.3	418	30°						

Juncus 2 Heads

BODY MAT	DIF MAT	2	NEW	IP	IK		BREEAM		SEA SIDE		LED
AL	GLA	MacAdam		66	10			1 m	SUITABLE	360°	

J6

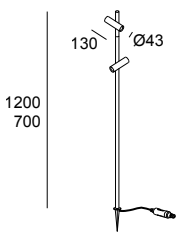

LED										
K	CRI	W Total	Real Lm	Optics	Code					
2700	80	15.2	780	30°	10-E018 - J6 - CK CL	ON-OFF 100-240V				
3000	80	15.2	836	30°						

Juncus 3 Heads

BODY MAT	DIF MAT	2	NEW	IP	IK		BREEAM		SEA SIDE		LED
AL	GLA	MacAdam		66	5				SUITABLE	±90°	

J6

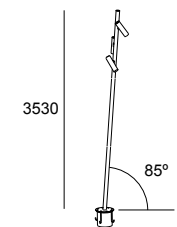
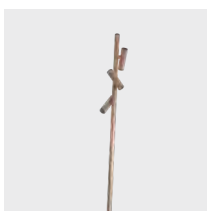

LED										
K	CRI	W Total	Real Lm	Optics	Code					
2700	80	41	3462	45°	60-E057 - J6 - CK CL	ON-OFF 100-240V				
3000	80	41	3712	45°						

Juncus 1 Head

Juncus 2 Heads

Juncus 3 Heads

Drivers

Drivers

P. 984



IP67 Driver & Connector
Driver IP67 & connecteur

Included

Included

-

Fixing accessories

Accessoires de fixation



Spiked post
Piquet

Included

Included

-



Fix base
Base fixe

71-E636-J6-J6

71-E636-J6-J6

-



Bolts and template
Boulons et gabarit

-

-

Included

Invisible

Designed by Francesc Vilaró



+ Invisible

Minimalism with a floating point of light Minimalisme avec point lumineux flottant

The Invisible range is a landmark collection for its unique and functional design featuring pure, simple lines. Understated and minimalist, it blends into settings creating an almost floating point of light that is ideal for gardens and terraces.

La collection Invisible est une référence de par son design unique et fonctionnel, aux lignes simples et épurées. Discrète et minimaliste, elle se fond dans le décor en créant un point lumineux presque flottant, idéal pour les jardins et les terrasses.



600 mm

Adjustable

2100 mm

2100 mm

1230 mm

830 mm

730 mm

600 mm

330 mm

0 mm

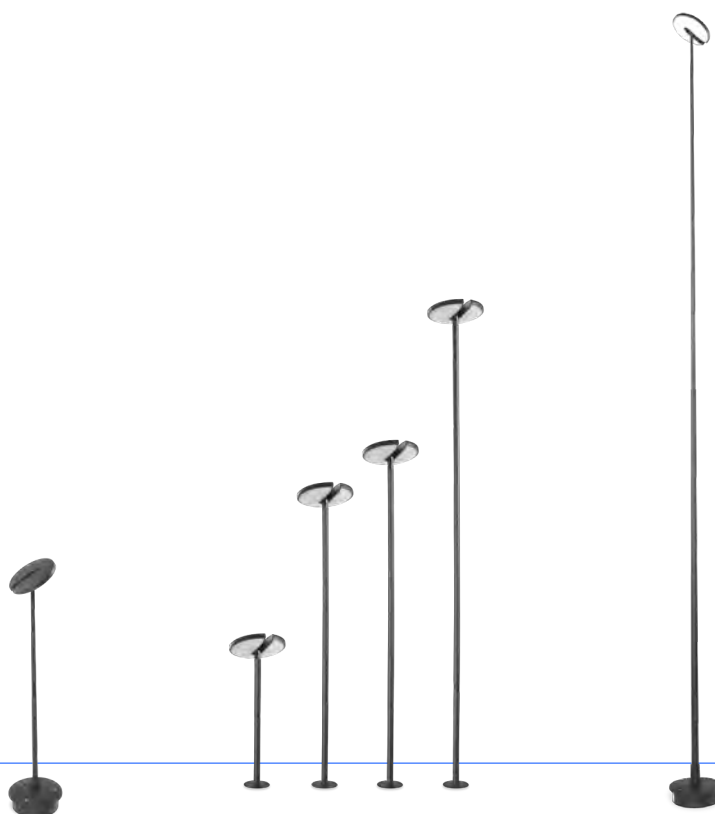



Soft and flattering light Lumière douce et agréable

Opal diffuser for more even and subdued lighting.

Diffuseur opalin pour une lumière plus homogène et atténuée.



Swivel head Tête basculante

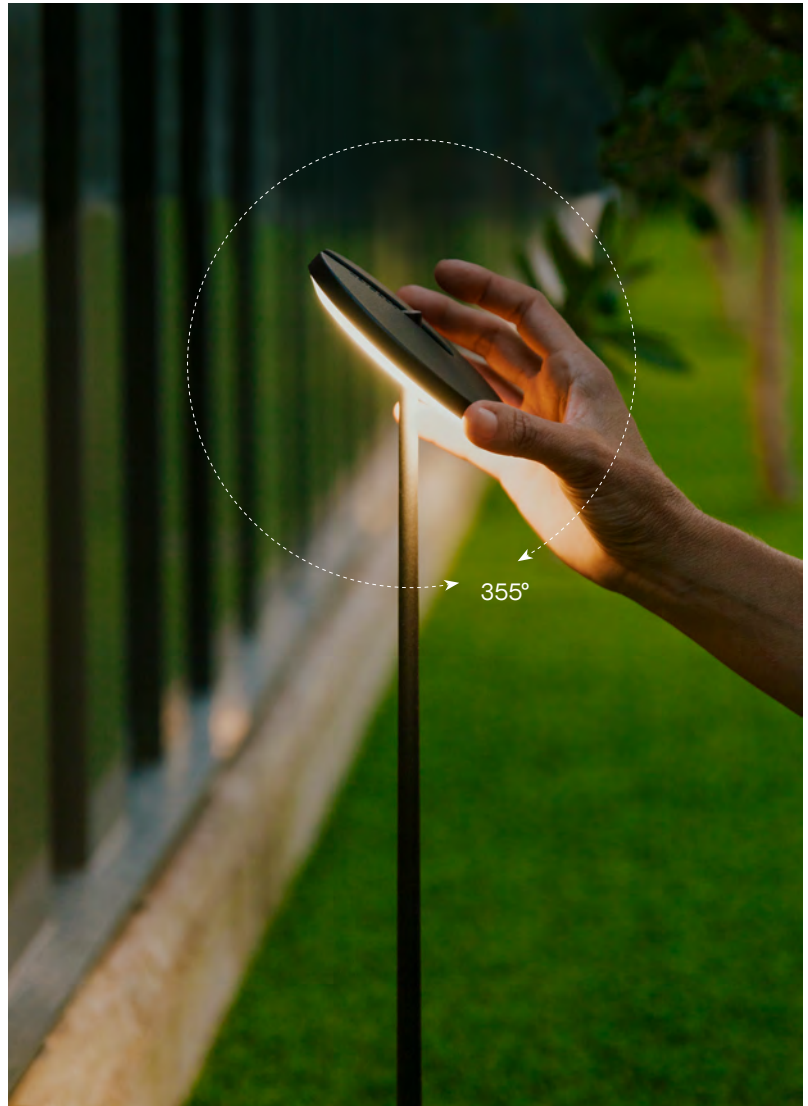

Invisible 60mm in Girona private residence project.

Photography: Eulàlia Prat.

Invisible 60 mm en projet, Résidence privée de Gérone.

Photographie : Eulàlia Prat.

Invisible 600mm

BODY MAT	DIF MAT		3	IP	IK	SEA SIDE SUITABLE	355°	LED
AL	PC		MacAdam	54	04			

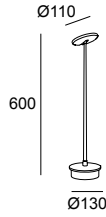

LED							
K	CRI	W Total	Real Lm	Code			
2700	80	10.7	421	55-9733 - 05 - CK M1		ON-OFF	100-240V
3000	80	10.7	469				

Invisible 2100mm

BODY MAT	DIF MAT		3	IP	IK	SEA SIDE SUITABLE	355°	LED
AL	PC		MacAdam	54	04			

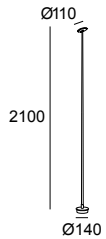

LED							
K	CRI	W Total	Real Lm	Code			
2700	80	10.7	421	25-9733 - 05 - CK M1		ON-OFF	100-240V
3000	80	10,7	469				

Invisible Adjustable

BODY MAT	DIF MAT		3	IP	IK	SEA SIDE SUITABLE	355°	LED
AL	PC		MacAdam	54	04			

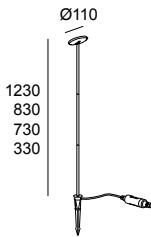
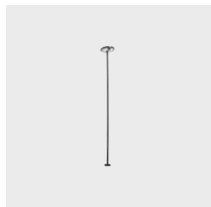

LED							
K	CRI	W Total	Real Lm	Code			
2700	80	10.7	421	10-9733 - 05 - CK CL		ON-OFF	100-240V
3000	80	10,7	469				

Invisible
600mm / 2100mm

Invisible
Adjustable

Drivers



IP67 Driver & Connector
Driver IP67 & connecteur

-

Included

Fixing accessories

Accessoires de fixation



Spiked post
Piquet

-

Included

Max

Designed by LedsC4 Architectural



+ Max

Wall Fixture
P. 788



Ceiling
P. 852



Spotlight
P. 540



Downlight
P. 598



Uplight
P. 630



Precision landscape lighting Éclairage paysager de précision

The Max bollard offers an extensive range of options and accessories with very precise angles of light. Its minimal residual light and very compact design make it an ideal choice for the most select and challenging exteriors.

La borne Max propose un vaste éventail d'options et d'accessoires avec des angles d'éclairage très précis. Grâce à sa lumière résiduelle minimale et à son design très compact, c'est une option idéale pour les extérieurs chics et exigeants.





**Max Small
Bollard**

BODY MAT AL	DIF MAT GLA		50000h L80 B20	2 MacAdam	IP 66	IK 04	 1 m	SEA SIDE SUITABLE	 360°	
----------------	----------------	--	-------------------	--------------	----------	----------	---------	----------------------	----------	--

Code example / Exemple d'élaboration d'une référence: **BA17-P2V8S1BBZ5**

Model	W	K	CRI	Optics	Real Lm	Source	Finishes	
BA17 - Bollard Spike Ø30mm 	Constant Current 700mA							
	P2P8	2.5	2200	80	S1 10°	163	BB 3V/max.700mA	14*
	P2V8	2.2	2700	80	S2 15°	185		34*
	P2W8	2.2	3000	80	M3 32°	191		60*
	P2X8	2.2	4000	80	F2 53°	158		DL*
	Constant Voltage 24V							
	P3V8	2.5	2700	80	S3 19°	94	BB PWM 24VDC	E3*
	P3W8	2.5	3000	80	M3 32°	97		J6*
	P3X8	2.5	4000	80	F2 51°	87		Z5

**Max Medium
Bollard**

BODY MAT AL	DIF MAT GLA		50000h L80 B20	2 MacAdam	IP 66	IK 10	 1 m	SEA SIDE SUITABLE	 360°		
----------------	----------------	--	-------------------	--------------	----------	----------	---------	----------------------	----------	--	--

Code example / Exemple d'élaboration d'une référence: **A117-P4V9S1BBZ5**

Model	W	K	CRI	Optics	Real Lm	Source	Finishes	
A117 - Bollard Spike Ø58mm 	Constant Current 350mA Wired in series							
	P4V9	4	2700	90	S1 9°	286	BB 12V/max.350mA	14*
	P4W9	4	3000	90				34*
	P4X9	4	4000	90				60*
	P7P8	6.5	2200	80	S2 17°	519	BB 18V/max.350mA	DL*
	P7V9	6.5	2700	90	M2 27°	459		E3*
	P7W9	6.5	3000	90	F1 50°	423		J6*
	P7X9	6.5	4000	90				Z5
	Constant Voltage 24V Wired in parallel							
	P6V9	6	2700	90	S1 9°	204	BB PWM 24VDC	
	P6W9	6	3000	90				
	P6X9	6	4000	90				
	P8V9	7.9	2700	90	S2 17°	519	BB PWM 24VDC	
	P8W9	7.9	3000	90	M2 27°	459		
P8X9	7.9	4000	90	F1 50°	423			

* Please contact our sales team for conditions and delivery times.
 * Consultez notre équipe commerciale pour connaître les conditions et les délais de livraison.

Max Big Bollard

BODY MAT AL	DIF MAT GLA		50000h L80 B20	2 MacAdam	IP 66	IK 10	 1 m	 SEA SIDE SUITABLE	 360°		 DIM
----------------	----------------	--	-------------------	--------------	----------	----------	---------	--------------------------	----------	--	---------

Code example / Exemple d'élaboration d'une référence: **AT17-18V9S3BBZ5**

Model		W	K	CRI	Optics	Real Lm	Source	Finishes
AT17 - Ø82mm 	Constant Current							
	13V9	13,7	2700	90	S1 10°	931 - 1054	BB 36V/max.350mA	14*
	13W9	13,7	3000	90				34*
	13X9	13,7	4000	90				60*
	18P8	17,3	2200	80	S3 21°	1844 - 2126	BB 36V/max.500mA	DL*
	18V9	17,3	2700	90	M3 31°	1902 - 2191		E3*
	18W9	17,3	3000	90	F1 40°	1265 - 1812		J6*
	18X9	17,3	4000	90				Z5
	Constant Voltage 24V							
	14V9	13,8	2700	90	S3 16°	1086	BB PWM 24VDC	
	14W9	13,8	3000	90	M2 28°	1076		
	14X9	13,8	4000	90	F2 51°	1120		

* Please contact our sales team for conditions and delivery times.
* Consultez notre équipe commerciale pour connaître les conditions et les délais de livraison.

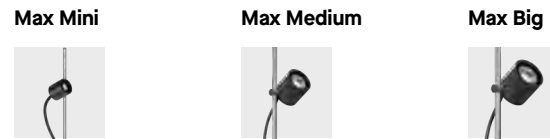

Connection accessories Accessoires de connexion

	Max Mini	Max Medium	Max Big
IP67 connector (1 input + 1 output) Ø 5,5 - 7,5mm, 3 poles Connecteur IP67 (1 entrée + 1 sortie) Ø 5,5 - 7,5 mm, 3 pôles	71-E510-00-00	71-E510-00-00	71-E510-00-00
IP67 connector (1 input + 2 output) Ø 5,5 - 7,5mm, 3 poles Connecteur IP67 (1 entrée + 2 sortie) Ø 5,5 - 7,5 mm, 3 pôles	71-E511-00-00 Not for Constant Current	71-E511-00-00 Not for Constant Current	71-E511-00-00 Not for Constant Current
IP68 connector (1 input + 1 output) Ø 5,5-11,5 mm, 4 poles Connecteur IP68 (1 entrée + 1 sortie) Ø 5,5 - 11,5 mm, 4 pôles	71-E512-00-00	71-E512-00-00	71-E512-00-00
IP68 connector (1 input + 2 outputs) Ø 5,5-11,5 mm, 3 poles Connecteur IP68 (1 entrée + 2 sorties) Ø 5,5 - 11,5 mm, 3 pôles	71-E513-00-00 Not for Constant Current	71-E513-00-00 Not for Constant Current	71-E513-00-00 Not for Constant Current
IP68 anti-condensation connector (1 input + 1 output) Ø 5,5-12 mm, 4 poles Connecteur anticondensation IP68 (1 entrée + 1 sortie) Ø 5,5 - 12 mm, 4 pôles	71-E112-00-00 Not for Constant Current	71-E112-00-00 Not for Constant Current	71-E112-00-00 Not for Constant Current
IP68 anti-condensation connector (1 input + 3 outputs) Ø 5,5-12 mm, 4 poles Connecteur anticondensation IP68 (1 entrée + 3 sorties) Ø 5,5 - 12 mm, 4 pôles	71-E122-00-00	71-E122-00-00	71-E122-00-00
IP68 connection box (1 input + 5 outputs) Ø 6,5-11 mm, 6 poles Boîtier de raccordement IP67 (1 entrée + 5 sorties) Ø 6,5 - 11 mm, 6 pôles	-	71-9199-05-05	71-9199-05-05

Max Mini



Max Medium









Max Big







Lens accessories

Accessoires optiques

	Wall washer diffuser (5u.) Diffuseur lèche-mur (5 u.)		71-E462-00-00	71-E463-00-00	71-E464-00-00
	Honeycomb panel (5u.) Grille en nid d'abeille (5 u.)		71-E422-00-00	71-E131-00-00	71-E263-00-00
	Square diffuser (5u.) Diffuseur carré (5 u.)		71-E421-00-00	71-E135-00-00	71-E262-00-00
	Elliptical diffuser (5u.) Diffuseur elliptique (5 u.)		71-E420-00-00	71-E141-00-00	71-E261-00-00
	Opal diffuser (5u.) Diffuseur opalin (5 u.)		71-E419-00-00	71-E133-00-00	71-E260-00-00
	Visor Visière	Z5 ●	71-E417-Z5-00	71-E145-Z5-Z5	71-E259-Z5-00
		J6 ● *	71-E417-J6-00	71-E145-J6-J6	71-E259-J6-00
		E3 ● *	71-E417-E3-00	71-E145-E3-E3	71-E259-E3-00
		DL ● *	71-E417-DL-00	71-E145-DL-DL	71-E259-DL-00
		14 ○ *	71-E417-14-00	71-E145-14-14	71-E259-DL-00
		60 ● *	71-E417-60-00	71-E145-60-60	71-E259-60-00
		34 ● *	71-E417-34-00	71-E145-34-34	71-E259-60-00
	Cylindrical visor Visière cylindrique	Z5 ●	71-E605-Z5-00	71-E606-Z5-00	71-E607-Z5-00
		J6 ● *	71-E605-J6-00	71-E606-J6-00	71-E607-J6-00
		E3 ● *	71-E605-E3-00	71-E606-E3-00	71-E607-E3-00
		DL ● *	71-E605-DL-00	71-E606-DL-00	71-E607-DL-00
		14 ○ *	71-E605-14-00	71-E606-14-00	71-E607-DL-00
		60 ● *	71-E605-60-00	71-E606-60-00	71-E607-60-00
		34 ● *	71-E605-34-00	71-E606-34-00	71-E607-60-00





Power supplies
Sources d'alimentation

	ON-OFF IP20	Max.20W	71-B650-00-00		DALI2 IP20	Max.60W	71-B652-00-00
		Max.30W	71-B640-00-00			Max.150W	71-B653-00-00
		Max.100W	71-B641-00-00			Max.250W	71-B654-00-00
		Max.150W	71-B642-00-00			Max.60W	71-B655-00-00
		Max.250W	71-B643-00-00			Max.160W	71-B656-00-00
	ON-OFF IP67	Max.30W	71-B644-00-00		DALI2 IP67	Max.240W	71-B675-00-00
		Max.60W	71-B645-00-00				
		Max.100W	71-B646-00-00				
		Max.160W	71-B647-00-00				
		Max.240W	71-B648-00-00				

Constant Current

	Max Mini	Max Medium P4	Max Medium P7	Max Big 13W	Max Big 18W
					

Drivers

	ON-OFF IP20	71-B682-00-00 ✂	71-A652-00-00 ✂	71-6652-00-00 ✂	71-6652-00-00 ✂	71-7551-00-00 ✂
				Min.2 - Max.2		
	ON-OFF IP68	71-3542-00-00 ✂	71-3542-00-00 ✂	71-3542-00-00 ✂	-	-
		Min.1 - Max.22	Min.1 - Max.6	Min.1 - Max.3		
	DALI2 IP20	71-E014-00-00	71-E079-00-00 ✂	71-E079-00-00 ✂	71-E079-00-00 ✂	-
		Min.2 - Max.4	Min.1 - Max.4	Min.1 - Max.2		
	DALI2 IP68	71-A190-00-00	71-A192-00-00	71-A192-00-00	71-A191-00-00 ✂	71-A192-00-00 ✂
		Min.2 - Max.4	Min.1 - Max.3	Min.1 - Max.2		
	DALI2 IP68	71-E080-00-00	71-E083-00-00	71-E083-00-00	71-E083-00-00	71-E085-00-00 ✂
		Min.1 - Max.13	Min.1 - Max.4	Min.1 - Max.2		

Connective controllers
Contrôleurs connectés

	Consult the available control systems / Consultez les systèmes de contrôle disponibles: DALI2 / DALI2 Bluetooth wireless / Sans fil Bluetooth DMX / DMX Autonomous / Autonome
-------------------------------------------------------------------------------------	--------------------------------------------------------------------------------------------------------------------------------------------------------------------------------------------------

Eko

Designed by LedsC4 Architectural



Spotlight
P. 550



Downlight
P. 608



Wall Fixtures
P. 794



Ceiling
P. 856



An indispensable bollard with a wide range of features Une borne essentielle qui offre de nombreuses prestations

This collection is perfect for projects seeking an affordable, highly reliable solution for various applications. The Eko bollards come in both the Comfort version, offering downward light, and the Efficiency version, with forward light. They are easy to install and maintain.

Cette collection est idéale pour les projets qui cherchent une solution abordable doublée d'un maximum de fiabilité pour répondre à différentes utilisations. Les bornes Eko sont disponibles en version Comfort avec un éclairage vers le bas et en version Efficiency à éclairage vers l'avant. Facilité d'installation et d'entretien.

Standard

Inclined



14



34



DL



E3



J6



Z5



60





Eko Bollard Standard

IP	BODY MAT	IK	DIF MAT	
65	AL	07	PC	

● ● ● ● ● ● ● ●
60 Z5* 14* 34* J6* E3* DL*

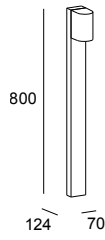

GU10	
W	Code
	60
	Z5
	J6
Max. 8	55-E110 - E3 - 37
	DL
	14
	34

Eko Bollard Inclined

IP	BODY MAT	IK	DIF MAT	
65	AL	07	PC	

● ● ● ● ● ● ● ●
60 Z5* 14* 34* J6* E3* DL*

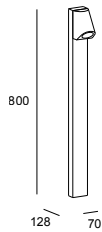

GU10	
W	Code
	60
	Z5
	J6
Max. 8	55-E111 - E3 - 37
	DL
	14
	34

Fixing accessories

Accessoires de fixation



Fixing bolts
Boulons de fixation

71-E635-00-00

Repair accessories

Accessoires de réparation



Bulb extraction kit (suction cup + clamp)
Kit d'extraction de l'ampoule (ventouse + pince)

71-E634-00-00



Maximum intervals between bollards Espacement maximum des bornes

The technical features of Rek make it possible to illuminate up to 40 m² using only two bollards. Offering excellent homogeneity, this piece meets the requirements of the CTE (Building Technical Code): it offers 20 Lux on average with more than 40% uniformity.

Les prestations techniques de Rek permettent d'éclairer jusqu'à 40 m² avec seulement deux bornes. Doté d'une excellente homogénéité, ce modèle respecte les exigences du Code technique de la construction (CTE) obligatoire en Espagne : il offre 20 lux en moyenne avec 40 % d'uniformité.

180°

360°



14

34

DL

E3

J6

Z5

60





Perfect for transit zones
Parfait pour les allées

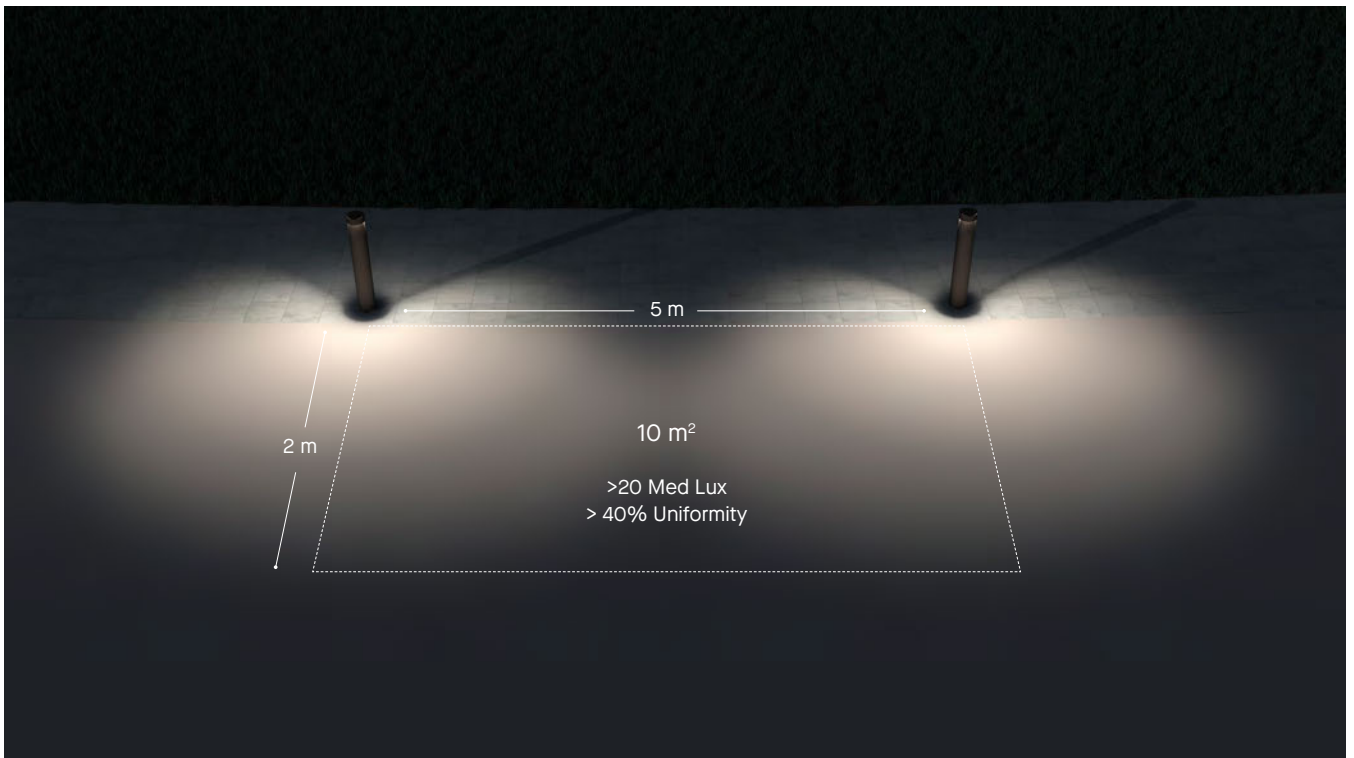

Amber

2700K

3000K

4000K

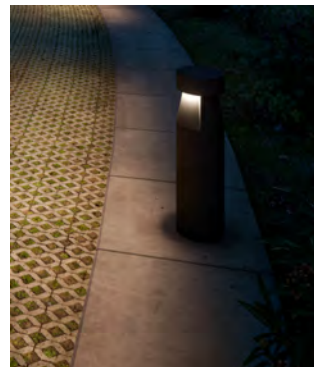
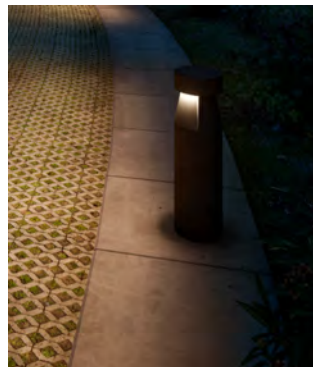

Featuring Amber LED, known for
its eco-friendly properties
LED ambre, l'éclairage plus
respectueux de l'environnement

Available with various lighting control systems
 Disponible avec différents systèmes de variation

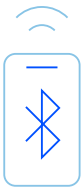

Available in DALI-2 and Bluetooth Casambi.
 Disponible en DALI-2 et Bluetooth Casambi.

Rek 533mm
180°

BODY MAT AL	DIF MAT PC		50000h L80 B20	3 MacAdam	IP 66	IK 10	SEA SIDE SUITABLE	PRO-BASE	LED	DRIVER
----------------	---------------	--	-------------------	--------------	----------	----------	----------------------	----------	-----	--------

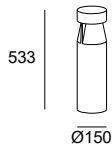

LED						
K	CRI	W Total	Real Lm	Code		
2700	80	13.7	325	55-E025	Z5	
				55-E026	J6	
				55-E027	E3	ON-OFF 100-240V
					- DL - CK	DALI-2 220-240V
3000	80	13.7	325	55-E025	Z5	
				55-E026	J6	
				55-E027	E3	ON-OFF 100-240V
					- DL - CL	DALI-2 220-240V
4000	80	13.7	325	55-E025	Z5	
				55-E026	J6	
				55-E027	E3	ON-OFF 100-240V
					- DL - CM	DALI-2 220-240V
Amber	80	14.5	263	55-E025	Z5	
				55-E026	J6	
				55-E027	E3	ON-OFF 100-240V
					- DL - CP	DALI-2 220-240V
					14	CASAMBI 220-240V
					60	
					34	

**Rek 533mm
360°**

BODY MAT
AL

DIF MAT
PC



50000h
L80 B20

3
MacAdam

IP
66

IK
10

SEA SIDE SUITABLE

PRO-BASE

LED

DRIVER

Z5 14* 60* 34* J6* E3* DL*

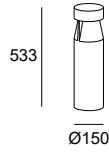

LED						
K	CRI	W Total	Real Lm	Code		
2700	80	27	650	55-E028	Z5	
				55-E029	J6	
				55-E030	E3	ON-OFF 100-240V
					- DL - CK	DALI-2 220-240V
3000	80	27	650	55-E028	Z5	
				55-E029	J6	
				55-E030	E3	ON-OFF 100-240V
					- DL - CL	DALI-2 220-240V
4000	80	27	650	55-E028	Z5	
				55-E029	J6	
				55-E030	E3	ON-OFF 100-240V
					- DL - CM	DALI-2 220-240V
Amber	80	27	526	55-E028	Z5	
				55-E029	J6	
				55-E030	E3	ON-OFF 100-240V
					- DL - CP	DALI-2 220-240V
					14	CASAMBI 220-240V
					60	
					34	

Rek 933mm
180°

BODY MAT
AL

DIF MAT
PC



50000h
L80 B20

3
MacAdam

IP
66

IK
10



Z5 14* 60* 34* J6* E3* DL*

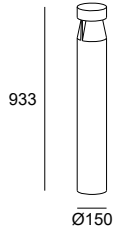

LED						
K	CRI	W Total	Real Lm	Code		
2700	80	19.5	459	55-E031	Z5	
				55-E032	J6	
				55-E033	E3	ON-OFF 100-240V
				- DL - CK	E3	DALI-2 220-240V
				14	E3	CASAMBI 220-240V ⚡
3000	80	19.5	459	55-E031	Z5	
				55-E032	J6	
				55-E033	E3	ON-OFF 100-240V
				- DL - CL	E3	DALI-2 220-240V
				14	E3	CASAMBI 220-240V ⚡
4000	80	19.5	459	55-E031	Z5	
				55-E032	J6	
				55-E033	E3	ON-OFF 100-240V
				- DL - CM	E3	DALI-2 220-240V
				14	E3	CASAMBI 220-240V ⚡
Amber	80	14.5	263	55-E031	Z5	
				55-E032	J6	
				55-E033	E3	ON-OFF 100-240V
				- DL - CP	E3	DALI-2 220-240V
				14	E3	CASAMBI 220-240V ⚡

**Rek 933mm
360°**

BODY MAT
AL

DIF MAT
PC



50000h
L80 B20

3
MacAdam

IP
66

IK
10

SEA SIDE SUITABLE

PRO-BASE

LED

DRIVER

Z5 14* 60* 34* J6* E3* DL*

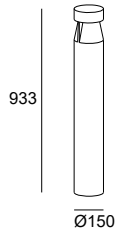

LED						
K	CRI	W Total	Real Lm	Code		
2700	80	40	918	55-E035	Z5	
				55-E036	J6	
				55-E037	E3	ON-OFF 100-240V
					- DL - CK	DALI-2 220-240V
					14	CASAMBI 220-240V ⚡
				60		
				34		
3000	80	40	918	55-E035	Z5	
				55-E036	J6	
				55-E037	E3	ON-OFF 100-240V
					- DL - CL	DALI-2 220-240V
					14	CASAMBI 220-240V ⚡
				60		
				34		
4000	80	40	918	55-E035	Z5	
				55-E036	J6	
				55-E037	E3	ON-OFF 100-240V
					- DL - CM	DALI-2 220-240V
					14	CASAMBI 220-240V ⚡
				60		
				34		
Amber	80	27	526	55-E035	Z5	
				55-E036	J6	
				55-E037	E3	ON-OFF 100-240V
					- DL - CP	DALI-2 220-240V
					14	CASAMBI 220-240V ⚡
				60		
				34		

Fixing accessories
Accessoires de fixation



Fixing bolts
Boulons de fixation

71-E092-48-48

* Please contact our sales team for conditions and delivery times.
* Consultez notre équipe commerciale pour connaître les conditions et les délais de livraison.

Newton

Designed by LedsC4 Architectural

Ideal solution for lighting large areas Solution idéale pour l'éclairage de vastes espaces

Newton's technical features and its composed, timeless aesthetic make this collection the ideal solution for a wide variety of projects. Newton Led Pro is particularly suitable for lighting large outdoor spaces such as shopping centres, universities, residential areas or resorts thanks to its light package with almost 2500 Lm. Its LED or E27 bulb versions are ideal for smaller spaces.

Les caractéristiques techniques de la collection et son esthétique sobre et intemporelle font de Newton une solution idéale pour un vaste éventail de projets. Newton Led Pro est particulièrement adapté à l'éclairage de vastes espaces extérieurs tels que centres commerciaux, universités, zones résidentielles ou complexes hôteliers, grâce à sa charge lumineuse de près de 2 500 lm. Ses versions LED ou à ampoule E27 sont idéales pour les espaces plus réduits.



Newton LED Pro

756

Newton LED

758

Newton E27

759

250 mm



250 mm



700 mm



800 mm



800 mm



1000 mm



28,2 W

12,7 W

Max. 23 W



360°



Z5

Newton

LED Pro

BODY MAT
AL

DIF MAT
PC



50000h
L80 B20

3
MacAdam



DALI-2 dimmable as standard
Variable DALI-2 de série



Newton LED Pro 250mm

IP 66	IK 10	LOW FLICKER	BREEAM		SEA SIDE SUITABLE	PRO-BASE	LED	DRIVER	DALI2
----------	----------	----------------	--------	--	----------------------	----------	-----	--------	-------

Z5



LED						
K	CRI	W Total	Real Lm	Code		
3000	80	25.1	2450	10-E016 - Z5 - CL	DALI-2 220-240V	

Newton LED Pro 700mm

IP 66	IK 10	LOW FLICKER	BREEAM		SEA SIDE SUITABLE	PRO-BASE	LED	DRIVER	DALI2
----------	----------	----------------	--------	--	----------------------	----------	-----	--------	-------

Z5

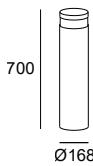

LED						
K	CRI	W Total	Real Lm	Code		
3000	80	25.1	2450	55-E016 - Z5 - CL	DALI-2 220-240V	

Newton LED Pro 1000mm

IP 66	IK 10	LOW FLICKER	BREEAM		SEA SIDE SUITABLE	PRO-BASE	LED	DRIVER	DALI2
----------	----------	----------------	--------	--	----------------------	----------	-----	--------	-------

Z5

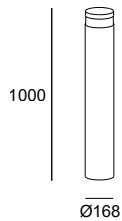

LED						
K	CRI	W Total	Real Lm	Code		
3000	80	25.1	2450	55-E054 - Z5 - CL	DALI-2 220-240V	

Fixing accessories Accessoires de fixation



Fixing bolts
Boulons de fixation

71-E006-48-48

Newton LED

BODY MAT	DIF MAT	
AL	PC	

Newton LED Pro 700mm

IP	IK	50000h	3		SEA SIDE SUITABLE	PRO-BASE	LED	DRIVER
65	08	L80 B20	MacAdam					

Z5



LED						
K	CRI	W Total	Real Lm	Code		
3000	80	13.9	573	10-9791 - Z5 - CL	ON-OFF	100-240V

Newton LED Pro 1000mm

IP	IK	50000h	3		SEA SIDE SUITABLE	PRO-BASE	LED	DRIVER
65	08	L80 B20	MacAdam					

Z5

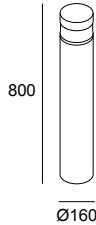

LED						
K	CRI	W Total	Real Lm	Code		
3000	80	13.9	573	55-9791 - Z5 - CL	ON-OFF	100-240V

Fixing accessories Accessoires de fixation



Fixing bolts
Boulons de fixation

71-E006-48-48

Newton E27

IP
65

IK
08



SEA SIDE
SUITABLE

PRO-BASE

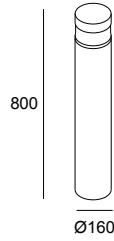

E27	
W	Code
Max. 15	55-9504 - Z5 - M2

Z5

Smart accessories

Accessoires Smart



E27 RGBW Wi-Fi light bulb
Ampoule E27 RGBW Wi-Fi

71-8219-00-00

Fixing accessories

Accessoires de fixation



Fixing bolts
Boulons de fixation

71-E013-48-48

Dan

Essential
SOLUTION

Designed by LedsC4 Architectural



+ Dan



Versatile and affordable Polyvalent et économique

Dan is a basic product that has been developed with special attention to the quality of light and visual comfort. With a sturdy structure, high protection against impact, dust and water, and a sleek design, the end result is a collection that offers both warmth and uniformity.

Dan est un produit d'entrée de gamme qui a été développé en veillant particulièrement à la qualité de la lumière et au confort visuel. Arborant une structure robuste, une haute protection face aux chocs et aux infiltrations de poussière et d'eau, ainsi qu'une ligne esthétique, le résultat final est une collection qui se démarque par sa chaleur et son uniformité.

Ideal for a vast range of settings Idéal pour différents environnements



Dan 700mm in Terrazas del Poniente Sur project in Cordoba. Photography: Jesús Granada.
Dan 700 mm en projet, Terrasses du Poniente Sur de Córdoba. Photographie : Jesús Granada.



Light shutter accessory included

Accessoire obturateur de lumière fourni

Using just one luminaire, you can illuminate forwards or in all directions.

Avec une seule référence, on peut éclairer uniquement vers l'avant ou dans toutes les directions

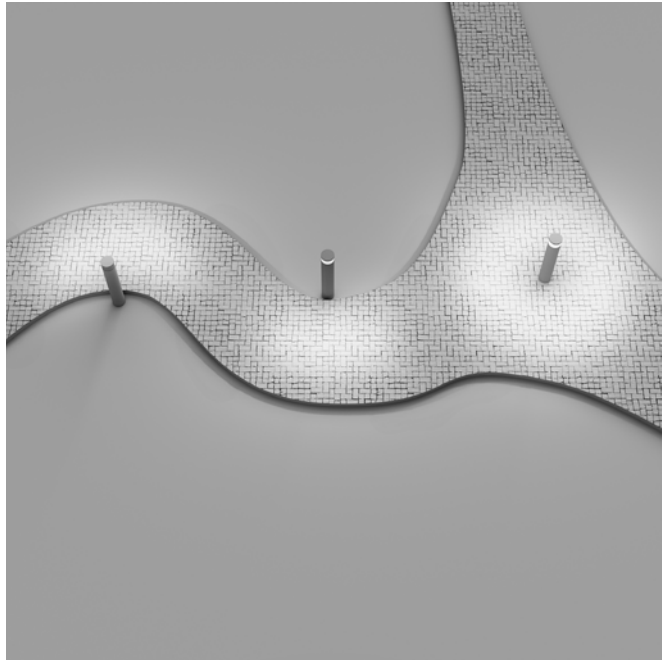

CCT switch included

Interrupteur CCT fourni

Choice of 3000K or 4000K

Permet de choisir entre 3 000 K et 4 000 K

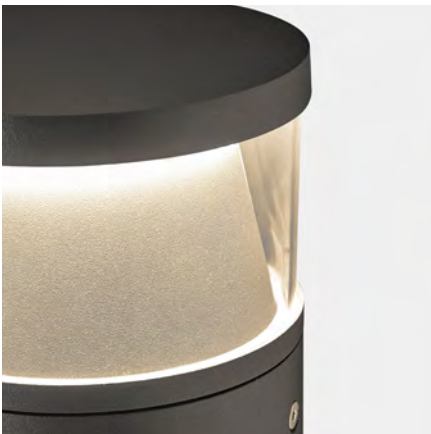

3000 K

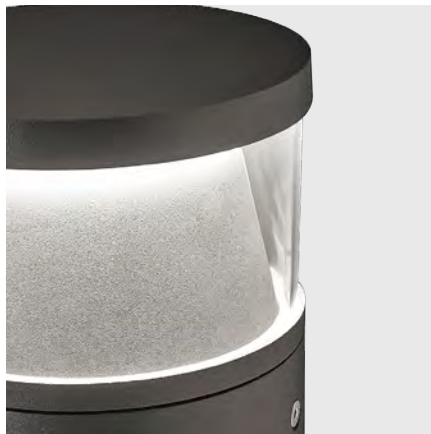

4000 K

Dan 450mm

BODY MAT
AL

DIF MAT
PC



3
MacAdam

IP
66

IK
10

SWITCH CCT
3000-4000

SEA SIDE SUITABLE

PRO-BASE



Z5 J6

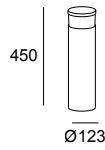

LED						
K	CRI	W Total	Real Lm	Code		
3000-4000	80	11.2	439	55-E019 - Z5 - J6 - EH	ON-OFF 100-240V	

The indicated flux corresponds to 4000K.
Le flux indiqué correspond à 4000K.

Dan 700mm

BODY MAT
AL

DIF MAT
PC



3
MacAdam

IP
66

IK
10

SWITCH CCT
3000-4000

SEA SIDE SUITABLE

PRO-BASE



Z5 J6

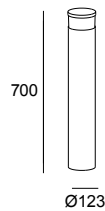

LED						
K	CRI	W Total	Real Lm	Code		
3000-4000	80	11.2	439	55-E012 - Z5 - J6 - EH	ON-OFF 100-240V	

The indicated flux corresponds to 4000K.
Le flux indiqué correspond à 4000K.

Optical accessories Accessoires optiques



Rear light shutter
Obturbateur de lumière arrière

Included

Fixing accessories Accessoires de fixation



Fixing bolts
Boulons de fixation

71-E092-48-48

Row

Designed by LedsC4 Architectural

Integration in cement architecture Intégration dans l'architecture en ciment

Row is made of 100% metal-reinforced cement, providing total integration into architecture in addition to robustness and durability.

En ciment à 100 %, Row est dotée d'une armature métallique à l'intérieur, ce qui se traduit par une intégration architecturale totale, à laquelle viennent s'ajouter la robustesse et la durabilité.



Row finishes are unique thanks to the use of cement, a noble and artisan material whose irregular surface can vary from piece to piece, making them all one-of-a-kind.

Les finitions de Row sont uniques grâce au ciment, matériau noble et artisanal dont la surface irrégulière peut varier d'une pièce à l'autre, ce qui leur confère un caractère distinctif.

Row 230mm

BODY MAT
CON

DIF MAT
PC



50000h
L80 B20

3
MacAdam

IP
65

IK
10

BREEAM



SEA SIDE
SUITABLE

PRO-BASE



DC



LED

K	CRI	W Total	Real Lm	Code	
3000	80	19.3	1071	10-E053 - DC - CL	ON-OFF 220-240V

Row 500mm

BODY MAT
CON

DIF MAT
PC



50000h
L80 B20

3
MacAdam

IP
65

IK
10

BREEAM



SEA SIDE
SUITABLE

PRO-BASE



DC

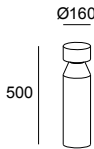

LED

K	CRI	W Total	Real Lm	Code	
3000	80	19.3	1071	55-E053 - DC - CL	ON-OFF 220-240V

Row 900mm

BODY MAT
CON

DIF MAT
PC



50000h
L80 B20

3
MacAdam

IP
65

IK
10

BREEAM



SEA SIDE
SUITABLE

PRO-BASE



DC

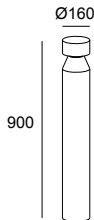

LED

K	CRI	W Total	Real Lm	Code	
3000	80	19.3	1071	55-E056 - DC - CL	ON-OFF 100-277V

Fixing accessories
Accessoires de fixation



Fixing bolts
Boulons de fixation

71-E029-48-48

Simenti

Designed by LedsC4 Architectural

Wall Fixture
P. 819

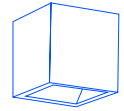

Integration and visual comfort Intégration et confort visuel

The Simenti collection, composed of a bollard and wall light, is made of 100% cement and has been designed to offer high visual comfort, thus becoming an ideal option for integrations in concrete floors for luxury residences.

Composée d'une borne et d'une applique, la collection Simenti est 100 % en ciment et a été conçue pour offrir un confort visuel élevé, ce qui en fait une option idéale pour l'intégration dans les dallages en béton des résidences de standing.

Simenti Bollard

BODY MAT CON	DIF MAT GLA		50000h L80 B20	3 MacAdam	IP 66	IK 8	LOW FLICKER	BREEAM	SEA SIDE SUITABLE		
-----------------	----------------	--	-------------------	--------------	----------	---------	----------------	--------	----------------------	--	--

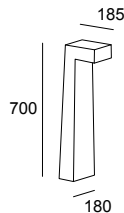

LED						
K	CRI	W Total	Real Lm	Code		
3000	80	11.6	597	55-9971 - DC - CL	ON-OFF	100-240V

Fixing accessories Accessoires de fixation



Fixing bolts
Boulons de fixation

71-E030-48-48

Simenti finishes are unique thanks to the use of cement, a noble and artisan material whose irregular surface can vary from piece to piece, making them all one-of-a-kind.

Les finitions de Simenti sont uniques grâce au ciment, matériau noble et artisanal dont la surface irrégulière peut varier d'une pièce à l'autre, ce qui leur confère un caractère distinctif.



Diago

Designed by LedsC4 Architectural

Wall Fixture
P. 819

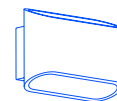

Understated and elegant Discrète et élégante

The Diago bollard features a restrained, compact design, with a low light effect and no light pollution, making it a good choice for residential areas.

Arborant un design sobre et compact allié à un effet de lumière contenu et sans pollution lumineuse, la borne Diago est une bonne option pour les zones résidentielles.

Diago

BODY MAT	DIF MAT		50000h	3	IP	IK	BREEAM	SEA SIDE SUITABLE		
AL	GLA		L80 B20	MacAdam	65	05				

Z5

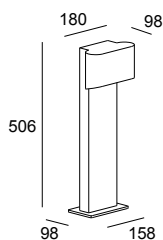

LED						
K	CRI	W Total	Real Lm	Code		
3000	80	6.5	494	55-9873 - Z5 - CL	ON-OFF 100-240V	

Fixing accessories Accessoires de fixation



Fixing bolts
Boulons de fixation

71-E009-48-48



Elegance and solidity Élégance et solidité

The classic rectangular design remains an ideal option for functional projects favouring simple and straight lines. The breadth of the Cubik collection offers a solution for all the needs arising from this type of setting.

Ce design rectangulaire classique reste une option idéale pour les projets fonctionnels aux lignes simples et droites. La variété de la collection Cubik permet de répondre à tous les besoins liés à ce type d'espaces.

Cubik LED 201mm

BODY MAT	DIF MAT		IP	IK	BREEAM	SWITCH CCT	50000h	3	SEA SIDE SUITABLE	PRO-BASE	LED	DRIVER
AL	PC		65	10		2700-3000-4000	L80 B20	MacAdam				

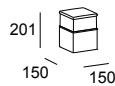

LED

K	CRI	W	Real Lm	Code	
2700-3200-4000	80	15.6	1290	10-9938 - Z5 - EH	ON-OFF 100-240V

The indicated flux corresponds to the core temperature.
Le flux indiqué correspond à la température centrale.

Z5

Cubik LED 650mm

BODY MAT	DIF MAT		IP	IK	BREEAM	SWITCH CCT	50000h	3	SEA SIDE SUITABLE	PRO-BASE	LED	DRIVER
AL	PC		65	10		2700-3000-4000	L80 B20	MacAdam				

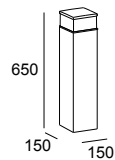

LED

K	CRI	W	Real Lm	Code	
2700-3200-4000	80	15.6	1290	55-9938 - Z5 - EH	ON-OFF 100-240V

The indicated flux corresponds to the core temperature.
Le flux indiqué correspond à la température centrale.

Z5

Cubik LED 1000mm

BODY MAT	DIF MAT		IP	IK	BREEAM	SWITCH CCT	50000h	3	SEA SIDE SUITABLE	PRO-BASE	LED	DRIVER
AL	PC		65	10		2700-3000-4000	L80 B20	MacAdam				

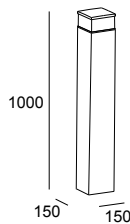

LED

K	CRI	W	Real Lm	Code	
2700-3200-4000	80	15.6	1290	55-9939 - Z5 - EH	ON-OFF 100-240V

The indicated flux corresponds to the core temperature.
Le flux indiqué correspond à la température centrale.

Z5

Fixing accessories Accessoires de fixation



Fixing bolts
Boulons de fixation

71-E002-48-48



**Cubik E27
230mm**

BODY MAT	DIF MAT		IP	IK	SEA SIDE SUITABLE
AL	PC		54	10	

Z5

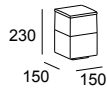

E27	
W	Code
Max. 15	10-9386 - Z5 - M3

**Cubik E27
300mm**

BODY MAT	DIF MAT		IP	IK	SEA SIDE SUITABLE
AL	PC		54	10	

Z5

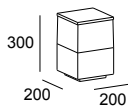

E27	
W	Code
Max. 15	10-9387 - Z5 - M3

**Cubik E27
600mm**

BODY MAT	DIF MAT		IP	IK	SEA SIDE SUITABLE
AL	PC		54	10	

Z5

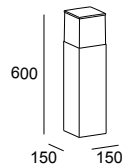

E27	
W	Code
Max. 15	55-9488 - Z5 - M3

**Cubik E27
900mm**

BODY MAT	DIF MAT		IP	IK	SEA SIDE SUITABLE
AL	PC		54	10	

Z5

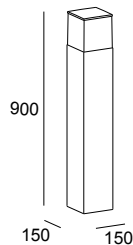

E27	
W	Code
Max. 15	55-9549 - Z5 - M3

Fixing accessories
Accessoires de fixation



Fixing bolts
Boulons de fixation

71-E002-48-48

Priap

Designed by LedsC4 Architectural



Superior quality Qualité supérieure

Made entirely of AISI 316 stainless steel, this luminaire is suitable for installation in environments with adverse weather conditions, such as coastal areas. Its internal reflectors minimise light pollution.

Fabriquée intégralement en acier inoxydable AISI 316, cette borne peut être installée dans des environnements soumis à des conditions météorologiques défavorables, telles que les milieux marins. Ses réflecteurs internes permettent de minimiser la pollution lumineuse.

Priap 500mm

BODY MAT AISI316	DIF MAT PC		IP 54	IK 07	SEA SIDE SUITABLE	PRO-BASE
---------------------	---------------	--	----------	----------	----------------------	----------

CA

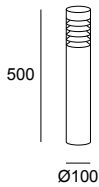

E27

W

Max. 15

Code

55-9239 - CA - M2

Priap 800mm

BODY MAT AISI316	DIF MAT PC		IP 54	IK 07	SEA SIDE SUITABLE	PRO-BASE
---------------------	---------------	--	----------	----------	----------------------	----------

CA

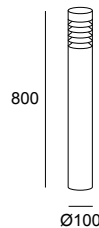

E27

W

Max. 15

Code

55-9440 - CA - M2

Fixing accessories Accessoires de fixation



Fixing bolts
Boulons de fixation

71-E028-48-48



Resistant to constant high humidity Resistente a un'elevata umidità costante

Able to resist the most humid and salinity extreme conditions thanks to its high quality plastic materials and its E-27 lamp holder, as the only electronic component.

Capable de résister aux conditions les plus humides et de salinité extrême grâce à ses matières plastiques de haute qualité et à son Douille E-27, comme seul composant électronique.

Nott E27 500mm

BODY MAT	DIF MAT		IP	IK	SEA SIDE SUITABLE
PP	PC		65	08	

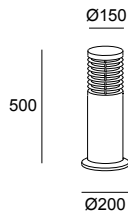
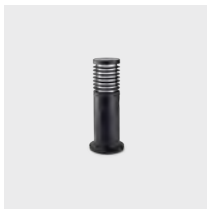

E27

W
Max. 15

Code
55-9655 - 05 - CD

●
05

Nott E27 900mm

BODY MAT	DIF MAT		IP	IK	SEA SIDE SUITABLE
PP	PC		65	08	

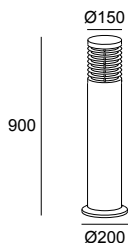

E27

W
Max. 15

Code
55-9656 - 05 - CD

●
05

Fixing accessories Accessoires de fixation



Fixing bolts
Boulons de fixation

71-E018-48-48

Grid

Designed by LedsC4 Architectural

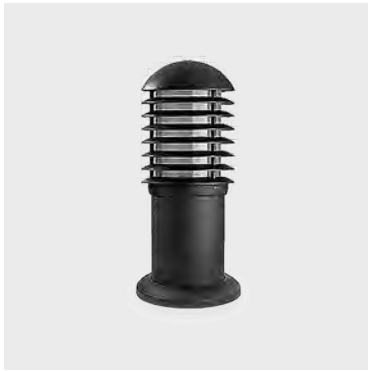

A revamped classic Classique révisité

A classic residential collection with an E-27 light source and robust appearance softened by rounded shapes. Resistant in harsh coastal conditions.
Collection classique à usage résidentiel avec source lumineuse E-27 et un aspect robuste adouci par des formes arrondies. Résistant en milieu marin.

Grid 300mm

BODY MAT	DIF MAT		IP	IK	SEA SIDE SUITABLE
AL	PC		44	08	

●
Z5

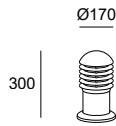
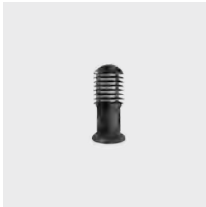

E27	Code
W Max. 15	55-9318 - Z5 - M3

Grid 500mm

BODY MAT	DIF MAT		IP	IK	SEA SIDE SUITABLE
AL	PC		44	08	

●
Z5

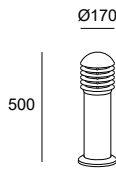
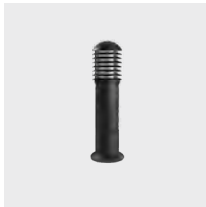

E27	Code
W Max. 15	55-9319 - Z5 - M3

Grid 900mm

BODY MAT	DIF MAT		IP	IK	SEA SIDE SUITABLE
AL	PC		44	08	

●
Z5

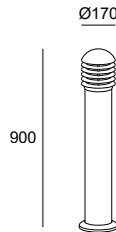
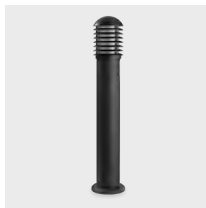

E27	Code
W Max. 15	55-9320 - Z5 - M3

Fixing accessories Accessoires de fixation



Fixing bolts
Boulons de fixation

71-9955-48-48



Personality and robustness Présence et robustesse

Its large dimensions, powerful output and 360° emission make this collection ideal for large spaces within big buildings. Citizen has a high dissipation capacity, providing superior energy efficiency. Grandes dimensions, puissance exceptionnelle et émission à 360° sont autant d'atouts qui rendent cette collection très adaptée aux vastes espaces et aux grands bâtiments. Citizen arbore une grande capacité de dissipation, ce qui se traduit par une haute efficacité énergétique.

Citizen LED

BODY MAT ST	DIF MAT PC	IP 65	IK 10	UGR <19		50000h L80 B20	2 MacAdam	SEA SIDE SUITABLE			
----------------	---------------	----------	----------	------------	--	-------------------	--------------	----------------------	--	--	--

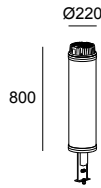
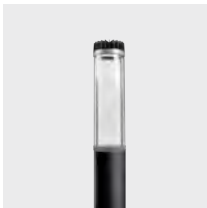

LED						
K	CRI	W Total	Real Lm	Code		
3000	80	59	4257	60-3239 - Z5 - CL	1-10V 100-240V	

Z5

Citizen Structure

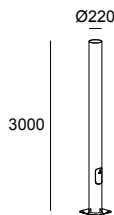

Code
81-3239 - Z5 - Z5

Z5

Fixing accessories Accessoires de fixation



Access door key
Clé de porte d'entrée

Included



Bolts and template
Boulons et gabarit

Included

Repair accessories Accessoires de réparation



Z5 anti-scratch paint
Peinture Z5 anti-rayures

71-E117-Z5-00

Proud

Designed by LedsC4 Architectural



Personality that adapts to the space Une personnalité qui s'adapte à l'espace

The design of the Proud head brings an extra touch of personality to the spaces where it is installed. It can be installed both in transit areas, where the asymmetrical version would be more suitable, and in large areas, where the symmetrical model is recommended.

Le design de la tête Proud apporte une touche de personnalité aux espaces qui l'accueillent. On peut installer ce modèle aussi bien dans les zones de passage, où la version asymétrique est conseillée, que dans les grands espaces, plus adaptés au modèle symétrique.

Proud Symmetrical

IP 66	IK 10	DIF MAT PC	LOW FLICKER		BREEAM	50000h L80 B20	3 MacAdam		0.4 m			
----------	----------	---------------	----------------	--	--------	-------------------	--------------	--	-------	--	--	--

Z5

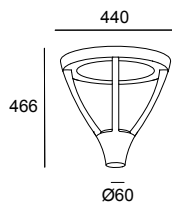

LED						
K	CRI	W Total	Real Lm	Code		
3000	80	44.9	3110	60-9913	- Z5 - CL	ON-OFF 100-240V
3000	80	85.4	5223	60-9996		
4000	80	44.9	3110	60-9913	- Z5 - CM	ON-OFF 100-240V
4000	80	85.4	5695	60-9996		

Proud Asymmetrical

IP 66	IK 10	DIF MAT PC		BREEAM	50000h L80 B20	3 MacAdam		0.4 m			
----------	----------	---------------	--	--------	-------------------	--------------	--	-------	--	--	--

Z5

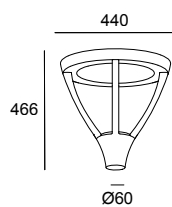
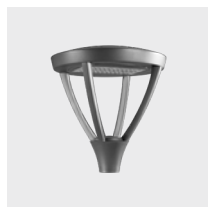

LED						
K	CRI	W Total	Real Lm	Code		
3000	80	46.4	4879	60-E082	- Z5 - CL	ON-OFF 100-277V
4000	80	46.4	5227	60-E082		
					- Z5 - CM	ON-OFF 100-277V

Proud Structure

BODY MAT

AL

SEA SIDE

SUITABLE

Z5

OUTDOOR

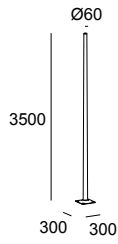

Code

81-E000 - Z5 - Z5

Fixing accessories

Accessoires de fixation



Fixing bolts
Boulons de fixation

71-E213-48-48

Repair accessories

Accessoires de réparation



Z5 anti-scratch paint
Peinture Z5 anti-rayures

71-E117-Z5-00

Zigzag

Designed by Luca Turrini



+ Zigzag

Architectural design Design architectural

Zigzag's elegant, straight, contemporary design is an ideal choice for settings such as museums, shopping centres and universities as it enhances the architecture where it is located. The design and lighting quality of this collection live up to the most discerning expectations.

Le design élégant, rectiligne et contemporain de Zigzag est un choix idéal pour les architectures telles que celle des musées, centres commerciaux ou universités, car il sublime l'environnement dans lequel il se trouve. Le design et la qualité d'éclairage de cette collection répondent aux attentes les plus exigeantes.



3000 mm

3650 mm

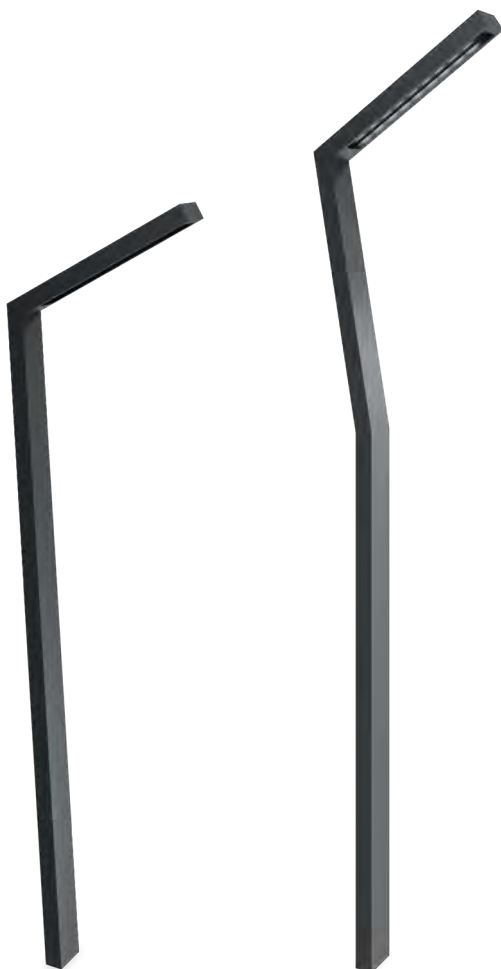

Asymmetrical lenses
Lentilles asymétriques



Symmetrical optics
Optiques symétriques

Zig-Zag Symmetrical

BODY MAT	IP	IK	DIF MAT	LOW		BREEAM	50000h	3					SEA SIDE SUITABLE
AL	65	03	GLA	FLICKER			L80 B20	MacAdam	2.7 m				

Z5

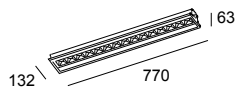

LED						
K	CRI	W Total	Real Lm	Optics	Code	
3000	80	63.4	4264	51°	60-E102 - Z5 - CL	1-10V 100-120V

Zig-Zag Asymmetrical

BODY MAT	IP	IK	DIF MAT	LOW		BREEAM	50000h	3					SEA SIDE SUITABLE
AL	65	03	GLA	FLICKER			L80 B20	MacAdam	2.7 m				

Z5

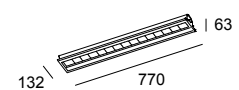

LED						
K	CRI	W Total	Real Lm	Optics	Code	
3000	80	62.1	5595	104°	60-E000 - Z5 - CL	0-10V 100-240V

Zig-Zag 3000mm Structure

BODY MAT	SEA SIDE SUITABLE
AL	

Z5

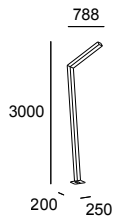

Code
81-E102 - Z5 - Z5

Zig-Zag 3650mm Structure

BODY MAT	SEA SIDE SUITABLE
AL	

Z5

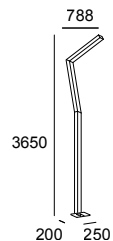

Code
81-E103 - Z5 - Z5

Repair accessories Accessoires de réparation



Z5 anti-scratch paint
Peinture Z5 anti-rayures

71-E117-Z5-00

Wall Fixtures Appliques

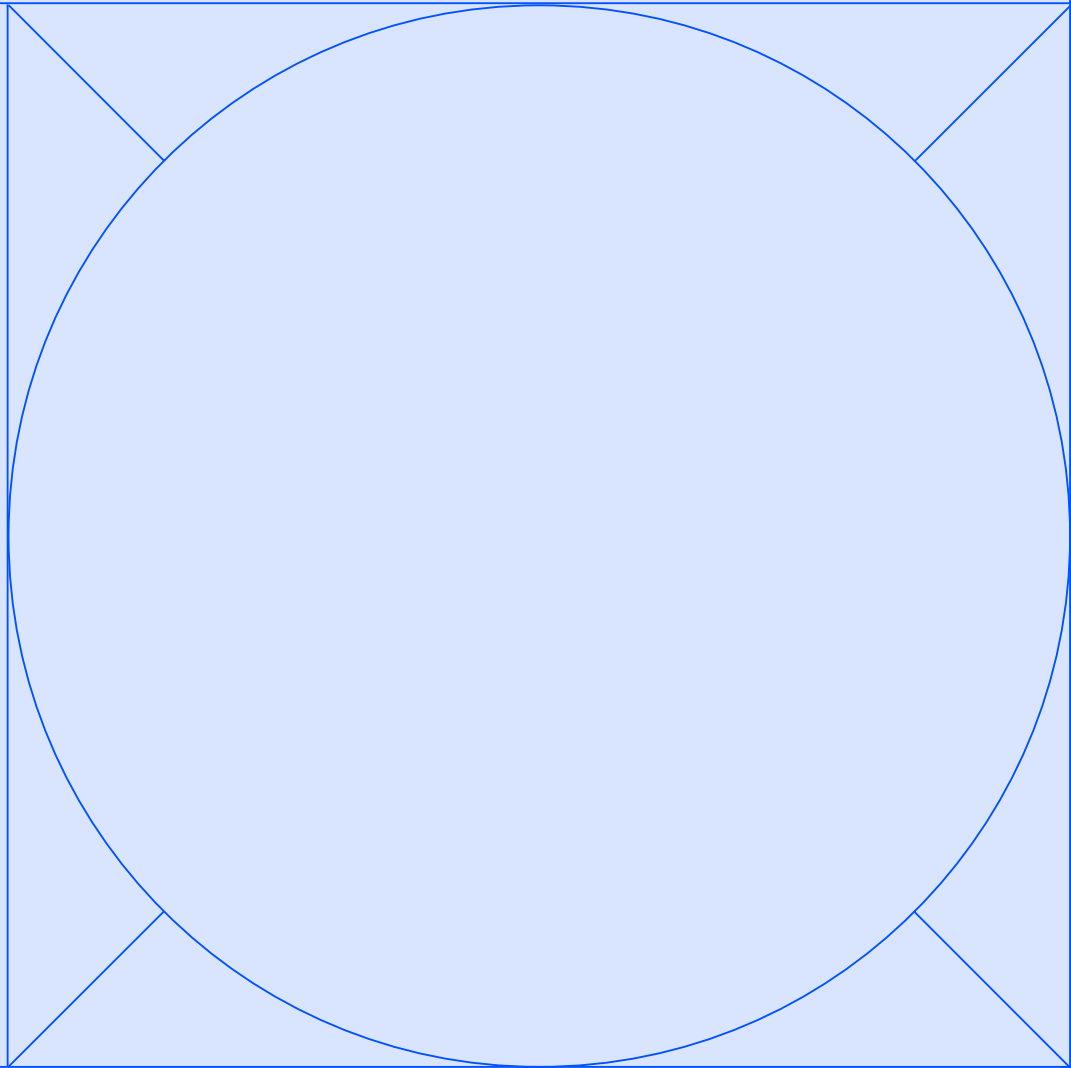

Modis

782

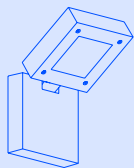

Max

788

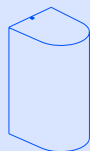

Eko

794



Cosmos

798

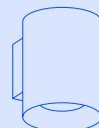

Afrodita

802

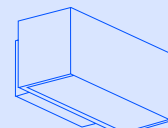

Nemesis

814

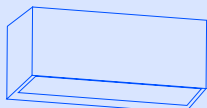

Wilson

816

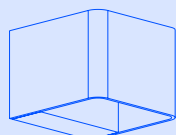

Clous

818

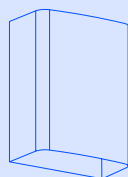

Simenti

819

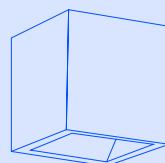

Diago

819

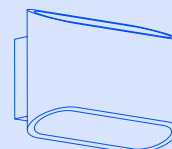

Finestra

820



Rack

823

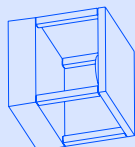

Moal

826



Arc

828

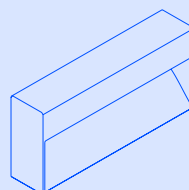

Sam

830

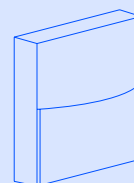

Kössel

834



Skat

837



Curie

841

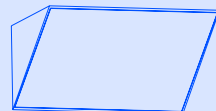

Darwin

844

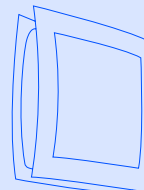

Basic

845



Modis

Designed by Luca Turrini



+ Modis

Spotlight
P. 553



Bollard
P. 706

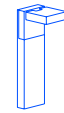

Lamppost
P. 706



Ceiling
P. 862



Versatility and movement Polyvalence et mouvement

The Modis wall light is the ideal choice for spaces requiring extra versatility and lighting adapted to the environment. Both its movable heads and the different extensions available for the structure, as well as the choice of lenses, make it the ideal option for elaborate architecture.

L'applique Modis est l'option idéale pour les espaces qui nécessitent un plus de polyvalence et d'adaptation de l'éclairage à l'environnement. Tant ses têtes mobiles que les différentes extensions de la structure et la possibilité de choisir l'optique en font le choix idéal pour les architectures soucieuses du détail.

Opal



Optics



14

34

DL

E3

J6

Z5

60





Modis

Wall, Ceiling & Spotlight

BODY MAT	DIF MAT		50000h	3
AL	GLA		L80 B20	MacAdam

Modis Opal Single

IP	IK	SWITCH CCT		SEA SIDE SUITABLE				
66	10	2700-3200-4000						

Z5 14* 60* 34* J6* E3* DL*

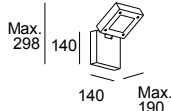

LED					
K	CRI	W Total	Real Lm	Code	
				Z5	
				J6	
				E3	OU ON-OFF 100-277V
2700-3200-4000	80	13.2	744	05-E062 - DL - DU	DALI-2 100-277V
				14	XB CASAMBI 220-240V ⚡
				60	
				34	

The indicated flux corresponds to the core temperature.
Le flux indiqué correspond à la température centrale.

Modis Opal Double 430mm

IP	IK	BREEAM	SWITCH CCT		SEA SIDE SUITABLE				
66	10		2700-3200-4000						

Z5 14* 60* 34* J6* E3* DL*

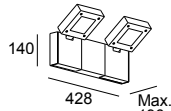

LED					
K	CRI	W Total	Real Lm	Code	
				Z5	
				J6	
				E3	OU ON-OFF 100-277V
2700-3200-4000	80	2 × 26.4	1488	05-E063 - DL - DU	DALI-2 100-277V
				14	XB CASAMBI 220-240V ⚡
				60	
				34	

The indicated flux corresponds to the core temperature.
Le flux indiqué correspond à la température centrale.

Modis Opal Double 800mm

IP	IK	BREEAM	SWITCH CCT		SEA SIDE SUITABLE				
66	10		2700-3200-4000						

Z5 14* 60* 34* J6* E3* DL*

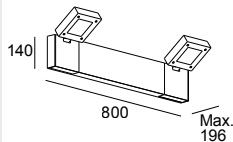

LED					
K	CRI	W Total	Real Lm	Code	
				Z5	
				J6	
				E3	OU ON-OFF 100-277V
2700-3200-4000	80	2 × 26.4	1488	05-E064 - DL - DU	DALI-2 100-277V
				14	XB CASAMBI 220-240V ⚡
				60	
				34	

The indicated flux corresponds to the core temperature.
Le flux indiqué correspond à la température centrale.

Modis Optics Simple



Code example / Exemple d'élaboration d'une référence: **AS11-18V9S30UZ5**

Model	W	K	CRI	Real Lm	Optics	Source	Finishes	
AS11 - Single ↻350° ↻180° 	18P8	18.3	2200	80	932-1062	S3 16°	OU ON-OFF 220-240V	Z5
	18V9	18.3	2700	90	1680-1914	M3 38°	DS DALI-2/PUSH 220-240V	14*
	18W9	18.3	3000	90	1680-1914	F1 48°	XB CASAMBI 220-240V	60*
	18X9	18.3	4000	90	1826-2080			34*
							J6*	
							E3*	
							DL*	

Modis Optics Double 430mm



Code example / Exemple d'élaboration d'une référence: **AS12-37V9S30UZ5**

Model	W	K	CRI	Real Lm	Optics	Source	Finishes	
AS12 - Double 430mm ↻350° ↻180° 	37P8	2 × 18.3	2200	80	1864-3652	S3 16°	OU ON-OFF 220-240V	Z5
	37V9	2 × 18.3	2700	90	3360-3828	M3 38°	DS DALI-2/PUSH 220-240V	14*
	37W9	2 × 18.3	3000	90	3360-3828	F1 48°	XB CASAMBI 220-240V	60*
	37X9	2 × 18.3	4000	90	3652-4160			34*
							J6*	
							E3*	
							DL*	

Modis Optics Double 800mm



Code example / Exemple d'élaboration d'une référence: **AS13-37V9S30UZ5**

Model	W	K	CRI	Real Lm	Optics	Source	Finishes	
AS13 - Double 800mm ↻350° ↻180° 	37P8	2 × 18.3	2200	80	1864-3652	S3 16°	OU ON-OFF 220-240V	Z5
	37V9	2 × 18.3	2700	90	3360-3828	M3 38°	DS DALI-2/PUSH 220-240V	14*
	37W9	2 × 18.3	3000	90	3360-3828	F1 48°	XB CASAMBI 220-240V	60*
	37X9	2 × 18.3	4000	90	3652-4160			34*
							J6*	
							E3*	
							DL*	

* Please contact our sales team for conditions and delivery times.

* Consultez notre équipe commerciale pour connaître les conditions et les délais de livraison.

Lens accessories**Accessoires optiques**Visor
Visière

Z5 ●	71-E234-Z5-00	14 ○*	71-E234-14-00
J6 ●*	71-E234-J6-00	60 ●*	71-E234-60-00
E3 ●*	71-E234-E3-00	34 ○*	71-E234-34-00
DL ○*	71-E234-DL-00		

Fixing accessories**Accessoires de fixation**235mm spiked post
Piquet de 235 mm
Only for single

-

71-9997-05-05**Joint accessories****Accessoires de raccord**Interlinking plate
Plaque d'enchaînement
Not for single

Z5 ●	71-E235-Z5-00	14 ○*	71-E235-14-00
J6 ●*	71-E235-J6-00	60 ●*	71-E235-60-00
E3 ●*	71-E235-E3-00	34 ○*	71-E235-34-00
DL ○*	71-E235-DL-00		



Max

Designed by LedsC4 Architectural



+ Max

Downlight
P. 598



Uplight
P. 630



Bollard
P. 738



Ceiling
P. 852



Spotlight
P. 540



The best of interior design applied to the outdoors Le meilleur du design d'intérieur appliqué à l'extérieur

Max wall lights are a great choice for projects requiring a single family of luminaires for both indoor and outdoor use. Thanks to a design with concealed screws, its wide range of options and advanced features, it easily adapts to the most challenging projects.

Les appliques Max sont particulièrement adaptées aux projets où une seule famille de luminaires est nécessaire pour l'intérieur et l'extérieur. Grâce à sa conception à vis invisibles, à sa large gamme d'options et à ses hautes prestations, ce modèle s'adapte facilement aux projets les plus exigeants.

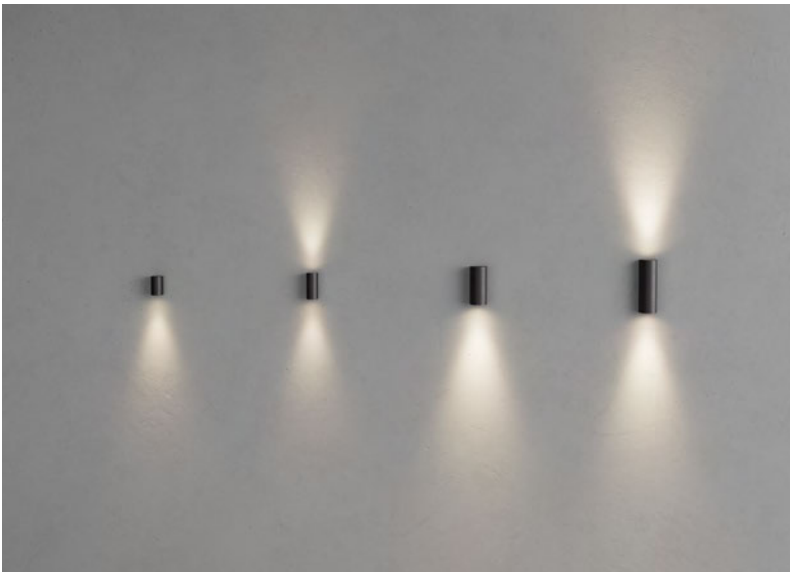

14

34

DL

E3

J6

Z5

60





2200K

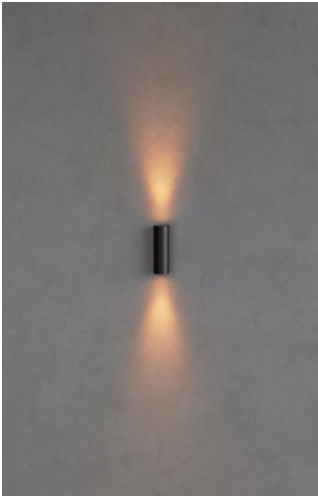

2700K

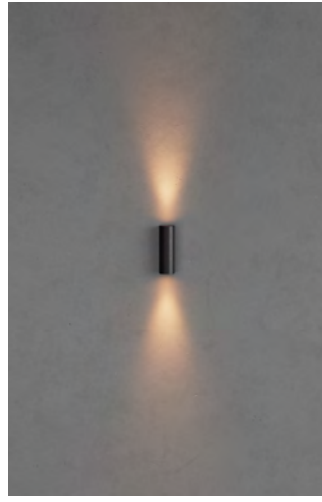

3000K



4000K



Available in 2200 K, a temperature that is more eco-friendly for the local plant and animal life.

Disponible en 2200 K, température plus respectueuse de la faune et la flore environnantes.



Max Medium Wall Fixture Single Emission

BODY MAT
AL

DIF MAT
GLA



50000h
L80 B20

2
MacAdam

IP
66/67

IK
10

SEA SIDE
SUITABLE



Code example / Exemple d'élaboration d'une référence: **AI19-P4V9S10SZ5**

Model		W	K	CRI	Optics	Real Lm	Source	Finishes
AI19 - Single Emission 100mm 	P4V9	4	2700	90	S1 9°	286	OS ON-OFF 220-240V	14*
	P4W9	4	3000	90				34*
	P4X9	4	4000	90				60*
	P7P8	6.5	2200	80	S2 17°	519	OS ON-OFF 220-240V	DL*
	P7V9	6.5	2700	90	M2 27°	459		E3*
	P7W9	6.5	3000	90	F1 50°	423		J6*
	P7X9	6.5	4000	90				Z5
AI23 - Single Emission 204mm 	P6V9	6	2700	90	S1 9°	373	DU DALI-2 100-277V	
	P6W9	6	3000	90				
	P6X9	6	4000	90				
	P8P8	8.9	2200	80	S2 17°	610	DU DALI-2 100-277V	
	P8V9	8.9	2700	90	M2 27°	540		
	P8W9	8.9	3000	90	F1 50°	498		
	P8X9	8.9	4000	90				

Max Big Wall Fixture Single Emission

BODY MAT
AL

DIF MAT
GLA



50000h
L80 B20

2
MacAdam

IP
66

IK
10



Code example / Exemple d'élaboration d'une référence: **AT19-18V9S30SZ5**

Model		W	K	CRI	Optics	Real Lm	Source	Finishes
AT19 - Single Emission 200mm 	13V9	13.7	2700	90	S1 10°	1054	OS ON-OFF 36V/max.350mA	14*
	13W9	13.7	3000	90			DU DALI-2 36V/max.350mA	34*
	13X9	13.7	4000	90				60*
	18P8	17.3	2200	80	S3 21°	2135	OS ON-OFF 220-240V	DL*
	18V9	17.3	2700	90	M3 31°	2203	DU DALI-2 100-277V	E3*
	18W9	17.3	3000	90	F1 40°	1812		J6*
	18X9	17.3	4000	90				Z5

* Please contact our sales team for conditions and delivery times.

* Consultez notre équipe commerciale pour connaître les conditions et les délais de livraison.

**Max Medium
Wall Fixture
Double Emission**

BODY MAT
AL

DIF MAT
GLA



50000h
L80 B20

2
MacAdam

IP
66

IK
10

LOW
FLICKER

SEA SIDE SUITABLE



Code example / Exemple d'élaboration d'une référence: **AI21-P8V9S10SZ5**

Model		W	K	CRI	Optics	Real Lm	Source	Finishes
AI21 - Double Emission 135mm 	P8V9	8	2700	90	S1 9° + 9°	572	OS ON-OFF 220-240V	14*
	P8W9	8	3000	90				34*
	P8X9	8	4000	90				60*
								DL*
								E3*
	11V9	10.5	2700	90	S7 9° + 17°	805	OS ON-OFF 220-240V	J6*
	11W9	10.5	3000	90	S8 9° + 27°	745		Z5
	11X9	10.5	4000	90	S9 9° + 50°	709		
	13P8	13	2200	80	F1 50° + 50°	846	OS ON-OFF 220-240V	
	13V9	13	2700	90	M2 27° + 27°	918		
	13W9	13	3000	90	M5 27° + 50°	882		
	13X9	13	4000	90	S2 17° + 17°	1038		
				S5 17° + 27°	978			
				S6 17° + 50°	942			
AI24 - Double Emission 245mm 	12V9	12	2700	90	S1 9° + 9°	747	DU DALI-2 100-277V	
	12W9	12	3000	90				
	12X9	12	4000	90				
	14V9	14.1	2700	90	S7 9° + 17°	957	DU DALI-2 100-277V	
	14W9	14.1	3000	90	S8 9° + 27°	887		
	14X9	14.1	4000	90	S9 9° + 50°	844		
	17P8	17.8	2200	80	F1 50° + 50°	996	DU DALI-2 100-277V	
	17V9	17.8	2700	90	M2 27° + 27°	1080		
	17W9	17.8	3000	90	M5 27° + 50°	1038		
	17X9	17.8	4000	90	S2 17° + 17°	1220		
					S5 17° + 27°	1150		
					S6 17° + 50°	1108		

* Please contact our sales team for conditions and delivery times.

* Consultez notre équipe commerciale pour connaître les conditions et les délais de livraison.

Max Big Wall Fixture Double Emission

BODY MAT
AL

DIF MAT
GLA



50000h
L80 B20

2
MacAdam

IP
66/67

IK
10

BREEAM



SEA SIDE
SUITABLE



Code example / Exemple d'élaboration d'une référence: **AT21-33V9S30SZ5**

Model	W	K	CRI	Optics	Real Lm	Source	Finishes	
AT21 - Double Emission 280mm 	27V9	27.4	2700	90	S1 10° + 10°	2108	OS ON-OFF 220-240V	14* 34* 60* DL* E3* J6* Z5
	27W9	27.4	3000	90	S7 10° + 21°	2755	DU DALI-2 100-277V	
	27X9	27.4	4000	90	S8 10° + 31°	2807		
					S9 10° + 40°	2496		
	33P8	31.5	2200	80	M3 31° + 31°	4406	OS ON-OFF 220-240V	
	33V9	31.5	2700	90	M5 31° + 39°	4015	DU DALI-2 100-277V	
	33W9	31.5	3000	90	F1 39° + 39°	3624		
	33X9	31.5	4000	90	S3 21° + 21°	4270		
					S5 21° + 31°	4338		
					S6 21° + 39°	3947		

* Please contact our sales team for conditions and delivery times.
 * Consultez notre équipe commerciale pour connaître les conditions et les délais de livraison.

Max Medium



Max Big



Lens accessories Accessoires optiques

	Wall washer diffuser (5u.) Diffuseur lèche-mur (5 u.)	71-E463-00-00	71-E464-00-00
	Honeycomb panel (5u.) Grille en nid d'abeille (5 u.)	71-E131-00-00	71-E263-00-00
	Square diffuser (5u.) Diffuseur carré (5 u.)	71-E135-00-00	71-E262-00-00
	Elliptical diffuser (5u.) Diffuseur elliptique (5 u.)	71-E141-00-00	71-E261-00-00
	Opal diffuser (5u.) Diffuseur opalin (5 u.)	71-E133-00-00	71-E260-00-00

Eko

Designed by LedsC4 Architectural



Spotlight
P. 550



Downlight
P. 608



Bollard
P. 744



Ceiling
P. 856



Essential solution for illuminating walls and passageways Solution essentielle pour éclairer murs et zones de passage

Eko wall lights are especially suitable for projects requiring luminaires with a clean and compact design that can easily integrate into architecture. This collection, which includes single-dual emission wall lights and a model especially designed for passageways, stands out for its easy maintenance and affordable price.

Les appliques Eko sont particulièrement adaptées aux projets qui nécessitent des luminaires au design épuré et compact capables de fondre facilement dans l'architecture ambiante. Comprenant des appliques à simple et double émission ainsi qu'un modèle spécialement conçu pour les zones de transit, cette collection se distingue par sa facilité d'entretien et son prix abordable.

Single emission



Single emission Inclined



Double emission



14



34



DL



E3



J6

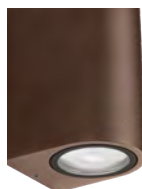

Z5



60



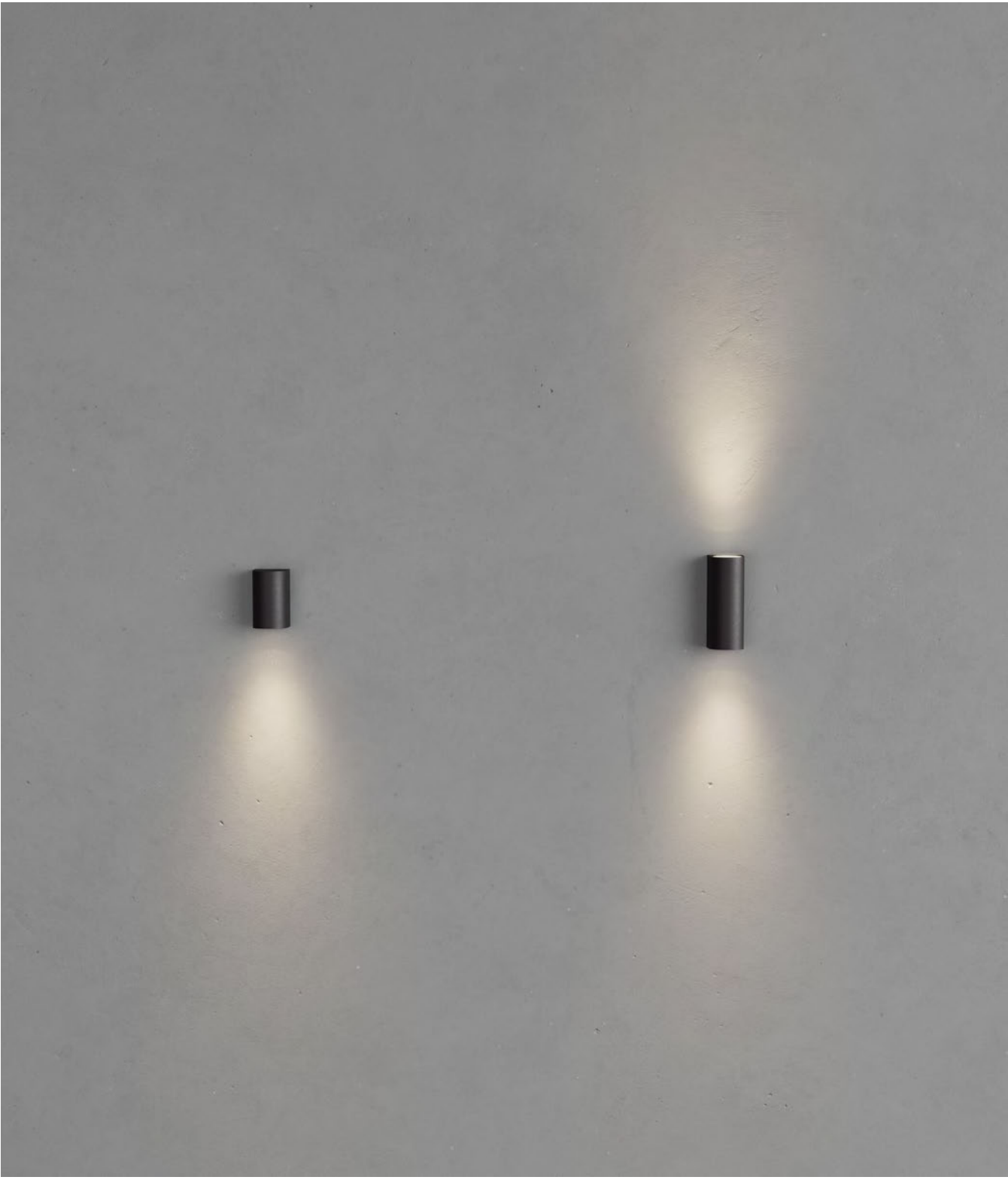

2-second bulb replacement system Système de changement de lampes en 2 secondes

Ultra-fast bulb replacement during maintenance thanks to an optional accessory.
Changement ultra-rapide des ampoules lors de l'entretien grâce à un accessoire en option.

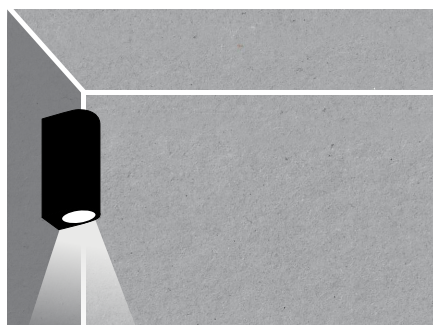
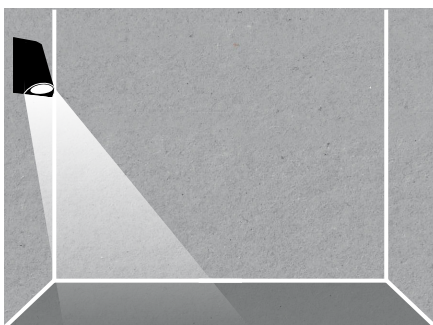

Illumination for transit
areas
Éclairage dans les
zones de passage

Eko Wall Fixture Single Emission

IP	IK	BODY MAT	DIF MAT	
66	07	AL	PC	

60 Z5* 14* 34* J6* E3* DL*

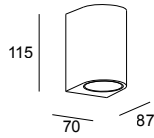

GU10	
W	Code
	60
	Z5
	J6
Max. 8	05-E157 - E3 - 37
	DL
	14
	34



Eko Wall Fixture Double Emission

IP	IK	BODY MAT	DIF MAT	
66	07	AL	PC	

60 Z5* 14* 34* J6* E3* DL*

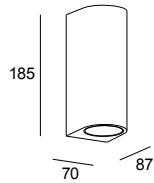

GU10	
W	Code
	60
	Z5
	J6
Max. 2x8	05-E159 - E3 - 37
	DL
	14
	34



Eko Wall Fixture Inclined

IP	IK	BODY MAT	DIF MAT	
66	07	AL	PC	

60 Z5* 14* 34* J6* E3* DL*

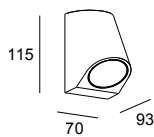

GU10	
W	Code
	60
	Z5
	J6
Max. 8	05-E158 - E3 - 37
	DL
	14
	34

Repair accessories Accessoires de réparation



Bulb extraction kit (suction cup + clamp)
Kit d'extraction de l'ampoule (ventouse + pince)

71-E634-00-00

* Please contact our sales team for conditions and delivery times.
* Consultez notre équipe commerciale pour connaître les conditions et les délais de livraison.

Cosmos

Designed by LedsC4 Architectural

Ceiling
P. 858



Elegant and versatile Élégante et polyvalente

The Cosmos collection has been designed in line with the deco-tech concept and its purpose is to illuminate the façades of hotels, public areas and residences, lending them a decorative touch. The hidden hardware and accessories included make this a highly versatile collection, thanks in part to its models with single and dual emission.

Conçue sous le concept « déco-tech », la collection Cosmos vise à éclairer de façon professionnelle les façades d'hôtels, d'espaces publics et de résidences, en apportant une touche décorative. La visserie invisible et les accessoires inclus en font une famille très utilisée pour sa grande polyvalence, notamment grâce à ses modèles mono et double émission.



**Cosmos Wall Fixture
Single Emission
Small (Ø85mm)**

BODY MAT	DIF MAT		50000h	3	IP	IK	BREEAM	LED	DRIVER
AL	GLA		L80 B20	MacAdam	66	06			

● ● ● ● ● ● ● ●
Z5 *14 *60 *34 *J6 *E3 *DL

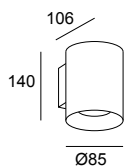

LED						
K	CRI	W Total	Real Lm	Optics	Code	
						Z5
						J6
2700			972			E3 CK
3000	80	12.7	760	17°;31°	05-9952 - DL - CL	ON-OFF 100-240V
4000			819			14 CM
						60
						34

**Cosmos Wall Fixture
Single Emission
Medium (Ø110mm)**

BODY MAT	DIF MAT		50000h	3	IP	IK	BREEAM	LED	DRIVER
AL	GLA		L80 B20	MacAdam	66	06			

● ● ● ● ● ● ● ●
Z5 *14 *60 *34 *J6 *E3 *DL

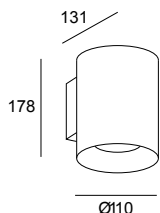

LED						
K	CRI	W Total	Real Lm	Optics	Code	
						Z5
						J6
2700			1696			E3 CK
3000	80	25.4	1823	16°;34°	05-9954 - DL - CL	ON-OFF 100-240V
4000			1823			14 CM
						60
						34

**Cosmos Wall Fixture
Single Emission
Big (Ø144mm)**

BODY MAT	DIF MAT		50000h	3	IP	IK	BREEAM	LED	DRIVER
AL	GLA		L80 B20	MacAdam	66	07			

● ● ● ● ● ● ● ●
Z5 *14 *60 *34 *J6 *E3 *DL

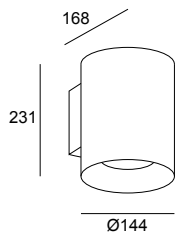

LED						
K	CRI	W Total	Real Lm	Optics	Code	
						Z5
						J6
2700			2890			E3 CK
3000	80	36	2890	16°;34°	05-E150 - DL - CL	ON-OFF 100-240V
4000			3095			14 CM
						60
						34

**Cosmos Wall Fixture
Single Emission
Big (Ø144mm)
DALI-2**

BODY MAT	DIF MAT		50000h	3	IP	IK	BREEAM	LED	DRIVER
AL	GLA		L80 B20	MacAdam	66	07			

● ● ● ● ● ● ● ●
Z5 *14 *60 *34 *J6 *E3 *DL

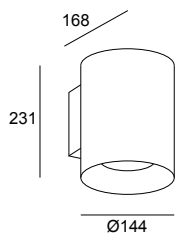

LED						
K	CRI	W Total	Real Lm	Optics	Code	
						Z5
						J6
2700			2890			E3 CK
3000	80	36	2890	16°;34°	05-E148 - DL - CL	DALI-2 120-240V
4000			3095			14 CM
						60
						34

**Cosmos Wall Fixture
Double Emission
Small (Ø85mm)**

BODY MAT	DIF MAT		50000h	3	IP	IK	BREEAM		
AL	GLA		L80 B20	MacAdam	66	06			

● ● ● ● ● ● ● ●
Z5 *14 *60 *34 *J6 *E3 *DL

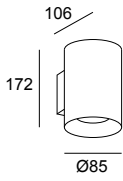

LED										
K	CRI	W Total	Real Lm	Optics	Code					
						Z5				
						J6				
2700			1115			E3	CK			
3000	80	11.8	625	17°;31°	05-9953	- DL	- CL	ON-OFF	100-240V	
4000			960			14	CM			
						60				
						34				

**Cosmos Wall Fixture
Double Emission
Medium (Ø110mm)**

BODY MAT	DIF MAT		50000h	3	IP	IK	BREEAM		
AL	GLA		L80 B20	MacAdam	66	06			

● ● ● ● ● ● ● ●
Z5 *14 *60 *34 *J6 *E3 *DL

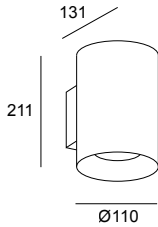

LED										
K	CRI	W Total	Real Lm	Optics	Code					
						Z5				
						J6				
2700			1939			E3				
3000	80	24.5	1823	16°;34°	05-9955	- DL	- CK	ON-OFF	100-240V	
4000			1823			14				
						60				
						34				

**Cosmos Wall Fixture
Double Emission
Big (Ø144mm)**

BODY MAT	DIF MAT		50000h	3	IP	IK	BREEAM		
AL	GLA		L80 B20	MacAdam	66	07			

● ● ● ● ● ● ● ●
Z5 *14 *60 *34 *J6 *E3 *DL

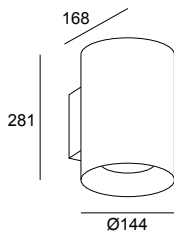

LED										
K	CRI	W Total	Real Lm	Optics	Code					
						Z5				
						J6				
2700						E3	CK			
3000	80	35	3434	16°;34°	05-E151	- DL	- CL	ON-OFF	220-240V	
4000						14	CM			
						60				
						34				

* Please contact our sales team for conditions and delivery times.
* Consultez notre équipe commerciale pour connaître les conditions et les délais de livraison.

Cosmos Wall Fixture
Double Emission
Big (Ø144mm)
DALI-2

BODY MAT
AL

DIF MAT
GLA



50000h
L80 B20

3
MacAdam

IP
66

IK
07

BREEAM



● ● ● ● ● ● ● ●
 Z5 *14 *60 *34 *J6 *E3 *DL

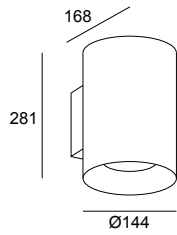

LED						
K	CRI	W Total	Real Lm	Optics	Code	
2700						Z5 J6
3000	80	35	3434	16°;34°	05-E149	E3 CK - DL - CL DALI-2 120-240V
4000						14 CM 60 34

OUTDOOR

Lens accessories
Accessoires optiques

Cosmos
Ø85

Cosmos
Ø110 / Ø144



Set of 2 reflectors (16° and 34°)
 Set de 2 réflecteurs (16° et 34°)

-

Included

Set of 2 reflectors (17° and 31°)
 Set de 2 réflecteurs (17° et 31°)

Included

-

Decorative accessories
Accessoires décoratifs



Set of 2 decoreflectors (silver and gold)
 Set de 2 décoréflecteurs (argent et doré)

-

Included

* Please contact our sales team for conditions and delivery times.
 * Consultez notre équipe commerciale pour connaître les conditions et les délais de livraison.

WALL FIXTURES | APPLIQUES

Afrodita

Designed by LedsC4 Architectural

GU10 Ceiling
P. 868

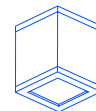

+ Afrodita

Iconic collection of outdoor
wall lights
Emblématique collection
d'appliques d'extérieur



Afrodita Infinite
804

Architectural
integration
Intégration
architecturale

Afrodita Tech
806

Light effects
Effets de lumière

Afrodita LED
808

General light
Éclairage général

Afrodita Power LED
810

Vertical light
Éclairage vertical

Afrodita GU10
812

Use with bulb
Utilisation avec
ampoule

Mono emission

1000 × 105 mm



120 × 120 mm



220 × 90 mm

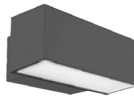

100 × 135 mm



83 × 115 mm



215 × 215 mm



300 × 120 mm

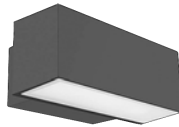

100 × 150 mm



Double emission

1000 × 105 mm



120 × 120 mm



220 × 90 mm

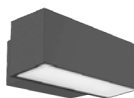

100 × 135 mm



215 × 215 mm



300 × 120 mm

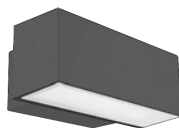

100 × 150 mm



83 × 208 mm



20.3 - 29 W

12 - 37.8 W

11.5 - 39 W
Emergency

10.5 - 17.4 W

1 / 2 x max. 8 W

○ ●
14 Z5

●
Z5

○ ● ●
14 34 Z5

○ ● ● ● ● ● ● ●
14 60 34 DL E3 J6 Z5

○ ● ●
14 34 Z5



F



F



F



M



F

F: Flood (63°-90°) **M:** Medium (22°-26°)

Afrodita Infinite



Easily interlinked with virtually invisible joints
Facile à installer en chaîne avec des raccords pratiquement invisibles

Adjustable lighting Éclairage variable

Choose between single and dual emission and two light beam directions for installation.

Lors de l'installation, une seule référence permet de choisir l'option mono et double émission, ainsi que deux directions du faisceau lumineux.



Interlinking Enchaînement

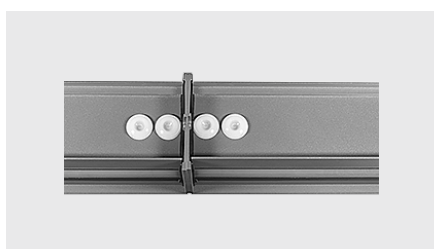

Afrodita Infinite

BODY MAT
AL

DIF MAT
GLA



IP
66

IK
04

LOW
FLICKER

50000h
L80 B20

3
MacAdam



SEA SIDE
SUITABLE

-	+
DIM	

● ○
Z5 14

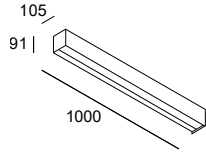

LED									
K	CRI	W Total	Real Lm	Optics	Code				
2700	80	32.5	2083	90°	05-E052	Z5	DALI-2 100-240V	CASAMBI 220-240V	⚡
					05-E086	14			
3000	80	32.5	2083	90°	05-E052	Z5	DALI-2 100-240V	CASAMBI 220-240V	⚡
					05-E086	14			
4000	80	32.5	2083	90°	05-E052	Z5	DALI-2 100-240V	CASAMBI 220-240V	⚡
					05-E086	14			

OUTDOOR

WALL FIXTURES | APPLIQUES

Afrodita Tech



Strong light effects, be they wide or focused, thanks to its accessories
 Effets lumineux marqués, larges ou concentrés, grâce aux accessoires



Focused light accessory included in small models and optional in large models.
 Accessoire d'éclairage concentré fourni dans les modèles de petite dimension et en option dans les grands modèles.

Afrodita Tech Small Single Emission

BODY MAT AL	DIF MAT GLA		IP 65	IK 05	50000h L80 B20	3 MacAdam	SEA SIDE SUITABLE		
----------------	----------------	--	----------	----------	-------------------	--------------	----------------------	--	--

Z5

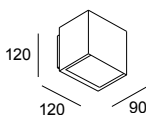

LED							
K	CRI	W Total	Real Lm	Optics	Code		
3000	80	7.1	180	68°	05-E081 - Z5 - CL	ON-OFF	100-277V
4000	80	7.1	180	68°	05-E081 - Z5 - CM	ON-OFF	100-277V



Afrodita Tech Big Single Emission

BODY MAT AL	DIF MAT GLA		IP 66	IK 07	50000h L80 B20	2 MacAdam		SEA SIDE SUITABLE			0-10V
----------------	----------------	--	----------	----------	-------------------	--------------	--	----------------------	--	--	-------

Z5

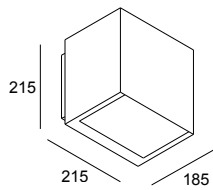

LED							
K	CRI	W Total	Real Lm	Optics	Code		
3000	80	22.3	721	63°	05-E079- Z5 - CL	0-10V 100-240V	
4000	80	22.3	721	63°	05-E079- Z5 - CM	0-10V 100-240V	



Afrodita Tech Small Double Emission

BODY MAT AL	DIF MAT GLA		IP 65	IK 05	50000h L80 B20	3 MacAdam	SEA SIDE SUITABLE		
----------------	----------------	--	----------	----------	-------------------	--------------	----------------------	--	--

Z5

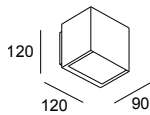

LED							
K	CRI	W Total	Real Lm	Optics	Code		
3000	80	13.9	360	68°	05-E080- Z5 - CL	ON-OFF 100-277V	
4000	80	13.9	360	68°	05-E080- Z5 - CM	ON-OFF 100-277V	



Afrodita Tech Big Double Emission

BODY MAT AL	DIF MAT GLA		IP 66	IK 07	50000h L80 B20	2 MacAdam		SEA SIDE SUITABLE			0-10V
----------------	----------------	--	----------	----------	-------------------	--------------	--	----------------------	--	--	-------

Z5

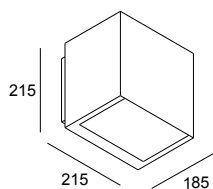

LED							
K	CRI	W Total	Real Lm	Optics	Code		
3000	80	43.7	1441	63°	05-E078- Z5 - CL	0-10V 100-240V	
4000	80	43.7	1441	63°	05-E078- Z5 - CM	0-10V 100-240V	



Afrodita Tech Small Single Emission



Afrodita Tech Big Single Emission



Afrodita Tech Small Double Emission



Afrodita Tech Big Double Emission



Lens accessories Accessoires optiques



Magnifier to create narrow beam of light
Loupe de faisceau lumineux étroit

Included

71-E078-Z5-00

-

-



Lense to create narrow beam of light (2u.)
Loupe de faisceau lumineux étroit (2 u.)

-

-

Included

71-E078-Z5-00

Afrodita Led



The most specified,
the classic Up&down
L'applique la plus spécifique,
le modèle Up&down classique

Smart

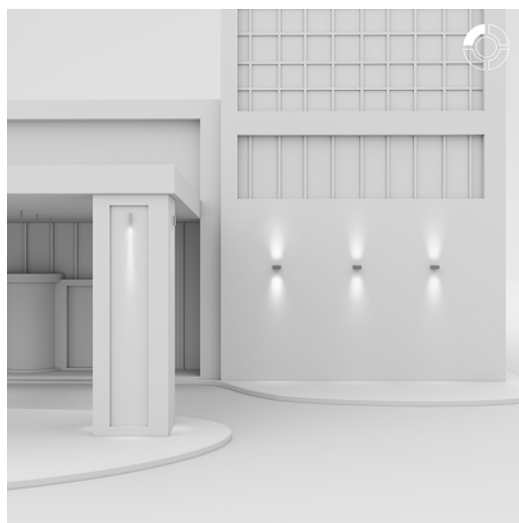

Single and dual emission option
Option mono et double émission

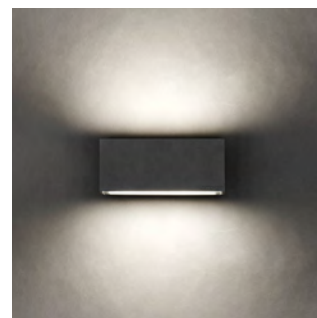
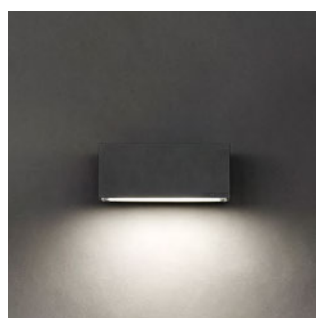
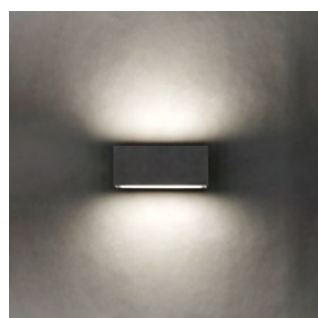
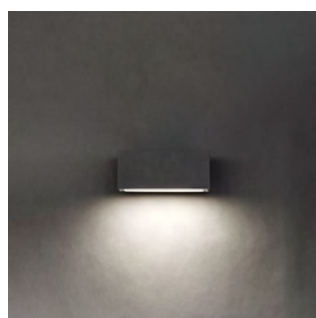

Afrodita LED Small Single Emission

BODY MAT	DIF MAT		IP	IK	50000h	BREEAM	3	SEA SIDE SUITABLE		
AL	GLA		65	04	L80 B20	MacAdam				

Z5 14 34

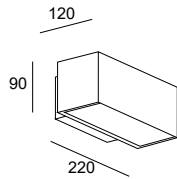
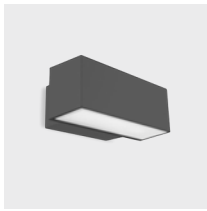

LED						
K	CRI	W Total	Real Lm	Code		
3000	80	12.7	1004	Z5	ON-OFF 100-240V	
				05-9912 - 14 - CL	ON-OFF 100-240V	
				34		
4000	80	12.7	1004	05-9912 - Z5 - CM	ON-OFF 100-240V	

Afrodita LED Big Single Emission

BODY MAT	DIF MAT		IP	IK	50000h	BREEAM	3	SEA SIDE SUITABLE		
AL	GLA		66	04	L80 B20	MacAdam				

Z5 14 34

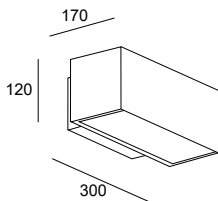

LED						
K	CRI	W Total	Real Lm	Code		
3000	80	23.3	1984	05-E092 Z5	ON-OFF 220-240V	
			2144	05-E047 - 14 - CL	DALI-2 100-240V	
			2144	05-E020 34	CASAMBI 100-240V	
4000	80	23.3	2182	05-E092	ON-OFF 220-240V	
			2358	05-E047 - Z5 - CM	DALI-2 100-240V	
			2358	05-E020	CASAMBI 100-240V	

Afrodita LED Small Double Emission

BODY MAT	DIF MAT		IP	IK	50000h	BREEAM	3	SEA SIDE SUITABLE		
AL	GLA		65	04	L80 B20	MacAdam				

Z5 14 34

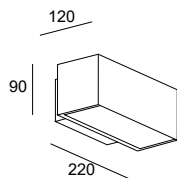

LED						
K	CRI	W Total	Real Lm	Code		
3000	80	17.9	1644	Z5	ON-OFF 100-240V	
				05-9911 - 14 - CL	ON-OFF 100-240V	
				34		
4000	80	17.9	1808	05-9911 - Z5 - CM	ON-OFF 100-240V	

Afrodita LED Big Double Emission

BODY MAT	DIF MAT		IP	IK	LOW FLICKER	BREEAM	50000h	3	SEA SIDE SUITABLE		
AL	GLA		66	04	L80 B20	MacAdam					

Z5 14 34

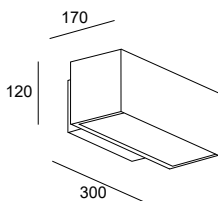

LED						
K	CRI	W Total	Real Lm	Code		
3000	80	40.7	3834	05-E070 Z5	ON-OFF 220-240V	
				05-E048 - 14 - CL	DALI-2/PUSH 220-240V	
				05-E021 34	CASAMBI 220-240V	
4000	80	40.7	4216	05-E070	ON-OFF 220-240V	
				05-E048 - Z5 - CM	DALI-2/PUSH 220-240V	
				05-E021	CASAMBI 220-240V	
3000	80	43.3	3288	05-9878 - 34 - CL	ON-OFF 100-240V	

Afrodita Power Led



Popular choice
for vertical light emission
L'applique la plus utilisée pour
projeter la lumière verticalement



Afrodita Power LED on the façade of Hotel Plaza Barcelona. Photography: Jordi Anguera
Afrodita Power LED sur la façade de l'hôtel Plaza Barcelona. Photographie : Jordi Anguera

14

34

DL

E3

J6

Z5

60



Afrodita Power LED Single Emission

BODY MAT	DIF MAT
AL	GLA



IP
65

IK
10

LOW
FLICKER

BREEAM

50000h
L80 B20

3
MacAdam

SEA SIDE
SUITABLE



Z5 14* 60* 34* J6* E3* DL*

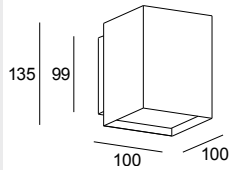

LED

K	CRI	W Total	Real Lm	Optics	Code	
2700	80	13	1136	26°	05-E056	Z5 J6 E3 - DL - CK ON-OFF 100-240V 14 60 34
3000	80	13	1136	26°	05-E056	Z5 J6 E3 - DL - CL ON-OFF 100-240V 14 60 34
4000	80	13	1136	26°	05-E056	Z5 J6 E3 - DL - CM ON-OFF 100-240V 14 60 34

Afrodita Power LED Double Emission

BODY MAT	DIF MAT
AL	GLA



IP
55

IK
04

50000h
L80 B20

3
MacAdam

SEA SIDE
SUITABLE



Z5 14* 60* 34* J6* E3* DL*

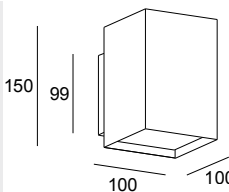

LED

K	CRI	W Total	Real Lm	Optics	Code	
2700	80	13	1136	26°	05-9773	Z5 J6 E3 - DL - CK ON-OFF 100-240V 14 60 34
3000	80	21.6	1324	22°	05-9773	Z5 J6 E3 - DL - 37 ON-OFF 100-240V 14 60 34
4000	80	21.6	1390	22°	05-9773	Z5 J6 E3 - DL - CM ON-OFF 100-240V 14 60 34

* Please contact our sales team for conditions and delivery times.

* Consultez notre équipe commerciale pour connaître les conditions et les délais de livraison.

Afrodita GU10



Same design,
with GU10 bulbs
Le même design, mais
avec des ampoules GU10

Single emission



Double emission



**Afrodita GU10
Single Emission**

BODY MAT	DIF MAT		IP	IK	SEA SIDE SUITABLE
AL	GLA		65	10	

● ○ ●
Z5 14 34

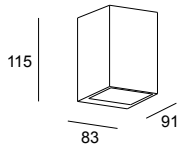
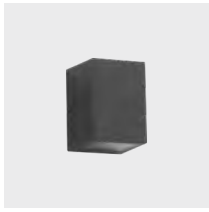

GU10	
W	Code
Max. 8	Z5 05-E054 - 14 - 37 34



OUTDOOR

**Afrodita GU10
Double Emission**

BODY MAT	DIF MAT		IP	IK	SEA SIDE SUITABLE
AL	GLA		55	06	

● ○ ●
Z5 14 34

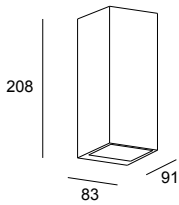
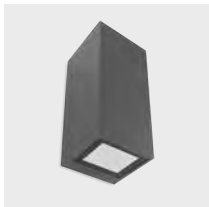

GU10	
W	Code
2 × Max. 8	Z5 05-9919 - 14 - 37 34



WALL FIXTURES | APPLIQUES

Nemesis

Essential SOLUTION

Designed by LedsC4 Architectural



Collection for residential façades Collection pour façades à usage résidentiel

The timeless design and compact size of the Nemesis wall lights, along with their proven reliability, have made this collection one of the most popular choices for residential façades. The wall light offers the choice of single or dual emission when installing, lending extra versatility for all kinds of projects.

Le design intemporel et la taille compacte des appliques Nemesis, ainsi que leur fiabilité éprouvée, ont fait de cette collection l'une des plus utilisées sur les façades résidentielles. Ce modèle permet de choisir entre mono et double émission lors de l'installation, ce qui lui confère un plus de polyvalence très utile dans les projets.

Nemesis Slim

BODY MAT	DIF MAT		IP	IK	BREEAM	50000h	3	SWITCH CCT	SEA SIDE		
AL	GLA		65	06		L80 B20	MacAdam	2700-3200-4000	SUITABLE		

Z5 14 34 J6

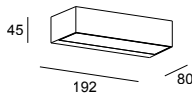

LED							
K	CRI	W Total	Real Lm	Code			
2700-3200-4000	80	8.8	830	05-E162	Z5	J6	- EH ON-OFF 100-240V
					14	34	



The indicated flux corresponds to the core temperature.
Le flux indiqué correspond à la température centrale.

Nemesis LED 170mm

BODY MAT	DIF MAT		IP	IK	BREEAM	50000h	3	SWITCH CCT	SEA SIDE		
AL	GLA		65	06		L80 B20	MacAdam	2700-3200-4000	SUITABLE		

Z5 14 34 J6

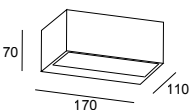

LED							
K	CRI	W Total	Real Lm	Code			
2700-3200-4000	80	12.6	1186	05-E026	Z5	J6	- EH ON-OFF 100-240V
					14	34	



The indicated flux corresponds to the core temperature.
Le flux indiqué correspond à la température centrale.

Nemesis R7S 170mm

BODY MAT	DIF MAT		50000h	IP	IK	SEA SIDE SUITABLE
AL	GLA		L80 B20	44	06	

Z5 14 34 J6

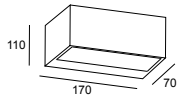
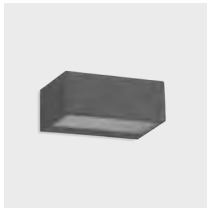

R7s	
W	Code
Max. 100	Z5 J6 05-9177 - 14 - B8 34



Nemesis LED 220mm

BODY MAT	DIF MAT		IP	IK	BREEAM	50000h	3	SWITCH CCT	SEA SIDE SUITABLE		
AL	GLA		65	06		L80 B20	MacAdam	2700-3200-4000			

Z5 14 34 J6

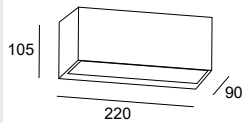

LED	
K	CRI W Total Real Lm Code
2700-3200-4000	80 19.2 1816 05-E027 - J6 - EH ON-OFF 100-240V 14 - 34

The indicated flux corresponds to the core temperature.
Le flux indiqué correspond à la température centrale.



Nemesis E27 220mm

BODY MAT	DIF MAT		IP	IK	SEA SIDE SUITABLE
AL	GLA		54	04	

Z5 14 34 J6

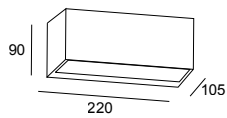
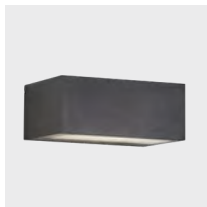

E27	
W	Code
Max. 15	Z5 J6 05-9649 - 14 - T2 34



Lens accessories Accessoires optiques



Light shutter to switch from double to single emission
Obturbateur de lumière permettant de passer de double émission à mono émission

Included

Wilson

Designed by LedsC4 Architectural



A touch of elegance for all types of walls Un plus d'élégance sur toutes sortes de murs

Wilson's clean, slightly rounded design and concealed hardware, along with its defined light beam and the suggestive play of light and shadow it creates, make this collection a sought-after choice for projects requiring an extra touch of elegance.

La ligne épurée et légèrement arrondie de Wilson, avec sa visserie dissimulée, ainsi que son faisceau lumineux défini et son séduisant jeu d'ombre et de lumière, font de cette collection un élément très apprécié dans les projets qui nécessitent une touche d'élégance supplémentaire.

The light output angle can be changed quickly and easily according to the space's needs (05-9683).

Offre la possibilité de modifier l'angle de sortie lumineuse en fonction des besoins de l'espace, en toute rapidité et simplicité (05-9683).

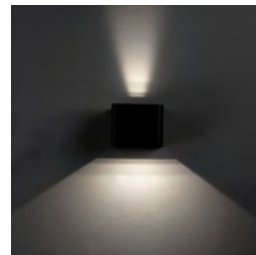
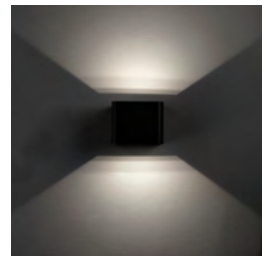
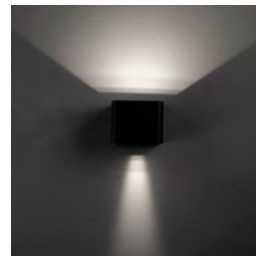

Wilson Square

BODY MAT
AL

DIF MAT
GLA



50000h
L80 B20

3
MacAdam

IP
65

IK
08

BREEAM

SEA SIDE SUITABLE



● ● ●
Z5 14 J6

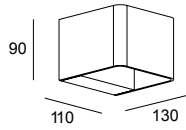

LED						
K	CRI	W Total	Real Lm	Code		
2700	80	10.2	623	05-9683 - Z5 - CK	ON-OFF 100-240V	
Z5						
3000	80	10.2	623	05-9683 - J6 - CL	ON-OFF 100-240V	
14						

Wilson Rectangular

BODY MAT
AL

DIF MAT
GLA



50000h
L80 B20

3
MacAdam

IP
65

IK
08

SEA SIDE SUITABLE



●
Z5

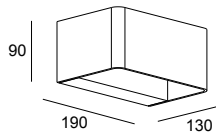

LED						
K	CRI	W Total	Real Lm	Code		
3000	80	20.7	916	05-9684 - Z5 - CL	ON-OFF 100-240V	

Clous

Designed by LedsC4 Architectural



Ideal for decorating facades Idéale pour la décoration de façades

These shallow wall lights can be integrated into the architecture to easily go unnoticed. This collection has been designed to lend a touch of personality to façades with its defined light effects.

Très peu profondes, ces appliques se fondent dans l'architecture et passent facilement inaperçues. Cette collection est conçue pour donner de la personnalité aux façades grâce à ses effets lumineux définis.

Cloud Single Emission

BODY MAT	DIF MAT		50000h	3	IP	IK	SEA SIDE SUITABLE		
AL	GLA		L80 B20	MacAdam	66	03			

Z5
 14

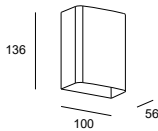

LED								
K	CRI	W Total	Real Lm	Optics	Code			
3000	80	11	537	89°	05-9926 - Z5 - CL	14	ON-OFF 100-240V	

Cloud Double Emission

BODY MAT	DIF MAT		50000h	3	IP	IK	BREEAM	SEA SIDE SUITABLE		
AL	GLA		L80 B20	MacAdam	66	03				

Z5
 14

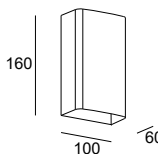

LED								
K	CRI	W Total	Real Lm	Optics	Code			
3000	80	13	758	86°	05-9679 - Z5 - CL	14	ON-OFF 100-240V	

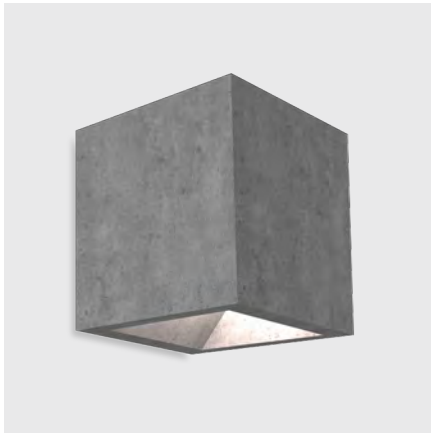
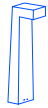

Integration and visual comfort Intégration et confort visuel

The Up&Down Simenti wall light is made of 100% cement. Offering high visual comfort, this model is often chosen for luxury residences, especially for concrete façades, to achieve total integration into the architecture.

L'applique Up&Down Simenti est 100 % en ciment. Offrant un confort visuel élevé, c'est une option particulièrement appréciée dans les résidences de standing, notamment sur les façades en béton, pour une intégration architecturale totale.

Simenti

BODY MAT CON	DIF MAT GLA		3 MacAdam	IP 66	IK 10	SEA SIDE SUITABLE		
-----------------	----------------	--	--------------	----------	----------	----------------------	--	--

DC

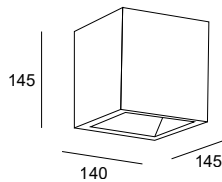

LED

K	CRI	W Total	Real Lm	Code	
3000	80	10.7	365	05-9971 - DC - CL	ON-OFF 100-240V

Diago

Designed by LedsC4 Architectural

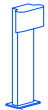

Understated and elegant Discrète et élégante

The Diago wall light features a restrained design and a subdued light package. Its double cable outlet allows multiple lights to be installed in a row along the perimeter of the façade more easily.

L'applique Diago arbore un design sobre et une charge lumineuse qui n'est pas excessive. Sa double sortie de câble facilite l'installation en chaîne et rend possible sa pose sur tout le périmètre d'une façade.

Diago

BODY MAT AL	DIF MAT GLA		3 MacAdam	IP 65	IK 05	BREEAM		
----------------	----------------	--	--------------	----------	----------	--------	--	--

Z5

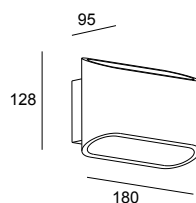

LED

K	CRI	W Total	Real Lm	Code	
3000	80	9.8	680	05-E065 - Z5 - CL	ON-OFF 220-240V

Finestra

Designed by LedsC4 Architectural



+ Finestra



Spectacular façades with their own personality Des façades spectaculaires à la personnalité marquée

Finestra illuminates façades with spectacular light effects, which offer limitless possibilities thanks to the combination of different filters and their DMX control option.

Finestra illumine les façades avec des effets lumineux spectaculaires, qui offrent de nombreuses possibilités grâce à la combinaison de différents filtres et à l'option de contrôle DMX.

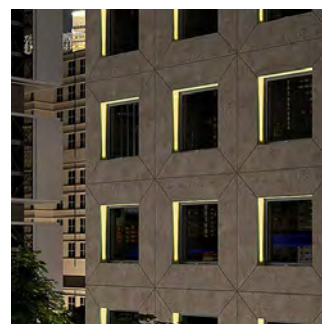
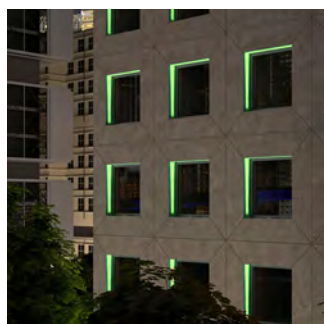

The Standard version has interchangeable blue, green, red and yellow colour filters.

La version Standard comprend des filtres de couleur interchangeables en bleu, vert, rouge et jaune.

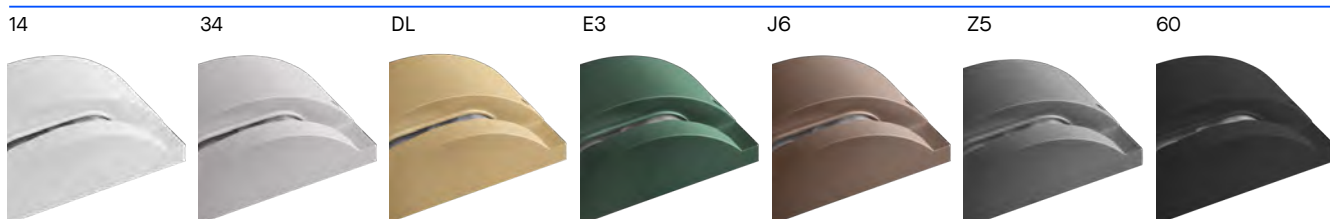
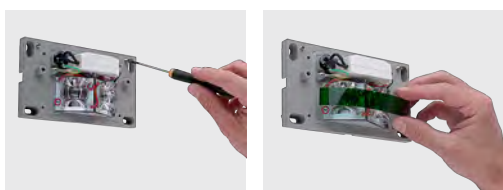

Finestra Standard

BODY MAT	DIF MAT		50000h	3
AL	PC		L80 B20	MacAdam

OUTDOOR

The more affordable option L'option la plus économique

Maximum versatility thanks to the 3000K, yellow, red, blue and green filters included.
Maximum de polyvalence grâce aux filtres 3 000 K fournis en jaune, rouge, bleu et vert.

Finestra Standard

IK		SEA SIDE SUITABLE
10	1.5 m	

Z5* 14* 60* 34 J6* E3* DL*

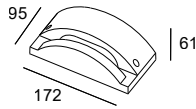

LED							
K	CRI	W Total	Real Lm	Optics	Code		
						Z5	
						J6	
						E3	
4000*	80	5.4	281	11x180°	10-9903 - DL - CM	ON-OFF	100-240V
						14	
						60	
						34	

* Please contact our sales team for conditions and delivery times.
* Consultez notre équipe commerciale pour connaître les conditions et les délais de livraison.

Finestra DMX

The advanced option, for total control L'option pointue pour un contrôle total

The professional DMX RDM system saves time on installation because the DMX address is conveniently assigned to each luminaire from a PC using free software. This application offers an endless array of combinations and lighting options. It also includes a diffuser filter that blurs the light effect.

Le système professionnel DMX RDM permet d'économiser du temps d'installation car l'attribution de l'adresse DMX à chaque luminaire se fait commodément depuis l'ordinateur grâce à un logiciel gratuit. Cette application ouvre d'infinies possibilités de combinaison et d'éclairage. Le modèle comprend également un filtre diffuseur qui permet d'estomper l'effet lumineux.

Finestra RGBW DMX

IP	IK	LOW		SEA SIDE SUITABLE			
66	10	FLICKER					

Z5* 14* 60* 34 J6* E3* DL*

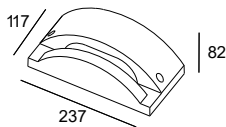

LED							
K	CRI	W Total	Real Lm	Optics	Code		
						Z5	
						J6	
						E3	
RGBW 4000*	80	10.8	414	3x180°	10-E077 - DL - 00	DMX RDM	100-277V
						14	
						60	
						34	

* Please contact our sales team for conditions and delivery times.
* Consultez notre équipe commerciale pour connaître les conditions et les délais de livraison.

* The indicated flow corresponds to the temperature White = 4000 K

* Le flux indiqué correspond à la température White= 4 000 K

** This product may require programming by a specialist. LedsC4 offers consulting services on control systems and programming in the factory or on-site. Ask your sales agent for more info.

** Ce produit peut nécessiter une programmation par un spécialiste. LedsC4 offre des services de conseils pour les systèmes de contrôle et de programmation en usine ou sur place. Consultez votre agent commercial.

WALL FIXTURES | APPLIQUES



Finestra Standard

Finestra RGBW DMX







Lens accessories

Accessoires optiques

	Colour diffusers Diffuseurs de couleurs	Included	-
	Diffuser filter Filtre diffuseur	-	Included
	3000K diffuser Diffuseur 3 000 K	Included	-

Connection accessories

Accessoires de connexion

	IP68 connector (1 inlet + 1 outlet) Ø 5,5 - 11,5mm, 4 poles Connecteur IP68 (1 entrée + 1 sortie) Ø 5,5 - 11,5 mm, 4 pôles	71-E512-00-00	-
	IP68 connector (1 inlet + 2 outlets) Ø 5,5 - 11,5mm, 3 poles Connecteur IP68 (1 entrée + 2 sorties) Ø 5,5 - 11,5 mm, 3 pôles	71-E513-00-00	-
	IP68 anti-condensation connector (1 input + 1 output) Ø 5,5-12 mm, 4 poles Connecteur anticondensation IP68 (1 entrée + 1 sortie) Ø 5,5 - 12 mm, 4 pôles	71-E112-00-00	-
	IP68 anti-condensation connector (1 input + 3 outputs) Ø 5,5-12 mm, 4 poles Connecteur anticondensation IP68 (1 entrée + 3 sorties) Ø 5,5 - 12 mm, 4 pôles	71-E122-00-00	-
	IP68 connection box (1 input + 5 outputs) Ø 6,5-11 mm, 6 poles Boîtier de raccordement IP67 (1 entrée + 5 sorties) Ø 6,5 - 11 mm, 6 pôles	71-9199-05-05	-

Connective controllers

Contrôleurs connectés

P. 969

**Consult the available control systems / Consultez les systèmes de contrôle disponibles:**

Bluetooth wireless / Sans fil Bluetooth

DMX / DMX

Autonomous / Autonome

Rack

Designed by LedsC4 Architectural



Rechargeable
P. 892



Plug&Play
P. 892

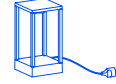

Bollard
P. 892

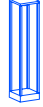

OUTDOOR



Versatile and adaptable to the space Polyvalente et adaptable à l'espace

It's not easy to find decorative luminaires with advanced performance features, such as an IP66 rating, DALI lighting control, BREEAM efficiency or a special treatment to withstand coastal conditions. Rack has been painstakingly developed for those projects where lighting and decorating with personality is not enough, but reliability is an equal or even more important factor.

Il n'est pas facile de trouver des appliques décoratives à hautes performances qui offrent notamment l'indice IP66, la gradation DALI, l'efficacité BREEAM ou encore un traitement spécial pour milieu marin. L'applique Rack a été soigneusement conçue pour les projets qui exigent davantage qu'un éclairage décoratif et personnalisé, mais où la fiabilité est un facteur tout aussi important, voire plus.

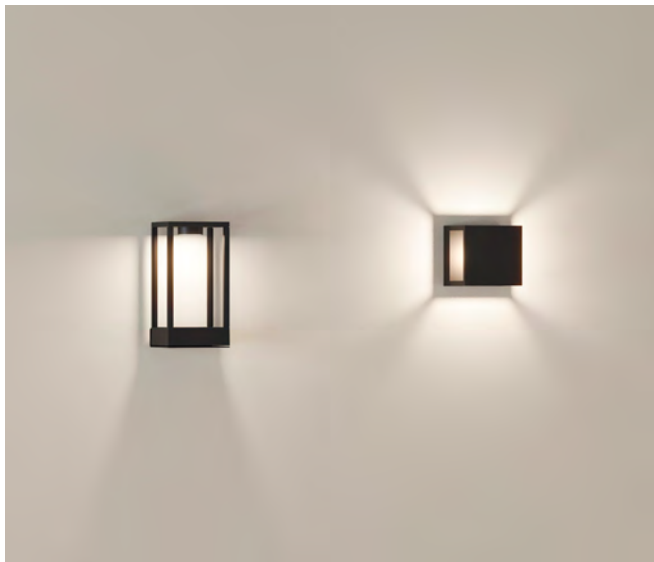

WALL FIXTURES | APPLIQUES

14

34

DL

E3

J6

Z5

60



823

Rack Wall Fixture

BODY MAT	DIF MAT		50000h	3
AL.CON	GLA		L80 B20	MacAdam

Rack Wall Fixture 150x150x160mm

IP	IK	BREEAM	SWITCH CCT		SEA SIDE		
66	06		2700-3200-4000	2 m	SUITABLE		

Z5* 14* 60 34* J6* E3* DL*



05-E071 05-E076 05-E077

LED										
K	CRI	W Total	Real Lm	Code						
2700-3200-4000	80	14.9	760		Z5					
					J6					
					E3	OU	ON-OFF	100-277V		
					- DL	- DU	DALI-2	100-277V		
					14	XB	CASAMBI	220-240V	⚡	
					60					
	34									

The indicated flux corresponds to the core temperature.
Le flux indiqué correspond à la température centrale.

Rack Wall Fixture 150x150x300mm

IP	IK	BREEAM	SWITCH CCT		SEA SIDE		
66	06		2700-3200-4000	2 m	SUITABLE		

Z5* 14* 60 34* J6* E3* DL*

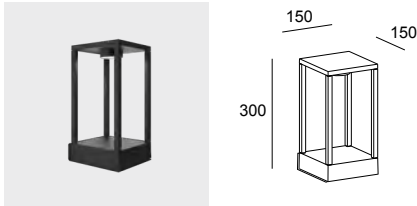

05-E082 05-E088 05-E089

LED										
K	CRI	W Total	Real Lm	Code						
2700-3200-4000	80	14.9	760		Z5					
					J6					
					E3	OU	ON-OFF	100-277V		
					- DL	- DU	DALI-2	100-277V		
					14	XB	CASAMBI	220-240V	⚡	
					60					
	34									

The indicated flux corresponds to the core temperature.
Le flux indiqué correspond à la température centrale.

* Please contact our sales team for conditions and delivery times.
* Consultez notre équipe commerciale pour connaître les conditions et les délais de livraison.

Rack Wall Fixture
150×150×160mm



Rack Wall Fixture
150×150×300mm



Lens accessories

Accessoires optiques



Spherical opal glass diffuser
Diffuseur sphérique en verre opalin

-

71-E284-60-F9

Connection accessories

Accessoires de connexion



IP68 connector (1 input + 1 output) Ø 6–17 mm, 5 poles
Connecteur IP68 (1 entrée + 1 sortie) Ø 6 - 17 mm, 5 pôles

71-E361-00-00

71-E361-00-00



IP68 anti-condensation connector (1 input + 1 output)
Ø 5.5–12 mm, 4 poles
Connecteur anticondensation IP68 (1 entrée + 1 sortie)
Ø 5,5 - 12 mm, 4 pôles

71-E112-00-00

71-E112-00-00



IP68 anti-condensation connector (1 input + 3 outputs)
Ø 5.5–12 mm, 4 poles
Connecteur anticondensation IP68 (1 entrée + 3 sorties)
Ø 5,5 - 12 mm, 4 pôles

71-E122-00-00

71-E122-00-00



IP68 connection box (1 input + 5 outputs) Ø 6.5–11 mm,
6 poles
Boîtier de raccordement IP67 (1 entrée + 5 sorties) Ø
6,5 - 11 mm, 6 pôles

71-9199-05-05

71-9199-05-05

Decorative accessories

Accessoires décoratifs



Decorative grids set (4u.)
Set de grilles décoratives (4 u.)

Z5 ●

71-E278-Z5-00

71-E279-Z5-00

14 ○

71-E278-14-00

71-E279-14-00

60 ●

71-E278-60-00

71-E279-60-00

34 ○

71-E278-34-00

71-E279-34-00

J6 ●

71-E278-J6-00

71-E279-J6-00

E3 ●

71-E278-E3-00

71-E279-E3-00

DL ●

71-E278-DL-00

71-E279-DL-00

Moal

Designed by Francesc Vilaró



+ Moal

Wall Fixture
P. 904

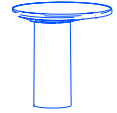

Moal wall light Moal applique

The Moal collection, comprising wall fixtures and bollards, is designed to provide a warm and subtle lighting solution for architectural spaces, with a concrete finish that seamlessly blends with the environment.

Constituée d'une applique et d'une borne, la collection Moal est conçue pour éclairer de façon chaleureuse et subtile les espaces architecturaux où la finition en ciment permet une intégration totale dans l'environnement.



Accessory for achieving double height Accessoire permettant de créer une double hauteur

Compositions can be created by utilising the lift to arrange wall fixtures at different heights.

Possibilité de créer des compositions grâce à l'élévateur, afin de jouer avec des appliques de hauteurs différentes.

Moal Wall Fixture

BODY MAT
AL.CON

DIF MAT
PC



50000h
L80 B20

3
MacAdam

IP
66

IK
10

LOW
FLICKER



SEA SIDE
SUITABLE



DC

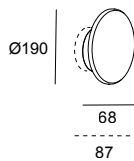
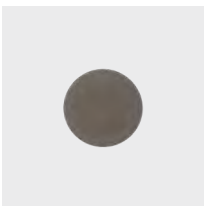

LED

K	CRI	W Total	Real Lm	Code	
3000	90	11.1	312	05-E087 - DC - CL	ON-OFF 100-240V

Fixing accessories

Accessoires de fixation



Elevating accessory
Élévateur

Included



Arc

Designed by LedsC4 Architectural



+ Arc

Ideal for concrete façades Idéale pour les façades en béton

Arc is made entirely of cement, allowing for
easy integration into architecture.

Étant entièrement réalisée en ciment, l'applique
Arc se fond facilement dans l'architecture.



Can be surface-mounted
or recessed
Possibilité d'installation
en surface ou encastrée.





High visual comfort
Grand confort visuel

Arc

BODY MAT AL.CON	DIF MAT GLA		50000h L80 B20	3 MacAdam	IP 66	IK 10		SEA SIDE SUITABLE		
--------------------	----------------	--	-------------------	--------------	----------	----------	--	----------------------	--	--

DC

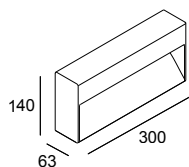

300x140

LED						
K	CRI	W Total	Real Lm	Code		
3000	80	9	404	05-E090 - DC - CL	ON-OFF 230V	

Fixing accessories
Accessoires de fixation



Recess case
Boîtier d'encastrement

71-E090-Z5-00

Sam

Designed by Francesc Vilaró



+ Sam



Elegance and style in a compact profile Élégance et style dans un profilé compact

Sam goes one step further to become a landmark solution for transit areas. This collection does not need to be recessed thanks to its compact size, and also includes drivers and offers very high performance. In addition, its clean design without visible hardware, together with an extensive range of finishes, make it suitable for both outdoor and indoor use.

Sam a tout pour devenir une référence en matière d'éclairage des zones de passage. N'ayant pas besoin d'être encastrée grâce à sa taille compacte, cette collection comprend néanmoins un driver et offre des prestations très élevées. Par ailleurs, son design épuré sans vis apparentes, allié à un vaste éventail de finitions, en font une famille adaptée aussi bien en intérieur qu'en extérieur.

180 mm



140 mm



14

34

DL

E3

J6

Z5

60





Illuminates transit areas with precision and high visual comfort

Éclaire les zones de passage avec précision en tout confort visuel

Sam 180 mm

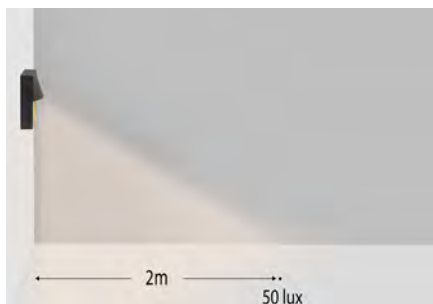
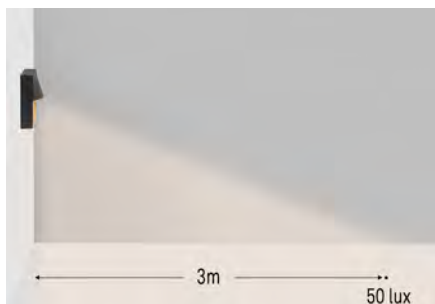

Sam 140 mm

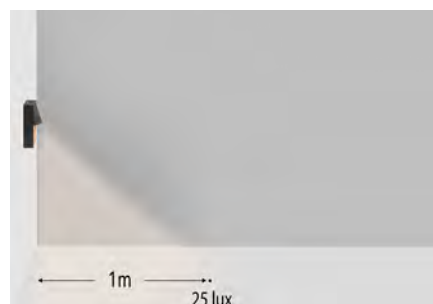
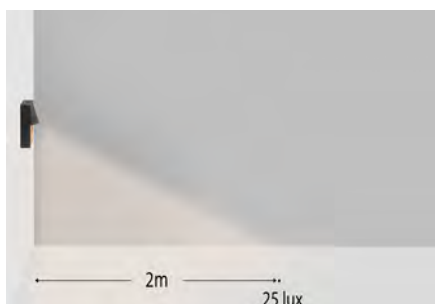

Colour temperature change switch included

Interrupteur de changement de température de couleur fourni

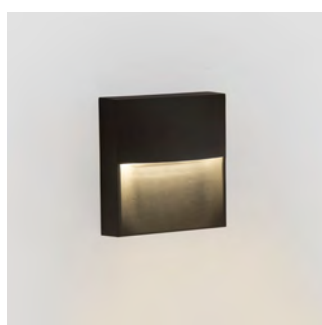
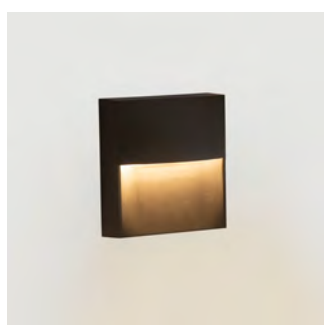
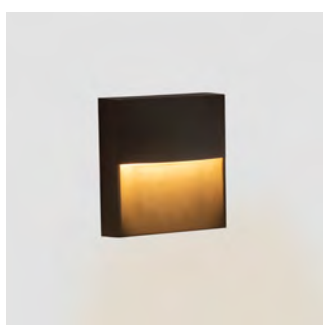

Sam
140mm

BODY MAT
AL

DIF MAT
PC



50000h
L80 B20

3
MacAdam

IP
66

IK
10

SWITCH CCT
2700-3200-4000



Z5 14* 60* 34* J6* E3* DL*

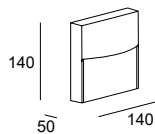
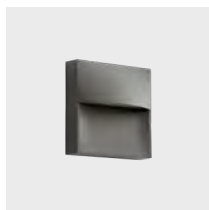

LED						
K	CRI	W Total	Real Lm	Code		
2700-3200-4000	80	3.5	269	05-E059	Z5 J6 E3 DL - EH	ON-OFF 220-240V
					14 60 34	

The indicated flux corresponds to the core temperature.
Le flux indiqué correspond à la température centrale.

Sam
180mm

BODY MAT
AL

DIF MAT
PC



50000h
L80 B20

3
MacAdam

IP
66

IK
10

SWITCH CCT
2700-3200-4000



Z5 14* 60* 34* J6* E3* DL*

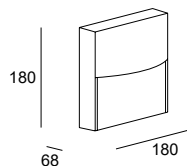

LED						
K	CRI	W Total	Real Lm	Code		
2700-3200-4000	80	18.5	1458	05-E068 05-E058	Z5 J6 E3 DL - EH	ON-OFF 100-240V DALI-2 120-277V
					14 60 34	

The indicated flux corresponds to the core temperature.
Le flux indiqué correspond à la température centrale.

* Please contact our sales team for conditions and delivery times.
* Consultez notre équipe commerciale pour connaître les conditions et les délais de livraison.

Kössel

Essential
SOLUTION

Designed by LedsC4 Architectural

A false recessed light with a plethora of options Un faux encastré qui offre de nombreuses options

Kössel offers subtle lighting for transit areas. Its shallow depth makes it appear almost like a recessed wall light, however this is a surface light that comes with a built-in driver for easier and more budget-friendly installation.

Kössel éclaire les zones de passage en douceur. Alors que sa faible profondeur est plus typique d'un encastré de mur, ce modèle est non seulement monté en surface, mais également livré avec un driver, ce qui rend son installation facile et économique.



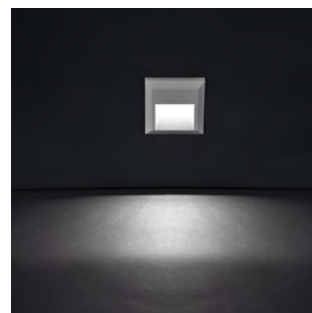

Kössel Indirect



Kössel Direct



BODY MAT PC+ABS	DIF MAT PC		50000h L80 B20	3 MacAdam
--------------------	---------------	------------------------------------------------------------------------------------	-------------------	--------------

IP 65	IK 10	BREEAM		SEA SIDE SUITABLE	LED	DRIVER
----------	----------	--------	-------------------------------------------------------------------------------------	----------------------	-----	--------

34

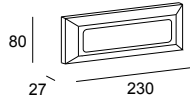

LED						
K	CRI	W Total	Real Lm	Code		
3000	80	3.8	238	05-9779 - 34 - CL	ON-OFF	100-240V
4000	80	3.8	262	05-9779 - 34 - CM	ON-OFF	100-240V

Fixing accessories Accessoires de fixation



White housing
Pièce frontale blanche

Included



Light grey housing
Pièce frontale gris clair

Included



Grey housing
Pièce frontale grise

Included

Kössel

Wall Fixture Indirect

BODY MAT	DIF MAT		50000h	3
PC+ABS	PC		L80 B20	MacAdam

Kössel Indirect Square 125mm

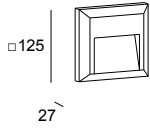

IP	IK	SEA SIDE SUITABLE	LED	DRIVER
65	10			

14



LED					
K	CRI	W Total	Real Lm	Code	
4000	80	1.5	65	05-9802 - 14 - CM	ON-OFF 100-240V

Kössel Indirect Square 200mm

IP	IK	LOW FLICKER		SEA SIDE SUITABLE	LED	DRIVER
66	10					

14

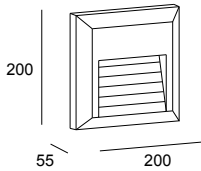



LED					
K	CRI	W Total	Real Lm	Code	
4000	80	7	295	05-E069 - 14 - CM	ON-OFF 220-240V

Kössel Indirect Rectangular

IP	IK		SEA SIDE SUITABLE	LED	DRIVER
65	10				

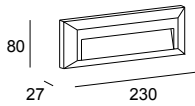
14



LED					
K	CRI	W Total	Real Lm	Code	
4000	80	2.4	91	05-9814 - 14 - CM	ON-OFF 100-240V

Kössel Indirect Square 125mm



Kössel Indirect Square 200mm



Kössel Indirect Rectangular



Lens accessories

Accessoires optiques



3000K diffuser
Diffuseur 3 000 K

Included

Included

Included

Fixing accessories

Accessoires de fixation

White housing
Pièce frontale blanche

Included

Included

Included

Light grey housing
Pièce frontale gris clair

Included

Included

Included

Grey housing
Pièce frontale grise

Included

Included

Included



Elegant direct light Élégante lumière directe

Skat es una colección de apliques de iluminación directa, de diseño atemporal y uso versátil. Se presenta en tres medidas y puede personalizarse con los colores ofrecidos por LedsC4. Esta luminaria proyecta una luz homogénea, e incluye tecnología CCT.

Skat est une collection d'appliques d'éclairage direct, au design intemporel et à usage polyvalent. Le modèle est proposé en trois tailles et peut être personnalisé dans les coloris standard offerts par LEDS C4. Projetant une lumière homogène, ce luminaire est doté de la technologie CCT.

500mm

350mm

200mm

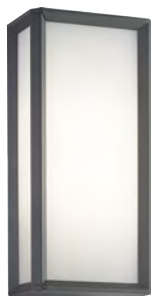

14

34

DL

E3

J6

Z5

60





CCT switch included Interrupteur CCT fourni



2700K



3200K



4000K



05-E055, 05-E109

Skat Wall Fixture

BODY MAT	DIF MAT		50000h	3
AL	PC		L80 B20	MacAdam

Skat 200mm

IP	IK	BREEAM	SWITCH CCT	SEA SIDE SUITABLE	LED	DRIVER
65	10		2700-3200-4000			

Z5 14* 60* 34* J6* E3* DL*

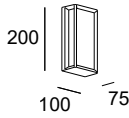
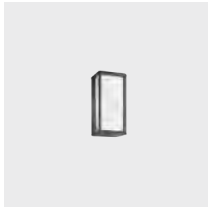

LED						
K	CRI	W Total	Real Lm	Code		
				Z5		
				J6		
				E3		
2700-3200-4000	80	10	602	05-E028 - DL - EH	ON-OFF	100-240V
				14		
				60		
				34		

The indicated flux corresponds to the core temperature.
Le flux indiqué correspond à la température centrale.

Skat 350mm

IP	IK	LOW	BREEAM	SWITCH CCT		SEA SIDE SUITABLE	LED	DRIVER
65	10	FLICKER		2700-3200-4000				

Z5 14* 60* 34* J6* E3* DL*

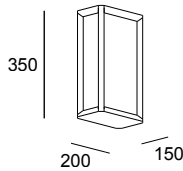

LED						
K	CRI	W Total	Real Lm	Code		
				Z5		
				J6		
				E3		
2700-3200-4000	80	23.9	1266	05-E055 - DL - EH	ON-OFF	100-240V
				14		
				60		
				34		

The indicated flux corresponds to the core temperature.
Le flux indiqué correspond à la température centrale.

Skat 500mm

IP	IK	LOW	BREEAM	SWITCH CCT		SEA SIDE SUITABLE	LED	DRIVER
65	10	FLICKER		2700-3200-4000				

Z5 14* 60* 34* J6* E3* DL*

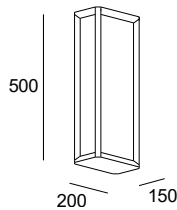

LED						
K	CRI	W Total	Real Lm	Code		
				Z5		
				J6		
				E3		
2700-3200-4000	80	23.9	1266	05-E109 - DL - EH	ON-OFF	100-240V
				14		
				60		
				34		

The indicated flux corresponds to the core temperature.
Le flux indiqué correspond à la température centrale.



Direct general light for large spaces Éclairage général direct pour grands espaces

Whether for residential or professional use, the wide selection of diffusers and light sources makes Curie the perfect collection for lighting large spaces with direct, generous and glare-free light.

Que ce soit à des fins résidentielles ou professionnelles, le choix entre différents types de diffuseurs et sources lumineuses fait de Curie la collection parfaite pour éclairer les grands espaces à l'aide d'une lumière directe, généreuse et sans éblouissement.



14

34

DL

E3

J6

Z5

60

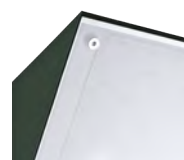

Curie Glass LED Small

IP	IK	BREEAM	50000h	3	SWITCH CCT
65	05		L80 B20	MacAdam	2700-3200-4000

SEA SIDE
SUITABLE

LED

DRIVER

- -
 -
 -
 -
 -
 -
- Z5 14* 60* 34* J6* E3* DL*

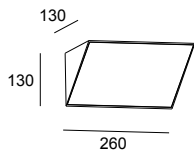

LED						
K	CRI	W Total	Real Lm	Code		
				Z5		
				J6		
				E3		
2700-3200-4000	80	14.4	792	05-E139	- DL - EH	ON-OFF 100-240V
				14		
				60		
				34		

The indicated flux corresponds to the core temperature.
Le flux indiqué correspond à la température centrale.

Curie Glass LED Big

IP	IK	BREEAM	50000h	3	SWITCH CCT
65	05		L80 B20	MacAdam	2700-3200-4000

SEA SIDE
SUITABLE

LED

DRIVER

- -
 -
 -
 -
 -
 -
- Z5 14* 60* 34* J6* E3* DL*

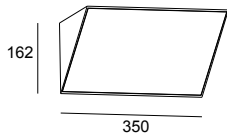
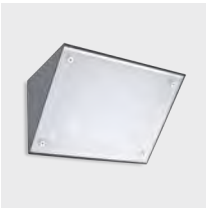

LED						
K	CRI	W Total	Real Lm	Code		
				Z5		
				J6		
				E3		
2700-3200-4000	80	28.9	2941	05-E140	- DL - EH	ON-OFF 100-240V
				14		
				60		
				34		

The indicated flux corresponds to the core temperature.
Le flux indiqué correspond à la température centrale.

Curie Glass E27 Small

IP	IK	SEA SIDE
65	05	SUITABLE

- -
 -
 -
 -
 -
 -
- Z5 14* 60* 34* J6* E3* DL*

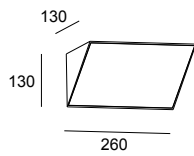

E27			
W	Real Lm	Code	
		Z5	
		J6	
		E3	
Max. 15	710	05-9884	- DL - G5
		14	
		60	
		34	

Curie Glass E27 Big

IP	IK	SEA SIDE
65	05	SUITABLE

- -
 -
 -
 -
 -
 -
- Z5 14* 60* 34* J6* E3* DL*

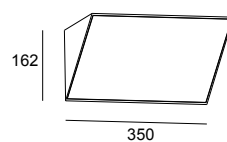

E27			
W	Real Lm	Code	
		Z5	
		J6	
		E3	
2 × Max. 15	1530	05-9993	- DL - G5
		14	
		60	
		34	

Curie PC LED Small

IP	IK	50000h	BREEAM	3	SWITCH CCT	SEA SIDE
65	10	L80 B20		MacAdam	2700-3200-4000	SUITABLE

Z5 14* 60* 34* J6* E3* DL*

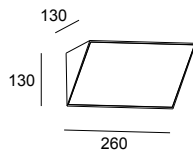

LED							
K	CRI	W Total	Real Lm	Code			
					Z5		
					J6		
					E3		
2700-3200-4000	80	14.4	792	05-E137	- DL - EH	ON-OFF	100-240V
					14		
					60		
					34		

The indicated flux corresponds to the core temperature.
Le flux indiqué correspond à la température centrale.

Curie PC LED Big

IP	IK	50000h	BREEAM	3	SWITCH CCT	SEA SIDE
65	10	L80 B20		MacAdam	2700-3200-4000	SUITABLE

Z5 14* 60* 34* J6* E3* DL*

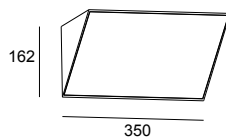
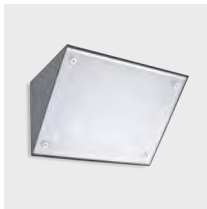

LED							
K	CRI	W Total	Real Lm	Code			
					Z5		
					J6		
					E3		
2700-3200-4000	80	28.9	2941	05-E138	- DL - EH	ON-OFF	100-240V
					14		
					60		
					34		

The indicated flux corresponds to the core temperature.
Le flux indiqué correspond à la température centrale.

Curie PC E27 Small

IP	IK	BREEAM	50000h	3	SWITCH CCT	SEA SIDE
65	10		L80 B20	MacAdam	2700-3200-4000	SUITABLE

Z5 14* 60* 34* J6* E3* DL*

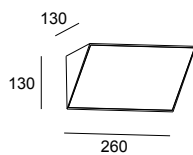

E27			
W	Real Lm	Code	
		Z5	
		J6	
		E3	
Max. 15	710	05-E144	- DL - M1
		14	
		60	
		34	

Curie PC E27 Big

IP	IK	50000h	BREEAM	3	SWITCH CCT	SEA SIDE
65	10	L80 B20		MacAdam	2700-3200-4000	SUITABLE

Z5 14* 60* 34* J6* E3* DL*

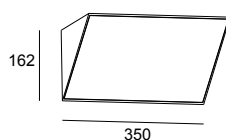

E27			
W	Real Lm	Code	
		Z5	
		J6	
		E3	
2 × Max. 15	1530	05-E145	- DL - M1
		14	
		60	
		34	

* Please contact our sales team for conditions and delivery times.
* Consultez notre équipe commerciale pour connaître les conditions et les délais de livraison.

Darwin

Essential
SOLUTION



An essential collection with two installation options: one straight and perpendicular to the wall and one that is slightly tilted forward. Featuring a geometric design, its puffed-out shape and light effect bring personality to the space.

Collection essentielle offrant deux possibilités d'installation : l'une droite, perpendiculaire au mur, et l'autre légèrement inclinée vers l'avant. De forme géométrique, sa forme bombée et son effet de lumière dotent l'espace d'une touche de personnalité.

Darwin

BODY MAT	DIF MAT		IP	IK	SEA SIDE SUITABLE
PC	PC		54	10	

●
Z5

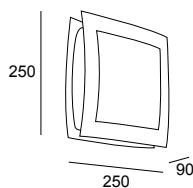

E27

W

Max. 15

Code

05-9444 - Z5 - CD



Robust and affordable Robuste et économique

Basic is an essential collection that has been revamped and improved to withstand any intensive professional use. Its general lighting through direct light lends a touch of quality to the space.

Basic est une collection essentielle qui a été mise à jour et améliorée pour résister à n'importe quel usage professionnel intensif. Son éclairage général par lumière directe apporte un plus de qualité à l'espace.

360mm



260mm



220mm



14



34



DL



E3



J6



Z5



60



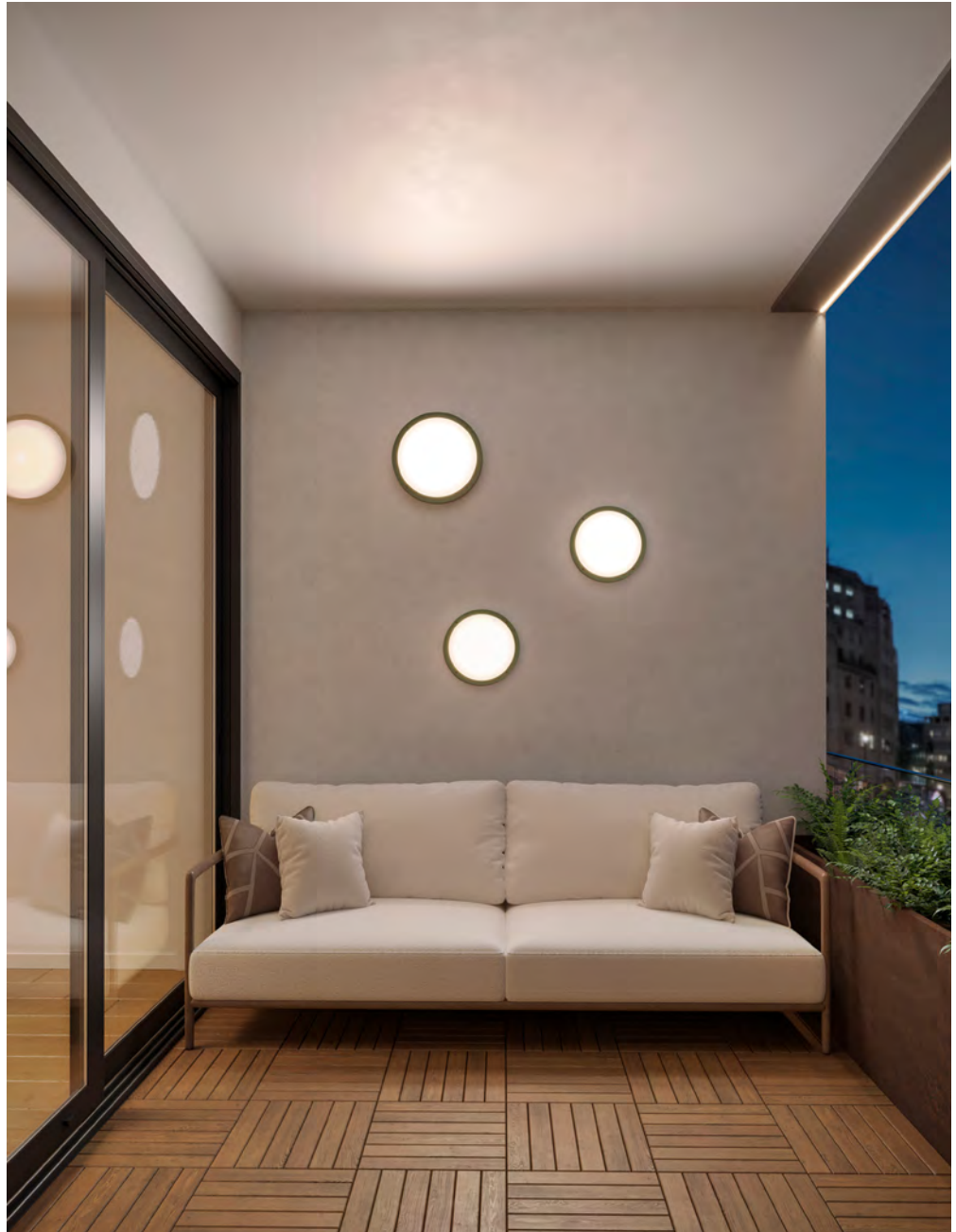

Built-in CCT switch that allows you to change the colour temperature according to the needs of the space.

Switch (interrupteur) CCT intégré qui permet de modifier la température de couleur en fonction des besoins de l'espace.

2700K



3200K



4000K



Even lighting, comfort and efficiency >80Lm/W of the diffuser

Uniformité, confort visuel et efficacité énergétique > 80 lm/W du diffuseur

Made with high-quality, transparent poly carbonate mixed with a technical additive dispersed using the heat injection and drying technique.

Fabriqué en polycarbonate transparent de grande qualité, mélangé à un additif technique dispersé à l'aide d'un séchage par chaleur et injection.

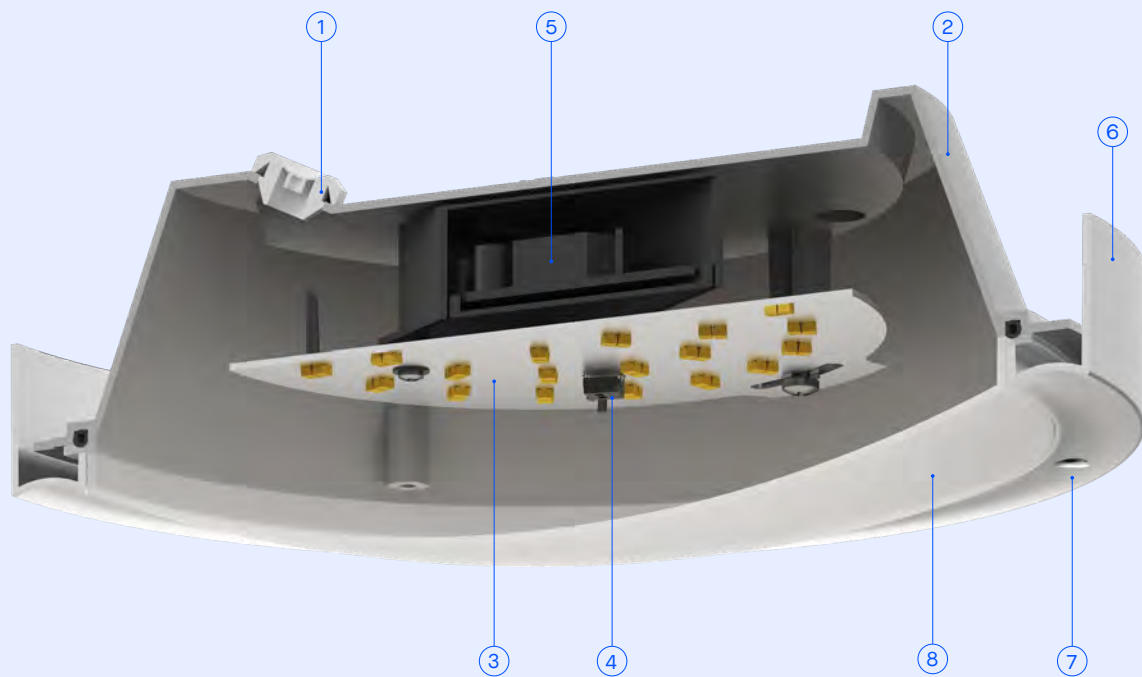

① Compression glands IP66 for maximum protection.
Presse-étoupes IP66 pour un maximum de protection.

② Base made from technopolymer for greater resistance to humidity.
Base en technopolymère pour plus de résistance à l'humidité.

③ Heat sink made from aluminium.
Dissipateur en aluminium.

④ Switch CCT. 2700K, 3200K and 4000K.
Switch CCT. 2700K, 3200K et 4000K.

⑤ Equipment included.
Appareillage fourni.

⑥ Casing made from aluminium for greater durability, with anti-rust treatment.
Corps en aluminium pour plus de robustesse et avec traitement antirouille.

⑦ Screws AISI316 stainless steel.
Visserie en acier inoxydable AISI316.

⑧ Diffuser made from polycarbonate IK10.
Diffuseur en polycarbonate IK10.

Basic

BODY MAT	DIF MAT
AL	PC

Basic Oval LED

IP	IK		50000h	3	SWITCH CCT			
66	10		L80 B20	MacAdam	2700-3200-4000			

● ○ ● ● ● ● ● ●
Z5 14* 60* 34* J6* E3* DL*

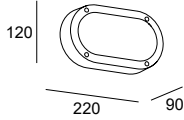

LED								
K	CRI	W Total	Real Lm	Code				
					Z5			
					J6			
					E3			
2700-3200-4000	80	8.5	793	05-E102 - DL - EH	ON-OFF	220-240V		
					14			
					60			
					34			

The indicated flux corresponds to the core temperature.
Le flux indiqué correspond à la température centrale.

Basic 260mm LED

IP	IK	UGR		BREEAM	50000h	3	SWITCH CCT			
66	10	<22		L80 B20	MacAdam	2700-3200-4000				

● ○ ● ● ● ● ● ●
Z5 14* 60* 34* J6* E3* DL*

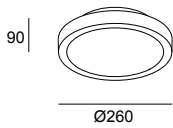

LED								
K	CRI	W Total	Real Lm	Code				
					Z5			
					J6			
					E3			
2700-3200-4000	80	13.5	1396	15-E049 - DL - EH	ON-OFF	220-240V		
					14			
					60			
					34			

The indicated flux corresponds to the core temperature.
Le flux indiqué correspond à la température centrale.

Basic 360mm LED

IP	IK	UGR	LOW		BREEAM	50000h	3	SWITCH CCT			
66	10	<22	FLICKER		L80 B20	MacAdam	2700-3200-4000				

● ○ ● ● ● ● ● ●
Z5 14* 60* 34* J6* E3* DL*

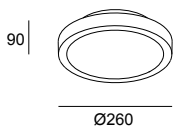

LED								
K	CRI	W Total	Real Lm	Code				
					Z5			
					J6			
					E3			
2700-3200-4000	80	24	2750	15-E050 - DL - EH	ON-OFF	220-240V		
					14			
					60			
					34			

The indicated flux corresponds to the core temperature.
Le flux indiqué correspond à la température centrale.

* Please contact our sales team for conditions and delivery times.
* Consultez notre équipe commerciale pour connaître les conditions et les délais de livraison.

**Basic Oval
E27**

IP	IK	
66	10	

Z5 14* 60* 34* J6* E3* DL*

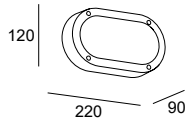

E27	
W	Code
Max. 15	Z5
	J6
	E3
	05-9886 - DL - M1
	14
	60
	34

**Basic 260mm
E27**

IP	IK	
66	10	

Z5 14* 60* 34* J6* E3* DL*

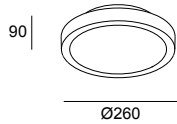

E27	
W	Code
Max. 15	Z5
	J6
	E3
	15-9835 - DL - M1
	14
	60
	34

**Basic 360mm
E27**

IP	IK	
66	10	

Z5 14* 60* 34* J6* E3* DL*

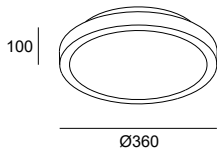

E27	
W	Code
2 × Max. 15	Z5
	J6
	E3
	15-E041 - DL - M1
	14
	60
	34

* Please contact our sales team for conditions and delivery times.
 * Consultez notre équipe commerciale pour connaître les conditions et les délais de livraison.

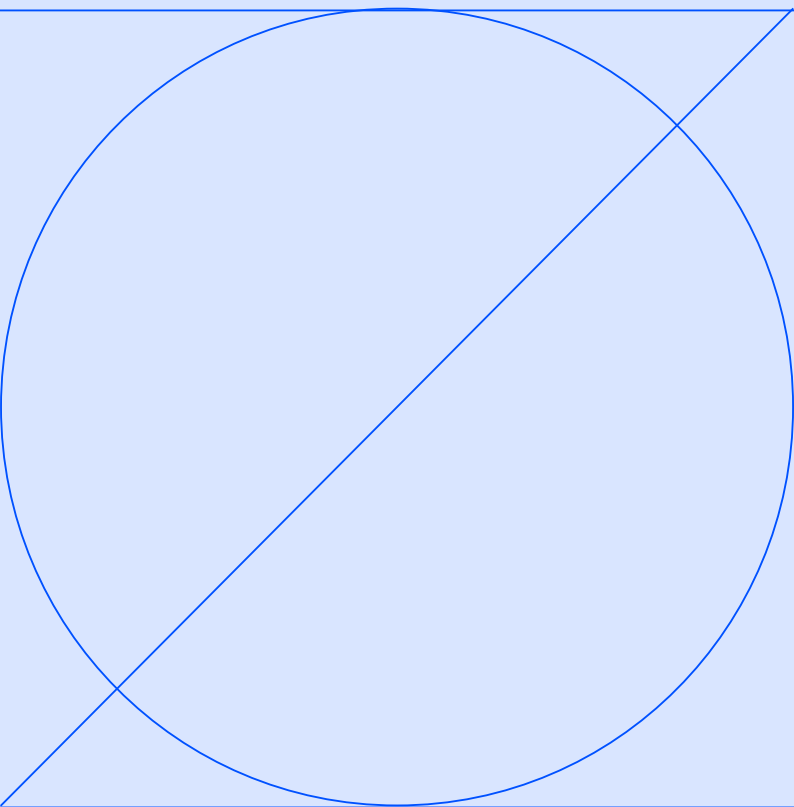

Ceilings

Plafonniers

Max

852

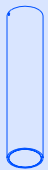

Eko

856



Cosmos

858

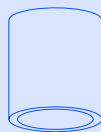

Modis

862

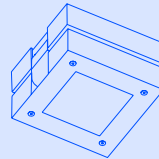

Afrodita

868

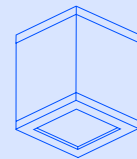

Mega

869

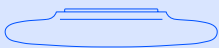

Kössel

872

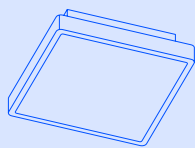

Bento IP

873

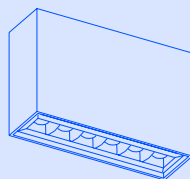

Max

Designed by LedsC4 Architectural



Spotlight
P. 540



Wall Fixture
P. 788



Downlight
P. 598



Uplight
P. 630



Bollard
P. 738



The best of interior design applied to the outdoors
Le meilleur du design intérieur appliqué à l'extérieur

Max ceiling lights are a great choice for projects requiring a single family of luminaires for both indoor and outdoor use. Thanks to a design with concealed screws, its wide range of options and advanced features, it easily adapts to the most challenging projects.

Les plafonniers Max sont particulièrement adaptés aux projets qui nécessitent une seule famille de luminaires pour l'intérieur et l'extérieur. Grâce à leur design avec vis dissimulées, leur large gamme d'options et leurs prestations élevées, ils s'adaptent facilement aux projets les plus exigeants.



14



34



DL



E3



J6



Z5



60





Max Medium Ceiling

BODY MAT AL	DIF MAT GLA		50000h L80 B20	3 MacAdam	IP 66	IK 10	UGR <16	BREEAM			
----------------	----------------	--	-------------------	--------------	----------	----------	------------	--------	--	--	--

Code example / Exemple d'élaboration d'une référence: **AI22-P3V9S10SZ5**

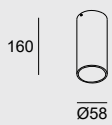
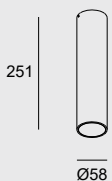
Model		W	K	CRI	Optics	Lm	Source	Finishes
AI22 - Ceiling Ø58mm 	P3V9	3.4	2700	90	S1 9°	257	OS ON-OFF 220-240V	14*
	P3W9	3.4	3000	90				34*
	P3X9	3.4	4000	90				60*
	P6P8	5.3	2200	90	S2 17°	456	OS ON-OFF 220-240V	DL*
	P6V9	5.3	2700	90	M2 27°	403		E3*
	P6W9	5.3	3000	90	F1 50°	372		J6*
	P6X9	5.3	4000	90				Z5
AI25 - Ceiling Ø58mm 	P6V9	6	2700	90	S1 9°	373	DU DALI-2 100-277V	
	P6W9	6	3000	90				
	P6X9	6	4000	90				
	P8P8	8.9	2200	80	S2 17°	498	DU DALI-2 100-277V	
	P8V9	8.9	2700	90	M2 27°	610		
	P8W9	8.9	3000	90	F1 50°	540		
	P8X9	8.9	4000	90				

Max Big Ceiling

BODY MAT AL	DIF MAT GLA		50000h L80 B20	3 MacAdam	IP 66	IK 10	UGR <19	BREEAM			
----------------	----------------	--	-------------------	--------------	----------	----------	------------	--------	--	--	--

Code example / Exemple d'élaboration d'une référence: **AT22-18V9S30SZ5**

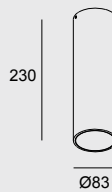
Model		W	K	CRI	Optics	Lm	Source	Finishes	
AT22 - Ceiling Ø83mm 	Constant Current								
	13V9	13.7	2700	90	S1 10°	931 - 1054	OS ON-OFF 220-240V	14*	
	13W9	13.7	3000	90			DU DALI-2 100-277V	34*	
	13X9	13.7	4000	90				60*	
	Constant Voltage								DL*
	18P8	17.3	2200	80	S3 21°	1985 - 2135	OS ON-OFF 220-240V	E3*	
	18V9	17.3	2700	90	M3 31°	2047 - 2203	DU DALI-2 100-277V	J6*	
	18W9	17.3	3000	90	F1 40°	1565 - 1812		Z5	
	18X9	17.3	4000	90					

* Please contact our sales team for conditions and delivery times.
* Consultez notre équipe commerciale pour connaître les conditions et les délais de livraison.

Max Medium





Max Big



OUTDOOR



Lens accessories
Accessoires optiques

	Wall washer diffuser (5u.) Diffuseur lèche-mur (5 u.)	71-E463-00-00	71-E464-00-00
	Honeycomb panel (5u.) Grille en nid d'abeille (5 u.)	71-E131-00-00	71-E263-00-00
	Square diffuser (5u.) Diffuseur carré (5 u.)	71-E135-00-00	71-E262-00-00
	Elliptical diffuser (5u.) Diffuseur elliptique (5 u.)	71-E141-00-00	71-E261-00-00
	Opal diffuser (5u.) Diffuseur opalin (5 u.)	71-E133-00-00	71-E260-00-00

Eko

Designed by LedsC4 Architectural



+ Eko

Spotlight
P. 550



Downlight
P. 608



Bollard
P. 744



Wall Fixtures
P. 794



An essential ceiling fixture combining functionality and design

Un plafonnier essentiel qui allie fonctionnalité et design

These fixtures provide a cost-effective solution with maximum reliability and easy maintenance. The Eko collection is ideal for projects aiming to illuminate multiple applications with a single product range.

Offrent une solution abordable, doublée d'un maximum de fiabilité et d'un entretien facile. La collection Eko est parfaite pour les projets qui visent à éclairer différents endroits avec une même collection.

2-second bulb replacement system Système de changement de lampes en 2 secondes

Ultra-fast bulb replacement during maintenance thanks to an optional accessory.

Changement ultra-rapide des ampoules lors de l'entretien grâce à un accessoire en option.

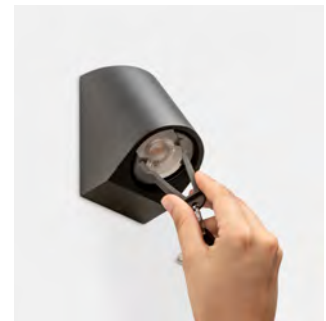

14



34



DL



E3



J6



Z5



60



Eko Ceiling

IP	BODY MAT	IK	DIF MAT	
66	AL	07	PC	

60 Z5* 14* 34* J6* E3* DL*

OUTDOOR

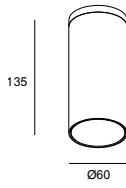

GU10	
W	Code
	60
	Z5
	J6
Max. 8	15-E064 - E3 - 37
	DL
	14
	34

* Please contact our sales team for conditions and delivery times.

* Consultez notre équipe commerciale pour connaître les conditions et les délais de livraison.

Repair accessories Accessoires de réparation



Bulb extraction kit (suction cup + clamp)
Kit d'extraction de l'ampoule (ventouse + pince)

71-E634-00-00



Venting valve reduces LED bulb overheating. La valve d'aération réduit la surchauffe des ampoules LED

Facilitates air circulation, extending the lifespan of LED bulbs.
Facilite la circulation de l'air, prolongeant ainsi la durée de vie des ampoules LED.

Cosmos

Designed by LedsC4 Architectural



+ Cosmos

Compact and stylish Compacta y elegante

The Cosmos collection is functional, technical and decorative in equal measure. Its compact and elegant design is ideal for the lighting of hotels, public areas and residences with distinct good taste.

La collection Cosmos est fonctionnelle, technique et décorative à parts égales. Son design compact et élégant est idéal pour éclairer hôtels, espaces publics et résidences de style raffiné.



Silver decorative reflector
Décorélecteur argenté

Gold decorative reflector
Décorélecteur doré

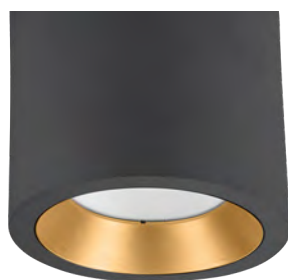

14

34

DL

E3

J6

Z5

60

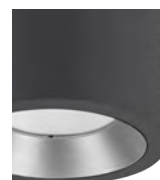
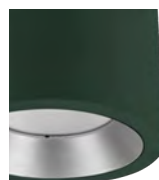



Cosmos 126mm in Son Rich Residences project in Begur. Photography: Jordi Anguera.
Cosmos 126 mm en projet, Son Rich Residences de Begur. Photographie : Jordi Anguera.

Cosmos Ceiling 90mm

BODY MAT
AL

DIF MAT
GLA



50000h
L80 B20

2
MacAdam

IP
65

IK
08

BREEAM



Z5 14* 60* 34* J6* E3* DL*

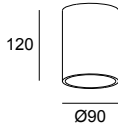

LED							
K	CRI	W Total	Real Lm	Optics	Code		
						Z5	
						J6	
						E3	
3000	80	9.5	1002	83°	15-E020 - DL - CL	ON-OFF	220-240V
						14	
						60	
						34	
						Z5	
						J6	
						E3	
4000	80	9.5	1002	83°	15-E020 - DL - CM	ON-OFF	220-240V
						14	
						60	
						34	

Cosmos Ceiling 126mm

BODY MAT
AL

DIF MAT
GLA



50000h
L80 B20

2
MacAdam

IP
66

IK
08

BREEAM



Z5 14* 60* 34* J6* E3* DL*

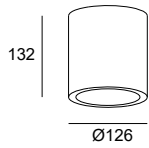

LED							
K	CRI	W Total	Real Lm	Optics	Code		
						Z5	
						J6	
						E3	
3000	80	17.6	1118	83°	15-9790 - DL - CL	ON-OFF	100-240V
						14	
						60	
						34	
						Z5	
						J6	
						E3	
4000	80	17.6	1118	83°	15-9790 - DL - CM	ON-OFF	100-240V
						14	
						60	
						34	

* Please contact our sales team for conditions and delivery times.

* Consultez notre équipe commerciale pour connaître les conditions et les délais de livraison.

**Cosmos Ceiling
168mm**

BODY MAT
AL

DIF MAT
GLA



50000h
L80 B20

2
MacAdam

IP
65

BREEAM

SEA SIDE
SUITABLE



Z5 14* 60* 34* J6* E3* DL*

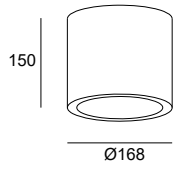

LED						
K	CRI	W Total	Real Lm	Optics	Code	
						Z5 J6 E3
3000	80	25.8	2061	90°	15-9904 - DL - CL	ON-OFF 100-240V
						14 60 34
						Z5 J6 E3
4000	80	25.8	2061	90°	15-9904 - DL - CM	ON-OFF 100-240V
						14 60 34

**Decorative accessories
Accessoires décoratifs**



Set of 2 decoreflectors (silver and gold)
Set de 2 décoréfecteurs (argent et doré)



* Please contact our sales team for conditions and delivery times.
* Consultez notre équipe commerciale pour connaître les conditions et les délais de livraison.

Modis

Designed by Luca Turrini



+ Modis

Spotlight
P. 553



Wall Fixture
P. 782

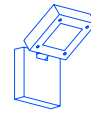

Bollard
P. 706

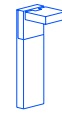

Lampost
P. 706



Total ease of movement Liberté totale de mouvement

The focused and precise lighting of the Modis ceiling light harmonises the settings in which it is located, offering the space style and class in addition to its quality, even, comfortable light. The versatility of the collection and its structural and lens options make it an ideal choice both in confined spaces and roomier settings.

L'éclairage ciblé et précis du plafonnier Modis harmonise les environnements dans lesquels il se trouve, en leur apportant non seulement du style et de la classe, mais aussi une lumière de qualité, uniforme et confortable. La polyvalence de la collection et ses options de structure et d'optiques en font un choix idéal dans les petits espaces comme dans les grands.



14 34 DL E3 J6 Z5 60





Modis Ceiling

BODY MAT AL	DIF MAT GLA		50000h L80 B20	3 MacAdam
----------------	----------------	--	-------------------	--------------

Modis Opal Single

IP 66	IK 10	SWITCH CCT 2700-3200-4000		SEA SIDE SUITABLE				
----------	----------	------------------------------	--	----------------------	--	--	--	--

Z5 14* 60* 34* J6* E3* DL*

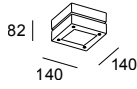
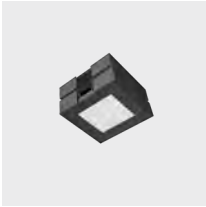

LED						
K	CRI	W Total	Real Lm	Code		
				Z5		
				J6		
				E3	OU	ON-OFF 100-277V
2700-3200-4000	80	13.2	744	05-E062	DL - DU	DALI-2 100-277V
				14	XB	CASAMBI 220-240V
				60		
				34		

The indicated flux corresponds to the core temperature.
Le flux indiqué correspond à la température centrale.

Modis Opal Double 430mm

IP 66	IK 10	BREEAM	SWITCH CCT 2700-3200-4000		SEA SIDE SUITABLE				
----------	----------	--------	------------------------------	--	----------------------	--	--	--	--

Z5 14* 60* 34* J6* E3* DL*

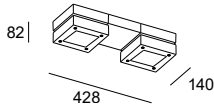

LED						
K	CRI	W Total	Real Lm	Code		
				Z5		
				J6		
				E3	OU	ON-OFF 100-277V
2700-3200-4000	80	2 × 26.4	1488	05-E063	DL - DU	DALI-2 100-277V
				14	XB	CASAMBI 220-240V
				60		
				34		

The indicated flux corresponds to the core temperature.
Le flux indiqué correspond à la température centrale.

Modis Opal Double 800mm

IP 66	IK 10	BREEAM	SWITCH CCT 2700-3200-4000		SEA SIDE SUITABLE				
----------	----------	--------	------------------------------	--	----------------------	--	--	--	--

Z5 14* 60* 34* J6* E3* DL*

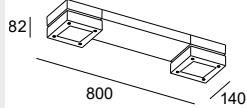

LED						
K	CRI	W Total	Real Lm	Code		
				Z5		
				J6		
				E3	OU	ON-OFF 100-277V
2700-3200-4000	80	2 × 26.4	1488	05-E064	DL - DU	DALI-2 100-277V
				14	XB	CASAMBI 220-240V
				60		
				34		

The indicated flux corresponds to the core temperature.
Le flux indiqué correspond à la température centrale.

Modis Optics Single



Code example / Exemple d'élaboration d'une référence: **AS11-18V9S30UZ5**

Model	W	K	CRI	Real Lm	Optics	Source	Finishes	
AS11 - Single ↻350° ↻180° 	18P8	18.3	2200	80	932-1062	S3 16°	OU ON-OFF 100-277V	Z5
	18V9	18.3	2700	90	1680-1914	M3 38°	DS DALI-2/PUSH 220-240V	14*
	18W9	18.3	3000	90	1680-1914	F1 48°	XB CASAMBI 220-240V	60*
	18X9	18.3	4000	90	1826-2080			34* J6* E3* DL*

Modis Optics Double 430mm

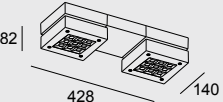

Code example / Exemple d'élaboration d'une référence: **AS12-37V9S30UZ5**

Model	W	K	CRI	Real Lm	Optics	Source	Finishes	
AS12 - Double 430mm ↻350° ↻180° 	37P8	2 × 18.3	2200	80	1864-3652	S3 16°	OU ON-OFF 100-277V	Z5
	37V9	2 × 18.3	2700	90	3360-3828	M3 38°	DS DALI-2/PUSH 220-240V	14*
	37W9	2 × 18.3	3000	90	3360-3828	F1 48°	XB CASAMBI 220-240V	60*
	37X9	2 × 18.3	4000	90	3652-4160			34* J6* E3* DL*

Modis Optics Double 800mm

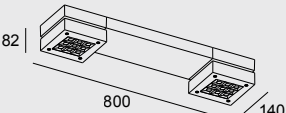

Code example / Exemple d'élaboration d'une référence: **AS13-37V9S30UZ5**

Model	W	K	CRI	Real Lm	Optics	Source	Finishes	
AS13 - Double 800mm ↻350° ↻180° 	37P8	2 × 18.3	2200	80	1864-3652	S3 16°	OU ON-OFF 100-277V	Z5
	37V9	2 × 18.3	2700	90	3360-3828	M3 38°	DS DALI-2/PUSH 220-240V	14*
	37W9	2 × 18.3	3000	90	3360-3828	F1 48°	XB CASAMBI 220-240V	60*
	37X9	2 × 18.3	4000	90	3652-4160			34* J6* E3* DL*

* Please contact our sales team for conditions and delivery times.
* Consultez notre équipe commerciale pour connaître les conditions et les délais de livraison.

Modis Opal &
Optics SingleModis Opal & Optics
Double 430mmModis Opal & Optics
Double 800mm**Lens accessories****Accessoires optiques**Visor
Visière

Z5 ●	71-E234-Z5-00	71-E234-Z5-00	71-E234-Z5-00
J6 ● *	71-E234-J6-00	71-E234-J6-00	71-E234-J6-00
E3 ● *	71-E234-E3-00	71-E234-E3-00	71-E234-E3-00
DL ● *	71-E234-DL-00	71-E234-DL-00	71-E234-DL-00
14 ○ *	71-E234-14-00	71-E234-14-00	71-E234-14-00
60 ● *	71-E234-60-00	71-E234-60-00	71-E234-60-00
34 ○ *	71-E234-34-00	71-E234-34-00	71-E234-34-00

Fixing accessories**Accessoires de fixation**235mm spiked post
Piquet de 235 mm

71-9997-05-05

-

-

Joint accessories**Accessoires de raccord**Interlinking plate
Plaque d'enchaînement

Z5 ●	-	71-E235-Z5-00	71-E235-Z5-00
J6 ● *	-	71-E235-J6-00	71-E235-J6-00
E3 ● *	-	71-E235-E3-00	71-E235-E3-00
DL ● *	-	71-E235-DL-00	71-E235-DL-00
14 ○ *	-	71-E235-14-00	71-E235-14-00
60 ● *	-	71-E235-60-00	71-E235-60-00
34 ○ *	-	71-E235-34-00	71-E235-34-00

* Please contact our sales team for conditions and delivery times.

* Consultez notre équipe commerciale pour connaître les conditions et les délais de livraison.

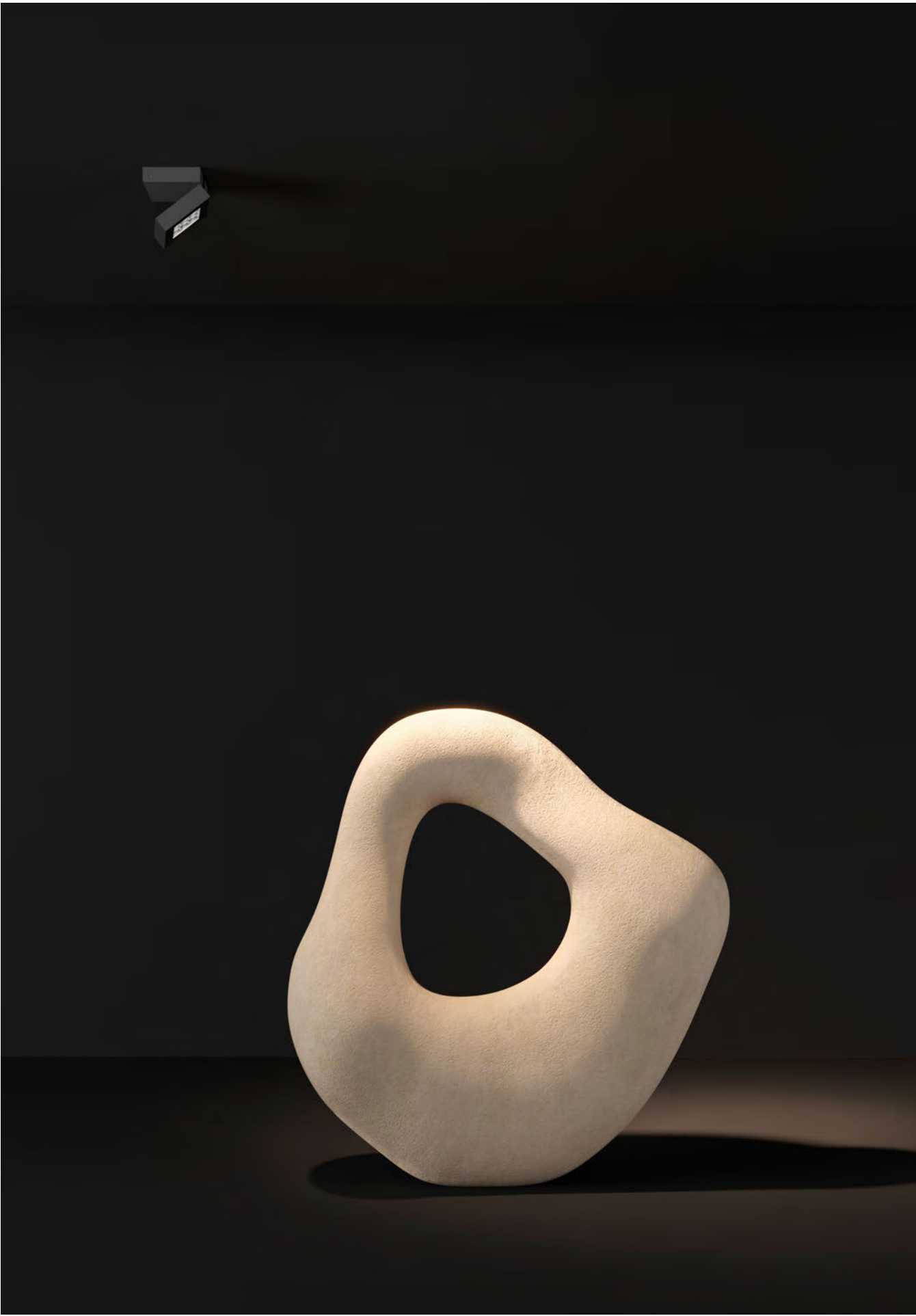



The advantages of GU10 bulb design Les avantages du design à ampoule GU10

Featuring a classic, square-shaped and functional design, Aphrodite is an essential ceiling light that easily adapts to every need, thanks to its neutral style and the advantages of its GU10 light bulb, which offers cost savings and resistance to faults. Plafonnier classique de forme carrée et au design fonctionnel. Afrodita est un essentiel qui s'adapte facilement à tous les besoins, grâce à son style neutre et aux avantages du fonctionnement par ampoule GU10, qui permet d'économiser sur le projet et d'éviter les pannes.

Afrodita GU10

BODY MAT	DIF MAT		IP	IK	SEA SIDE SUITABLE
AL	GLA		54	05	

● ○ ●
Z5 14 34

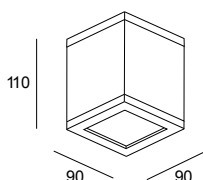

GU10	
W	Code
Max. 8	Z5
	15-9480 - 14 - 37
	34



Large size for large areas Grande taille pour les grandes surfaces

Mega's large size, with a base measuring up to 1.2 metres in diameter, is ideal for illuminating very large indoor and outdoor settings. Its advanced features and timeless design make it an ideal choice for professional and domestic projects requiring both elegance and quality. La grande taille de Mega, dont la base peut atteindre 1,2 mètre de diamètre, s'avère idéale pour éclairer de très vastes espaces, en intérieur comme en extérieur. Ses hautes prestations et le design intemporel de la collection en font une option idéale pour les projets professionnels et domestiques qui exigent élégance et qualité à parts égales.





BODY MAT	DIF MAT		50000h	3	IP
AL	PLABS		L80 B20	MacAdam	65

Mega Ceiling 800mm

IK	UGR	LOW	BREEAM	SWITCH CCT		SEA SIDE	LED	DRIVER	DALI
10	<16	FLICKER		3000-4000		SUITABLE			

M1

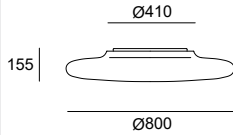

LED						
K	CRI	W Total	Real Lm	Code		
3000-4000	80	81.4	8062	15-E110 - M1 - EH	DALI 100-277V	

The indicated flow corresponds to the temperature 3000 K
Le flux indiqué correspond à la température 3 000 K

Mega Ceiling 1200mm

IK	UGR	LOW	BREEAM	SWITCH CCT		SEA SIDE	LED	DRIVER	DALI
10	<16	FLICKER		3000-4000		SUITABLE			

M1

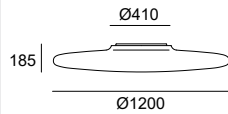

LED						
K	CRI	W Total	Real Lm	Code		
3000-4000	80	81.4	8303	15-E111 - M1 - EH	DALI 100-277V	

The indicated flow corresponds to the temperature 3000 K
Le flux indiqué correspond à la température 3 000 K

Connective controllers Contrôleurs connectés

P. 969



Consult the available control systems / Consultez les systèmes de contrôle disponibles:
DALI2 / DALI2
Bluetooth wireless / Sans fil Bluetooth
Autonomous / Autonome



Resistant and timeless Résistant et intemporel

Featuring a classic, timeless design, this collection of ceiling lights emits direct light and easily withstands the most extreme installation conditions thanks to its sturdy square shape with slightly rounded edges.

De ligne classique et intemporelle, cette collection de plafonniers projette une lumière directe et s'adapte facilement, grâce à sa forme carrée robuste légèrement arrondie sur les bords, aux conditions de résistance les plus extrêmes.

Kössel 300mm

BODY MAT PC+ABS	DIF MAT PC		IP 66	IK 10	SEA SIDE SUITABLE		
--------------------	---------------	--	----------	----------	----------------------	--	--

34

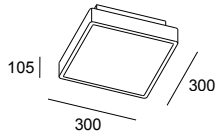

E27	
W 2 × Max. 15	Code 15-9619 - 34 - M1

Kössel 400mm

BODY MAT PC+ABS	DIF MAT PC		IP 66	IK 10	UGR <16	BREEAM	50000h L80 B20	3 MacAdam	SEA SIDE SUITABLE		
--------------------	---------------	--	----------	----------	------------	--------	-------------------	--------------	----------------------	--	--

34

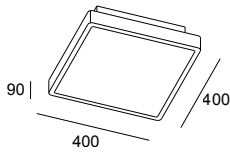

LED					
K 3000	CRI 80	W Total 20.1	Real Lm 1172	Code 15-9806 - 34 - CL	ON-OFF 100-240V

Bento IP66

Designed by LedsC4 Architectural

OUTDOOR



Lens system designed with high-definition micro-reflectors that conceal the light source

Système optique conçu avec des micro-réflecteurs haute définition qui masquent la source lumineuse

The lenses in this collection of downlights are specially developed to avoid glares and achieve optimal control of the luminaire in demanding situations. Featuring a multi-cell structure and individual lens modules, Bento is the ideal choice for environments where comfort and integration are the foremost concern.

Le groupe optique de cette collection de downlights est spécialement conçu pour éviter l'éblouissement et obtenir un contrôle optimal du luminaire dans les situations exigeantes. Avec sa structure multicellulaire et ses modules optiques individuels, Bento est l'option idéale pour les environnements qui nécessitent un maximum de confort et d'intégration.

Full IP66 protection, which means the luminaire can be installed in damp spaces or those that are exposed to dust and water.

Protection IP66 complète qui permet d'installer le luminaire dans des espaces humides ou exposés à la poussière et à l'eau.

Bento Surface 6 LEDS IP66

BODY MAT	50000h	3	IP	IK	UGR	DIF MAT			
AL	L80 B20	MacAdam	66	09	<13	GLA			

14 60 34* J6* E3* DL* Z5*

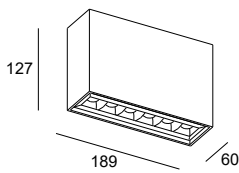

LED									
K	CRI	W Total	Real Lm	Optics	Code				
						14			
						60			
2700	90	14.7	1119	18°	15-A116	34	OU	ON-OFF 100-277V	
2700	90	14.7	1276	38°	15-A117	J6	DS	DALI-2 220-240V	
2700	90	14.7	1205	47°	15-A118	E3			
						DL			
						Z5			
						14			
						60			
3000	90	14.7	1119	18°	15-A119	34	OU	ON-OFF 100-277V	
3000	90	14.7	1276	38°	15-A120	J6	DS	DALI-2 220-240V	
3000	90	14.7	1205	47°	15-A121	E3			
						DL			
						Z5			
						14			
						60			
4000	90	14.7	1216	18°	15-A122	34	OU	ON-OFF 100-277V	
4000	90	14.7	1387	38°	15-A123	J6	DS	DALI-2 220-240V	
4000	90	14.7	1310	47°	15-A124	E3			
						DL			
						Z5			

* Please contact our sales team for conditions and delivery times.

* Consultez notre équipe commerciale pour connaître les conditions et les délais de livraison.

CEILING | PLAFONNIERS

Chillout

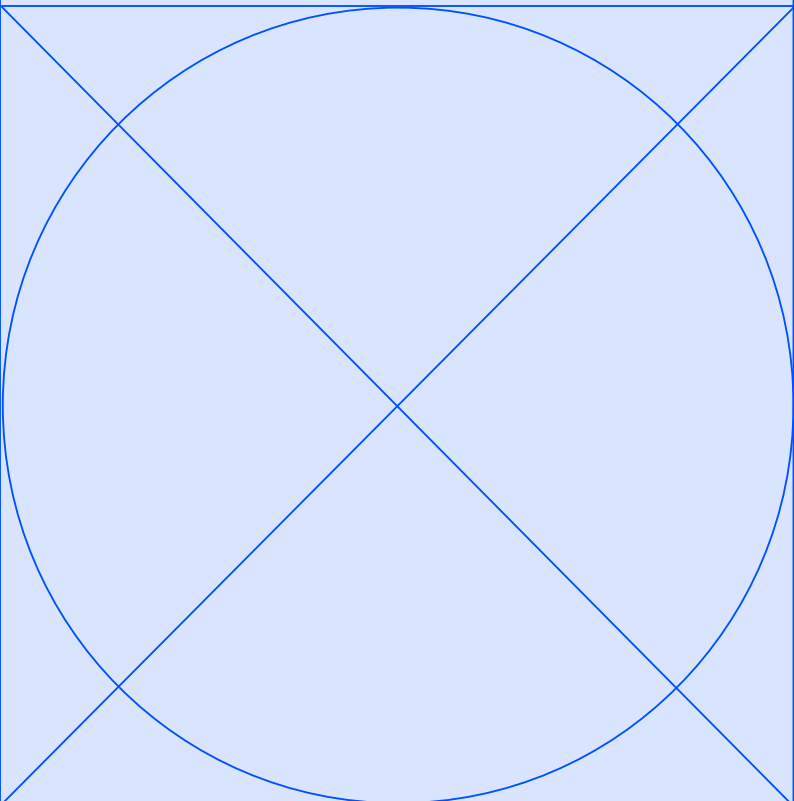

Sinia

876



Orbit

884



Rack

892

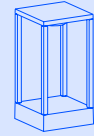

Moal

904

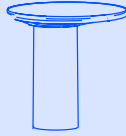

Barcino

907

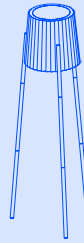

Cisne

910

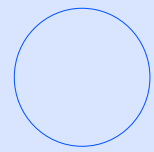

Sinia

Designed by Artec Studio



+ Sinia



Natural elegance and inviting lighting Élégance naturelle et éclairage accueillant

Lightweight and unobtrusive, Sinia radiates natural elegance and warmth, making it inherently distinctive. During the day, it seamlessly merges with the landscape like a silent sculpture with its subtle and slender profile. At night, it casts a warm glow that complements the landscape's intent, effortlessly adapting to its surroundings.

Aérien et discret, le luminaire Sinia arbore une élégance naturelle et accueillante qui lui confère une distinction innée. Subtile et élancé de jour, il se fond dans le paysage tel une sculpture silencieuse, tandis que de nuit il assure un éclairage très chaleureux, accompagnant le paysage et s'y adaptant avec aisance.

Spike
Piquet

Fixed
Fixée

Portable
Portable







With its understated and integrated design, this collection is designed to harmonise with urban terraces and enhance gardens by emitting a warm and welcoming light.

Arborant une structure subtile et intégrée, la collection est conçue pour harmoniser les terrasses urbaines ainsi que pour embellir les jardins avec son effet d'éclairage chaud.



Enhanced visual comfort Plus de confort visuel

As an alternative to decorative glass, Sinia features an additional component to provide heightened visual comfort, effectively preventing glare.

En alternative au verre décoratif, Sinia dispose d'un composant supplémentaire qui apporte un plus de confort visuel, évitant ainsi l'éblouissement.



Customisation options Possibilité de personnalisation

Standard finishes are available in black and brown, with the option for custom finishes upon request to seamlessly blend with your surroundings.

Finitions standard noir et marron, avec possibilité de personnalisation sur demande pour une adaptation plus harmonieuse à l'environnement.



Elegance and posture Élégance et posture

Sinia boasts a distinctive posture thanks to the subtle curvature of its structure before it reaches the diffuser, giving it a slim and distinguished appearance that sets it apart from the rest.

Sinia arbore une posture particulière grâce à la subtile courbure de sa structure en amont du diffuseur, lui conférant ainsi une silhouette élancée qui sort du lot.



Sinia 600mm

IP	IK	BODY MAT	DIF MAT		SEA SIDE SUITABLE
65	05	AL,PLABS	PC	1.5 m	

60 J6

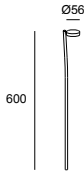

LED					3V/max. 1200mA
K	CRI	W	Real Lm	Code	
2700	90	3.4	192	10-E033 - J6 - CK	60

Sinia 800mm

IP	IK	BODY MAT	DIF MAT		SEA SIDE SUITABLE
65	05	AL,PLABS	PC	1.5 m	

60 J6

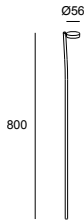

LED					3V/max. 1200mA
K	CRI	W	Real Lm	Code	
2700	90	3.4	192	10-E030 - J6 - CK	60

Sinia 1000mm

IP	IK	BODY MAT	DIF MAT		SEA SIDE SUITABLE
65	05	AL,PLABS	PC	1.5 m	

60 J6

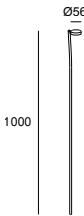
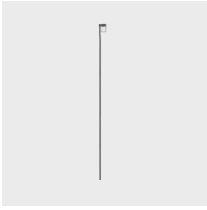

LED					3V/max. 1200mA
K	CRI	W	Real Lm	Code	
2700	90	3.4	192	10-E031 - J6 - CK	60

Sinia 1200mm

IP	IK	BODY MAT	DIF MAT		SEA SIDE SUITABLE
65	05	AL,PLABS	PC	1.5 m	

60 J6

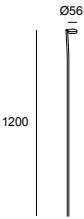
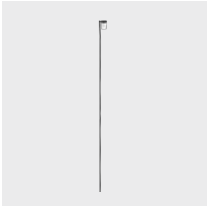



LED					3V/max. 1200mA
K	CRI	W	Real Lm	Code	
2700	90	3.4	192	10-E032 - J6 - CK	60









Lens accessories

Accessoires optiques

	Glass Diffuser Diffuseur en verre			71-E656-37-F9
	Comfort Visor Visière Confort	60 ●		71-E657-60-00
		J6 ●		71-E657-J6-00

Fixing accessories

Accessoires de fixation

	Spiked post Piquet			71-E649-60-OU
	Fixed base 1 body (with driver included) Base fixe 1 corps (avec driver fourni)	60 ●		71-E650-60-OU
		J6 ●		71-E650-J6-OU
	Fixed base 2 bodies (with driver included) Base fixe 2 corps (avec driver fourni)	60 ●		71-E651-60-OU
		J6 ●		71-E651-J6-OU
	Fixed base 3 bodies (with driver included) Base fixe 3 corps (avec driver fourni)	60 ●		71-E652-60-OU
		J6 ●		71-E652-J6-OU
	Portatil Base 1 Body (with driver included) Base portable 1 corps (avec driver fourni)	60 ●		71-E653-60-OU
		J6 ●		71-E653-J6-OU
	Portatil Base 2 Bodies (with driver included) Base portable 2 corps (avec driver fourni)	60 ●		71-E654-60-OU
		J6 ●		71-E654-J6-OU
	Portatil Base 3 Bodies (with driver included) Base portable 3 corps (avec driver fourni)	60 ●		71-E655-60-OU
		J6 ●		71-E655-J6-OU

Orbit

Designed by Luca Turrini



+ Orbit

Bollard
P. 718



Lamppost
P. 718



Illuminating accompanied Éclairer en accompagnant

Orbit is the ideal choice for creating warm environments in areas where lighting is the key to success when it comes to connecting with customers and users. Featuring soft shapes and various choices of finishes and light beam directions, Orbit's mere presence grants a distinct touch of quality to the space it inhabits. Orbit est un choix idéal pour créer des environnements chaleureux dans des zones où l'éclairage est la clé du succès pour entrer en contact avec les clients et les utilisateurs. Avec ses formes douces et ses différentes options de finitions et de directions du faisceau lumineux, Orbit apporte par sa présence un supplément de qualité à l'espace qu'elle habite.

300 mm

1060 mm

1800 mm



14

34

DL

E3

J6

Z5

60





Light options at the top of the head: signage point, zero light pollution and soft upward light.
Options d'éclairage dans la partie supérieure de la tête: point de signalisation, pollution lumineuse nulle et lumière douce vers le haut.



Concealed table mounting.
Fixation cachée pour table.

BODY MAT	DIF MAT	50000h	3
AL	PC	L80 B20	MacAdam

Orbit Table Lamp Rechargeable Covered

IP	IK	III	BREEAM	SEA SIDE SUITABLE	LED	DRIVER	DIM
65	10						

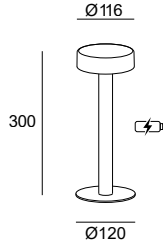

6H → 100% 6H 50% 12H 10% 60H Z5 14* 60* 34* J6* E3* DL*

LED						
K	CRI	W Total	Real Lm	Code		
2700	80	1.5	108	10-E019	- DL - CK	TOUCH DIMMING 5VDC 1000mA
					Z5 J6 E3 14 60 34	
3000	80	1.5	108	10-E019	- DL - CL	TOUCH DIMMING 5VDC 1000mA
					Z5 J6 E3 14 60 34	
4000	80	1.5	108	10-E019	- DL - CM	TOUCH DIMMING 5VDC 1000mA
					Z5 J6 E3 14 60 34	

Orbit Table Lamp Rechargeable Small Hole Cover

IP	IK	III	BREEAM	SEA SIDE SUITABLE	LED	DRIVER	DIM
65	10						

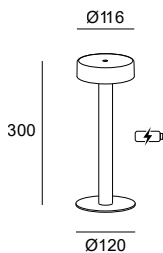

6H → 100% 6H 50% 12H 10% 60H Z5 14* 60* 34* J6* E3* DL*

LED						
K	CRI	W Total	Real Lm	Code		
2700	80	1.5	109	10-E020	- DL - CK	TOUCH DIMMING 5VDC 1000mA
					Z5 J6 E3 14 60 34	
3000	80	1.5	109	10-E020	- DL - CL	TOUCH DIMMING 5VDC 1000mA
					Z5 J6 E3 14 60 34	
4000	80	1.5	109	10-E020	- DL - CM	TOUCH DIMMING 5VDC 1000mA
					Z5 J6 E3 14 60 34	

*Please contact our sales team for conditions and delivery times.

*Consultez notre équipe commerciale pour connaître les conditions et les délais de livraison.

Orbit Table Lamp
Rechargeable Big Hole Cover

IP 65	IK 10		BREEAM	SEA SIDE SUITABLE			
----------	----------	--	--------	----------------------	--	--	--

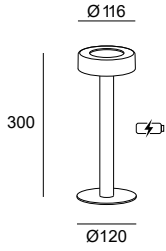

6H → 100% 6H 50% 12H 10% 60H

Z5 14* 60* 34* J6* E3* DL*

LED							
K	CRI	W Total	Real Lm	Code			
2700	80	1.5	118	10-E021	- DL - CK	Z5 J6 E3 14 60 34	TOUCH DIMMING 5VDC 1000mA
3000	80	1.5	118	10-E021	- DL - CL	Z5 J6 E3 14 60 34	TOUCH DIMMING 5VDC 1000mA
4000	80	1.5	118	10-E021	- DL - CM	Z5 J6 E3 14 60 34	TOUCH DIMMING 5VDC 1000mA

Fixing accessories

Accessoires de fixation

	235mm spiked post Piquet de 235 mm	71-9997-05-05
	Anti-pulling kit Kit de sécurité anti-arrachement	71-E293-00-00
	Fixing for table Fixation pour table	71-E458-60-60

Connection accessories

Accessoires de connexion

	Individual charger Chargeur individuel	71-E367-60-00
	Multiple charger Chargeur multiple	71-8332-05-00

* Please contact our sales team for conditions and delivery times.
* Consultez notre équipe commerciale pour connaître les conditions et les délais de livraison.

BODY MAT	DIF MAT	50000h	3
AL	PC	L80 B20	MacAdam

Orbit Floor Lamp Rechargeable Covered

IP	IK	III	BREEAM	SEA SIDE SUITABLE	LED	DRIVER	DIM
65	10						

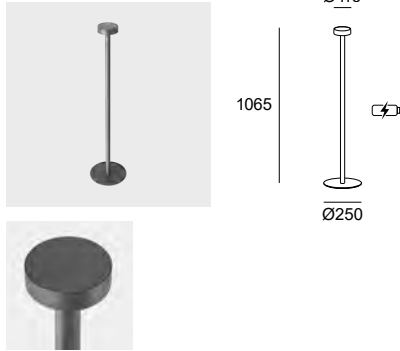

6H → 100% 6H 50% 12H 10% 60H Z5 14* 60* 34* J6* E3* DL*

LED							
K	CRI	W Total	Real Lm	Code			
2700	80	1.5	108	25-E018	- DL - CK	TOUCH DIMMING 5VDC 1000mA	Z5 J6 E3 14 60 34
3000	80	1.5	108	25-E018	- DL - CL	TOUCH DIMMING 5VDC 1000mA	Z5 J6 E3 14 60 34
4000	80	1.5	108	25-E018	- DL - CM	TOUCH DIMMING 5VDC 1000mA	Z5 J6 E3 14 60 34

Orbit Floor Lamp Rechargeable Small Hole Cover

IP	IK	III	BREEAM	SEA SIDE SUITABLE	LED	DRIVER	DIM
65	10						

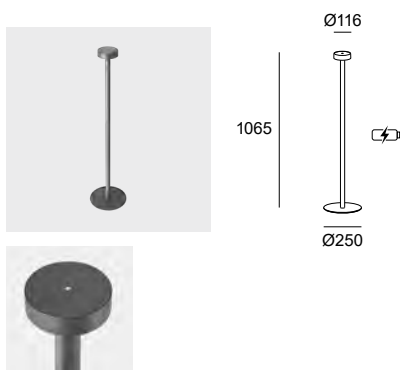

6H → 100% 6H 50% 12H 10% 60H Z5 14* 60* 34* J6* E3* DL*

LED							
K	CRI	W Total	Real Lm	Code			
2700	80	1.5	109	25-E019	- DL - CK	TOUCH DIMMING 5VDC 1000mA	Z5 J6 E3 14 60 34
3000	80	1.5	109	25-E019	- DL - CL	TOUCH DIMMING 5VDC 1000mA	Z5 J6 E3 14 60 34
4000	80	1.5	109	25-E019	- DL - CM	TOUCH DIMMING 5VDC 1000mA	Z5 J6 E3 14 60 34

Orbit Floor Lamp
Rechargeable Big Hole Cover

IP
65

IK
10

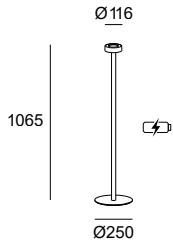

6H → 100% 6H 50% 12H 10% 60H

Z5 14* 60* 34* J6* E3* DL*

LED						
K	CRI	W Total	Real Lm	Code		
2700	80	1.5	118	25-E020	- DL - CK	Z5 J6 E3 TOUCH DIMMING 5VDC 1000mA
					14 60 34	
3000	80	1.5	118	25-E020	- DL - CL	Z5 J6 E3 TOUCH DIMMING 5VDC 1000mA
					14 60 34	
4000	80	1.5	118	25-E020	- DL - CM	Z5 J6 E3 TOUCH DIMMING 5VDC 1000mA
					14 60 34	

Fixing accessories
Accessoires de fixation



235mm spiked post
Piquet de 235 mm

71-9997-05-05

Orbit Floor Lamp Plug&Play Covered

IP 66	IK 10		BREEAM	SWITCH CCT 2700-3200-4000		SEA SIDE SUITABLE	LED	DRIVER	DIM
----------	----------	--	--------	------------------------------	--	----------------------	-----	--------	-----

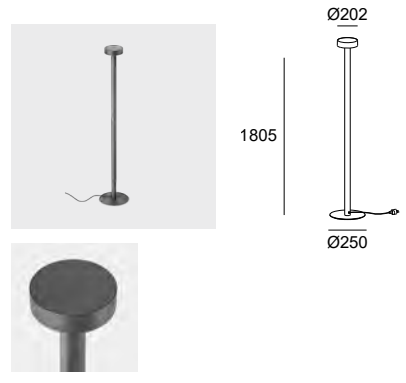

LED						
K	CRI	W Total	Real Lm	Code		
					Z5	
					J6	
					E3	
2700-3200-4000	80	11.5	761	25-E021	- DL - EH	ON-OFF 100-240V
					14	
					60	
					34	

The indicated flux corresponds to the core temperature.
Le flux indiqué correspond à la température centrale.

Orbit Floor Lamp Plug&Play Small Hole Cover

IP 66	IK 10		BREEAM	SWITCH CCT 2700-3200-4000		SEA SIDE SUITABLE	LED	DRIVER	DIM
----------	----------	--	--------	------------------------------	--	----------------------	-----	--------	-----

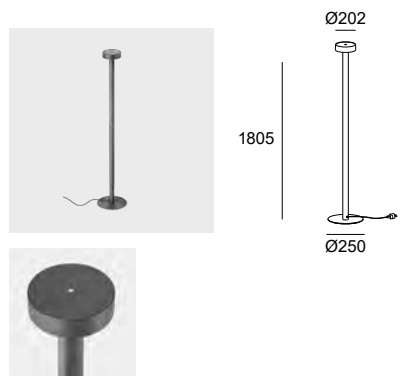

LED						
K	CRI	W Total	Real Lm	Code		
					Z5	
					J6	
					E3	
2700-3200-4000	80	11.5	764	25-E022	- DL - EH	ON-OFF 100-240V
					14	
					60	
					34	

The indicated flux corresponds to the core temperature.
Le flux indiqué correspond à la température centrale.

Orbit Floor Lamp Plug&Play Big Hole Cover

IP 66	IK 10		BREEAM	SWITCH CCT 2700-3200-4000		SEA SIDE SUITABLE	LED	DRIVER	DIM
----------	----------	--	--------	------------------------------	--	----------------------	-----	--------	-----

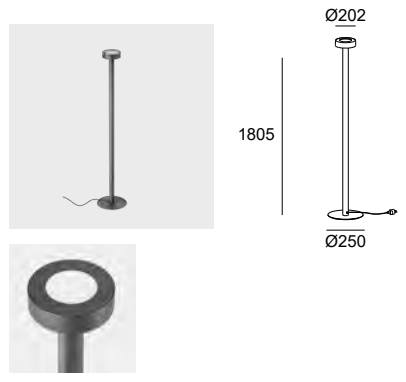

LED						
K	CRI	W Total	Real Lm	Code		
					Z5	
					J6	
					E3	
2700-3200-4000	80	11.5	858	25-E023	- DL - EH	ON-OFF 100-240V
					14	
					60	
					34	

The indicated flux corresponds to the core temperature.
Le flux indiqué correspond à la température centrale.

* Please contact our sales team for conditions and delivery times.
* Consultez notre équipe commerciale pour connaître les conditions et les délais de livraison.

Rack

Designed by Luca Turrini

Wall Fixture
P. 823



Maximum flexibility for superior adaptation to spaces
Flexibilité maximale pour une meilleure adaptation aux espaces

Rack has been painstakingly developed for those projects where lighting and decorating with personality is not enough, but reliability is an equal or even more important factor. This collection has advanced performance features such as an IP66 rating, DALI lighting control, BREEAM efficiency or a treatment for coastal conditions.

RACK a été minutieusement développée pour les projets où un éclairage et une décoration avec de la personnalité ne suffisent pas, mais où la fiabilité est un facteur égal, voire plus important. Cette collection propose des prestations élevées telles que la protection IP66, la variation DALI, l'efficacité BREEAM ou le traitement contre l'atmosphère marine.



14

34

DL

E3

J6

Z5

60







Rack Rechargeable 100×100×270mm

IP 65	IK 10		BREEAM	SEA SIDE SUITABLE	LED	DRIVER
----------	----------	--	--------	----------------------	-----	--------

6H → 100% 6H 50% 12H 10% 60H Z5 14* 60 34* J6* E3* DL*

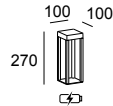

10-E001 10-E002 10-E003

LED					
K	CRI	W Total	Real Lm	Code	
2700	80	1.5	88	Z5	
				J6	
				10-E001 E3	
				10-E002 - DL - CK	
3000	80	1.5	88	Z5	
				J6	
				10-E001 E3	
				10-E002 - DL - CL	
4000	80	1.5	88	Z5	
				J6	
				10-E001 E3	
				10-E002 - DL - CM	
				14	
				60	
				34	

Rack Rechargeable 150×150×300mm

IP 66	IK 06		BREEAM	SWITCH CCT 2700-3200-4000	SEA SIDE SUITABLE	LED	DRIVER
----------	----------	--	--------	------------------------------	----------------------	-----	--------

13H → 100% 12H 50% 30H 10% 100H Z5 14* 60 34* J6* E3* DL*

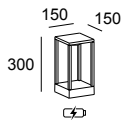

10-E010 10-E011 10-E012

LED					
K	CRI	W Total	Real Lm	Code	
2700-3200-4000	80	3	174	Z5	
				J6	
				10-E010 E3	
				10-E011 - DL - EH	
				14	
				60	
				34	

* Please contact our sales team for conditions and delivery times.
* Consultez notre équipe commerciale pour connaître les conditions et les délais de livraison.

Rack Rechargeable
260×260×300mm

IP 66	IK 06		BREEAM	SWITCH CCT 2700-3200-4000	SEA SIDE SUITABLE		
----------	----------	--	--------	------------------------------	----------------------	--	--

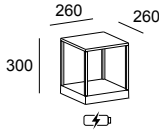

10-E014 10-E015 10-E017

13H → 100% 12H 50% 30H 10% 100H Z5 14* 60 34* J6* E3* DL*

LED					
K	CRI	W Total	Real Lm	Code	
2700-3200-4000	80	3	174	Z5	
				J6	
				E3	
				10-E014	- DL - EH
				10-E015	14
				10-E017	60
					34

The indicated flux corresponds to the core temperature.
Le flux indiqué correspond à la température centrale.

Rack Rechargeable
150×150×700mm

IP 66	IK 06		BREEAM	SWITCH CCT 2700-3200-4000	SEA SIDE SUITABLE		
----------	----------	--	--------	------------------------------	----------------------	--	--

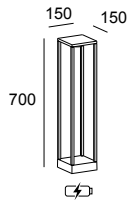

25-E009 25-E010 25-E011

13H → 100% 12H 50% 30H 10% 100H Z5 14* 60 34* J6* E3* DL*

LED					
K	CRI	W Total	Real Lm	Code	
2700-3200-4000	80	3	174	Z5	
				J6	
				E3	
				25-E009	- DL - EH
				25-E010	14
				25-E011	60
					34

The indicated flux corresponds to the core temperature.
Le flux indiqué correspond à la température centrale.

Rack Rechargeable
260×260×900mm

IP 66	IK 06		BREEAM	SWITCH CCT 2700-3200-4000	SEA SIDE SUITABLE		
----------	----------	--	--------	------------------------------	----------------------	--	--

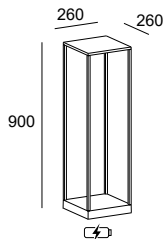





25-E012 25-E013 25-E014

13H → 100% 12H 50% 30H 10% 100H Z5 14* 60 34* J6* E3* DL*

LED					
K	CRI	W Total	Real Lm	Code	
2700-3200-4000	80	3	174	Z5	
				J6	
				E3	
				25-E012	- DL - EH
				25-E013	14
				25-E014	60
					34



The indicated flux corresponds to the core temperature.
Le flux indiqué correspond à la température centrale.

Rack Rechargeable 100×100×270mm	Rack Rechargeable 150×150×300mm	Rack Rechargeable 260×260×300mm	Rack Rechargeable 150×150×700mm	Rack Rechargeable 260×260×900mm
				



Lens accessories
Accessoires optiques

	Spherical opal glass diffuser Diffuseur sphérique en verre opalin	-	71-E284-60-F9	71-E284-60-F9	71-E284-60-F9	71-E284-60-F9
-----------------------------------------------------------------------------------	----------------------------------------------------------------------	---	---------------	---------------	---------------	---------------

Fixing accessories
Accessoires de fixation

	Spiked post Piquet	-	71-E357-60-00	71-E358-60-00	71-E357-60-00	71-E358-60-00
	4 wheels kit Kit 4 roulettes	-	-	71-E292-60-00	-	71-E292-60-00
	Anti-pulling kit Kit de sécurité anti-arrachement	71-E293-00-00	71-E293-00-00	71-E293-00-00	71-E293-00-00	71-E293-00-00

Connection accessories
Accessoires de connexion

	Individual charger Chargeur individuel	71-E367-60-00	71-E367-60-00	71-E367-60-00	71-E367-60-00	71-E367-60-00
	Multiple charger Chargeur multiple	71-8332-05-00	71-8332-05-00	71-8332-05-00	71-8332-05-00	71-8332-05-00

Decorative accessories
Accessoires décoratifs

	Decorative grids set (4u.) Set de grilles décoratives (4 u.)	60 ●	71-E294-60-00	71-E279-60-00	71-E281-60-00	71-E280-60-00	71-E282-60-00
		Z5 ● *	71-E294-Z5-00	71-E279-Z5-00	71-E281-Z5-00	71-E280-Z5-00	71-E282-Z5-00
		J6 ● *	71-E294-J6-00	71-E279-J6-00	71-E281-J6-00	71-E280-J6-00	71-E282-J6-00
		E3 ● *	71-E294-E3-00	71-E279-E3-00	71-E281-E3-00	71-E280-E3-00	71-E282-E3-00
		DL ● *	71-E294-DL-00	71-E279-DL-00	71-E281-DL-00	71-E280-DL-00	71-E282-DL-00
		14 ○ *	71-E294-14-00	71-E279-14-00	71-E281-14-00	71-E280-14-00	71-E282-14-00
		34 ○ *	71-E294-34-00	71-E279-34-00	71-E281-34-00	71-E280-34-00	71-E282-34-00

Rack Plug&Play

BODY MAT	DIF MAT	50000h	3
AL.CON	GLA	L80 B20	MacAdam

Rack Plug&Play 150x150x160mm

IP	IK		BREEAM	SWITCH CCT		SEA SIDE SUITABLE		
66	06			2700-3200-4000	2.5 m			

Z5 14* 60 34* J6* E3* DL*

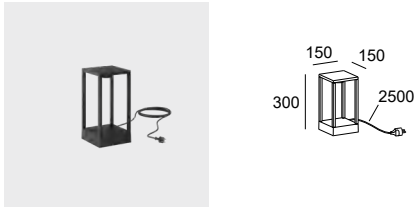

10-E004 10-E005 10-E006

LED							
K	CRI	W Total	Real Lm	Code			
					Z5		
					J6		
				10-E004	E3		
2700-3200-4000	80	14.9	760	10-E005	- DL -	OU ON-OFF 100-277V	
				10-E006	14	XB CASAMBI 220-240V	
					60		
					34		

The indicated flux corresponds to the core temperature.
Le flux indiqué correspond à la température centrale.

Rack Plug&Play 260x260x300mm

IP	IK		BREEAM	SWITCH CCT		SEA SIDE SUITABLE		
66	06			2700-3200-4000	2.5 m			

Z5 14* 60 34* J6* E3* DL*

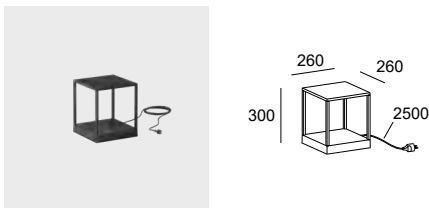

10-E007 10-E008 10-E009

LED							
K	CRI	W Total	Real Lm	Code			
					Z5		
					J6		
				10-E007	E3		
2700-3200-4000	80	14.9	760	10-E008	- DL -	OU ON-OFF 100-277V	
				10-E009	14	XB CASAMBI 220-240V	
					60		
					34		

The indicated flux corresponds to the core temperature.
Le flux indiqué correspond à la température centrale.

Rack Plug&Play 150x150x700mm

IP	IK		BREEAM	SWITCH CCT		SEA SIDE SUITABLE		
66	06			2700-3200-4000	2.5 m			

Z5 14* 60 34* J6* E3* DL*

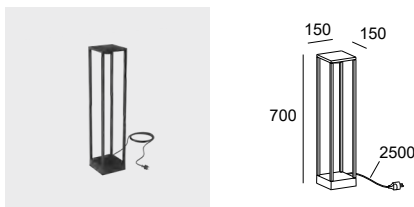

25-E006 25-E007 25-E008

LED							
K	CRI	W Total	Real Lm	Code			
					Z5		
					J6		
				25-E006	E3		
2700-3200-4000	80	14.9	760	25-E007	- DL -	OU ON-OFF 100-277V	
				25-E008	14	XB CASAMBI 220-240V	
					60		
					34		

The indicated flux corresponds to the core temperature.
Le flux indiqué correspond à la température centrale.

* Please contact our sales team for conditions and delivery times.
* Consultez notre équipe commerciale pour connaître les conditions et les délais de livraison.

Rack Plug&Play 260×260×900mm

IP
66

IK
06



BREEAM

SWITCH CCT
2700-3200-4000

2.5 m

SEA SIDE
SUITABLE



OUTDOOR

Z5 14* 60 34* J6* E3* DL*

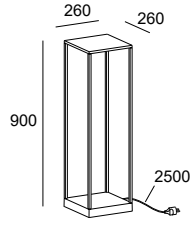

25-E000

25-E001

25-E002

LED						
K	CRI	W Total	Real Lm	Code		
					Z5	
					J6	
				25-E000	E3	
2700-3200-4000	80	14.9	760	25-E001 - DL	OU	ON-OFF 100-277V
				25-E002	XB	CASAMBI 220-240V ⚡
					14	
					60	
					34	

The indicated flux corresponds to the core temperature.
Le flux indiqué correspond à la température centrale.

Rack Plug&Play 150×150×160mm



Rack Plug&Play 260×260×300mm



Rack Plug&Play 150×150×700mm



Rack Plug&Play 260×260×900mm



Lens accessories Accessoires optiques



Spherical opal glass diffuser
Diffuseur sphérique en verre opalin

71-E284-60-F9

71-E284-60-F9

71-E284-60-F9

71-E284-60-F9

Fixing accessories Accessoires de fixation



Spiked post
Piquet

71-E357-60-00

71-E358-60-00

71-E357-60-00

71-E358-60-00



4 wheels kit
Kit 4 roulettes

-

71-E292-60-00

-

71-E292-60-00

Decorative accessories Accessoires décoratifs



Decorative grids set (4u.)
Set de grilles décoratives (4 u.)

Z5 ●

71-E279-Z5-00

71-E281-Z5-00

71-E280-Z5-00

71-E282-Z5-00

J6 ●

71-E279-J6-00

71-E281-J6-00

71-E280-J6-00

71-E282-J6-00

E3 ●

71-E279-E3-00

71-E281-E3-00

71-E280-E3-00

71-E282-E3-00

DL ●

71-E279-DL-00

71-E281-DL-00

71-E280-DL-00

71-E282-DL-00

14 ○

71-E279-14-00

71-E281-14-00

71-E280-14-00

71-E282-14-00

60 ●

71-E279-60-00

71-E281-60-00

71-E280-60-00

71-E282-60-00

34 ○

71-E279-34-00

71-E281-34-00

71-E280-34-00

71-E282-34-00

CHILLOUT

Rack Bollard

BODY MAT	DIF MAT	50000h	3
AL.CON	GLA	L80 B20	MacAdam

Rack Bollard Fixed 150×150×300mm

IP	IK		BREEAM	SWITCH CCT		SEA SIDE		
66	06			2700-3200-4000	2 m	SUITABLE		

Z5 14* 60 34* J6* E3* DL*



55-E057 55-E058 55-E059

LED								
K	CRI	W Total	Real Lm	Code				
				Z5				
				J6				
				55-E057 E3 OU	ON-OFF	100-277V		
2700-3200-4000	80	14.9	760	55-E058 - DL - DU	DALI-2	100-277V		
				55-E059 14 XB	CASAMBI	220-240V		
				60				
				34				

The indicated flux corresponds to the core temperature.
Le flux indiqué correspond à la température centrale.

Rack Bollard Fixed 260×260×300mm

IP	IK		BREEAM	SWITCH CCT		SEA SIDE		
66	06			2700-3200-4000	2 m	SUITABLE		

Z5 14* 60 34* J6* E3* DL*

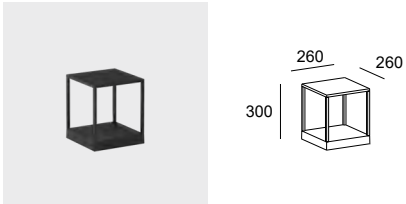

55-E063 55-E064 55-E065

LED								
K	CRI	W Total	Real Lm	Code				
				Z5				
				J6				
				55-E063 E3 OU	ON-OFF	100-277V		
2700-3200-4000	80	14.9	760	55-E064 - DL - DU	DALI-2	100-277V		
				55-E065 14 XB	CASAMBI	220-240V		
				60				
				34				

The indicated flux corresponds to the core temperature.
Le flux indiqué correspond à la température centrale.

Rack Bollard Fixed 150×150×700mm

IP	IK		BREEAM	SWITCH CCT		SEA SIDE		
66	06			2700-3200-4000	2 m	SUITABLE		

Z5 14* 60 34* J6* E3* DL*

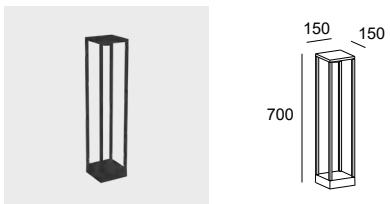

55-E060 55-E061 55-E062

LED								
K	CRI	W Total	Real Lm	Code				
				Z5				
				J6				
				55-E060 E3 OU	ON-OFF	100-277V		
2700-3200-4000	80	14.9	760	55-E061 - DL - DU	DALI-2	100-277V		
				55-E062 14 XB	CASAMBI	220-240V		
				60				
				34				

The indicated flux corresponds to the core temperature.
Le flux indiqué correspond à la température centrale.

* Please contact our sales team for conditions and delivery times.
* Consultez notre équipe commerciale pour connaître les conditions et les délais de livraison.

Rack Bollard Fixed 260×260×900mm

IP
66

IK
06



BREEAM

SWITCH CCT
2700-3200-4000

2 m

SEA SIDE
SUITABLE



OUTDOOR

Z5 14* 60 34* J6* E3* DL*

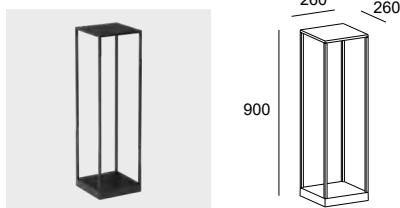

55-E066 55-E067 55-E068

LED (3000K)						
K	CRI	W Total	Real Lm	Code		
					Z5	
					J6	
				55-E066	E3	OU ON-OFF 100-277V
2700-3200-4000	80	14.9	760	55-E067	- DL -	DU DALI-2 100-277V
				55-E068	14	XB CASAMBI 220-240V
				60		
				34		

The indicated flux corresponds to the core temperature.
Le flux indiqué correspond à la température centrale.

Rack Bollard Fixed 150×150×300mm Rack Bollard Fixed 260×260×300mm Rack Bollard Fixed 150×150×700mm Rack Bollard Fixed 260×260×900mm



Lens accessories Accessoires optiques



Spherical opal glass diffuser
Diffuseur sphérique en verre opalin

71-E284-60-F9

71-E284-60-F9

71-E284-60-F9

71-E284-60-F9

Fixing accessories Accessoires de fixation



302mm spiked post
Piquet de 302 mm

71-9998-05-05

71-9998-05-05

71-9998-05-05

71-9998-05-05



235mm spiked post
Piquet de 235 mm

71-9997-05-05

71-9997-05-05

71-9997-05-05

71-9997-05-05

Connection accessories Accessoires de connexion



IP68 connector (1 input + 1 output) Ø 6-17 mm, 5 poles
Connecteur IP68 (1 entrée + 1 sortie) Ø 6 - 17 mm, 5 pôles

71-E361-00-00

71-E361-00-00

71-E361-00-00

71-E361-00-00



IP68 anti-condensation connector (1 input + 1 output) Ø 5.5-12 mm, 4 poles
Connecteur anticondensation IP68 (1 entrée + 1 sortie) Ø 5,5 - 12 mm, 4 pôles

71-E112-00-00

71-E112-00-00

71-E112-00-00

71-E112-00-00



IP68 anti-condensation connector (1 input + 3 outputs) Ø 5.5-12 mm, 4 poles
Connecteur anticondensation IP68 (1 entrée + 3 sorties) Ø 5,5 - 12 mm, 4 pôles

71-E122-00-00

71-E122-00-00

71-E122-00-00

71-E122-00-00



IP68 connection box (1 input + 5 outputs) Ø 6.5-11 mm, 6 poles
Boîtier de raccordement IP67 (1 entrée + 5 sorties) Ø 6,5 - 11 mm, 6 pôles

71-9199-05-05

71-9199-05-05

71-9199-05-05

71-9199-05-05

* Please contact our sales team for conditions and delivery times.
* Consultez notre équipe commerciale pour connaître les conditions et les délais de livraison.

CHILLOUT

Rack Bollard Fixed 150×150×300mm Rack Bollard Fixed 260×260×300mm Rack Bollard Fixed 150×150×700mm Rack Bollard Fixed 260×260×900mm



Decorative accessories
Accessoires décoratifs



Decorative grids set (4u.)
Set de grilles décoratives (4 u.)

60 ●	71-E279-60-00	71-E281-60-00	71-E280-60-00	71-E282-60-00
Z5 ● *	71-E279-Z5-00	71-E281-Z5-00	71-E280-Z5-00	71-E282-Z5-00
J6 ● *	71-E279-J6-00	71-E281-J6-00	71-E280-J6-00	71-E282-J6-00
E3 ● *	71-E279-E3-00	71-E281-E3-00	71-E280-E3-00	71-E282-E3-00
DL ● *	71-E279-DL-00	71-E281-DL-00	71-E280-DL-00	71-E282-DL-00
14 ○ *	71-E279-14-00	71-E281-14-00	71-E280-14-00	71-E282-14-00
34 ○ *	71-E279-34-00	71-E281-34-00	71-E280-34-00	71-E282-34-00

Rack

Wall Fixture

BODY MAT	DIF MAT	50000h	3
AL,CON	GLA	L80 B20	MacAdam

Rack Wall Fixture

150×150×160mm

IP 66 IK 06 BREEAM SWITCH CCT 2700-3200-4000 2 m SEA SIDE SUITABLE LED DRIVER

Z5 14* 60 34* J6* E3* DL*

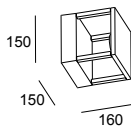
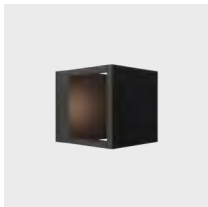

05-E071 05-E076 05-E077

LED						
K	CRI	W Total	Real Lm	Code		
				Z5		
				J6		
2700-3200-4000	80	14.9	760	05-E071 E3 OU	ON-OFF 100-277V	
				05-E076 - DL - DU	DALI-2 100-277V	
				05-E077 14 XB	CASAMBI 220-240V ⚡	
				60		
				34		

The indicated flux corresponds to the core temperature.
Le flux indiqué correspond à la température centrale.

Rack Wall Fixture

150×150×300mm

IP 66 IK 06 BREEAM SWITCH CCT SW 2700-3200-4000 2 m SEA SIDE SUITABLE LED DRIVER

Z5 14* 60 34* J6* E3* DL*

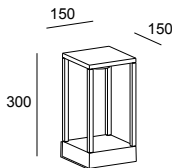

05-E082 05-E088 05-E089

LED						
K	CRI	W Total	Real Lm	Code		
				Z5		
				J6		
2700-3200-4000	80	14.9	760	05-E082 E3 OU	ON-OFF 100-277V	
				05-E088 - DL - DU	DALI-2 100-277V	
				05-E089 14 XB	CASAMBI 220-240V ⚡	
				60		
				34		

The indicated flux corresponds to the core temperature.
Le flux indiqué correspond à la température centrale.

* Please contact our sales team for conditions and delivery times.
* Consultez notre équipe commerciale pour connaître les conditions et les délais de livraison.

Rack Wall Fixture
150×150×160mm

Rack Wall Fixture
150×150×300mm



Lens accessories
Accessoires optiques



Spherical opal glass diffuser
Diffuseur sphérique en verre opalin

-

71-E284-60-F9

Connection accessories
Accessoires de connexion



IP68 connector (1 input + 1 output) Ø 6-17 mm, 5 poles
Connecteur IP68 (1 entrée + 1 sortie) Ø 6 - 17 mm, 5 pôles

71-E361-00-00

71-E361-00-00



IP68 anti-condensation connector (1 input + 1 output) Ø 5,5-12 mm, 4 poles
Connecteur anticondensation IP68 (1 entrée + 1 sortie) Ø 5,5 - 12 mm, 4 pôles

71-E112-00-00

71-E112-00-00



IP68 anti-condensation connector (1 input + 3 outputs) Ø 5.5-12 mm, 4 poles
Connecteur anticondensation IP68 (1 entrée + 3 sorties) Ø 5,5 - 12 mm, 4 pôles

71-E122-00-00

71-E122-00-00



IP68 connection box (1 input + 5 outputs) Ø 6.5-11 mm, 6 poles
Boîtier de raccordement IP67 (1 entrée + 5 sorties) Ø 6,5 - 11 mm, 6 pôles

71-9199-05-05

71-9199-05-05

Decorative accessories
Accessoires décoratifs



Decorative grids set (4u.)
Set de grilles décoratives (4 u.)

60 ●

71-E278-60-00

71-E279-60-00

Z5 ● *

71-E278-Z5-00

71-E279-Z5-00

J6 ● *

71-E278-J6-00

71-E279-J6-00

E3 ● *

71-E278-E3-00

71-E279-E3-00

DL ● *

71-E278-DL-00

71-E279-DL-00

14 ○ *

71-E278-14-00

71-E279-14-00

34 ● *

71-E278-34-00

71-E279-34-00

Moal

Designed by Francesc Vilaró



+ Moal

Wall Fixture
P. 862

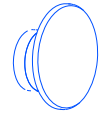

Decorative lighting that works as furniture Éclairage décoratif qui sert également de mobilier

The Moal collection is not only a bollard light, but can also be used as furniture in all kinds of outdoor settings, both in those filled with vegetation and in more architectural scenes, where its cement finish allows it to blend in seamlessly with its surroundings.

La collection Moal n'est pas qu'une borne d'éclairage, elle peut également servir de mobilier d'extérieur dans toutes sortes de contextes, aussi bien dans ceux où la végétation abonde que dans des cadres plus architecturaux où sa finition en ciment permet une intégration totale dans l'environnement.



Moal finishes are unique thanks to the use of cement, a noble and artisan material whose irregular surface can vary from piece to piece, making them all one-of-a-kind.

Les finitions de Moal sont uniques grâce au ciment, matériau noble et artisanal dont la surface irrégulière peut varier d'une pièce à l'autre, ce qui leur confère un caractère distinctif.



In addition to being a decorative outdoor luminaire, Moal can be used as a piece of furniture. Outre sa fonction de luminaire décoratif d'extérieur, Moal peut servir de mobilier.



Made of 100% cement. Metal reinforcement to ensure robustness and durability.

100 % ciment. Dotée d'une armature métallique à l'intérieur pour garantir robustesse et durabilité.

Moal Wall Fixture

BODY MAT	DIF MAT		50000h	3	IP	IK	LOW		SEA SIDE SUITABLE		
AL.CON	PC		L80 B20	MacAdam	66	10	FLICKER				

DC

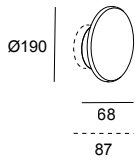
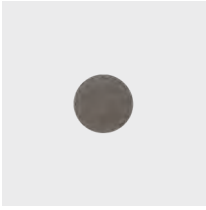

LED							
K	CRI	W Total	Real Lm	Code			
3000	90	11.1	312	05-E087 - DC - CL	ON-OFF 100-240V		

Fixing accessories

Accessoires de fixation



Elevating accessory
Élévateur

Included

Moal 455mm

BODY MAT	DIF MAT		50000h	3	IP	IK		SEA SIDE SUITABLE			
AL.CON	PC		L80 B20	MacAdam	66	10					

DC

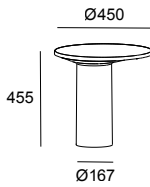

LED							
K	CRI	W Total	Real Lm	Code			
3000	90	16.3	729	55-E087 - DC - CL	ON-OFF 100-240V		

Moal 705mm

BODY MAT	DIF MAT		50000h	3	IP	IK		SEA SIDE SUITABLE			
AL.CON	PC		L80 B20	MacAdam	66	10					

DC

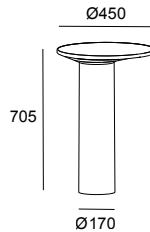

LED							
K	CRI	W Total	Real Lm	Code			
3000	90	16.3	729	55-E088 - DC - CL	ON-OFF 100-240V		

Fixing accessories

Accessoires de fixation



Fixing bolts
Boulons de fixation

71-E157-00-00

Barcino

Designed by Manel Llusçà



Soft light for large spaces Lumière douce pour grands espaces

Barcino's rotationally moulded diffuser allows you to illuminate large spaces with soft light. The different finishes in the collection and its three different heights make it possible to devise unique compositions with tons of personality.

Le diffuseur rotomoulé Barcino permet d'éclairer de vastes espaces tout en douceur. Les différentes finitions de la collection et ses trois hauteurs différentes permettent de créer des compositions uniques à forte personnalité.



14



34



DL



E3



J6



Z5



60





BODY MAT	DIF MAT		IP	IK		SEA SIDE SUITABLE
AL	PLABS		65	10		

Z5 14* 60* 34* J6* E3* DL*

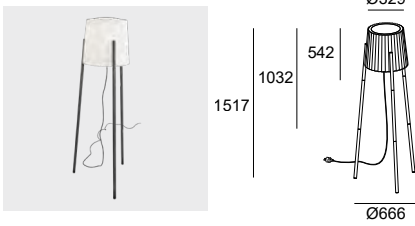

E27	
W	Code
	Z5
	J6
	E3
Max. 15	55-9880 - DL - M1
	14
	60
	34

* Please contact our sales team for conditions and delivery times.
 * Consultez notre équipe commerciale pour connaître les conditions et les délais de livraison.





+ Cisne



Classic, elegant and decorative

Classique, élégante et décorative

Cisne is a classic decorative sphere that brings comfort, warmth and elegance to gardens and terraces with attention to detail.

Cisne est une sphère décorative classique qui apporte confort, chaleur et élégance aux jardins et terrasses soignés dans les moindres détails.

Cisne Pendant

Ø300 mm



Ø400 mm



Cisne Surface

Ø300 mm



Ø400 mm



Ø500 mm





**Cisne Pendant
Ø300mm**

BODY MAT
PC

DIF MAT
PMMA



IP
44

IK
06

BREEAM

SEA SIDE
SUITABLE

○
14

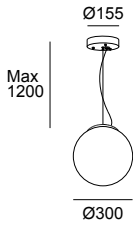

E27	
W	Code
Max. 15	00-9155 - 14 - M1

**Cisne Pendant
Ø400mm**

BODY MAT
PC

DIF MAT
PMMA



IP
44

IK
06

BREEAM

SEA SIDE
SUITABLE

○
14

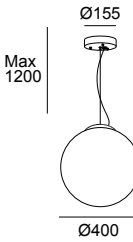

E27	
W	Code
Max. 15	00-9156 - 14 - M1

Cisne Surface
Ø300mm

BODY MAT	DIF MAT		IP	IK	BREEAM	SEA SIDE SUITABLE
PC	PMMA		44	06		

○
M1

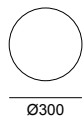
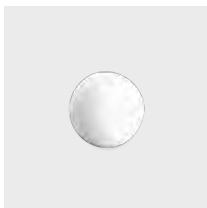

E27	
W	Code
Max. 15	55-9155 - M1 - M1

Cisne Surface
Ø400mm

BODY MAT	DIF MAT		IP	IK	BREEAM	SEA SIDE SUITABLE
PC	PMMA		44	06		

○
M1

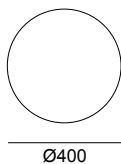
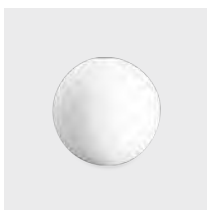

E27	
W	Code
Max. 15	55-9156 - M1 - M1

Cisne Surface
Ø500mm

BODY MAT	DIF MAT		IP	IK	BREEAM	SEA SIDE SUITABLE
PC	PMMA		44	06		

○
M1

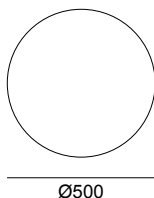

E27	
W	Code
Max. 15	55-9481 - M1 - M1

Fixing accessories
Accessoires de fixation



Spiked post
Piquet

Included

Easy Safe Garden

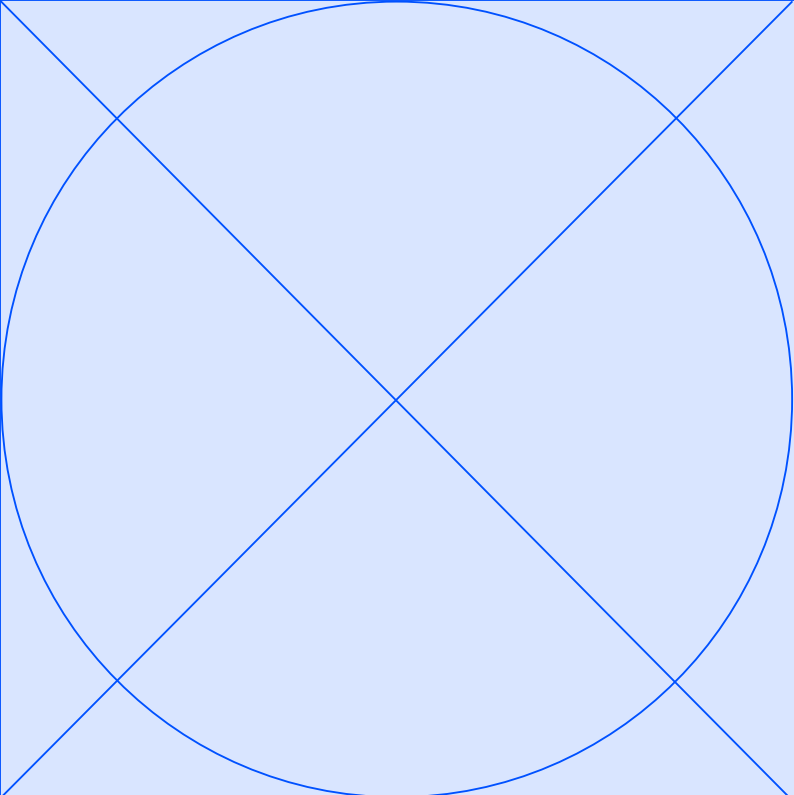

Zoom
920



Gea Technopolymer
920

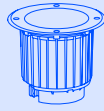

Cisne
921

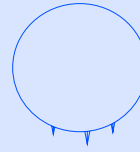

Orbit
921



Easy Safe Garden



Simple and secure installation, perfect for gardens

Installation facile et sûre idéale pour les jardins

This system is designed to illuminate large garden areas through a straightforward, speedy and safe installation process. It includes a power supply and a wiring system that allows for easy luminaire interlinking.

Ce système est conçu pour éclairer de vastes espaces paysagés grâce à une installation facile, rapide et sûre. Il est doté d'une source d'alimentation et d'un système de câblage qui permet d'enchaîner les luminaires en toute facilité.

Zoom



Gea Technopolymer



Cisne



Orbit







Dimmable lighting Éclairage réglable

Two system options are available: ON/OFF and DALI2. Opting for the second choice enables you to adjust the light as needed, creating even more intimate and inviting settings.

Il y a deux options d'appareillage disponibles : ON/OFF et DALI2. Le choix de cette deuxième option permet d'atténuer la lumière si nécessaire, créant ainsi des décors encore plus intimes et accueillants.

Connect the installation in just minutes Permet de brancher l'installation en quelques minutes

Reliable and easy installation with watertight, threaded-locking quick connectors.
Installation fiable et facile grâce aux connecteurs étanches rapides à visser.



Enhanced safety thanks to low voltage
Sécurité maximale grâce à la basse tension

Zoom
Ø34 mm

BODY MAT AL	DIF MAT GLA		50000h L80 B20	IP 66	IK 10	2 MacAdam	BREEAM				SEA SIDE SUITABLE	

05

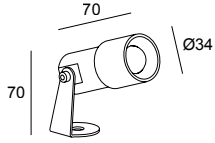

K	CRI	W Total	Real Lm	Optics	Code	
2700	80	5.3	348	17° - 40°	05-E161-05 - CK CL	
3000	80	5.3	374	17° - 40°		

Fixing accessories
Accessoires de fixation



Base for surface mounting
Socle à fixer en surface

Included



Spiked post
Piquet

Included

Gea Technopolymer
Ø125 mm

BODY MAT AL	DIF MAT GLA		50000h L80 B20	IP 66-67	IK 10	3 MacAdam		

		SEA SIDE SUITABLE	
--	--	----------------------	--

CA

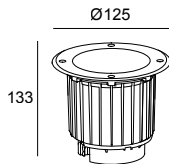

K	CRI	W Total	Real Lm	Optics	Code	
2700	80	6.4	956	17°	55-E112-CA - CK CL	
3000	80	6.4	956	17°		

Lens accessories
Accessoires optiques



Honeycomb panel
Panneau en nid d'abeille

Included



Asymmetric filter
Filtre asymétrique

Included



Set of 2 reflectors (17° and 53°)
Set de 2 réflecteurs (17° et 53°)

Included

Set of 2 reflectors (21° and 54°)
Set de 2 réflecteurs (21° et 54°)

-

Fixing accessories
Accessoires de fixation



Recess case
Boîtier d'encastrement

Included

Cisne
Ø280 mm

BODY MAT	DIF MAT		50000h	3	IP	IK			
PC	PE		L80 B20	MacAdam	66	10			

Z5

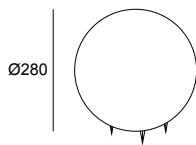
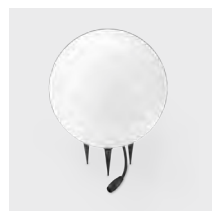

K	CRI	W Total	Real Lm	Code	
2700-3200-4000	80	4.2	400	55-E113-M1-EH	48VDC

Orbit
700 mm

BODY MAT	DIF MAT		50000h	IP	IK	3			
AL	PC		L80 B20	66	10	MacAdam			

60

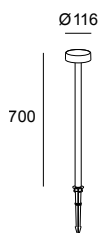

K	CRI	W Total	Real Lm	Code	
2700-3200-4000	80	3.2	308	10-E029-60-EH	48VDC

Fixing accessories
Fixing accessories



Spiked post
Piquet

Included

Connection accessories
Accessoires de connexion



48V Cable with waterproof tongue and groove connectors (1 m)
Câble 48V avec connecteurs étanches mâle-femelle (1 m)

71-E437-05-05

48V Cable with waterproof tongue and groove connectors (5 m)
Câble 48V avec connecteurs étanches mâle-femelle (5 m)

71-E427-05-05

Extension 10000 mm
Rallonge 10 000 mm

71-E552-05-05



320 W ON/OFF box
Boîtier 320 W ON-OFF

71-E610-00-00



200 W DALI box
Boîtier 200 W DALI

71-E611-00-00



"T" connector
Connecteur "T"

71-E557-05-05

Emergency Lighting

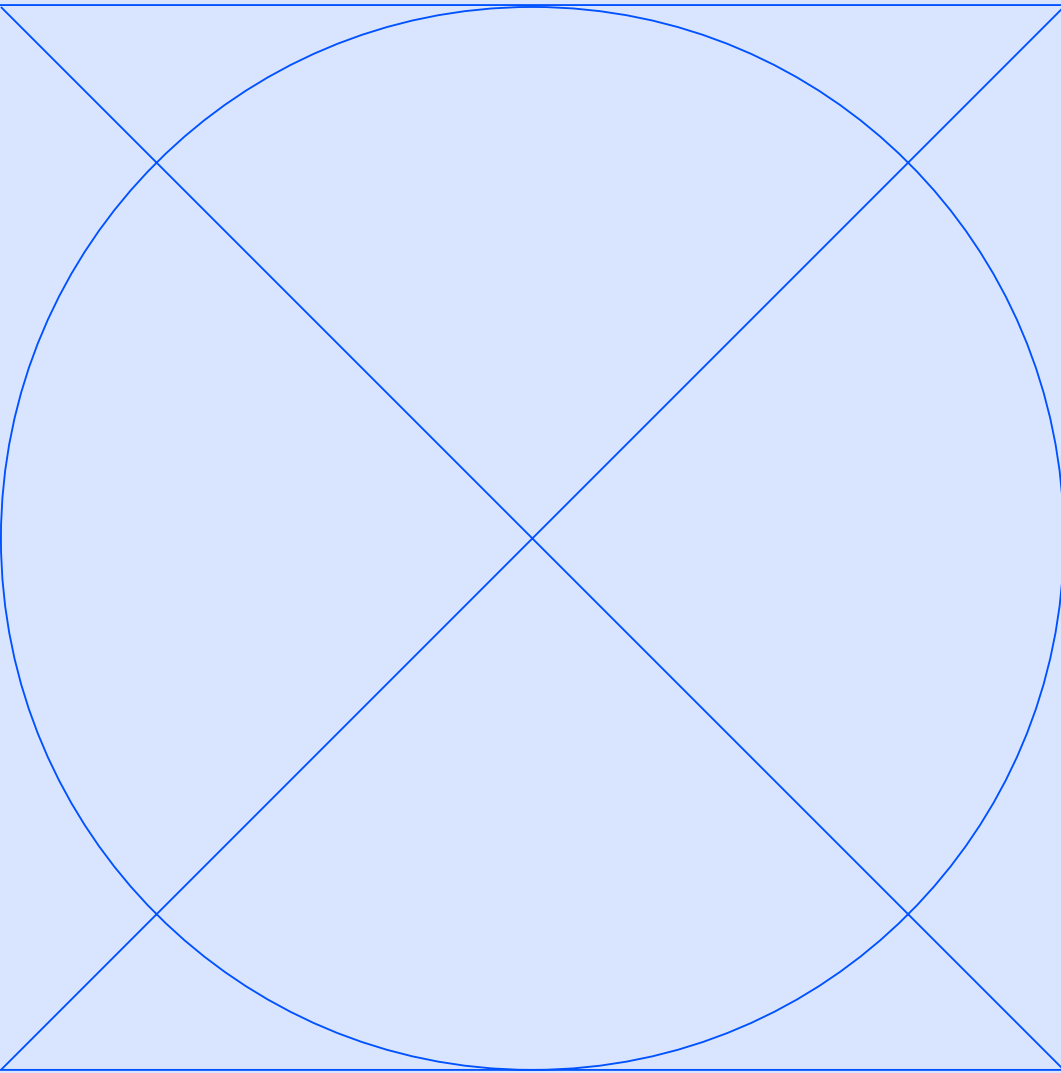

Redo

930

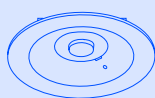

Deco

933

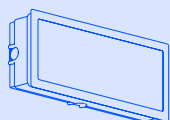

Flag

938

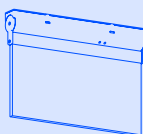

Star

938



Deco Track

939

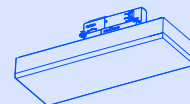

Line

940

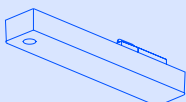

Leco

941

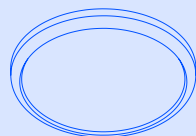

Play

942

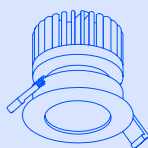

Infinite Pro

953

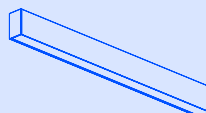

Bento

959

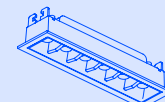

Afrodita

961

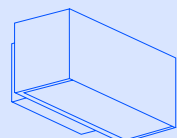

Vol

962



Veo

964

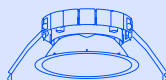

Ecofit

966

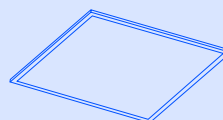

Emergency lighting

Éclairage de secours

Emergency lighting, like technical or decorative lighting, plays a very important role in the safety and well-being of people. It's an essential, mandatory element that allows us to guide ourselves to a safe evacuation route in the event of an emergency. These types of luminaires, which start to operate when all others cease to do so, are strategically positioned in buildings such as shopping centres, hotels, hospitals and offices. For this reason, selecting quality emergency lighting is an act of responsibility towards the people who use it. Here at LedsC4, we're committed to this lighting's technical and performance qualities, and we also work to ensure it causes the least intrusion possible and it perfectly integrates within any space.

Au même titre que l'éclairage technique ou décoratif, l'éclairage de secours joue un rôle très important en termes de sécurité et de bien-être des personnes. C'est un élément indispensable et obligatoire, qui nous permet d'être guidés vers une évacuation sûre en cas d'urgence. Ces types de luminaires, qui prennent le relais lorsque les autres cessent de fonctionner, sont placés stratégiquement dans des bâtiments tels que des centres commerciaux, des hôtels, des hôpitaux ou des bureaux. Par conséquent, le choix d'un éclairage de sécurité de qualité est un acte de responsabilité envers les personnes qui l'utilisent. Chez LEDS C4, nous nous engageons non seulement vis-à-vis des qualités techniques et fonctionnelles de ces luminaires, mais nous œuvrons aussi pour qu'ils détonnent le moins possible et s'intègrent parfaitement dans n'importe quel espace

Emergency lighting plays a very important role in people's safety and well-being.

L'éclairage de secours joue un rôle très important dans la sécurité et le bien-être des personnes.



Types of emergency lighting

Type de luminaires de secours

LedsC4 offers two types of emergency lighting: emergency luminaires and technical emergency luminaires. The former are standard solutions, while the latter combine technical features with those inherent to emergency lighting. In doing so, we can offer a more versatile product that can be integrated within any project, while complying with regulations and respecting the aesthetics of the space.

Leds C4 propose deux types de luminaires de secours : les modèles standard et les modèles techniques. Alors que les premiers sont des solutions standard, les seconds associent des caractéristiques techniques à celles de l'éclairage de secours. Cela permet de proposer un produit plus polyvalent qui peut être intégré dans n'importe quel projet, en respectant les réglementations et sans empiéter esthétiquement sur l'espace.

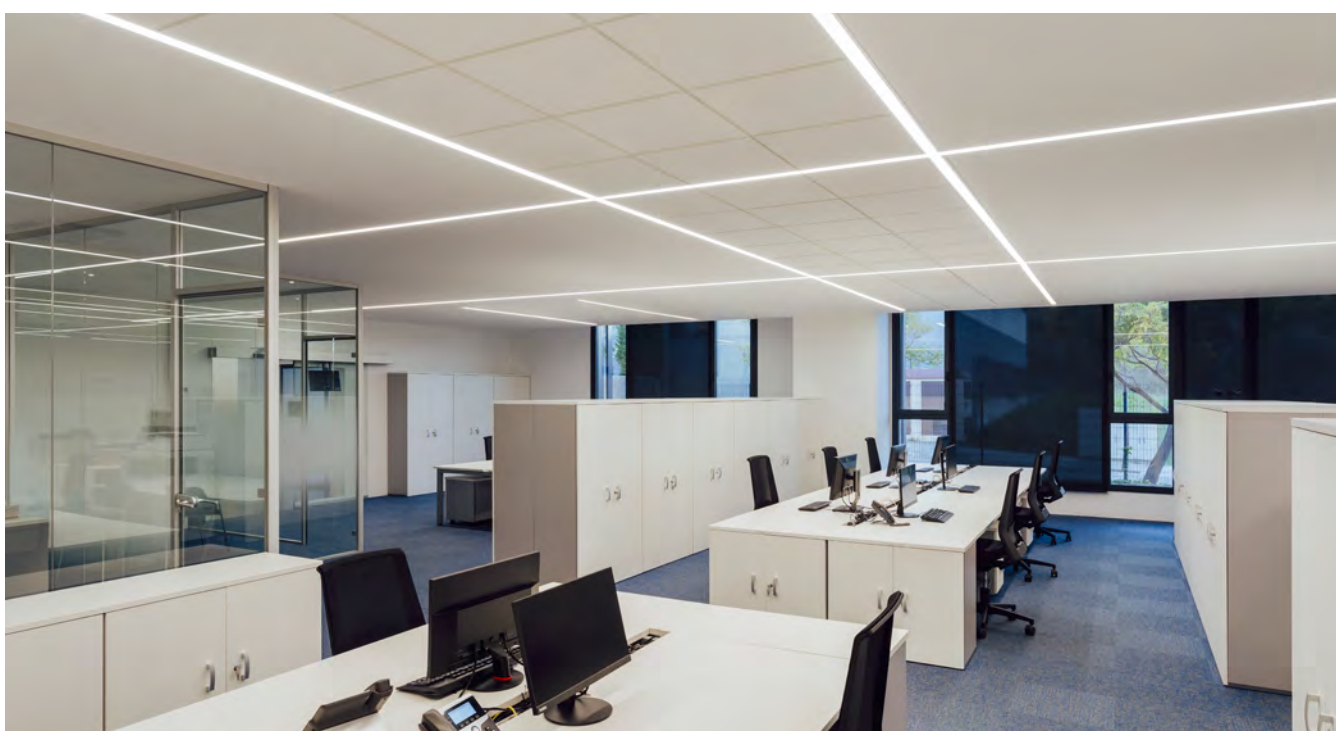
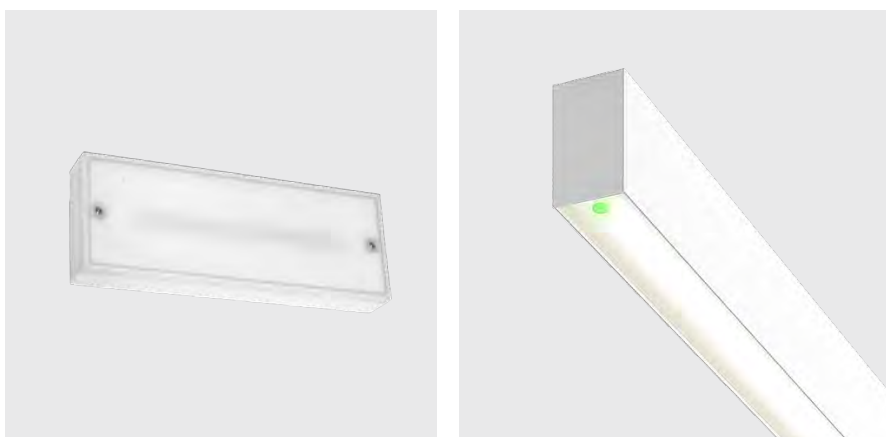

Manusa, Polinyà (Barcelona)
Photography: Enric Badrinas.

Maintained mode and non-maintained mode

Mode permanent et non permanent

In maintained mode, the light source is constantly active, both when it's supplied with electricity and when it's not. Conversely, in non-maintained mode the light source remains on standby, switched off, until there is a failure in the electricity supply, in which case it is switched on.

En mode permanent, la source lumineuse est constamment active avec ou sans alimentation électrique. En revanche, en mode non permanent, la source lumineuse reste éteinte mais en état d'alerte jusqu'à ce qu'une panne de courant se produise, auquel cas elle s'allume.

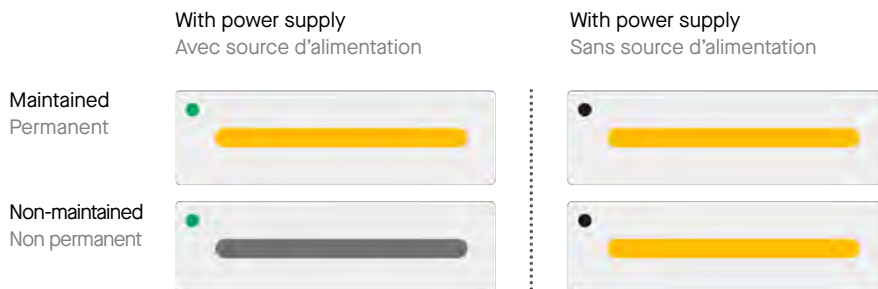

Self-test feature

Mode autotest

Self-test luminaires periodically and autonomously check their status and battery to ensure they are fully operational, signalling their status through their LED light. They perform a function test every 30 days and a duration test every 52 weeks. Les luminaires dotés du mode autotest sont en mesure d'effectuer régulièrement un contrôle autonome de leur état et de leur batterie, afin de garantir leur état et de l'afficher par le biais de leur LED de signalisation. Ils effectuent un test de fonction tous les 30 jours et un test de durée toutes les 52 semaines.

The function test simulates a mains outage for 2 minutes and checks that the emergency luminaire is working correctly.

Conversely, the **duration test** simulates a mains outage lasting 1 to 3 hours to check the battery life.

Le test de fonctionnement simule une panne de secteur pendant 2 minutes et vérifie le bon fonctionnement du luminaire de secours.

Le test de durée simule une panne de secteur pendant 1 ou 3 heures pour vérifier l'autonomie de la batterie

LED	Status Statut	Failure indication Indication de panne
● Solid green Vert fixe	Switched off Éteint	
● Flashing green ○ Vert clignotant	Slow flashing Intermittent lent	2-min operational test Test de fonctionnement de 2 min
	Fast flashing Intermittent rapide	1-hour duration test Test de durée de 1 heure
● Flashing green ○ Rouge clignotant	1 blinking / clignotements	Battery failure Panne de batterie
	2 blinking / clignotements	Light bulb failure Panne d'ampoule
	3 blinking / clignotements	Duration test failure Erreur du test de durée
● Solid green Vert fixe	Mains switched on Réseau allumé	No failures Sans panne
○ Green switched off Vert éteint	Failure Panne	Check battery Vérifier la batterie

Luminaire status monitoring

Surveillance de l'état des luminaires

This feature allows you to check and obtain information about the luminaire's operation so that you can anticipate and predict when maintenance is required. Thanks to this system, the user can access information on the battery's condition and charge level, installation data and emergency status.

Permet de vérifier et d'obtenir des informations sur leur fonctionnement, ce qui permet d'anticiper et de programmer les besoins d'entretien des luminaires. Ces systèmes fournissent des informations sur l'état de la batterie et sa charge, les données de l'installation et la situation d'urgence

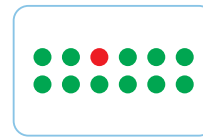
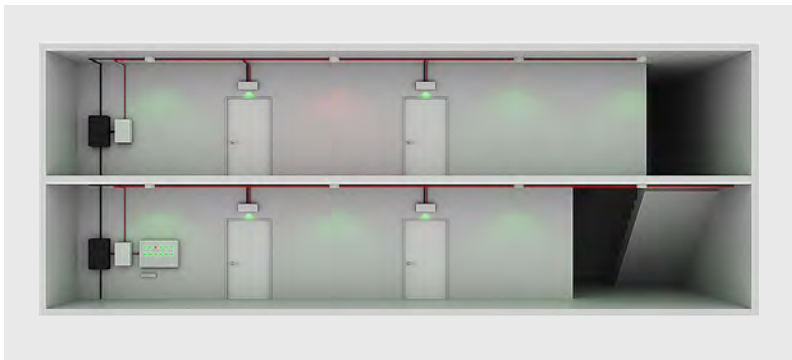

Dali systems

Systèmes DALI

The DALI control system, connected and wired to the DALI emergency luminaires, allows you to do remote checks without the need to perform visual checks on the signalling LEDs. Connecté et câblé aux luminaires de secours DALI, le système de contrôle DALI facilite la surveillance à distance et évite d'avoir à mener un contrôle visuel des LED de signalisation.

Wireless

Casambi

The DALI control system, connected and wired to the DALI emergency luminaires, allows you to do remote checks without the need to perform visual checks on the signalling LEDs. Connecté et câblé aux luminaires de secours DALI, le système de contrôle DALI facilite la surveillance à distance et évite d'avoir à mener un contrôle visuel des LED de signalisation.

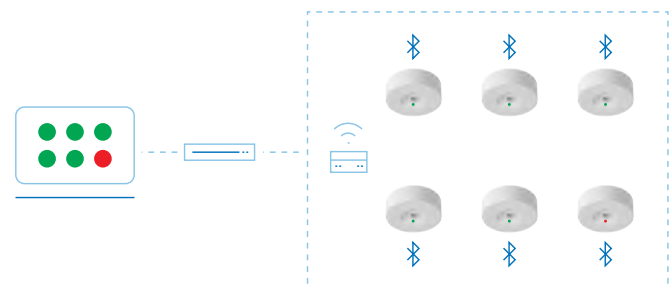



Redo



A collection of emergency downlights with a simple design and pure lines available in recessed and surface-mounted versions. Allows for full integration in the space with its recessed version, which goes unnoticed thanks to the fact that its point of light is set back, thus improving visual comfort. Designed for settings such as hotels, corridors, residences and offices.

Collection de downlights de secours au design simple et aux lignes épurées, en version encastrée et de surface. Permet une intégration totale dans l'espace avec sa version encastrée, qui se fond dans le décor grâce à son point lumineux en retrait, ce qui améliore le confort visuel. Conçue pour des espaces tels que des hôtels, couloirs, résidences et bureaux.



Standard lens: offers high uniformity, ideal for square spaces and open areas.

Lentille standard : offre un grande uniformité, idéale pour les espaces carrés et les espaces ouverts

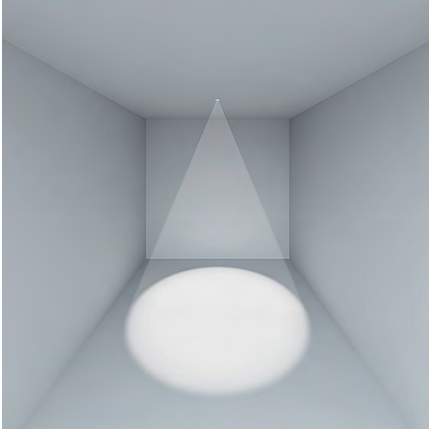

Corridor lens: ideal for long spaces such as corridors. Large intervals between luminaires.

Lentille corridor : idéale pour les espaces en longueur, tels que les couloirs. Grandes distances entre luminaires.

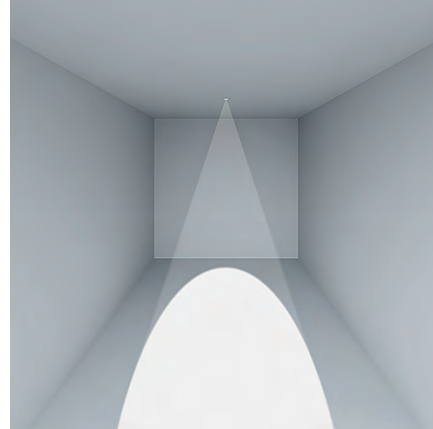

DALI monitoring Surveillance DALI

Real-time luminaire controller.
Contrôleur du luminaire en temps réel.

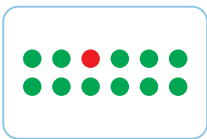
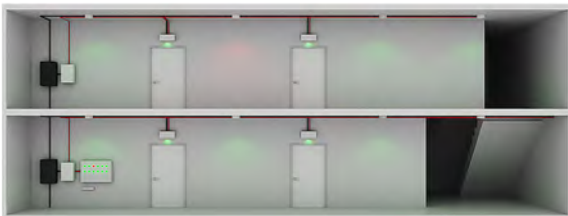

Facility versatility Installation polyvalente



Redo Recessed

BODY MAT	DIF MAT		50000h	3	IP	IK	UGR			
PC	PC		L80 B20	MacAdam	20	10	<10			

○ ●
14 60



28

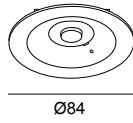

70 0-15 mm

LED | K : 4000 | CRI : 80 | BATTERY: NiCd

W	Real Lm Emer.	Optics	H. Emer.	Permanent	Auto test	Code	220-240V
2.7	276	29°	1	Yes / No	No	EM04-0200PN1400	ON-OFF
2.7	276	29°	1	Yes / No	Yes	EM04-0200PA1400	ON-OFF
2.7	276	29°	1	Yes / No	No	EM04-0200PN6000	ON-OFF
2.7	276	29°	3	Yes / No	No	EM04-0203PN6000	ON-OFF
2.7	276	29°	1	Yes / No	Yes	EM04-0200PA6000	ON-OFF
2.7	276	29°	3	Yes / No	Yes	EM04-0203PA6000	ON-OFF
2.7	276	29°	1	Yes / No	Yes	EM04-0200PA1401	DALI
2.7	276	29°	1	Yes / No	Yes	EM04-0200PA6001	DALI
4	276	29°	3	Yes / No	No	EM04-0203PN1400	ON-OFF
4	276	29°	3	Yes / No	Yes	EM04-0203PA1400	ON-OFF
4	276	29°	3	Yes / No	Yes	EM04-0203PA1401	DALI
4	276	29°	3	Yes / No	Yes	EM04-0203PA6001	DALI

Redo Surface

BODY MAT	DIF MAT		50000h	3	IP	IK	UGR			
PC	PC		L80 B20	MacAdam	20	10	<10			

○ ●
14 60



40.5

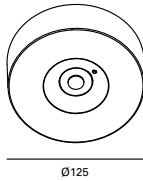

LED | K : 4000 | CRI : 80 | BATTERY: Lithium ion

W	Real Lm Emer.	Optics	H. Emer.	Permanent	Auto test	Code	220-240V
4	276	29°	3	Yes / No	No	EM05-0203PN6000	ON-OFF
4	276	29°	3	Yes / No	Yes	EM05-0203PA6000	ON-OFF
4	276	29°	3	Yes / No	Yes	EM05-0203PA1400	ON-OFF
4	276	29°	3	Yes / No	No	EM05-0203PN1400	ON-OFF
4	276	29°	3	Yes / No	Yes	EM05-0203PA1401	DALI
4	276	29°	3	Yes / No	Yes	EM05-0203PA6001	DALI

Fixing accessories

Accessoires de fixation



White Diameter adapter Redo
Adaptateur de diamètre Blanc Redo

EM04-0001



Black Diameter adapter Redo
Adaptateur de diamètre Noir Redo

EM04-0003

Decorative accessories

Accessoires décoratifs



Redo Recessed Pictogram Accessorie
Accessoire Redo Pictogramme encastré

EM04-0002



This is a conventional emergency luminaire that is installed on the wall or ceiling, either on the surface or recessed (via accessory). Its shape and finish mean it goes unnoticed in the space. Luminaire de secours conventionnel pour installation au mur ou au plafond, en surface ou encastrée (via un accessoire). Grâce à sa forme et à sa finition, ce modèle passe inaperçu dans le décor.

DALI monitoring Suivi DALI

Thanks to the DALI versions, its operational status can be monitored in real time.

Les versions DALI permettent de suivre l'état de fonctionnement du luminaire en temps réel.

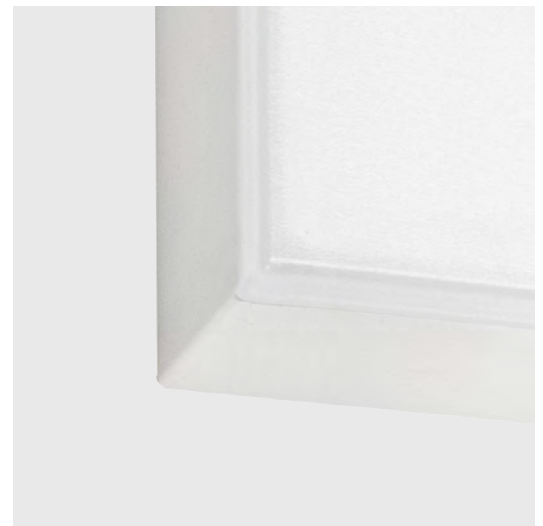

It has straight, clean, pure forms with a matte finish to help it go unnoticed in the space.

Doté de formes droites, nettes et épurées, avec une finition texturée mate pour passer inaperçu.

Diverse accessories Diversité des accessoires



Wall recess accessory
Accessoire d'encastrement mural

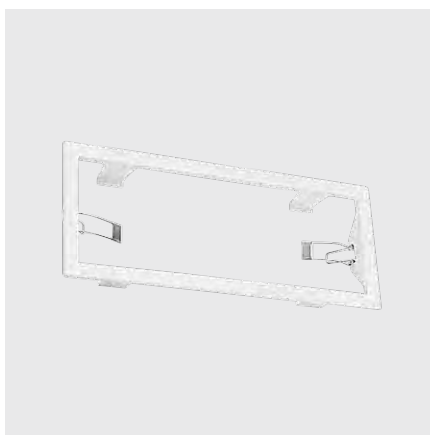

Ceiling recess accessory
Accessoire d'encastrement au plafond

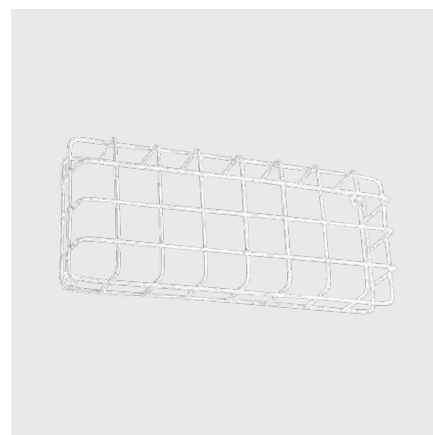

Anti-vandalism accessory
Accessoire antivandalisme



Sign accessory
Accessoire de signalisation

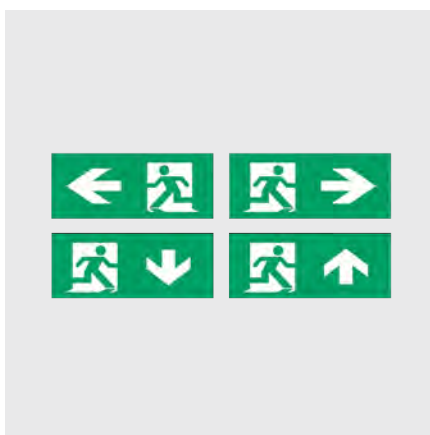

Pictogram accessory
Accessoire pictogrammes

BODY MAT	DIF MAT		50000h	5
PC	PC		L80 B20	MacAdam

Deco IP44 NiCd

IP	IK		
44	10		

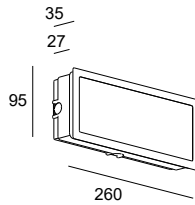

14

LED | K : 4000 | CRI : 80 | BATTERY: NiCd

W	Real Lm Emer.	H. Emer.	Permanent	Auto test	Code	 220-240V
2	60	1	No	No	EM01-0060NN1400	ON-OFF
2	120	1	No	No	EM01-0100NN1400	ON-OFF
2	160	1	No	No	EM01-0150NN1400	ON-OFF
2	160	1	No	No	EM01-0200NN1400	ON-OFF
3	200	1	No	No	EM01-0300NN1400	ON-OFF
3	450	1	No	No	EM01-0500NN1400	ON-OFF
2	120	1	No	Yes	EM01-0100NA1400	ON-OFF
2	160	1	No	Yes	EM01-0200NA1400	ON-OFF
3	200	1	No	Yes	EM01-0300NA1400	ON-OFF
2	120	3	No	No	EM01-0103NN1400	ON-OFF
2	160	3	No	No	EM01-0203NN1400	ON-OFF
3	200	1	No	Yes	EM01-0300NA1401	DALI
3.4	120	1	Yes	No	EM01-0100PN1400	ON-OFF
3.4	120	3	Yes	No	EM01-0103PN1400	ON-OFF
3.7	120	1	Yes	Yes	EM01-0100PA1400	ON-OFF
4.3	160	1	Yes	Yes	EM01-0200PA1400	ON-OFF
4.3	160	1	Yes	No	EM01-0200PN1400	ON-OFF
4.3	160	3	Yes	No	EM01-0203PN1400	ON-OFF
5.5	200	1	Yes	No	EM01-0300PN1400	ON-OFF
5.5	200	1	Yes	Yes	EM01-0300PA1400	ON-OFF
5.5	200	1	Yes	Yes	EM01-0300PA1401	DALI
6	450	1	Yes	No	EM01-0500PN1400	ON-OFF

Deco IP44 NiMH

IP	IK		
44	10		

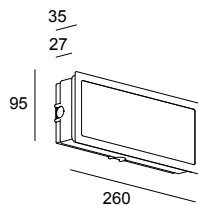

14

LED | K : 4000 | CRI : 80 | BATTERY: NiMH

W	Real Lm Emer.	H. Emer.	Permanent	Auto test	Code	 220-240V
3	280	3	No	No	EM01-0303NN1400	ON-OFF
3	280	3	No	Yes	EM01-0303NA1400	ON-OFF
3	280	3	No	Yes	EM01-0303NA1401	DALI
5.5	280	3	Yes	No	EM01-0303PN1400	ON-OFF
5.7	280	3	Yes	Yes	EM01-0303PA1400	ON-OFF
5.7	280	3	Yes	Yes	EM01-0303PA1401	DALI

Deco IP65

BODY MAT PC	DIF MAT PC		50000h L80 B20	5 MacAdam
----------------	---------------	------------------------------------------------------------------------------------	-------------------	--------------

Deco IP65 Battery NiCd

IP 65	IK 10		
----------	----------	-------------------------------------------------------------------------------------	-------------------------------------------------------------------------------------

14

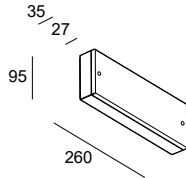



LED K : 4000 CRI : 80 BATTERY: NiCd						
W	Real Lm Emer.	H. Emer.	Permanent	Auto test	Code	 220-240V
2	60	1	No	No	EM02-0060NN1400	ON-OFF
2	120	1	No	No	EM02-0100NN1400	ON-OFF
2	160	1	No	No	EM02-0150NN1400	ON-OFF
2	160	1	No	No	EM02-0200NN1400	ON-OFF
3	200	1	No	No	EM02-0300NN1400	ON-OFF
3	450	1	No	No	EM02-0500NN1400	ON-OFF
2	120	1	No	Yes	EM02-0100NA1400	ON-OFF
2	160	1	No	Yes	EM02-0200NA1400	ON-OFF
3	200	1	No	Yes	EM02-0300NA1400	ON-OFF
2	120	3	No	No	EM02-0103NN1400	ON-OFF
2	160	3	No	No	EM02-0203NN1400	ON-OFF
3	200	1	No	Yes	EM02-0300NA1401	DALI
3.4	120	1	Yes	No	EM02-0100PN1400	ON-OFF
3.4	120	3	Yes	No	EM02-0103PN1400	ON-OFF
3.7	120	1	Yes	Yes	EM02-0100PA1400	ON-OFF
4.3	160	1	Yes	Yes	EM02-0200PA1400	ON-OFF
4.3	160	1	Yes	No	EM02-0200PN1400	ON-OFF
4.3	160	3	Yes	No	EM02-0203PN1400	ON-OFF
5.5	200	1	Yes	No	EM02-0300PN1400	ON-OFF
5.5	200	1	Yes	Yes	EM02-0300PA1400	ON-OFF
5.5	200	1	Yes	Yes	EM02-0300PA1401	DALI
6	450	1	Yes	No	EM02-0500PN1400	ON-OFF



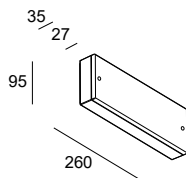

Deco IP65 Battery NiMH

IP 65	IK 10		
----------	----------	---------------------------------------------------------------------------------------	---------------------------------------------------------------------------------------



14









LED K : 4000 CRI : 80 BATTERY: NiMH						
W	Real Lm Emer.	H. Emer.	Permanent	Auto test	Code	 220-240V
3	280	3	No	No	EM02-0303NN1400	ON-OFF
3	280	3	No	Yes	EM02-0303NA1400	ON-OFF
3	280	3	No	Yes	EM02-0303NA1401	DALI
5.5	280	3	Yes	No	EM02-0303PN1400	ON-OFF
5.7	280	3	Yes	Yes	EM02-0303PA1400	ON-OFF
5.7	280	3	Yes	Yes	EM02-0303PA1401	DALI

	Deco IP44 NiCD	Deco IP44 NiMH	Deco IP65 Battery NiCD	Deco IP65 Battery NiMH
				

Fixing accessories
Accessoires de fixation

	Deco flush mount wall accessory Accessoire d'encastrement mural Deco	EM01-0002	EM01-0002	EM01-0002	EM01-0002
	DECO flush mount accessory Accessoire d'encastrement DECO	EM01-0001	EM01-0001	-	-

Decorative accessories
Accessoires décoratifs

	Accessorie Deco Anti Vandalism Accessoire Deco anti vandalisme	EM01-0003	EM01-0003	EM01-0003	EM01-0003
	Accessorie Signalling Deco Accessoire Signalisation Deco	-	-	EM02-0004	EM02-0004
	Down arrow pictogram Pictogramme flèche vers le bas	EM01-0008	EM01-0008	EM01-0008	EM01-0008
	Up arrow pictogram Pictogramme flèche vers le haut	EM01-0007	EM01-0007	EM01-0007	EM01-0007
	Right arrow pictogram Pictogramme flèche vers la droite	EM01-0005	EM01-0005	EM01-0005	EM01-0005
	Left arrow pictogram Pictogramme flèche vers la gauche	EM01-0006	EM01-0006	EM01-0006	EM01-0006

Flag

BODY MAT	DIF MAT		50000h	5
PC	PMMA		L80 B20	MacAdam

Flag

IP	UGR	LOW			
20	<13	FLICKER	90°		

○
14

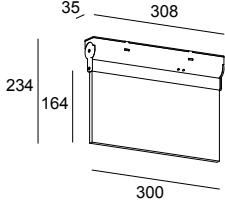

LED K : 4000 CRI : 80 BATTERY : NiCd DISTANCE : 30m						
W	Real Lm Emer.	H. Emer.	Permanent	Auto test	Code	220-240V
3	14	3	Yes	Yes	EM03-0103PA1400	ON-OFF

Star

Star

IP	UGR	LOW		
20	<19	FLICKER		

○
14

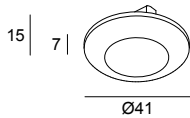
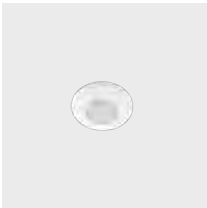

LED K : 4000 CRI : 80 BATTERY : NiCd						
W	Real Lm Emer.	H. Emer.	Permanent	Auto test	Code	220V
0.2	6	3	No	No	EM06-0006NN1400	ON-OFF

65

Deco Track

BODY MAT	DIF MAT		50000h	5
PC	PC		L80 B20	MacAdam

Deco Track Battery NiCd

IP	IK		
20	10		

14

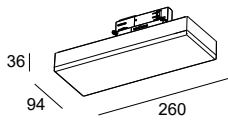

LED | K : 4000 | CRI : 80 | BATTERY : NiCd

W	Real Lm Emer.	H. Emer.	Permanent	Auto test	Code	220-240V
2	200	3	No	No	EM10-0203NN1400	ON-OFF
2	93	3	No	No	EM10-0103NN1400	ON-OFF
2	93	3	No	Yes	EM10-0103NN1401	DALI
2	200	3	No	Yes	EM10-0203NN1401	DALI
3.7	93	3	Yes	No	EM10-0103PN1400	ON-OFF
3.7	93	3	Yes	Yes	EM10-0103PN1401	DALI
4.3	200	3	Yes	No	EM10-0203PN1400	ON-OFF
4.3	200	3	Yes	Yes	EM10-0203PN1401	DALI

Deco Track Battery NiMH

IP	IK		
20	10		

14

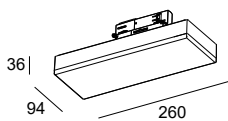

LED | K : 4000 | CRI : 80 | BATTERY : NiMH

W	Real Lm Emer.	H. Emer.	Permanent	Auto test	Code	220-240V
3	280	3	No	No	EM10-0303NN1400	ON-OFF
3	280	3	No	Yes	EM10-0303NA1400	ON-OFF
3	280	3	No	Yes	EM10-0303NN1401	DALI
5.5	280	3	Yes	No	EM10-0303PN1400	ON-OFF
5.5	280	3	Yes	Yes	EM10-0303PA1400	ON-OFF
5.5	280	3	Yes	Yes	EM10-0303PN1401	DALI

Decorative accessories Accessoires décoratifs

	Accessorie Signalling Deco Accessoire Signalisation Deco	EM02-0004	EM02-0004
	Down arrow pictogram Pictogramme flèche vers le bas	EM01-0008	EM01-0008
	Up arrow pictogram Pictogramme flèche vers le haut	EM01-0007	EM01-0007
	Right arrow pictogram Pictogramme flèche vers la droite	EM01-0005	EM01-0005
	Left arrow pictogram Pictogramme flèche vers la gauche	EM01-0006	EM01-0006

Line

An emergency luminaire that's fully integrated in a three-phase track. It allows emergency lighting to be integrated in architectural spaces where, given the type of facility, lighting tracks are visible.

Luminaire de secours totalement intégrable sur le rail triphasé. Permet l'intégration d'un éclairage de secours dans les architectures où le type d'installation nécessite des rails d'éclairage apparents.

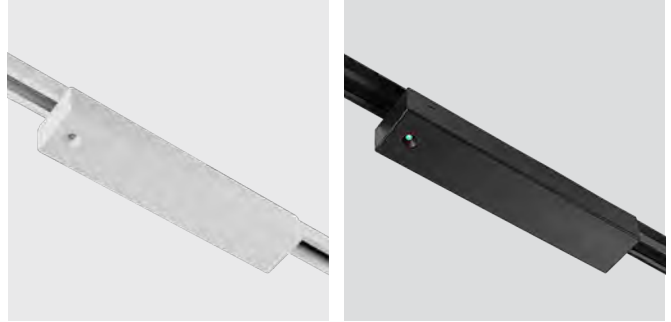

DALI monitoring Surveillance DALI

The DALI versions allow its operational status to be monitored in real time.

Les versions DALI permettent de suivre l'état de fonctionnement du luminaire en temps réel.



Line

BODY MAT PC	DIF MAT AL		50000h L80 B20	4 MacAdam	IP 20	IK 10		
----------------	---------------	--	-------------------	--------------	----------	----------	--	--

○ ●
14 60

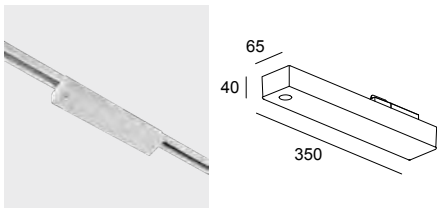

LED K: 5000 CRI: 70 BATTERY: NiMH							
W	Real Lm Emer.	H. Emer.	Permanent	Auto test	Code	220-240V	
1	90	3	No	Yes	EM08-0203NA1400	ON-OFF	
1	90	3	No	Yes	EM08-0203NA6000	ON-OFF	
1	90	3	No	Yes	EM08-0203NA1401	DALI	
1	90	3	No	Yes	EM08-0203NA6001	DALI	



Leco is a surface emergency luminaire that is ideal for lighting areas of transit, such as corridors or communal areas. Its casing has been given a special UV treatment that prevents its materials from yellowing and ensures its perfect condition for longer. This luminaire can be used in its standard mode and emergency mode when any power outage occurs. Leco est un luminaire de secours monté en surface, idéal pour l'éclairage des zones de transit telles que couloirs ou espaces publics. Son corps intègre un traitement UV spécial qui évite le jaunissement des matériaux et garantit un parfait état plus longtemps. Ce luminaire peut être utilisé en mode de fonctionnement standard et en mode de secours en cas de panne électrique.

Leco

BODY MAT	DIF MAT		50000h	3	IP	IK	LOW	
PC	PC		L80 B20	MacAdam	44	10	FLICKER	

○
14



69 |

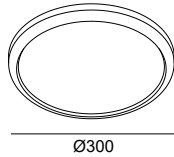

LED | K: 4000 | CRI: 80 | BATTERY: NiCd

W	Real Lm Emer.	H. Emer.	Permanent	Auto test	Code	220-240V
10.5	113	3	Yes	No	15-A003-14-OE	ON-OFF

Leco

IP	IK	LOW		
44	10	FLICKER		

○
14



69 |

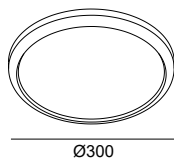

LED | K: 4000 | CRI: 80 | BATTERY: LiFePO4

W	Real Lm Emer.	H. Emer.	Permanent	Auto test	Code	220-240V
12	200	3	Yes	Yes	15-A003-14-DE	DALI

Play

Designed by LedsC4 Architectural



+ Play

Spotlight
P. 283



Downlight
P. 184



Pendant
P. 271



Ceiling
P. 283



A collection of downlights offering high modularity and excellent features. Both the standard and emergency versions allow you to add and combine an LED module with a wide variety of trims and accessories so that you can obtain a customised downlight adapted to each project's requirements.

Collection de downlights offrant une grande modularité et de nombreuses prestations. Les versions standard et de secours permettent d'ajouter et de combiner un module LED avec une grande variété de collerettes et d'accessoires, obtenant ainsi un downlight personnalisé adapté aux besoins de chaque projet.

This is a luminaire status signalling system, patented by LEDS C4, with the emergency indicator included in the lens itself, therefore offering the project greater standardisation.

Système de signalisation de l'état des luminaires breveté par LEDS C4 avec le voyant d'urgence inclus dans la lentille même, pour une plus grande homogénéité du projet.



The DALI self-test kit enables real-time monitoring of the luminaires' operation.

Le kit autotest DALI permet le monitoring en temps réel du fonctionnement des luminaires.

Play
Flat Emergency

BODY MAT
PC,AL



















50000h
L80 B20

2
MacAdam

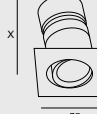

Code example / Exemple d'élaboration d'une référence: **AG11-P7V9M20114**

Model	W	K / CRI / Real Lm.	Optics	Source	Finishes
 <p>AG11 - Round / Fixed Rond / Fixe ☂ 0-7 mm Ⓜ 58 IP54</p> <p>○ ● 14 60</p> 	P7 8.5W	V9 2700K / CRI 90 / 582 Lm.	M2 28°	O1  Emergency ON-OFF 1H 220-240V	14  60  AF 
		W9 3000K / CRI 90 / 663 Lm.		O3  Emergency ON-OFF 3H 220-240V	
		X9 4000K / CRI 90 / 674 Lm.		D1  Emergency DALI-2 1H 220-240V	
 <p>AG12 - Round / Adjustable Rond / Ajustable ☂ 0-20 mm Ⓜ 68 IP23</p> <p>○ ● ● 14 60 AF</p> 	13 14.3W	V9 2700K / CRI 90 / 960 Lm.	M2 34°	O1  Emergency ON-OFF 1H 220-240V	
		W9 3000K / CRI 90 / 1305 Lm.		O3  Emergency ON-OFF 3H 220-240V	
		X9 4000K / CRI 90 / 1397 Lm.		D1  Emergency DALI-2 1H 220-240V	
 <p>AG19 - Square / Fixed Carré / Fixe ☂ 0-7 mm Ⓜ 58 IP54</p> <p>○ ● 14 60</p> 					
 <p>AG21 - Square / Adjustable Carré / Ajustable ☂ 0-20 mm Ⓜ 68 IP23</p> <p>○ ● 14 60</p> 					

Play Deep Emergency

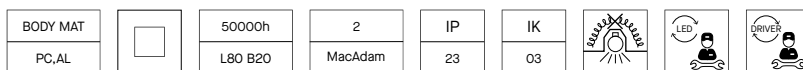





Code exemple / Exemple d'élaboration d'une référence: **AG15-P7V9M20114**

Model	W	K / CRI / Real Lm.	Optics	Source	Finishes
 AG15 - Round / Fixed Rond / Fixe 0-20 mm 58 IP54 	P7 8.5W	V9 2700K / CRI 90 / 543 Lm.	M2 27°	O1 Emergency ON-OFF 1H 220-240V	14 60
		W9 3000K / CRI 90 / 548 Lm.		O3 Emergency ON-OFF 3H 220-240V	
		X9 4000K / CRI 90 / 628 Lm.		D1 Emergency DALI-2 1H 220-240V	
 AG17 - Round / Adjustable / Trimless Rond / Ajustable / Sans Colerette 0-18 mm 75 IP23 	13 14.3W	V9 2700K / CRI 90 / 1110 Lm.	M2 33°	O1 Emergency ON-OFF 1H 220-240V	14 60
		W9 3000K / CRI 90 / 1195 Lm.		O3 Emergency ON-OFF 3H 220-240V	
		X9 4000K / CRI 90 / 1278 Lm.		D1 Emergency DALI-2 1H 220-240V	
				D3 Emergency DALI-2 3H 220-240V	

Play High Visual Comfort Emergency



Code exemple / Exemple d'élaboration d'une référence: **AG13-P7V9M20114**

Model	W	K / CRI / Real Lm.	Optics	Source	Finishes
 AG13 - Round / Fixed Rond / Fixe 0-25 mm 78 IP54 	P7 8.5W	V9 2700K / CRI 90 / 565 Lm.	M2 28°	O1 Emergency ON-OFF 1H 220-240V	14 60
		W9 3000K / CRI 90 / 606 Lm.		O3 Emergency ON-OFF 3H 220-240V	
		X9 4000K / CRI 90 / 626 Lm.		D1 Emergency DALI-2 1H 220-240V	
 AG14 - Round / Adjustable Rond / Ajustable 0-18 mm 90 IP23 	13 14.3W	V9 2700K / CRI 90 / 1216 Lm.	M2 34°	O1 Emergency ON-OFF 1H 220-240V	14 60
		W9 3000K / CRI 90 / 1216 Lm.		O3 Emergency ON-OFF 3H 220-240V	
		X9 4000K / CRI 90 / 1302 Lm.		D1 Emergency DALI-2 1H 220-240V	
				D3 Emergency DALI-2 3H 220-240V	

Play IP65 Emergency

BODY MAT PC,AL		50000h L80 B20	2 MacAdam	IP 65	IK 03	DIF MAT GLA			
-------------------	--	-------------------	--------------	----------	----------	----------------	--	--	--

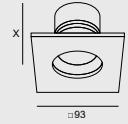

Code example / Exemple d'élaboration d'une référence: **AG16-P7V9M20114**

Model	W	K / CRI / Real Lm.	Optics	Source	Finishes	
 <p>AG16 - Round / Fixed Rond / Fixe 0-20 mm 65 IP65</p>  <p>14 60 21</p>	P7 8.5W	V9 2700K / CRI 90 / 543 Lm.	M2 28°	O1 Emergency ON-OFF 1H 220-240V	14	
		W9 3000K / CRI 90 / 595 Lm.		O3 Emergency ON-OFF 3H 220-240V		60
		X9 4000K / CRI 90 / 629 Lm.		D1 Emergency DALI-2 1H 220-240V		21
 <p>AG22 - Square / Fixed Carré / Fixe 0-20 mm 65 IP65</p>  <p>14 60</p>	13 14.3W	V9 2700K / CRI 90 / 1161 Lm.	M2 34°	O1 Emergency ON-OFF 1H 220-240V		
		W9 3000K / CRI 90 / 1161 Lm.		O3 Emergency ON-OFF 3H 220-240V		
		X9 4000K / CRI 90 / 1242 Lm.		D1 Emergency DALI-2 1H 220-240V		
				D3 Emergency DALI-2 3H 220-240V		

Play IP65 Glass Emergency

BODY MAT PC,AL		50000h L80 B20	2 MacAdam	IP 65	IK 03	DIF MAT GLA			
-------------------	--	-------------------	--------------	----------	----------	----------------	--	--	--

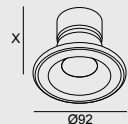
Code example / Exemple d'élaboration d'une référence: **AG43-P7V9M20114**

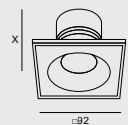
Model	W	K / CRI / Real Lm.	Optics	Source	Finishes
 <p>AG43 - Round / Fixed Rond / Fixe 0-20 mm 68 IP65</p>  <p>Ø92</p>	P7 8.5W	V9 2700K / CRI 90 / 514 Lm.	M2 28°	O1 Emergency ON-OFF 1H 220-240V	14
		W9 3000K / CRI 90 / 595 Lm.		O3 Emergency ON-OFF 3H 220-240V	
		X9 4000K / CRI 90 / 595 Lm.		D1 Emergency DALI-2 1H 220-240V	
 <p>AG44 - Square / Fixed Carré / Fixe 0-20 mm 68 IP65</p>  <p>Ø92</p>	13 14.3W	V9 2700K / CRI 90 / 922 Lm.	M2 34°	O1 Emergency ON-OFF 1H 220-240V	
		W9 3000K / CRI 90 / 1176 Lm.		O3 Emergency ON-OFF 3H 220-240V	
		X9 4000K / CRI 90 / 1258 Lm.		D1 Emergency DALI-2 1H 220-240V	
				D3 Emergency DALI-2 3H 220-240V	



Play
Pinhole Emergency

BODY MAT
PC,AL



50000h
L80 B20



2
MacAdam

IP
23

IK
03

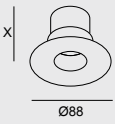
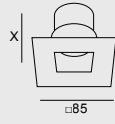
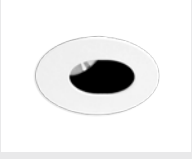
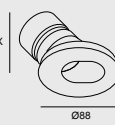

Code example / Exemple d'élaboration d'une référence: **AG45-P7V9M20114**

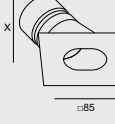
Model	W	K / CRI / Real Lm.	Optics	Source	Finishes
 <p>AG45 - Round / Fixed Rond / Fixe ☞ 0-18 mm Ⓜ 75 IP54</p> 	P7 8.5W	V9 2700K / CRI 90 / 304 Lm.	M2 32°	O1 Emergency ON-OFF 1H 220-240V	14
		W9 3000K / CRI 90 / 364 Lm.		O3 Emergency ON-OFF 3H 220-240V	
		X9 4000K / CRI 90 / 368 Lm.		D1 Emergency DALI-2 1H 220-240V	
 <p>AG46 - Square / Fixed Carré / Fixe ☞ 0-18 mm Ⓜ 75 IP54</p> 	13 14.3W	V9 2700K / CRI 90 / 1070 Lm.	M2 32°	O1 Emergency ON-OFF 1H 220-240V	
		W9 3000K / CRI 90 / 1138 Lm.		O3 Emergency ON-OFF 3H 220-240V	
		X9 4000K / CRI 90 / 1230 Lm.		D1 Emergency DALI-2 1H 220-240V	
 <p>AG47 - Round / Adjustable Rond / Ajustable ☞ 0-18 mm Ⓜ 75 IP23</p> 				D3 Emergency DALI-2 3H 220-240V	
 <p>AG48 - Square / Adjustable Carré / Ajustable ☞ 0-18 mm Ⓜ 75 IP23</p> 					

Play
Soft Emergency

BODY MAT
PC,AL



50000h
L80 B20

2
MacAdam

IP
23











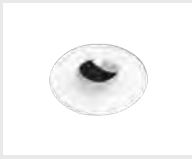
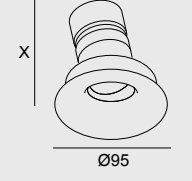

IK
03

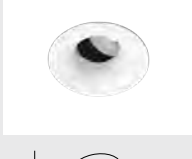
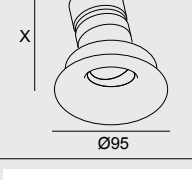

35°

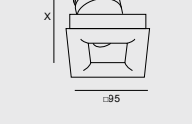

Code exemple / Exemple d'élaboration d'une référence: **AG52-P7V9M20114**

Model	W	K / CRI / Real Lm.	Optics	Source	Finishes
 AG52 - Round / Adjustable Rond / Ajustable 0-18 mm Φ 86 IP23 	P7 8.5W	V9 2700K / CRI 90 / 332 Lm.	M2 33°	O1  Emergency ON-OFF 1H 220-240V	14  60 
		W9 3000K / CRI 90 / 386 Lm.		O3  Emergency ON-OFF 3H 220-240V	
		X9 4000K / CRI 90 / 504 Lm.		D1  Emergency DALI-2 1H 220-240V D3  Emergency DALI-2 3H 220-240V	
 AG53 - Round / Adjustable / Trimless Rond / Ajustable / Sans Colerette 0-18 mm Φ 102 IP23 	13 14.3W	V9 2700K / CRI 90 / 900 Lm.	M2 34°	O1  Emergency ON-OFF 1H 220-240V	
		W9 3000K / CRI 90 / 1271 Lm.		O3  Emergency ON-OFF 3H 220-240V	
		X9 4000K / CRI 90 / 1360 Lm.		D1  Emergency DALI-2 1H 220-240V D3  Emergency DALI-2 3H 220-240V	
 AG55 - Square / Adjustable Carré / Ajustable 0-18 mm \square 85x85 IP23 					

Play Snoot Emergency

BODY MAT		50000h	2	IP	IK					
PC,AL		L80 B20	MacAdam	23	03		40°	320°		

Code example / Exemple d'élaboration d'une référence: **AG56-P7V9M20114**

Model	W	K / CRI / Real Lm.	Optics	Source	Finishes
 AG56 - Round / Adjustable Rond / Ajustable 0-18 mm 85 IP23 ↕ 40° ↔320°  Ø95	P7 8.5W	V9 2700K / CRI 90 / 507 Lm.	M2 27°	O1 Emergency ON-OFF 1H 220-240V	14 60
		W9 3000K / CRI 90 / 590 Lm.		O3 Emergency ON-OFF 3H 220-240V	
		X9 4000K / CRI 90 / 590 Lm.		D1 Emergency DALI-2 1H 220-240V	
 AG57 - Round / Adjustable / Trimless Rond / Ajustable / Sans Colerette 0-18 mm 87 IP23 ↕ 40° ↔320°  Ø86	13 14.3W	V9 2700K / CRI 90 / 1131 Lm.	M2 34°	O1 Emergency ON-OFF 1H 220-240V	14 60
		W9 3000K / CRI 90 / 1203 Lm.		O3 Emergency ON-OFF 3H 220-240V	
		X9 4000K / CRI 90 / 1300 Lm.		D1 Emergency DALI-2 1H 220-240V	
				D3 Emergency DALI-2 3H 220-240V	

Play Raw Emergency

BODY MAT		50000h	2	IP	IK					
PC,AL		L80 B20	MacAdam	54	03					

Code example / Exemple d'élaboration d'une référence: **AG59-P7V9M20155**

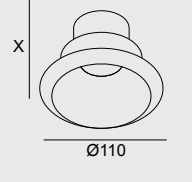
Model	W	K / CRI / Real Lm.	Optics	Source	Finishes
 AG59 - Round / Fixed Rond / Fixe 0-25 mm 100 IP54  Ø110	P7 8.5W	V9 2700K / CRI 90 / 535 Lm.	M2 32°	O1 Emergency ON-OFF 1H 220-240V	55 EN EO DC
		W9 3000K / CRI 90 / 601 Lm.		O3 Emergency ON-OFF 3H 220-240V	
		X9 4000K / CRI 90 / 604 Lm.		D1 Emergency DALI-2 1H 220-240V	
	13 14.3W	V9 2700K / CRI 90 / 1175 Lm.	M2 34°	O1 Emergency ON-OFF 1H 220-240V	
		W9 3000K / CRI 90 / 1250 Lm.		O3 Emergency ON-OFF 3H 220-240V	
		X9 4000K / CRI 90 / 1350 Lm.		D1 Emergency DALI-2 1H 220-240V	
				D3 Emergency DALI-2 3H 220-240V	

Play
Raw Racy Gold Emergency

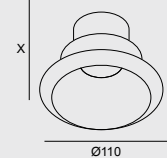

Code exemple / Exemple d'élaboration d'une référence: **AG58-P7V9M201EP**

Model	W	K / CRI / Real Lm.	Optics	Source	Finishes
 <p>AG58 - Round / Fixed Rond / Fixe 0-25 mm 100 IP54</p> 	P7 8.5W	V9 2700K / CRI 90 / 539 Lm.	M2 28°	O1 Emergency ON-OFF 1H 220-240V	EP
		W9 3000K / CRI 90 / 624 Lm.		O3 Emergency ON-OFF 3H 220-240V	
		X9 4000K / CRI 90 / 624 Lm.		D1 Emergency DALI-2 1H 220-240V	
	13 14.3W	V9 2700K / CRI 90 / 1125 Lm.	M2 34°	D3 Emergency DALI-2 3H 220-240V	
		W9 3000K / CRI 90 / 1211 Lm.		O1 Emergency ON-OFF 1H 220-240V	
		X9 4000K / CRI 90 / 1296 Lm.		O3 Emergency ON-OFF 3H 220-240V	
				D1 Emergency DALI-2 1H 220-240V	
				D3 Emergency DALI-2 3H 220-240V	



EMERGENCY LIGHTING

Play Flat 7W Emergency

Play Flat 13W Emergency











Lens accessories
Accessoires optiques

	Halo fader (5u.) Diffuseur de halo (5 u.)		71-6099-00-00	71-6099-00-00
	Visual comfort (1u.) Confort visuel (1 u.)	14 ○	71-4754-14-00	71-4754-14-00
		60 ●	71-4754-60-00	71-4754-60-00
	Screen (5u.) Diffuseur (5 u.)	60 ●	71-7895-60-00	71-7895-60-00

Play Deco Symmetrical Trim Emergency

BODY MAT PC,AL		50000h L80 B20	2 MacAdam	IP 54	IK 03			
-------------------	----------------------------------------------------------------------------------	-------------------	--------------	----------	----------	------------------------------------------------------------------------------------	------------------------------------------------------------------------------------	------------------------------------------------------------------------------------

Code example / Exemple d'élaboration d'une référence: **AG23-P7V9M201WR**

Model	W	K / CRI / Real Lm.	Optics	Source	Finishes
 AG23 - Round / Fixed Rond / Fixe Ø 0-25 mm Ⓢ 80 IP54 	P7 8.5W	V9 2700K / CRI 90 / 571 Lm.	M2 28°	O1  Emergency ON-OFF 1H 220-240V	     
		W9 3000K / CRI 90 / 624 Lm.		O3  Emergency ON-OFF 3H 220-240V	
		X9 4000K / CRI 90 / 637 Lm.		D1  Emergency DALI-2 1H 220-240V	
 AG27 - Square / Fixed Carré / Fixe 0-25 mm Ⓢ 100 IP54 	13 14.3W	V9 2700K / CRI 90 / 907 Lm.	M2 34°	O1  Emergency ON-OFF 1H 220-240V	  
		W9 3000K / CRI 90 / 1271 Lm.		O3  Emergency ON-OFF 3H 220-240V	
		X9 4000K / CRI 90 / 1424 Lm.		D1  Emergency DALI-2 1H 220-240V	
				D3  Emergency DALI-2 3H 220-240V	

Play Deco Symmetrical Trimless Emergency

BODY MAT PC,AL		50000h L80 B20	2 MacAdam	IP 54	IK 03			
-------------------	-------------------------------------------------------------------------------------	-------------------	--------------	----------	----------	---------------------------------------------------------------------------------------	---------------------------------------------------------------------------------------	---------------------------------------------------------------------------------------

Code example / Exemple d'élaboration d'une référence: **AG24-P7V9M201WP**

Model	W	K / CRI / Real Lm.	Optics	Source	Finishes
 AG24 - Round / Fixed / Trimless Rond / Fixe / Sans Collettere 0-15 mm Ⓢ 75 IP54 	P7 8.5W	V9 2700K / CRI 90 / 571 Lm.	M2 28°	O1  Emergency ON-OFF 1H 220-240V	  
		W9 3000K / CRI 90 / 624 Lm.		O3  Emergency ON-OFF 3H 220-240V	
		X9 4000K / CRI 90 / 637 Lm.		D1  Emergency DALI-2 1H 220-240V	
 AG28 - Square / Fixed / Trimless Carré / Fixe / Sans Collettere 0-25 mm Ⓢ 75x75 IP54 	13 14.3W	V9 2700K / CRI 90 / 1181 Lm.	M2 34°	O1  Emergency ON-OFF 1H 220-240V	
		W9 3000K / CRI 90 / 1271 Lm.		O3  Emergency ON-OFF 3H 220-240V	
		X9 4000K / CRI 90 / 1360 Lm.		D1  Emergency DALI-2 1H 220-240V	
				D3  Emergency DALI-2 3H 220-240V	

Play Deco Asymmetrical Trim Emergency

BODY MAT		50000h	2	IP	IK			
PC,AL		L80 B20	MacAdam	54	03			

Code exemple / Exemple d'élaboration d'une référence: **AG25-P7V9M2O1WR**

Model	W	K / CRI / Real Lm.	Optics	Source	Finishes
 AG25 - Round / Fixed Rond / Fixe 0-25 mm IP54  Ø90	P7 8.5W	V9 2700K / CRI 90 / 528 Lm.	M2 27°	O1  Emergency ON-OFF 1H 220-240V	WR 
		W9 3000K / CRI 90 / 527 Lm.		O3  Emergency ON-OFF 3H 220-240V	WG 
		X9 4000K / CRI 90 / 558 Lm.		D1  Emergency DALI-2 1H 220-240V	WH 
				D3  Emergency DALI-2 3H 220-240V	WI 
					WJ 
					WK 
 AG29 - Square / Fixed Carré / Fixe 0-25 mm IP54  □101	13 14.3W	V9 2700K / CRI 90 / 801 Lm.	M2 34°	O1  Emergency ON-OFF 1H 220-240V	WL 
		W9 3000K / CRI 90 / 1271 Lm.		O3  Emergency ON-OFF 3H 220-240V	WM 
		X9 4000K / CRI 90 / 1424 Lm.		D1  Emergency DALI-2 1H 220-240V	WN 
				D3  Emergency DALI-2 3H 220-240V	

Play Deco Asymmetrical Trimless Emergency

BODY MAT		50000h	2	IP	IK			
PC,AL		L80 B20	MacAdam	54	03			

Code exemple / Exemple d'élaboration d'une référence: **AG26-P7V9M2O1WP**

Model	W	K / CRI / Real Lm.	Optics	Source	Finishes
 AG26 - Round / Fixed / Trimless Rond / Fixe / Sans Colerette 0-15 mm IP54  Ø74	P7 8.5W	V9 2700K / CRI 90 / 528 Lm.	M2 27°	O1  Emergency ON-OFF 1H 220-240V	WP 
		W9 3000K / CRI 90 / 527 Lm.		O3  Emergency ON-OFF 3H 220-240V	WS 
		X9 4000K / CRI 90 / 558 Lm.		D1  Emergency DALI-2 1H 220-240V	WQ 
				D3  Emergency DALI-2 3H 220-240V	
 AG31 - Square / Fixed / Trimless Carré / Fixe / Sans Colerette 0-25 mm IP54  □74	13 14.3W	V9 2700K / CRI 90 / 1086 Lm.	M2 34°	O1  Emergency ON-OFF 1H 220-240V	
		W9 3000K / CRI 90 / 1169 Lm.		O3  Emergency ON-OFF 3H 220-240V	
		X9 4000K / CRI 90 / 1251 Lm.		D1  Emergency DALI-2 1H 220-240V	
				D3  Emergency DALI-2 3H 220-240V	

Play Deco
Asymmetrical
Trim 7W
Emergency

Play Deco
Asymmetrical
Trim 13W
Emergency

Play Deco
Asymmetrical
Trimless 7W
Emergency

Play Deco
Asymmetrical
Trimless 13W
Emergency



Lens accessories
Accessoires optiques



Halo fader (5u.)
Diffuseur de halo (5 u.)

71-6099-00-00 71-6099-00-00 71-6099-00-00 71-6099-00-00



Visual comfort (1u.)
Confort visuel (1 u.)

14 ○

71-4754-14-00 71-4754-14-00 71-4754-14-00 71-4754-14-00

60 ●

71-4754-60-00 71-4754-60-00 71-4754-60-00 71-4754-60-00



Screen (5u.)
Diffuseur (5 u.)

60 ●

71-7895-60-00 71-7895-60-00 71-7895-60-00 71-7895-60-00

Play Deco
Symmetrical
Trim 7W
Emergency

Play Deco
Symmetrical
Trim 13W
Emergency

Play Deco
Symmetrical
Trimless 7W
Emergency

Play Deco
Symmetrical
Trimless 13W
Emergency



Lens accessories
Accessoires optiques



Halo fader (5u.)
Diffuseur de halo (5 u.)

71-6099-00-00 71-6099-00-00 71-6099-00-00 71-6099-00-00



Visual comfort (1u.)
Confort visuel (1 u.)

14 ○

71-4754-14-00 71-4754-14-00 71-4754-14-00 71-4754-14-00

60 ●

71-4754-60-00 71-4754-60-00 71-4754-60-00 71-4754-60-00



Screen (5u.)
Diffuseur (5 u.)

60 ●

71-7895-60-00 71-7895-60-00 71-7895-60-00 71-7895-60-00

Infinite Pro

Designed by LedsC4 Architectural



+ Infinite

Lineal Light
P. 338

Low Voltage
P. 132

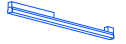

EMERGENCY LIGHTING

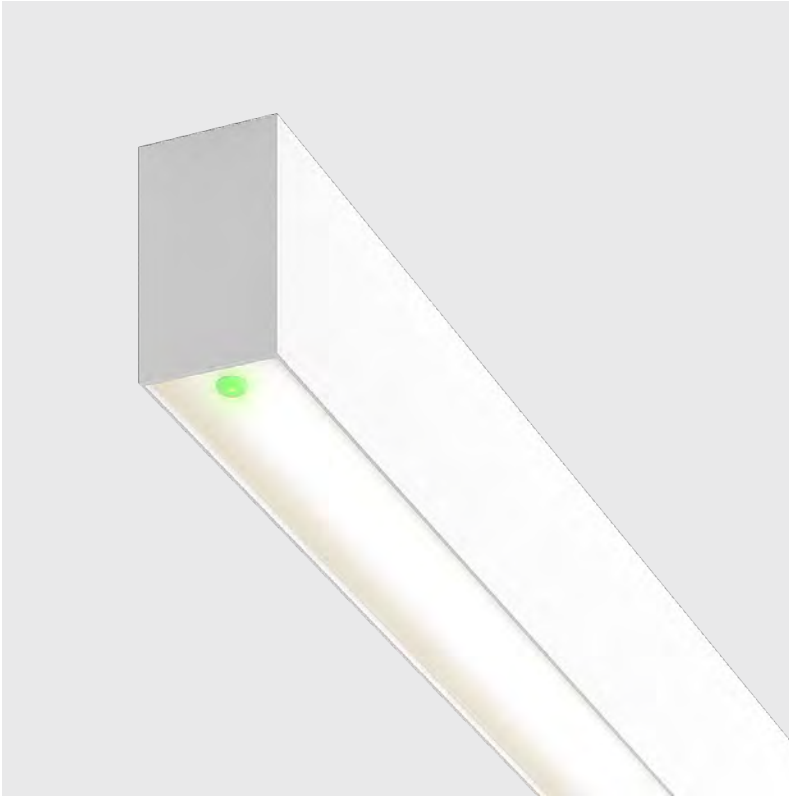

Infinite Pro is the perfect solution to light spaces requiring high levels of comfort, offering lighting designed to improve the well-being of both people and companies, especially in offices or workspaces where lighting quality is essential. Infinite Pro emergency includes the signalling LED in the luminaire, for which reason installation is much easier and doesn't require additional elements.

Infinite Pro est la solution parfaite pour éclairer des espaces qui exigent un haut niveau de confort, offrant un éclairage conçu pour améliorer le bien-être des personnes et des entreprises, en particulier dans les bureaux et espaces de travail où la qualité de la lumière est fondamentale. Infinite Pro de secours comprend la LED de signalisation dans le luminaire, ce qui facilite grandement son installation et n'exige aucun élément supplémentaire.

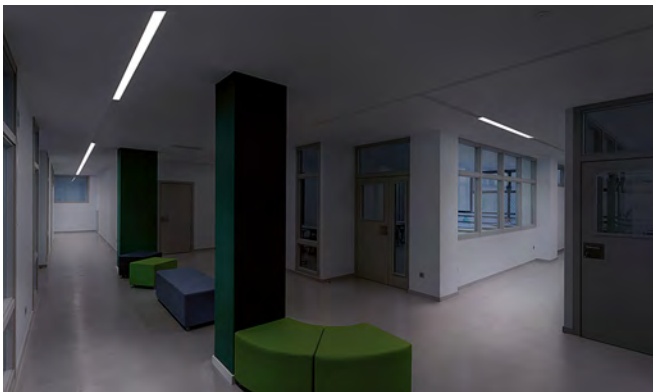

DALI monitoring Surveillance DALI

Real-time knowledge of the luminaires' status.
Connaissance en temps réel de l'état des luminaires.

Infinite Pro
Opal Emergency

BODY MAT
AL

DIF MAT
PC



50000h
L80 B20











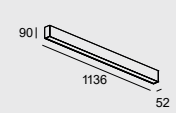
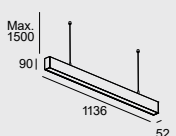
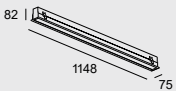
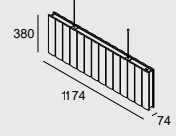

3
MacAdam

IP
40

UGR
<10

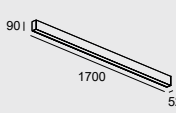
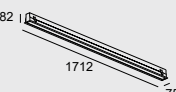
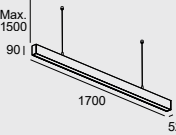

Code example / Exemple d'élaboration d'une référence: **AK14-34W8PMO314**

Model	W	K / CRI / Real Lm.	Optics	Source	Finishes	
1136 mm  AK14 - Surface Surface IP40  AK15 - Pendant Suspendue IP40  AK16 - Recessed Encastré 0-25 mm 1140x65 IP44  AK23 - Pendant / Acoustic Suspendue / Acoustique IP40	   14 60 N3	34 33.7W W8 3000K / CRI 80 / 1290 Lm. W9 3000K / CRI 90 / 1152 Lm. X8 4000K / CRI 80 / 4079 Lm. X9 4000K / CRI 90 / 3143 Lm.	PM Opal	O3 On-Off Emerg. D3 DALI Emerg.	14  60  N3  GA  GB 	
	1700 mm  AK18 - Surface Surface IP40  AK19 - Recessed Encastré 0-25 mm 1705x65 IP40  AK21 - Pendant Suspendue IP40	   14 60 N3	52 50.6W W8 3000K / CRI 80 / 1965 Lm. W9 3000K / CRI 90 / 1755 Lm. X8 4000K / CRI 80 / 6264 Lm. X9 4000K / CRI 90 / 4827 Lm.	PM Opal	O3 On-Off Emerg. D3 DALI Emerg.	(Same as above)

BODY MAT
AL

DIF MAT
PC



50000h
L80 B20

3
MacAdam

IP
40

UGR
<10



Code example / Exemple d'élaboration d'une référence: **AK14-34W8HC0314**

Model		W	K / CRI / Real Lm.	Optics	Source	Finishes	
1136 mm	 AK14 - Surface Surface IP40	 14 60 N3	34 33.7W	W8 3000K / CRI 80 / 1290 Lm. W9 3000K / CRI 90 / 1152 Lm. X8 4000K / CRI 80 / 4079 Lm. X9 4000K / CRI 90 / 3143 Lm.	HC Hexa-Cell	O3 On-Off Emerg. D3 DALI Emerg.	14 60 N3 GA GB
	 AK15 - Pendant Suspendue IP40	 14 60 N3					
	 AK16 - Recessed Encastré 0-25 mm 1140x65 IP44	 14					
	 AK23 - Pendant / Acoustic Suspendue / Acoustique IP40	 GA GB					
1700 mm	 AK18 - Surface Surface IP40	 14 60 N3	52 50.6W	W8 3000K / CRI 80 / 1965 Lm. W9 3000K / CRI 90 / 1755 Lm. X8 4000K / CRI 80 / 6264 Lm. X9 4000K / CRI 90 / 4827 Lm.	HC Hexa-Cell	O3 On-Off Emerg. D3 DALI Emerg.	
	 AK19 - Recessed Encastré 0-25 mm 1705x65 IP40	 14					
	 AK21 - Pendant Suspendue IP40	 14 60 N3					

Infinite Pro
Opal 1136mm
Surface



Infinite Pro
Opal 1136mm
Suspended



Infinite Pro
Opal 1700mm
Recessed



Infinite Pro
Opal 1700mm
Suspended



Power supplies

Sources d'alimentation



Emergency suspended ceiling rose with electrical outlet
Patère suspendue avec prise de courant
Emergency

14 ○

71-A223-14-00

-

-

-

DALI Emergency power supply
Source d'alimentation DALI de secours

14 ○

-

-

71-A228-14-00

-

DALI Emergency power supply
Source d'alimentation DALI de secours

60 ●

71-A228-60-00

-

-

71-A228-60-00

DALI Emergency power supply
Source d'alimentation DALI de secours

N3 ○

-

71-A228-N3-00

-

71-A228-N3-00

Lens accessories

Accessoires optiques



Microprismatic diffuser
Diffuseur microprismatique

-

71-A939-00-00

71-A940-00-00

71-A940-00-00

Joint accessories

Accessoires de raccord



DALI "I" union kit
Kit de raccord en « I » DALI





71-A955-00-DA

71-A955-00-DA

71-A955-00-DA

71-A955-00-DA



Infinite Pro Hexa-Cell 1136mm Suspended	Infinite Pro Hexa-Cell 1136mm Recessed	Infinite Pro Opal 1136mm Suspended Acoustic	Infinite Pro Opal 1700mm Surface	Infinite Pro Opal 1136mm Recessed
				

Power supplies Sources d'alimentation





	Emergency suspended ceiling rose with electrical outlet Patère suspendue avec prise de courant Emergency	14 ○	-	-	-	71-A223-14-00	-
	DALI Emergency power supply Source d'alimentation DALI de secours	14 ○	-	71-A228-14-00	-	-	71-A228-14-00
	DALI Emergency power supply Source d'alimentation DALI de secours	60 ●	-	-	-	-	-
	DALI Emergency power supply Source d'alimentation DALI de secours	N3 ○	71-A228-N3-00	-	-	-	-

Lens accessories Accessoires optiques

	Microprismatic diffuser Diffuseur microprismatique		71-A939-00-00	71-A939-00-00	71-A939-00-00	-	71-A939-00-00
-----------------------------------------------------------------------------------	-------------------------------------------------------	--	---------------	---------------	---------------	---	---------------

Joint accessories Accessoires de raccord

	DALI "I" union kit Kit de raccord en « I » DALI		71-A955-00-DA	71-A955-00-DA	71-A955-00-DA	71-A955-00-DA	71-A955-00-DA
-------------------------------------------------------------------------------------	----------------------------------------------------	--	---------------	---------------	---------------	---------------	---------------

Infinite Pro Hexa-Cell 1136mm Surface	Infinite Pro Hexa-Cell 1700mm Surface	Infinite Pro Hexa-Cell 1700mm Recessed	Infinite Pro Hexa-Cell 1136mm Suspended Acoustic	Infinite Pro Hexa-Cell 1700mm Suspended
				

Power supplies

Sources d'alimentation

	Emergency suspended ceiling rose with electrical outlet Patère suspendue avec prise de courant Emergency	14 ○	71-A223-14-00	71-A223-14-00	-	-	-
	DALI Emergency power supply Source d'alimentation DALI de secours	14 ○	-	-	71-A228-14-00	-	-
	DALI Emergency power supply Source d'alimentation DALI de secours	60 ●	71-A228-60-00	-	-	-	71-A228-60-00
	DALI Emergency power supply Source d'alimentation DALI de secours	N3 ●	-	-	-	-	71-A228-N3-00

Lens accessories

Accessoires optiques

	Microprismatic diffuser Diffuseur microprismatique		-	-	71-A940-00-00	71-A939-00-00	71-A940-00-00
-----------------------------------------------------------------------------------	-------------------------------------------------------	--	---	---	----------------------	----------------------	----------------------

Joint accessories

Accessoires de raccord

	DALI "I" union kit Kit de raccord en « I » DALI		71-A955-00-DA	71-A955-00-DA	71-A955-00-DA	71-A955-00-DA	71-A955-00-DA
-------------------------------------------------------------------------------------	----------------------------------------------------	--	----------------------	----------------------	----------------------	----------------------	----------------------

Bento

Designed by LedsC4 Architectural



Low Voltage
P. 126

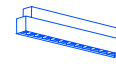

Downlights
P. 232



Ceiling
P. 309



EMERGENCY LIGHTING

This collection of linear downlights is the result of a long study carried out by LedsC4's product developers in a bid to obtain a luminaire that offers high visual comfort and optimal performance. Its emergency version allows the project to be more homogeneous and anti-panic lighting can also be generated using the same luminaire model.

Fruit d'une longue étude des techniciens de LEDS C4, cette collection de downlights linéaires vise à proposer un produit alliant confort visuel élevé et performances optimales. Sa version de secours confère une plus grande homogénéité aux projets tout en générant un éclairage antipanique dans un même modèle de luminaire.

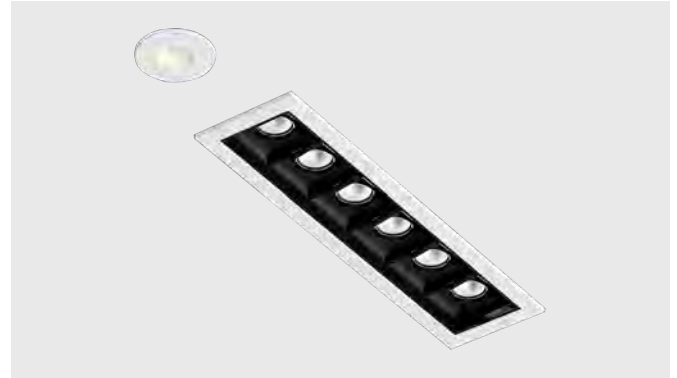

Bento Standard 3 LEDs Trim

BODY MAT		50000h	3	IP	WELL			
PC,AL		L80 B20	MacAdam	23				

○ ●
14 60

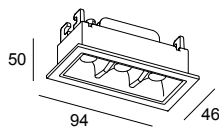

40x89 0-18 mm

LED | K : 2700 | CRI : 90 | BATTERY : NiCd

W	Real Lm. Emer.	Optics	H. Emer.	Permanent	Auto test	Code	220-240V	
6.1	106	18°	3	Yes	No	90-6364	14	OE ON-OFF
6.1	110	38°	3	Yes	No	90-6366	60	DE DALi
6.1	100	47°	3	Yes	No	90-6368		

Bento Standard 3 LEDs Trim

BODY MAT		50000h	3	IP	WELL			
PC,AL		L80 B20	MacAdam	23				

○ ●
14 60

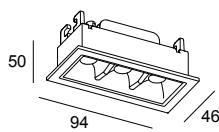

40x89 0-18 mm

LED | K : 3000 | CRI : 90 | BATTERY : NiCd

W	Real Lm. Emer.	Optics	H. Emer.	Permanent	Auto test	Code	220-240V	
6.1	106	18°	3	Yes	No	90-6365	14	OE ON-OFF
6.1	110	38°	3	Yes	No	90-6367	60	DE DALi
6.1	100	47°	3	Yes	No	90-6369		

Bento Standard 3 LEDS Trim

BODY MAT		50000h	3	IP	WELL			
PC,AL		L80 B20	MacAdam	23				

○ ●
14 60

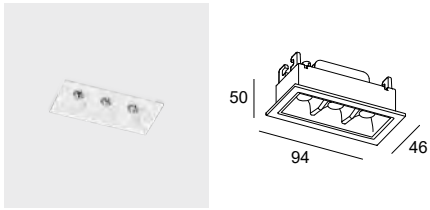

LED | K: 4000 | CRI: 90 | BATTERY: NiCd

W	Real Lm. Emer.	Optics	H. Emer.	Permanent	Auto test	Code	220-240V		
6.1	117	18°	3	Yes	No	90-6673	- 14 - 60	- OE - DE	ON-OFF DALI
6.1	122	38°	3	Yes	No	90-6674			
6.1	110	47°	3	Yes	No	90-6675			

40x168 0-18 mm

Bento Standard 6 LEDS Trim

BODY MAT		50000h	3	IP	WELL			
PC,AL		L80 B20	MacAdam	23				

○ ●
14 60

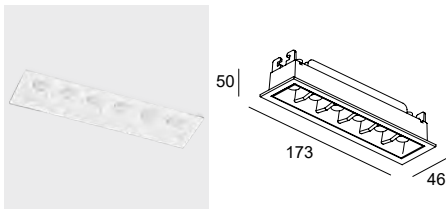

LED | K: 2700 | CRI: 90 | BATTERY: NiCd

W	Real Lm. Emer.	Optics	H. Emer.	Permanent	Auto test	Code	220-240V		
12.2	117	18°	3	Yes	No	90-6370	- 14 - 60	- OE - DE	ON-OFF DALI
12.2	110	38°	3	Yes	No	90-6372			
12.2	104	47°	3	Yes	No	90-6374			

40x168 0-18 mm

Bento Standard 6 LEDS Trim

BODY MAT		50000h	3	IP	WELL			
PC,AL		L80 B20	MacAdam	23				

○ ●
14 60

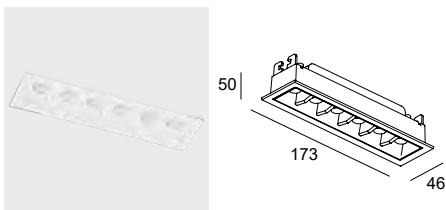

LED | K: 3000 | CRI: 90 | BATTERY: NiCd

W	Real Lm. Emer.	Optics	H. Emer.	Permanent	Auto test	Code	220-240V		
12.2	117	18°	3	Yes	No	90-6371	- 14 - 60	- OE - DE	ON-OFF DALI
12.2	110	38°	3	Yes	No	90-6373			
12.2	104	47°	3	Yes	No	90-6375			

40x168 0-18 mm

Bento Standard 6 LEDS Trim

BODY MAT		50000h	3	IP	WELL			
PC,AL		L80 B20	MacAdam	23				

○ ●
14 60

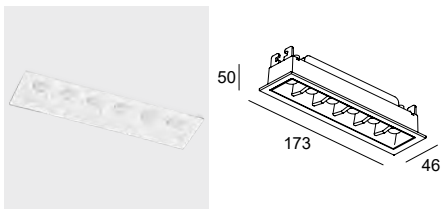

LED | K: 4000 | CRI: 90 | BATTERY: NiCd

W	Real Lm. Emer.	Optics	H. Emer.	Permanent	Auto test	Code	220-240V		
12.2	129	18°	3	Yes	No	90-6679	- 14 - 60	- OE - DE	ON-OFF DALI
12.2	121	38°	3	Yes	No	90-6680			
12.2	115	47°	3	Yes	No	90-6681			

40x168 0-18 mm

Afrodita

Designed by LedsC4 Architectural



GU10 Ceiling
P. 868

Wall Fixture
P. 802

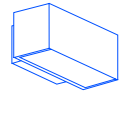
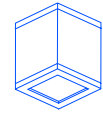

EMERGENCY LIGHTING

This wall light featuring modern, simple lines is designed for outdoor lighting. It can be used to highlight walkways or entrances from the wall.

Applique aux lignes modernes et simples conçue pour éclairer les espaces extérieurs. Elle peut servir à souligner les itinéraires ou les entrées depuis le mur.

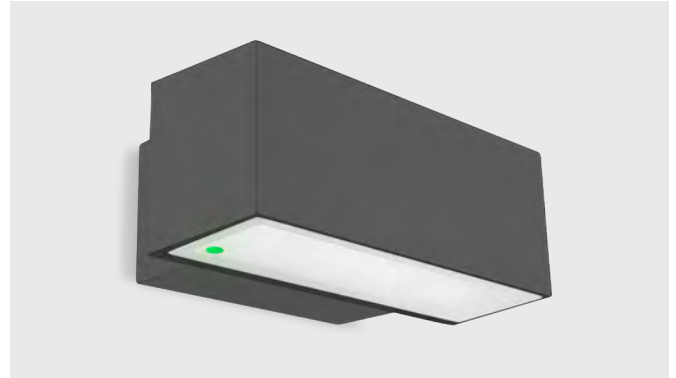

Afrodita

BODY MAT AL	DIF MAT GLA		50000h L80 B20	3 MacAdam	IP 66	IK 04	BREEAM	SEA SIDE SUITABLE		
----------------	----------------	--	-------------------	--------------	----------	----------	--------	----------------------	--	--

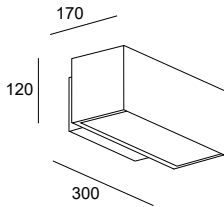

LED | W 20.8 | K: 3000 | Real Lm. 1670

W	Real Lm. Emer.	Optics	H. Emer.	Permanent	Auto test	Code	220-240V
20.8	557	88°	1	Yes	No	05-8764-Z5-OE	ON-OFF
20.8	557	88°	3	Yes	No	05-8765-Z5-OE	ON-OFF

Afrodita

BODY MAT AL	DIF MAT GLA		50000h L80 B20	3 MacAdam	IP 66	IK 04	BREEAM	SEA SIDE SUITABLE		
----------------	----------------	--	-------------------	--------------	----------	----------	--------	----------------------	--	--

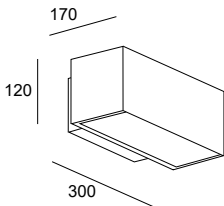

LED | W 20.8 | K: 4000 | Real Lm. 1837

W	Real Lm. Emer.	Optics	H. Emer.	Permanent	Auto test	Code	220-240V
20.8	612	88°	1	Yes	No	05-8766-Z5-OE	ON-OFF
20.8	612	88°	3	Yes	No	05-8767-Z5-OE	ON-OFF



Vol Ø135 mm

BODY MAT	DIF MAT		50000h	3	IP	IK			
AL	PMMA		L80 B20	MacAdam	54	08			

○
14

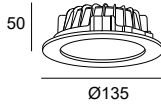

LED | K: 3000

W	Real Lm. Emer.	H. Emer.	Permanent	Auto test	Code	
11.9	299	3	Yes	No	90-4880-14-OE	220-240V ON-OFF

117 0-25 mm

Vol Ø135 mm

BODY MAT	DIF MAT		50000h	3	IP	IK			
AL	PMMA		L80 B20	MacAdam	54	08			

○
14

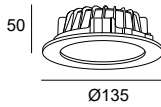

LED | K: 4000

W	Real Lm. Emer.	H. Emer.	Permanent	Auto test	Code	
11.9	299	3	Yes	No	90-4881-14-OE	220-240V ON-OFF

117 0-25 mm

Vol Ø205 mm

BODY MAT	DIF MAT		50000h	3	IP	IK			
AL	PMMA		L80 B20	MacAdam	54	08			

○
14

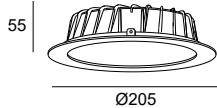

LED | K: 3000

W	Real Lm. Emer.	H. Emer.	Permanent	Auto test	Code	
19.5	350	3	Yes	Yes	90-2899-14-OE	220-240V ON-OFF

180 0-25 mm

Vol Ø205 mm

BODY MAT	DIF MAT		50000h	3	IP	IK			
AL	PMMA		L80 B20	MacAdam	54	08			

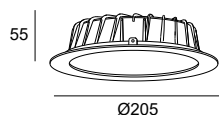
 ○
14

LED | K: 4000

W	Real Lm. Emer.	H. Emer.	Permanent	Auto test	Code	
19.5	350	3	Yes	Yes	90-4883-14-OE	220-240V ON-OFF

180 0-25 mm

Vol Ø254 mm

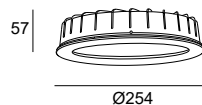
BODY MAT	DIF MAT		50000h	3	IP	IK			
AL	PMMA		L80 B20	MacAdam	54	08			

 ○
14

LED | K: 3000

W	Real Lm. Emer.	H. Emer.	Permanent	Auto test	Code	
30.2	299	3	Yes	No	90-4885-14-OE	220-240V ON-OFF

230 0-25 mm

Vol Ø254 mm

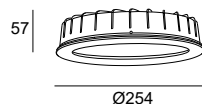
BODY MAT	DIF MAT		50000h	3	IP	IK			
AL	PMMA		L80 B20	MacAdam	54	08			

 ○
14

LED | K: 4000

W	Real Lm. Emer.	H. Emer.	Permanent	Auto test	Code	
30.2	299	3	Yes	No	90-4886-14-OE	220-240V ON-OFF

230 0-25 mm



This is a collection of downlights for spaces with diverse uses and purposes. It adapts to different recessing diameters, thereby facilitating installation on ceilings where there is already a gap.

Collection de downlights conçus pour des espaces à usages divers, qui s'adaptent à différents diamètres d'encastrement de manière à faciliter leur installation sur les plafonds dotés d'un orifice préexistant.



Veo Emergency 130mm

BODY MAT PC,AL	DIF MAT PC		50000h L80 B20	3 MacAdam	IP 54	LOW FLICKER		
-------------------	---------------	--	-------------------	--------------	----------	----------------	--	--

14



62



Ø110



Ø130

100 0-25 mm

LED | K: 3000 | CRI: 82

W	Real Lm.	Em	Optics	Permanent	Auto test	Code	220-240V
10	370	67		Yes	No	90-A032-14-03	ON-OFF
10	370	67		Yes	No	90-A032-14-D3	DALI-2

Veo Emergency 130mm

BODY MAT PC,AL	DIF MAT PC		50000h L80 B20	3 MacAdam	IP 54	LOW FLICKER		
-------------------	---------------	--	-------------------	--------------	----------	----------------	--	--

14



62



Ø110



Ø130

100 0-25 mm

LED | K: 4000 | CRI: 82

W	Real Lm.	Em	Optics	Permanent	Auto test	Code	220-240V
10	380	67		Yes	No	90-A033-14-03	ON-OFF
10	380	67		Yes	No	90-A033-14-D3	DALI-2

Veo Emergency 180mm

BODY MAT PC,AL	DIF MAT PC		50000h L80 B20	3 MacAdam	IP 54	UGR <22	LOW FLICKER		
-------------------	---------------	--	-------------------	--------------	----------	------------	----------------	--	--

14



80

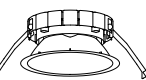

Ø161



Ø180

150-170 0-25 mm

LED | K: 3000 | CRI: 82

W	Real Lm.	Em	Optics	Permanent	Auto test	Code	220-240V
13.5	370	66		Yes	No	90-A034-14-03	ON-OFF
13.5	370	66		Yes	No	90-A034-14-D3	DALI-2



14

14

14

Veo Emergency 180mm

BODY MAT	DIF MAT		50000h	3	IP	UGR	LOW		
PC,AL	PC		L80 B20	MacAdam	54	<22	FLICKER		

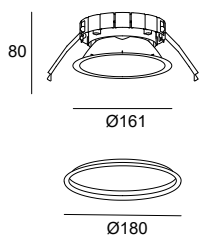

LED | K: 4000 | CRI: 82

W	Real Lm.	Em Optics	Permanent	Auto test	Code	
13.5	380	66	Yes	No	90-A035-14-03	220-240V ON-OFF
13.5	380	66	Yes	No	90-A035-14-D3	DALI-2

150-170 0-25 mm

Veo Emergency 230mm

BODY MAT	DIF MAT		50000h	3	IP	UGR	LOW		
PC,AL	PC		L80 B20	MacAdam	54	<19	FLICKER		

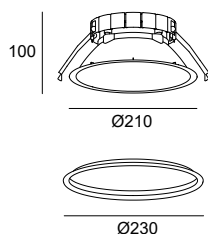

LED | K: 3000 | CRI: 82

W	Real Lm.	Em Optics	Permanent	Auto test	Code	
13.5	370	74	Yes	No	90-A036-14-03	220-240V ON-OFF
13.5	370	74	Yes	No	90-A036-14-D3	DALI-2

200-220 0-25 mm

Veo Emergency 230mm

BODY MAT	DIF MAT		50000h	3	IP	UGR	LOW		
PC,AL	PC		L80 B20	MacAdam	54	<19	FLICKER		

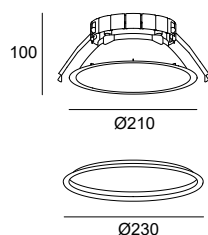

LED | K: 4000 | CRI: 82

W	Real Lm.	Em Optics	Permanent	Auto test	Code	
13.5	380	74	Yes	No	90-A037-14-03	220-240V ON-OFF
13.5	380	74	Yes	No	90-A037-14-D3	DALI-2

200-220 0-25 mm

Fixing accessories

Accessoires de fixation



Extra bezel to adapt to different diameters
Biseautage supplémentaire permettant de s'adapter aux différents diamètres

Included

Ecofit

Designed by LedsC4 Architectural

Downlight
P. 255

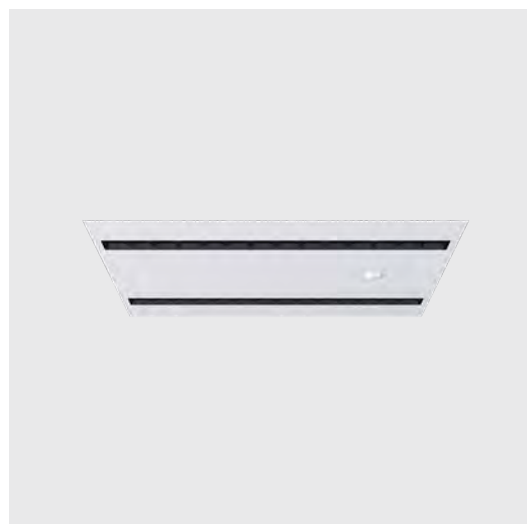
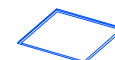

Workspaces are becoming more demanding, requiring comfortable and inclusive lighting that enhances people's well-being and health. Ecofit is a collection of highly efficient panels with two lens options to suit the diverse needs of the area being lit.

Les espaces de travail sont de plus en plus exigeants et nécessitent un éclairage confortable et inclusif, qui améliore le bien-être et la santé des personnes. Ecofit est une collection de panneaux très efficaces avec deux possibilités d'optiques pour s'adapter aux différents besoins de la zone à éclairer.

Ecofit Opticell Emergency

BODY MAT	50000h	3	IP	DIF MAT	UGR		
AL	L80 B20	MacAdam	40	PMMA	<19		





Code exemple / Exemple d'élaboration d'une référence: **AQ11-3PW8F30S14**

Model	Optics	W	K	CRI	Lm	Source	Finishes
AQ11 - Square / 595 × 595 	3PW8F3 Opticell	32.3	3000	80	4402	O3 ON-OFF 220-240V D3 DALI-2 220-240V	14
	3PW9F3 Opticell	32.3	3000	90	3962		
	3PX8F3 Opticell	32.3	4000	80	4596		
	3PX9F3 Opticell	32.3	4000	90	3962		
AQ12 - Square / 625 × 625 							
AQ13 - Rectangular / 1195 × 295 							
AQ14 - Rectangular / 1245 × 310 							



	Ecofit Opticell 595 × 595mm		Ecofit Plus 1195 × 295mm		Ecofit Plus 625 × 625mm 1245 × 310mm	
	OS	DS	O3	D3		

Required fixing accessories**Accessoires de fixation nécessaires**

	Emergency On-Off power supply Source d'alimentation Emergency On-Off	71-A223-14-00	-	71-A223-14-00	-	-
	Emergency On-Off power supply Source d'alimentation Emergency On-Off	-	71-A228-14-00	-	71-A228-14-00	-
	Surface installation kit Kit d'installation de surface	71-A329-14-00	71-A329-14-00	71-A331-14-00	71-A331-14-00	-
	Recessing kit for false ceiling Kit d'encastrement dans faux plafond	71-A330-14-00	71-A330-14-00	71-A724-14-00	71-A724-14-00	-
	Pendant installation kit Kit d'installation pour suspension	71-A332-00-00	71-A332-00-00	71-A333-00-00	71-A333-00-00	-

Emergency kits

Kits d'urgence

Conversion kits allow a luminaire to operate for a predetermined time as auxiliary lighting for emergency lighting.

Les Kits de conversion permettent de faire fonctionner un luminaire pendant une durée prédéterminée sous forme d'éclairage d'appoint à l'éclairage de secours.



Autotest

Si

DALI

Code

EM06-0001

Auto-test kit + DALI compatible for 1h and 3h
Kit autotest + DALI compatible pour 1 h et 3 h



IP	Class	Vin	Frecuency	Vout emergency mode	Iout emergency mode	h	Battery	Code
20	2	220-240V	50-60 Hz	10-48V	350-100mA	1h	Ni-Cd	EM06-0002
20	2	220-240V	50-60Hz	10-48V	200-60mA	3h	Ni-Cd	EM06-0003

Compatible with Compatible avec

Lighting modules with an input voltage range between 10 and 48V.

Modules d'éclairage avec une gamme de tension d'entrée entre 10 et 48 V.

Luminous flux in emergency mode 1h battery Flux lumineux en mode de secours sur batterie 1 h

Power	10W	15W	20W	25W	30W	40W	50W
%	60%	40%	30%	25%	20%	15%	10%

Luminous flux in emergency mode 3h battery Flux lumineux en mode de secours sur batterie 3 h

Power	10W	15W	20W	25W	30W	40W	50W
%	35%	24%	18%	14%	12%	9%	7%

*Values referenced to 36V. Consult sales team for other input voltage (Vin) configurations.

*Valeurs référencées à 36 V, consultez notre équipe commerciale pour d'autres configurations de tension d'entrée Vin.

Connectivity
solutions
Solutions
connectées

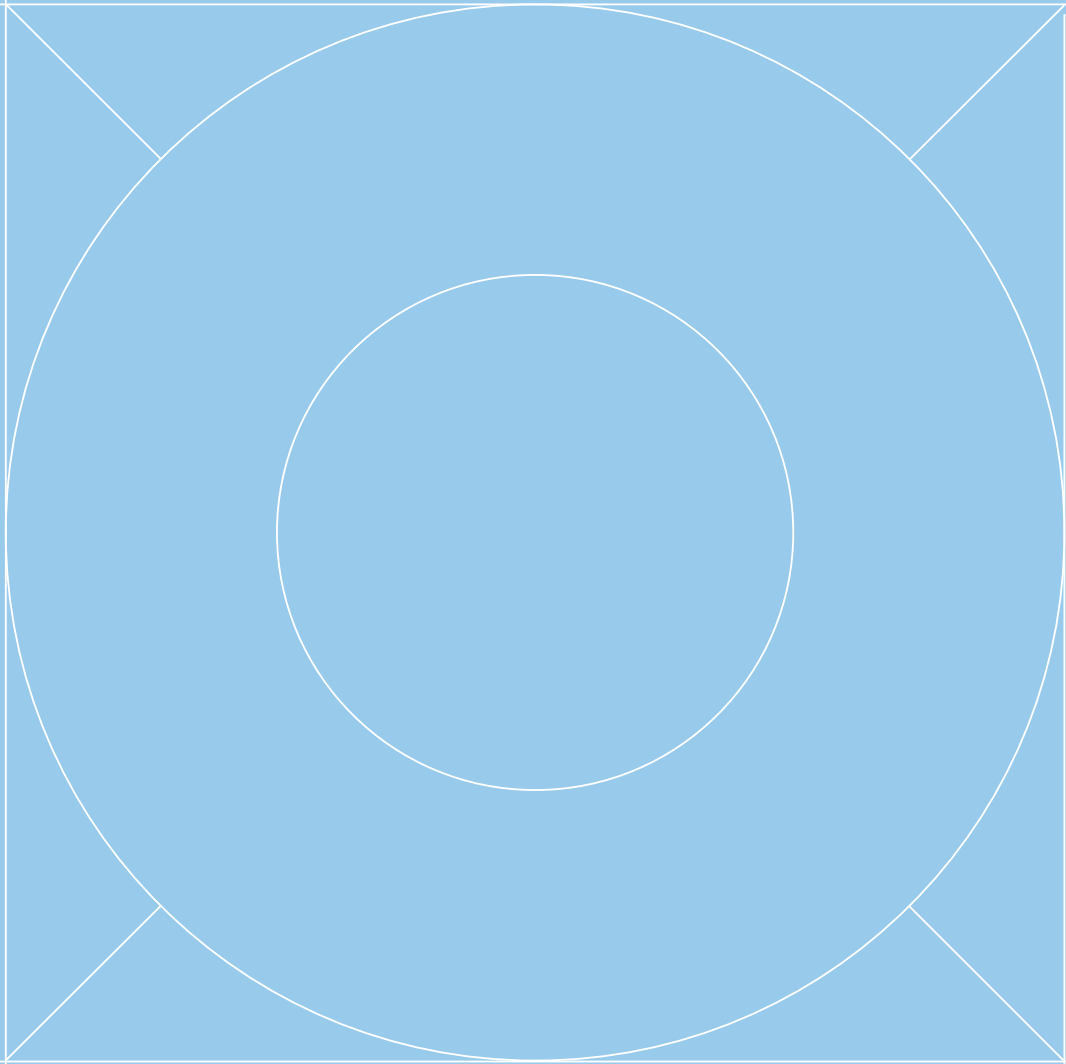

Solution for lighting control and connectivity in a space where resources must be used efficiently. Based on the D4i standard, it means any driver featuring this technology will be compatible with this platform. In addition to providing control functionalities, it allows the system to be monitored through the platform and, thus, gather data on occupancy and space use.

Solution pour le contrôle et la connectivité de l'éclairage dans un espace exigeant une utilisation efficace des ressources. Fondée sur la norme D4i, elle permet à tout driver muni de cette technologie d'être compatible avec cette plateforme. En plus d'offrir des fonctionnalités de contrôle, elle permet de surveiller le système par le biais de la plateforme et d'obtenir ainsi des données sur l'occupation et l'utilisation de l'espace.

Functionalities Fonctionnalités



- Wireless communication of luminaires with internet access
Communication sans fil des luminaires ayant accès à Internet
- Remote control Remote control
Commande à distance
- Installation status
État de l'installation
- Profile and group design
Définition des profils et des groupes



- Savings through natural light, occupancy and task adjustment
Économies selon la lumière naturelle, l'occupation et l'ajustement des tâches
- Energy reports adapted to the needs of each action carried out
Rapports énergétiques adaptés aux besoins de chaque action réalisée
- Real-time monitoring
Suivi en temps réel



- Information on ambient temperature and the luminaire to enable easy integration with air conditioning and heating systems
Informations sur la température ambiante et celle du luminaire pour une intégration facile avec les systèmes de climatisation et de chauffage



- Alarm management
Gestion des alarmes
- Programmable email notifications based on various parameters such as luminaire malfunction or overheating, available updates, etc.
Notifications par courriel programmables en fonction de divers paramètres tels que la défaillance ou la surchauffe d'un luminaire, les mises à jour disponibles, etc.



- Heat map reports for proper space management and assessment
Rapports de cartes thermiques pour une gestion correcte des espaces et leur évaluation

D4i devices Dispositifs D4i

		L x W x H mm	V in F (Hz)	Lum. max.	Protocol	Code
Controller Contrôleur						
	D4i platform controller-manager Gestionnaire de plateforme D4i Contrôleur	198 × 145 × 42	120-240V 50-60Hz	1500 Sensors	-	71-8063-00-00
Power supply Source d'alimentation						
	PoE power supply Source d'alimentation PoE (par câble Ethernet)	235 × 103 × 27	48V	-	PoE	71-8064-00-00
Gateway						
	Sensor Gateway Passerelle pour capteur	35 × 101,9 × 76,5	PoE	125 Sensors	IEEE 802.15.4	71-8061-00-00
Sensors Capteurs						
	Connective Multi-sensor Multicapteur connecté	27 × 18	D4i	4 Drivers	D4i	71-8056-00-00
	Multisensor Pro Multissensor Pro	27 × 18	D4i	4 Drivers	D4i	71-8057-00-00
	Connected black Track Multi-sensor Rail connecté multicapteur noir	120 × 40 × 35	220-240V 50-60Hz	4 Drivers	D4i	35-A075-60-00
	Connected white Track Multi-sensor Rail connecté multicapteur blanc	120 × 40 × 35	220-240V 50-60Hz	4 Drivers	D4i	35-A075-14-00
	Pro Connective Multi-sensor upgrade Mise à jour multicapteur connecté Pro	-	-	-	Software	71-8060-00-00
	Ceiling recessed accessory for D4i sensor Accessoire d'encastrement au plafond pour capteur D4i	20,7 × 13	-	-	-	71-8058-00-00
	Ceiling surface accessory for D4i sensor Accessoire de surface au plafond pour capteur D4i	25 × 35 × 67	-	-	-	71-8059-00-00
Switch panels Boîtiers de commande						
	Connective switch panel Boîtier de commande connecté	66,4 × 32,7 × 11,5	Battery CR2032	-	IEEE 802.15.4	71-8062-00-00

DALI2

Lighting control and connectivity solution based on the DALI2 standard (includes compatibility with DT8 drivers)

Solution de contrôle et de connectivité fondée sur la norme DALI2 (comprend la compatibilité avec les drivers DT8)

Functionalities Fonctionnalités

In one installation, major energy savings can be achieved through functionalities such as point-to-point management of luminaires, groups, scenes, constant light control, circadian cycle, occupancy control and hourly programmes, among other features. It enables you to calculate the hours of operation and consumption of each luminaire, thus enabling preventive maintenance.

Permet de réaliser de grandes économies d'énergie dans une installation, grâce à des fonctionnalités telles que la gestion point par point des luminaires, la gestion des groupes et des scènes, le contrôle de lumière constante, le rythme circadien, le contrôle selon l'occupation et les programmations horaires, entre autres.



CNTEC, Girona 2020.

Select the option that is best suited to your project
Choisissez l'option la mieux adaptée à votre projet

- ① Essential
- ② Performance
- ③ Advanced

①

— Calendar, groups, scenes, presence and brightness sensors
Calendrier, groupes, scènes, capteurs de présence et de luminosité

②

— Circadian cycle and Tunable White luminaires
Rythme circadien et luminaires Tunable White

— Compatible with emergency luminaire licence
Compatible avec licence pour luminaires de secours

③

— Compatible with BACnet licence
Compatible avec licence BACnet

— Linkable system up to 5 Advance controllers (can be viewed as 1 single controller)
Système pouvant relier jusqu'à 5 contrôleurs Advance (permet l'affichage comme un seul contrôleur)

DALI2 devices

Dispositifs DALI2

		L x W x H mm	IP	V in F (Hz)	Lums. max.	W max	Protocol	Code
Controllers Contrôleurs								
	DALI2 Essential	160 × 91 × 62	20	110-240 V 50-60 Hz	64 × 3 OUTPUT DALI2	DALI BUS OUTPUT 200 mA x3	DALI2	71-B102-00-00
	DALI2 Performance	160 × 91 × 62	20	110-240 V 50-60Hz	64 × 3 OUTPUT DALI2	DALI BUS OUTPUT 200 mA x3	DALI2	71-B103-00-00
	DALI2 Advance	160 × 91 × 62	20	110-240 V 50-60 Hz	64 × 3 OUTPUT DALI2	DALI BUS OUTPUT 200 mA x3	DALI2	71-B104-00-00
Power supplies Sources d'alimentation								
	1-channel DALI2 PWM 60 W at 24 V DALI2 PWM 1 canal 60 W à 24 V	150×53×35	67	100-305V 50-60Hz	-	60W 24V DC	PWM 1 ch	71-E098-00-00
	1-channel DALI2 PWM 120 W at 24 V DALI2 PWM 1 canal 120 W à 24 V	191×63×37,5	67	100-305V 50-60Hz	-	120W 24V DC	PWM 1 ch	71-E099-00-00
	2-channel DALI2 DT8 PWM / 160 W at 24 V DALI2 DT8 PWM 2 canaux / 160 W à 24 V	300×50×30	20	198-264V 50-60Hz	-	160W 24V DC	PWM 2 ch	71-B401-00-00
Dimmers Régulateurs								
	DALI actuator relay Relais actionneur DALI	92,5 × 62	20	220-240 V 50/60 Hz	-	2 mA / 6A	DALI2	71-B101-00-00
Sensors Capteurs								
	DALI2 sensor for recessing Capteur DALI2 encastré	46,7 Ø 58 × 65,4	20	DALI2 9,5-22,5 V	-	9 mA	DALI2	71-B098-00-00
	DALI2 sensor for surface Capteur DALI2 en saillie	96,3 Ø x 36,6	20	DALI2 9,5-22,5 V	-	9 mA	DALI2	71-B100-00-00
Switch panels Boîtiers de commande								
	4 digital signal converter Convertisseur 4 signaux numériques	7,7 × 28,2 × 14,6	20	DALI2 9,5-22,5 V	-	10 mA	DALI2	71-B099-00-00
	DALI 4-button black switch panel Boîtier de commande DALI à 4 boutons noir	80 × 80 × 26,6	20	DALI2 12-22,5 V	-	10 mA	DALI2	71-B756-60-60
	DALI 4-button white switch panel Boîtier de commande DALI à 4 boutons blanc	80 × 80 × 26,6	20	DALI2 12-22,5 V	-	10 mA	DALI2	71-B756-14-14
Licences Licences								
	BACnet 500 variable licence Licence BACnet 500 variables							71-B118-00-00
	Emergency Licence 100 luminaires Licence Urgence 100 luminaires							71-B117-00-00

Bluetooth Casambi

Lighting control solution using the Bluetooth Mesh protocol with direct control from a smartphone or tablet, with no additional components required. The system's ease of use makes it suitable for any user. Its application is ideal for flexible, dynamic settings where a high level of interaction with luminaires is required. Solution de contrôle d'éclairage fondée sur le protocole Bluetooth Mesh avec commande directe par smartphone ou tablette, sans nécessité d'ajouter aucun élément supplémentaire. La facilité d'utilisation du système le rend valable pour tout utilisateur. Son application est idéale pour les environnements flexibles et dynamiques, où une grande interaction avec les luminaires est nécessaire.



Brondesbury Park Synagogue, London 2022.

Functionalities Fonctionnalités



















- Individual luminaire control and point-to-point adjustment
Contrôle individuel des luminaires et réglage point par point
- Creation of luminaire groups
Création de groupes de luminaires
- Adjustment according to calendar
Réglage en fonction du calendrier
- Colour-temperature control
Contrôle de la température de couleur
- Circadian cycle
Rythme circadien
- Adjustment according to amount of natural light
Réglage selon le niveau de lumière naturelle

Bluetooth Casambi devices Dispositifs Bluetooth Casambi

		L x W x H mm	IP	V in F (Hz)	Lums. DALI	W max	Protocol	Code
Controllers Contrôleurs								
ON-OFF / PHASE CUT								
	On Off relay Relais On Off	50 × 120 × 32	40	100-240 50-60Hz	-	1500 W	On Off	71-A300-00-00
	0-10V – DALI dimmer Variateur 0-10 V – DALI	40 × 36 × 14	20	100-240V 50-60Hz	1	150W	Trailing edge	71-5959-00-00
DALI								
	0-10V – DALI dimmer Variateur 0-10 V – DALI	56 × 36 × 22	20	220-240V 50-60Hz	1	-	0-10 / DALI	71-5961-00-00
	2X0-10 V or 1xDALI dimmer Régulateur 2 x 0-10 V ou 1 x DALI	76 × 26 × 23	20	100-240V 50-60Hz	2- 0-10V 1- DALI	-	0-10V / DALI	71-B669-00-00
	DALI Broadcast dimmer Variateur DALI Broadcast	38 × 38 × 26	64	100-240V 50-60Hz	50	100mA DALI	DALI Dt8 Broadcast	71-A301-00-00
	DALI Broadcast dimmer 8 groups Variateur DALI Broadcast 8 groupes	180 × 42 × 25	20	24-48V DC	64	250mA Bus DALI	DALI 8 grupos	71-A239-00-00
	Track Low Voltage compatible DALI controller Variateur DALI compatible avec Track Low Voltage	143 × 18 × 59	20	24-48V DC	64	250mA Bus DALI	DALI Broadcast	71-8115-00-00
	White track DALI Broadcast dimmer Variateur DALI Broadcast sur rail blanc	91 × 45 × 124	20	100-240V 50-60Hz	64	250mA Bus DALI	DALI Broadcast	71-A243-14-14
	Black track DALI Broadcast dimmer Variateur DALI Broadcast sur rail noir	91 × 45 × 124	20	100-240V 50-60Hz	64	250mA Bus DALI	DALI Broadcast	71-A243-60-60
	Casambi DALI converter IP66 Convertisseur Casambi DALI IP66	108 × 62 × 108	66	100-240V 50-60Hz	64	150mA Bus DALI	DALI Broadcast	71-A237-00-00
PWM								
	1 ch PWM dimmer Variateur 1 canal PWM	45 × 58 × 25	20	100-240V 50-60Hz	-	-	-	71-A857-00-00
	4 ch PWM dimmer Variateur 4 canaux PWM	72,6 × 30 × 18	20	100-240V 50-60Hz	1	72W 12V DC, 144W 24V DC	PWM 4 canaux	71-8050-00-00
	4-channel PWM dimmer 240 W Régulateur 4 canaux PWM 240 W	87,2 × 53,2 × 25	20	12-24DC	1	120W 12V 240W 24V	PWM 4 ch	71-B672-00-00
	IP65 box power supply and 4-channel PWM dimmer Boîtier IP65 Source d'alimentation et variateur PWM 4 canaux	253 × 342 × 132	65	100-277V 50-60Hz	-	144W, 24V DC	PWM 4 ch	71-E300-00-00
DMX								
	Casambi DMX converter IP66 Convertisseur Casambi DMX IP66	108 × 62 × 10	66	100-240V 50-60Hz	-	-	DMX Broadcast	71-A238-00-00

Bluetooth Casambi devices

Dispositifs Bluetooth Casambi

		L x W x H mm	IP	V in F (Hz)	Lums. DALI	W max	Protocol	Code
Power supplies								
Sources d'alimentation								
	1-channel PWM 60 W at 24 V PWM 1 canal 60 W à 24 V	150 × 53 × 35	67	90-305V 50-60Hz	1	60W 24V	PWM 1 ch	71-B670-00-00
	1-channel PWM 120 W at 24 V PWM 1 canal 120 W à 24 V	191 × 63 × 37,5	67	90-305V 50-60Hz	1	120W 24V	PWM 1 ch	71-A242-00-00
	1-channel PWM 200 W at 24 V PWM 1 canal 200 W à 24 V	195 × 68 × 39,5	67	100-305V 50-60Hz	1	200W 24V	PWM 1 ch	71-B671-00-00
	Power supply 12W a 12V Source d'alimentation 12W a 12V	Ø 51 × 28	20	220-240V	-	-	-	71-B416-00-00
Sensores								
Capteurs								
	Recessed sensor Brightness and presence with DALI output Capteur d'encastrement Luminosité et présence avec sortie DALI	Ø 76 × 69	40	230V 50Hz	10	1500W, 20mA bus	DALI Broadcast	71-A696-00-00
	Presence and brightness sensor Détecteur de présence et de luminosité	Ø 85 × 88	20	220-240V 50Hz	-	-	-	71-8049-00-00
	Surface-to-ceiling accessory for sensor, 71-8049 Accessoire en saillie au plafond pour capteur 71-8049	65 × 82 × 95	-	-	-	-	-	71-B743-00-00
	Black three-phase track presence and brightness sensor Capteur de présence et de luminosité sur rail triphasé noir	70 × 59 × 39	IP20	220-240V 50Hz	-	-	-	71-A241-60-60
	White 3-phase track presence and brightness sensor Capteur de présence et de luminosité sur rail triphasé blanc	70 × 59 × 39	20	220-240V 50Hz	-	-	-	71-A241-14-14
Switch panels								
Boîtiers de commande								
	Black Casambi button panel Commande Casambi noire	90 × 90 × 12	20	Bateria CR2430	-	-	-	71-8053-00-00
	White Casambi button panel Commande Casambi blanche	90 × 90 × 12	20	Bateria CR2430	-	-	-	71-A240-00-00
	White Enoclean switch panel 1 button Boîtier de commande Enoclean 1 bouton blanche	80 × 86	20	-	-	-	-	71-B113-00-00
	Enoclean 1- or 2-button black switch panel Boîtier de commande Enoclean 1 ou 2 boutons noir	88 × 88 × 15	20	-	-	-	-	71-B673-00-00
	Enoclean 1- or 2-button white switch panel Boîtier de commande Enoclean 1 ou 2 boutons blanc	88 × 88 × 15	20	-	-	-	-	71-B674-00-00
	4 digital signal converter Convertisseur 4 signaux numériques	Ø 53 x 21	20	230V 50Hz	-	max.10 mA	Potential-free digital inputs Entrées numériques sans potentiel	71-A302-00-00
	DALI Casambi controller Contrôleur DALI Casambi	40 x 36 x 14	20	9,5-22,5V DC	-	DALI	-	71-8051-00-00
	Casambi timer for hourly programming Timer Casambi pour programmations horaires	45 × 58 × 25	20	45 × 12-48 × 25	-	-	-	71-8052-00-00

Functionalities Fonctionnalités



Puente de los Remedios, Villafranca de Cordoba 2022

Select the option that is best suited to your project
Choisissez l'option la mieux adaptée à votre projet

① Essential

② Performance

- RGB or RGBW DMX luminaire control
Contrôle des luminaires DMX RGB ou RGBW
- 1 DMX-RDM 512 universe
1 univers DMX-RDM 512
- Wifi
- 36 scenes
36 scènes
- Hourly programmes and calendar
Programmations horaires et calendaires
- Programming via app
Programmation via l'application
- 2 DMX-RDM 1024 universes
2 univers DMX-RDM 1024
- Up to 500 scenes
Jusqu'à 500 scènes
- Ethernet
- Remote access
Accès à distance







①

②

③

DMX Devices

Dispositifs DMX

		L x W x H mm	IP	V in F (Hz)	Lums. DMX	W max	Protocol	Code
Controllers Contrôleurs								
	DMX Essential Console Console DMX Essential	146 × 106 × 11	20	100-240V 50-60Hz	170 RGB 128 RGBW	DMX 512	512 Channels	71-B115-00-00
	DMX Performance Console Console DMX Performance	146 × 106 × 11	20	100-240V 50-60Hz	340 RGB 256 RGBW	DMX 512 (x2)	1024 Channels	71-B116-00-00
	DMX Advance controller Contrôleurr DMX Advancea	72 × 92 × 62	20	12 DC	512 RGB 384 RGBW	DMX 512 (x3) + RDM	1536 Channels	71-B667-00-00
Power supplies Sources d'alimentation								
	Power supply 12W to 12V Source d'alimentation 12 W à 12 V	Ø 51 × 28	20	220-240V	-	-		71-B416-00-00
Splitters								
	DMX 4 signal divider Diviseur 4 signaux DMX	72 × 92 × 62	20	12-24-48V DC	1	DMX 512 + RDM	4 output DMX	71-B125-00-00
	Repetidor 10 salidas DMX Repetidor 10 salidas DMX	217.5 × 112 × 44.5	20	100-240 V 50-60Hz	1	DMX 512 + RDM	10 outputs DMX RDM	71-B668-00-00
Dimmers Régulateurs								
	PWM RGBW DMX RDM regulation Régulateur PWM RGBW DMX RDM	140 × 50 × 26	20	12-48V 50-60Hz	1	12V 192W 48V 768W DMX 512 + RDM	4 Channels	71-B755-00-00

Standalone



Autonomous control solutions Can be used to control one or more luminaires within the same space autonomously. The Standalone solutions allow you to perform simple tasks and achieve large energy savings.
Solutions de contrôle autonomes. Elles peuvent servir à commander de manière autonome un ou plusieurs luminaires dans un même espace. Les solutions Standalone permettent d'exécuter des fonctions simples et d'obtenir de grandes économies d'énergie.

Institut Vilablareix, 2022





Thanks to built-in autonomous sensors, the lighting is regulated based on the presence of natural light, promoting energy savings.
Grâce à l'incorporation de capteurs autonomes, l'éclairage est régulé en fonction de l'apport de lumière naturelle, favorisant les économies d'énergie.







Sensors Capteurs

		L x W x H mm	IP	V in F (Hz)	mA	Lums. max.	W max	Protocol	Code
	Autonomous DALI multi-sensor Multicapteur DALI autonome	80 × 50	20	95-250V 50-60Hz	-	16	DALI BUS OUTPUT 35mA max	DALI	71-8067-00-00
	ON OFF movement sensor Détecteur de mouvement ON OFF	80 × 50	20	95-250V 50-60Hz	-	-	6A	ON OFF / RELE	71-B368-00-00
	Sensor de movimiento exterior IP44 Sensor de movimiento exterior IP44	103 × 78 × 80	44	110-240V 50-60Hz	-	-	200W	ON OFF / RELE	71-B754-00-00



Switch panels Boîtiers de commande

		L x W x H mm	RGB White	V in F (Hz)	Lums. máx.	W max	Protocol	Code
	DALI dimmer Variateur DALI	80 × 80 × 53	White	100-240V 50-60Hz	50	DALI BUS OUTPUT 100mA max	DALI	71-7671-00-00
	DALI iDALI DT8 TW switch panel Boîtier de commande DALI et DALI DT8 TW	71 × 71 × 50	DALI (White) DALI Dt8 (TW)	220-240V 50-60Hz	25	2W 52mA	DALI2	71-B361-00-00
	DMX controllers Contrôleurs DMX	86 × 86 × 42	RGB	100-240V 50-60Hz	-	-	DMX	71-7666-00-00
	PWM controllers Contrôleurs PWM	86 × 86 × 32	RGB	12-24	-	240W @ 12V 480W @ 24V	PWM	71-7664-00-00

RF remotes and dimmers**Commandes et variateurs RF**

		L x W x H mm	RGB White	V in F (Hz)	Lums. max.	W max	Protocol	Code
	White controller Contrôleur blanc	140 × 48 × 17	White	Battery 3xAAA	869,5 / 916,5 / 434 MHz	-	RF	71-7670-00-00
	White receiving controller Contrôleur blanc récepteur	95 × 37 × 20	White	12-36	869,5 / 916,5 / 434 MHz	96W @ 12V 192W @ 24V	PWM	71-7668-00-00
	RGB controller Contrôleur RGB	140 × 48 × 17	RGB	Battery 3xAAA	869,5 / 916,5 / 434 MHz	-	RF	71-7667-00-00
	RGB receiving controller Contrôleur RGB récepteur	178 × 46 × 22	RGB	12-48	869,5 / 916,5 / 434 MHz	240W @ 12V 480W @ 24V	PWM	71-7669-00-00

Standalone**Ready to**

		L x W x H mm	V in F (Hz)	mA	Lums. max.	W max	Protocol	Code
	D4i autonomous presence and brightness sensor Capteur de présence et de luminosité autonome D4i	Ø 22 (cut) Ø 30 × 43,5	12-22,5 V DC		4		D4i / Bluetooth	71-A723-00-00
	DALI controllers Contrôleurs DALI	86 × 86 × 42	White	100-240 50-60Hz	50	DALI BUS OUTPUT 100mA max	DALI	71-7665-00-00

Request your switch panel or sensor with the light scenes you need.

Commandez votre boîtier ou capteur avec les scènes lumineuses dont vous avez besoin.

Electrical Units & Accessories

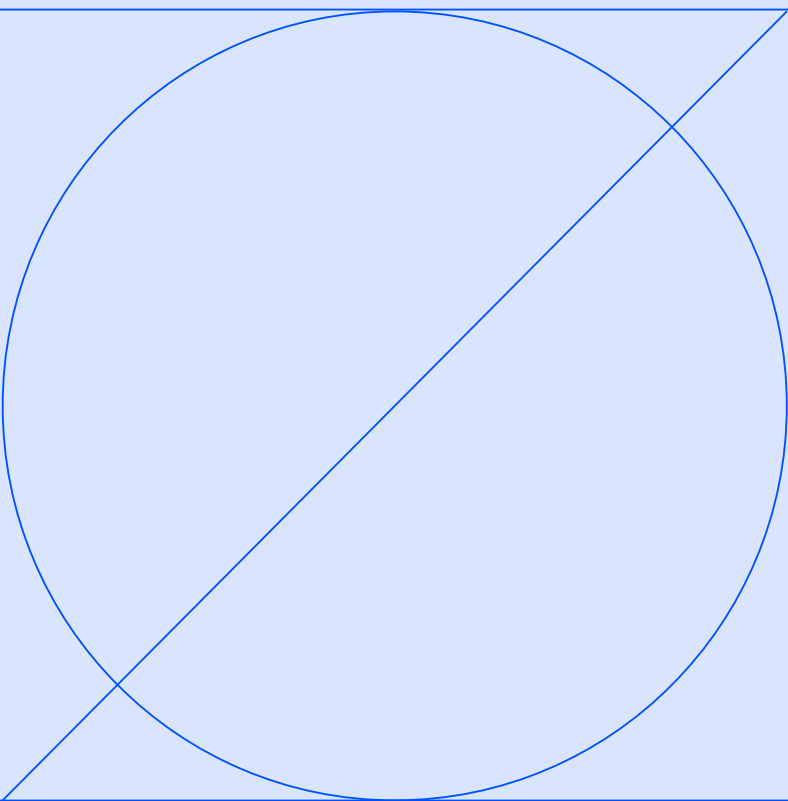

Installation recommendations

Conseils d'installation

Products with a remote driver

Install the driver within 2 metres of the product when the EMC levels for each application cannot be checked, in accordance with reference standards. The polarity of the product's cables must be checked before they are connected to the driver's secondary side, given that the incorrect polarity may damage the LED module and/or driver.

Control

Control signal cables must be installed separately from power cables. Switches are not permitted on the driver's secondary side.

Phase-cut control

- Basic phase-cut control. Does not require additional cables.
- Products with an L-control driver: they enable control with TRIAC/IGBT dimmers; leading-edge/forward-phase control.
- Products with a C-control driver: they enable control with IGBT dimmers; trailing-edge/reverse-phase control.
- Products with LC-control driver: they allow both aforementioned types of dimmers.
- Check dimmer-driver compatibility.

Push control

Requires an additional cable. NO (Normally Open) push buttons should be used. A quick press switches the product on or off. If the button is pressed and held, the brightness level is adjusted.

0/1-10V control

Analogue control that requires two additional polarised cables. A dimmer generates a constant voltage signal between 0 and 10V. If a voltage of 1V is applied, the driver will adjust the product's brightness to the minimum, however, when a voltage of 10V is applied, the product's brightness will be set to its maximum. The drivers that allow a control signal between 0-10V are capable of switching off the product completely when they receive a signal of 0V from the dimmer.

DALI/DALI-2 control

Digital control protocol developed by leading driver manufacturers to create a control standard in the lighting industry. It allows scenes to be memorised, messages to be sent in the event of a breakdown or the end of the product's life, point-to-point product control and planning, and emergency management. It requires two additional non-polarised cables. A cable with a cross-section of 1.5mm² is recommended. DALI-2 certification improves interoperability between DALI devices.

DMX control

Digital control protocol used in the world of show lighting. It requires two additional polarised cables. Using a twisted, shielded cable with an impedance of 120Ω is recommended.

Casambi control

Bluetooth Mesh control system

We recommend not to exceed 15m distance between devices, nor to use metal enclosures that may affect wireless communication.

Produits à driver distant

Il est recommandé d'installer le driver à un maximum de 2 mètres du produit lorsqu'il n'est pas possible de vérifier les niveaux de compatibilité électromagnétique (CEM) de chaque application, conformément aux normes de référence. Il est nécessaire de vérifier la polarité des câbles du produit avant de les relier au secondaire du driver, car une mauvaise connexion risque d'endommager le module LED et/ou le driver.

Variation

Les câbles de signal de variation doivent être installés séparément des câbles d'alimentation. Il n'est pas permis d'installer des interrupteurs sur le secondaire du driver.

Réglage par ligne (coupure de phase)

- Réglage de base par ligne : n'exige pas de câbles supplémentaires.
- Produits munis d'un driver de variation de type « L » : admettent le réglage avec des dimmers de type TRIAC/IGBT ; réglage par début de phase (leading edge/forward phase control).
- Produits munis d'un driver de variation de type « C » : admettent le réglage avec des dimmers de type IGBT ; réglage par fin de phase (trailing edge/reverse phase control).
- Produits munis d'un driver de type « LC » : admettent les deux types de dimmers susmentionnés.
- Il est conseillé de vérifier la compatibilité dimmer-driver.

Réglage Push

Exige un câble supplémentaire. Il convient d'utiliser des boutons poussoirs NO (normalement ouverts). Il suffit d'appuyer rapidement dessus pour allumer ou éteindre le produit. Maintenir le bouton poussoir enfoncé permet de régler le niveau de luminosité.

Réglage 0/1-10 V

Réglage analogue qui exige deux câbles supplémentaires à polarité. Un dimmer génère un signal à tension constante de 0 à 10 V. Appliquer une tension de 1 V permet de régler la luminosité du produit au minimum, tandis qu'en appliquant une tension de 10 V, le produit brillera au maximum. Les drivers prenant en charge un signal de réglage doté d'une plage comprise entre 0 et 10 V sont capables d'éteindre complètement le produit lorsqu'ils reçoivent 0 V du dimmer.

Contrôle DALI/DALI-2

Protocole de contrôle numérique mis au point par les principaux fabricants de drivers pour créer une norme de réglage dans le secteur de l'éclairage. Il permet la mémorisation de scènes, l'envoi de messages en cas de panne ou en fin de vie du produit, le contrôle et la planification point par point du produit, ainsi que la gestion des situations d'urgence. Exige deux câbles supplémentaires sans polarité. Il est conseillé d'utiliser un câble de section de 1,5 mm². La certification DALI-2 améliore l'interopérabilité entre dispositifs DALI.

Contrôle DMX

Protocole de contrôle numérique utilisé dans le domaine de l'éclairage de spectacles. Exige deux câbles supplémentaires avec polarité. Il est conseillé d'utiliser un câble torsadé, blindé et doté d'une impédance de 120 Ω.

Contrôle Casambi

Système de contrôle Bluetooth Mesh

Il est recommandé de ne pas dépasser une distance de 15 m entre les dispositifs, ni d'utiliser de boîtiers métalliques qui affectent la communication sans fil.



BUILT-IN FLOOR LUMINAIRES - DRAINAGE

It is essential to follow the assembling instructions and the installation guide of the built-in luminaires in order to achieve the best performance.



1. Avoid installing the luminaires in terrain depressions.
2. Avoid installing the luminaires in areas where water can accumulate and in places that are permanently damp, such as gardens or lawns.
3. Avoid the use of chemical products used to fertilise gardens because they could damage some of the components.
4. Level the luminaire with the surface.
5. Anticipate a dilation coating for built-in luminaires installed on surfaces like cement or concrete, to avoid possible dilation or compression.
6. Install an effective drainage system to avoid the accumulation of water, at least 25 cm of gravel under the installation casing. A correct drainage must absorb up to 10 litres of water in 15 minutes.
7. Put the light on for 20 minutes without the glass to avoid condensation inside.

ENCASTRABLES AU SOL – DRAINAGE

Il est indispensable de suivre les instructions et le guide d'installation des encastrables afin de garantir un éclairage optimum.









































1. Eviter l'installation de luminaires dans des zones de dépression de terrain.
2. Eviter l'installation de luminaires dans des espaces où s'accumule de l'eau ou des zones humides telles que jardins ou pelouses.
3. Eviter l'utilisation de produits chimiques utilisés pour le compostage des jardins car ils peuvent détériorer certains composants.
4. Nivelier le terrain en vue de l'installation des luminaires.
5. Prévoir un recouvrement pour la dilatation dans le cas de luminaires encastrables installés en surface tel que le ciment ou le béton, afin d'éviter une possible dilatation ou compression.
6. Poser un drain efficace afin d'éviter toute stagnation de l'eau, avec un minimum de 25 centimètres de gravier en dessous de l'installation. Un drain efficace doit permettre d'absorber jusqu'à 10 litres d'eau en 15 minutes.
7. Faire fonctionner le luminaire pendant 20 minutes, sans le verre, afin d'éviter toute condensation d'eau à l'intérieur.

Smart accessories / Accessoires Smart

		Tc	P (W)	Lm	V	Hz	Protocol	Optics	Code
	Bulb E27 RGBW Wifi	RGBW	12	950*	220-240V	50Hz	Light for Life	180°	71-8219-00-00
	Bulb GU10 TW Wifi	TW	5	345*	220-240V	50Hz	Light for Life	180°	71-8220-00-00
	Bulb E14 TW Wifi	TW	5	470*	220-240V	50Hz	Light for Life	200°	71-8221-00-00

Drivers



L x W x H mm	IP	CLASS	V in	Frequency Fréquence	V out	Constant current Iout (mA)	Maximum power (W) Puissance maximale (W)	Protocol	
124x79x22	20		110-240V	50-60Hz	0-74V	350-1050	50	ON-OFF	71-3542-00-00
124x79x22	20		110-240V	50-60Hz	2-74V	350-1050	60	PUSH;0-10V;1-10V;DALI2	71-4706-00-00
166x47x35	20		220-240V	50-60Hz	2-47V	350-750	32	PHASE-CUT 230V-PUSH	71-4898-00-00
129x76x30	20		99-264V	50-60Hz	48V	1050-2100	55	ON-OFF	71-4914-00-00
110,4x52x22	20		110-240V	50-60Hz	2-43V	250-700	20	DALI2	71-6192-00-00
123x45x19	20		100-240V	50-60Hz	23-46V	350	16,1	ON-OFF	71-6652-00-00
105x68x32	20		100-240V	50-60Hz	21-43V	700	30,1	ON-OFF	71-6653-00-00
115x29x45	20		100-240V	50-60Hz	10-29V	700	20,3	ON-OFF	71-6658-00-00
102x38x21	20		220-240V	50-60Hz	6-14V	700	10	PHASE-CUT 230V	71-7663-00-00
158x22x19	20		100-240V		2-40V	350	15	ON-OFF	71-7699-00-00
50x40x22	20		90-264V	50-60Hz	2-8,5V	700	6	ON-OFF	71-7713-00-00
150x43x25	20		100-240V	50-60Hz	5-13V	700	9	DALI2;PUSH	71-A190-00-00
150x43x25	20		100-240V	50-60Hz	23-46V	350	16	DALI2;PUSH	71-A191-00-00
152x46x36	20		100-240V	50-60Hz	10-43V	350-700	30	DALI2;PUSH	71-A192-00-00
146,5x44x30	20		220-240V	50-60Hz	10-38V	350-1050	38	CASAMBI	71-A260-00-00
146,5x44x30	20		220-240V	50-60Hz	8-32V	650-1400	45	CASAMBI	71-A261-00-00
101,5x49x29	20		220-240V	50-60Hz	27-42V	350	14	PHASE-CUT 230V	71-A297-00-00
145x51x29,5	20		220-240V	50-60Hz	17-39V	700	25	PHASE-CUT 230V	71-A299-00-00
146x44x30	20		220-240V	50-60Hz	10-54V	300-1050	38	DALI2;PUSH	71-A303-00-00
66,3x38,5x21,8	20		100-240V	50-60Hz	8,6-18V	350	6	ON-OFF	71-A652-00-00
123x45x19	20		100-240V	50-60Hz	5-13V	700	9	ON-OFF	71-B232-00-00
158x22x19	20		90-264V	50-60Hz	2-27V	500	14	ON-OFF	71-B406-00-00
97,3x41x22	20		110-277V	50-60Hz	8-40V	150-500	20	DALI2	71-B407-00-00
145x40x30	42		220-240V		32-54V	700	37,8W	PHASE CUT 240V	71-B666-00-00
76x22x20	20		220-240V		2,5-12V	350	3	ON-OFF	71-B681-00-00
76x22x20	20		220-240V		2,5-4,5V	700	3	ON-OFF	71-B682-00-00
47,5x27,2x20	20		220-240V		2,7-4,5V	700	3	ON-OFF	71-B781-00-00
165x45x37	68		100-240V	50-60Hz	6-14,5V	700	10	ON-OFF	71-E014-00-00
165x45x37	67		100-240V	50-60Hz	15-29V	700	20	ON-OFF	71-E015-00-00
121,5x53,5x26	68		99-264V	50-60Hz	2-49V	350	17	ON-OFF	71-E079-00-00
121,5x53,5x26	68		99-264V	50-60Hz	2-49V	700	30	DALI2	71-E080-00-00
135x80x31	68		99-264V	50-60Hz	10-50V	350	17,5	0-10V;1-10V;DALI2	71-E083-00-00
135x80x31	68		99-264V	50-60Hz	10-50V	500	25	DALI2	71-E085-00-00
135x80x31	68		99-264V	50-60Hz	10-50V	700mA	70	0-10V;1-10V;DALI2	71-E086-00-00
135x80x31	68		99-264V	50-60Hz	10-50V	1400mA	70	0-10V;1-10V;DALI2	71-E216-00-00
130x38x28	20		110-240V	50-60Hz	2-14V	1400	18	ON-OFF	71-E217-00-00
115x34x19	20		90-264V	50-60Hz	1-41,5V	60-360	15	ON-OFF	71-E218-00-00
300x47x47	67		100-240V	50-60Hz	2-4V	1200	4,8	ON-OFF	71-E225-05-05
300x47x47	67		100-240V	50-60Hz	6-14,5V	700	10	ON-OFF	71-E226-05-05
135x80x31	68		99-264V	50-60Hz	10-50V	1200mA	60	0-10V;1-10V;DALI2	71-E518-00-00

Sensors / Capteurs

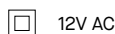

L x W x H mm	V in F (Hz)	Luminaires Luminaires max.	Protocol		Code
120 x 40 x 35	220-240V 50-60Hz	4 Drivers	D4i	White Sensor D4i Connected to Track	35-A075-14-00
120 x 40 x 35	220-240V 50-60Hz	4 Drivers	D4i	Black Sensor D4i Connected to Track	35-A075-60-00

Power supply / Source d'alimentation



L x W x H mm	IP	CLASS	V in	Frequency Fréquence	Constant voltage Vdc (V)	Maximum power (W) Puissance maximale (W)	Protocol	
219×63×35,5	67		100-305V	47-63Hz	48	150	ON-OFF	71-7646-00-00
244×71×37,5	67		100-305V	47-63Hz	48	240	ON-OFF	71-7647-00-00
191×63×38	67		90-305V	47-63Hz	24	120	CASAMBI;PWM	71-A242-00-00
180×52×30	20		220-240V	-	48	75	ON-OFF	71-A258-00-00
300×40×30	20		220-240V	-	48	120	ON-OFF	71-A259-00-00
252×90×44	67		90-305V	47-63Hz	48	320	ON-OFF	71-B077-00-00
262×43×125	67		90-305V	47-63Hz	48	480	ON-OFF	71-B078-00-00
280×144×49	67		90-305V	-	48	620	ON-OFF	71-B079-00-00
300×50×35	20		198-264V	-	24	160	DALI DT8	71-B401-00-00
51×49×27	20		220-240V	-	12	20	ON-OFF	71-B416-00-00
300×30×16	20		220-240V	-	24	30	ON-OFF	71-B640-00-00
350×30×18	20		220-240V	-	24	100	ON-OFF	71-B641-00-00
350×30×18	20		220-240V	-	24	150	ON-OFF	71-B642-00-00
400×40×22	20		220-240V	-	24	250	ON-OFF	71-B643-00-00
250×30×21	67		220-240V	-	24	30	ON-OFF	71-B644-00-00
290×30×21	67		220-240V	-	24	60	ON-OFF	71-B645-00-00
320×30×21	67		220-240V	-	24	100	ON-OFF	71-B646-00-00
350×30×21	67		220-240V	-	24	160	ON-OFF	71-B647-00-00
400×30×21	67		220-240V	-	24	240	ON-OFF	71-B648-00-00
400×60×22	67		220-240V	-	24	400	ON-OFF	71-B649-00-00
146×55×19	20		100-240V	-	24	20	ON-OFF	71-B650-00-00
148×40×32	67		90-305V	-	24	16	ON-OFF	71-B651-00-00
300×30×16	20		220-240V	-	24	60	DALI2	71-B652-00-00
350×30×16	20		220-240V	-	24	150	DALI2	71-B653-00-00
400×40×22	20		220-240V	-	24	250	DALI2	71-B654-00-00
290×30×21	67		220-240V	-	24	60	DALI2	71-B655-00-00
350×30×21	67		220-240V	-	24	160	DALI2	71-B656-00-00
400×60×22	67		220-240V	-	24	400	DALI2	71-B657-00-00
350×30×18	20		220-240V	-	48	150	ON-OFF	71-B658-00-00
350×30×18	20		220-240V	-	48	250	ON-OFF	71-B659-00-00
320×30×21	67		220-240V	-	48	100	ON-OFF	71-B660-00-00
350×30×21	67		220-240V	-	48	160	ON-OFF	71-B661-00-00
400×30×21	67		220-240V	-	48	240	ON-OFF	71-B662-00-00
290×30×21	67		220-240V	-	48	60	DALI2	71-B663-00-00
320×30×21	67		220-240V	-	48	100	DALI2	71-B664-00-00
400×30×21	67		220-240V	-	48	250	DALI2	71-B665-00-00
400×30×21	67		220-240V	-	24	240	DALI2	71-B675-00-00
188×50×33,5	67		90-305V	-	12	96	ON-OFF	71-B676-00-00
146×55×19	20		100-240V	-	12	20	ON-OFF	71-B677-00-00
400×60×22	67		220-240V	-	48	400	ON-OFF	71-B678-00-00
205×42×10	67		100-240V	50-60Hz	24	20	ON-OFF	71-E101-05-05

Device controllers / Contrôleur gradation









IP20

L x W x H mm	IP	CLASS	V in	Frequency Fréquence	Maximum power (W) Puissance maximale (W)	Protocol	
153x65x20	20		12-24V 85-240V		4CHx48W	DMX	71-3493-00-00
40,4×36,3×14	20		220-240V 12-24V	50-60Hz	Max.150W (230V)	CASAMBI-RLC	71-5959-00-00
56,5×35,8×22,3	20		24-48V 220-240V	50-60Hz	Max. 1 driver	CASAMBI- DALI/O-10V	71-5961-00-00
30×72,6×18	66		100-240V 100-240V		Max.144W	CASAMBI- PWM	71-8050-00-00
143×18×59	20		100-240V 47-63Hz		Max. 64 devices	CASAMBI-DALI	71-8115-00-00
108×108×62	67		90-305V 47-63Hz	50-60Hz	Max. 64 devices	CASAMBI-DALI	71-A237-00-00
108×108×62	67		90-305V 47-63Hz	50-60Hz	Max. 32 devices	CASAMBI-DMX	71-A238-00-00
91×45×124	67		90-305V 47-63Hz	50-60Hz	Max. 64 devices	CASAMBI	71-A243-14-14
91×45×124	67		90-305V 47-63Hz	50-60Hz	Max. 64 devices	CASAMBI	71-A243-60-60

Power supply and controller selection table
Tableau de sélection des sources d'alimentation et des contrôleurs





Non dimmable power supply Source d'alimentation non dimmable																	Dimmable controllers and power supplies Sources et contrôleurs dimmables							
																	1-10V	DALI-2	DALI-2	DALI-2	DALI-2			
Reference Référence	71-B650	71-B651	71-B640	71-B641	71-B642	71-B643	71-B644	71-B645	71-B646	71-B647	71-B648	71-B649	71-0727	71-B652	71-B653	71-B654	71-B655							
Power supply voltage Tension d'alimentation	-	-	-	-	-	-	-	-	-	-	-	-	12/ 24VDC	-	-	-	-							
Output voltage Tension de sortie	24VDC												12/ 24VDC	24VDC	24VDC	24VDC	24VDC							
P (W)	20	16	30	100	150	250	30	60	100	160	240	400	2×6.5A	60	150	250	60							
IP	20	67	20	20	20	20	67	67	67	67	67	67	20	20	20	20	67							
PAG.	985	985	985	985	985	985	985	985	985	985	985	985	985	985	985	985	985							
Reference Référence	Name Nom	T Kelvin	P (W)	Vdc	L(m)	W/m	Maximum number of metres which can be fed by each power supply Nombre maximum de mètres de bandeau pouvant être alimentés par chaque dispositif											Maximum number of metres which can be fed by each power supply Nombre maximum de mètres de bandeau pouvant être alimentés par chaque dispositif						
91-7908	BASIC 4,8	2700	24	24	5	4,8	3	3	5	19	29	49	5	11	19	31	47	79	61	11	29	49	11	
91-7909		3000	24	24	5	4,8	3	3	5	19	29	49	5	11	19	31	47	79	61	11	29	49	11	
91-7910		4000	24	24	5	4,8	3	3	5	19	29	49	5	11	19	31	47	79	61	11	29	49	11	
91-7911		6000	24	24	5	4,8	3	3	5	19	29	49	5	11	19	31	47	79	61	11	29	49	11	
91-7912		2700	24	24	5	4,8	3	3	5	19	29	49	5	11	19	31	47	79	61	11	29	49	11	
91-7913		3000	24	24	5	4,8	3	3	5	19	29	49	5	11	19	31	47	79	61	11	29	49	11	
91-7914		4000	24	24	5	4,8	3	3	5	19	29	49	5	11	19	31	47	79	61	11	29	49	11	
91-7915		6000	24	24	5	4,8	3	3	5	19	29	49	5	11	19	31	47	79	61	11	29	49	11	
91-A012		RGB	24	24	5	4,8	3	3	5	19	29	49	5	11	19	31	47	79	-	-	-	-	-	
91-3282	BASIC 9,6	2500	48	24	5	9,6	1	1	2	9	14	24	2	5	9	15	23	39	30	5	14	24	5	
91-7916		2700	48	24	5	9,6	1	1	2	9	14	24	2	5	9	15	23	39	30	5	14	24	5	
91-7917		3000	48	24	5	9,6	1	1	2	9	14	24	2	5	9	15	23	39	30	5	14	24	5	
91-7918		4000	48	24	5	9,6	1	1	2	9	14	24	2	5	9	15	23	39	30	5	14	24	5	
91-7919		6000	48	24	5	9,6	1	1	2	9	14	24	2	5	9	15	23	39	30	5	14	24	5	
91-7920		RGB	48	24	5	9,6	1	1	2	9	14	24	2	5	9	15	23	39	-	-	-	-	-	
91-7921		2700	48	24	5	9,6	1	1	2	9	14	24	2	5	9	15	23	39	30	5	14	24	5	
91-7922		3000	48	24	5	9,6	1	1	2	9	14	24	2	5	9	15	23	39	30	5	14	24	5	
91-7923		4000	48	24	5	9,6	1	1	2	9	14	24	2	5	9	15	23	39	30	5	14	24	5	
91-7924		6000	48	24	5	9,6	1	1	2	9	14	24	2	5	9	15	23	39	30	5	14	24	5	
91-7925		RGB	48	24	5	9,6	1	1	2	9	14	24	2	5	9	15	23	39	30	5	14	24	5	
91-7926		BASIC 14,4	2700	72	24	5	14,4	1	1	1	6	9	16	1	3	6	10	15	26	20	3	9	16	3
91-7927			3000	72	24	5	14,4	1	1	1	6	9	16	1	3	6	10	15	26	20	3	9	16	3
90-A013	3000		72	24	5	14,4	1	1	1	6	9	16	1	3	6	10	15	26	20	3	9	16	3	
91-2379	RGB	72	24	5	14,4	1	1	1	6	9	16	1	3	6	10	15	26	-	-	-	-	-		
91-7928	BASIC 19,2	2700	96	24	5	19,2	-	-	1	4	7	12	1	2	4	7	11	19	15	2	7	12	2	
91-A016		2700	96	24	5	19,2	-	-	1	4	7	12	1	2	4	7	11	19	15	2	7	12	2	
91-7929		3000	96	24	5	19,2	-	-	1	4	7	12	1	2	4	7	11	19	15	2	7	12	2	
91-5567		3000	96	24	5	19,2	-	-	1	4	7	12	1	2	4	7	11	19	15	2	7	12	2	
91-A014		4000	96	24	5	19,2	-	-	1	4	7	12	1	2	4	7	11	19	15	2	7	12	2	
91-A015		6000	96	24	5	19,2	-	-	1	4	7	12	1	2	4	7	11	19	15	2	7	12	2	
91-5571		BASIC 28,8	2700	144	24	5	28,8	-	-	-	3	4	8	-	1	3	5	7	13	10	1	4	8	1
91-5572	3000		144	24	5	28,8	-	-	-	3	4	8	-	1	3	5	7	13	10	1	4	8	1	
91-5573	4000		144	24	5	28,8	-	-	-	3	4	8	-	1	3	5	7	13	10	1	4	8	1	

Dimmable controllers and power supplies Sources et contrôleurs dimmables					RF receivers with remote control Récepteurs RF avec télécommande				Wall front Façade murale
DALI-2	DALI-2	DMX 4xCH	 Bluetooth	 Bluetooth	RF Receiver 1 channel	RF Receiver 4 channel	RGB	White	PWM/RGBW
71-B656	71-B657	71-B755	71-8050	71-A242					
-	-	12/ 24VDC	12/24VDC	90-305VAC	71-7668	71-7669	71-7667	71-7670	71-7664
24VDC	24VDC	12/ 24VDC	12/24VDC	24VDC	12/24 Vdc	12/24 Vdc	-	-	12/24VDC
160	400	4x2A	6A	120	12/24 VDC	12/24 VDC	-	-	12/24VDC
67	67	20	20	67	96/192	4x5A	-	-	4x5A
985	985	985	985	985	20	20	-	-	20
Maximum number of metres which can be fed by each power supply Nombre maximum de mètres de bandeau pouvant être alimentés par chaque dispositif					Maximum number of metres which can be fed by each power supply Nombre maximum de mètres de bandeau pouvant être alimentés par chaque dispositif				Maximum number of metres which can be fed by each power supply Nombre maximum de mètres de bandeau pouvant être alimentés par chaque dispositif
31	79	-	-	23	985	985	985	985	985
31	79	-	-	23	38	-	-	-	-
31	79	-	-	23	38	-	-	-	-
31	79	-	-	23	38	-	-	-	-
31	79	-	-	23	38	-	-	-	-
31	79	-	-	23	38	-	-	-	-
31	79	-	-	23	38	-	-	-	-
31	79	-	-	23	38	-	-	-	-
31	79	-	-	23	38	-	-	-	-
-	-	28	28	-	-	71	-	-	71
15	39	-	-	11	19	-	-	-	-
15	39	-	-	12	19	-	-	-	-
15	39	-	-	12	19	-	-	-	-
15	39	-	-	12	19	-	-	-	-
15	39	-	-	12	19	-	-	-	-
-	-	14	14	-	-	35	-	-	35
15	39	-	-	12	19	-	-	-	-
15	39	-	-	12	19	-	-	-	-
15	39	-	-	12	19	-	-	-	-
15	39	-	-	12	19	-	-	-	-
15	39	-	-	12	19	-	-	-	-
-	-	14	14	-	-	35	-	-	35
10	26	-	-	8	12	-	-	-	-
10	26	-	-	8	12	-	-	-	-
10	26	-	-	8	12	-	-	-	-
-	-	9	9	-	-	23	-	-	23
7	19	-	-	6	9	-	-	-	-
7	19	-	-	6	9	-	-	-	-
7	19	-	-	6	9	-	-	-	-
7	19	-	-	6	9	-	-	-	-
7	19	-	-	6	9	-	-	-	-
5	13	-	-	4	6	-	-	-	-
5	13	-	-	4	6	-	-	-	-
5	13	-	-	4	6	-	-	-	-

Power supply and controller selection table
Tableau de sélection des sources d'alimentation et des contrôleurs

Reference Référence	Name Nom	T Kelvin	P (W)	Vdc	L(m)	W/m	Non dimmable power supply Source d'alimentation non dimmable													Dimmable controllers and power supplies Sources et contrôleurs dimmables				
							Reference Référence	71-B650	71-B651	71-B640	71-B641	71-B642	71-B643	71-B644	71-B645	71-B646	71-B647	71-B648	71-B649	Power supply voltage Tension d'alimentation	Output voltage Tension de sortie	P (W)	IP	PAG.
							Maximum number of metres which can be fed by each power supply Nombre maximum de mètres de bandeau pouvant être alimentés par chaque dispositif													Maximum number of metres which can be fed by each power supply Nombre maximum de mètres de bandeau pouvant être alimentés par chaque dispositif				
91-7930	PERFORMANCE 9,6	2700	48	24	5	9,6	1	1	2	9	14	24	2	5	9	15	23	39	30	5	14	24	5	
91-7931		3000	48	24	5	9,6	1	1	2	9	14	24	2	5	9	15	23	39	30	5	14	24	5	
91-A020		3000	48	24	5	9,6	1	1	2	9	14	24	2	5	9	15	23	39	30	5	14	24	5	
91-A017		4000	48	24	5	9,6	1	1	2	9	14	24	2	5	9	15	23	39	30	5	14	24	5	
91-A019		RGBW	48	24	5	9,6	1	1	2	9	14	24	2	5	9	15	23	39	-	-	-	-	-	
91-A021		RGBW	48	24	5	9,6	1	1	2	9	14	24	2	5	9	15	23	39	-	-	-	-	-	
91-7932	PERFORMANCE 14,2	2700	72	24	5	14,4	1	1	1	6	9	16	1	3	6	10	15	26	20	3	9	16	3	
91-7933		3000	72	24	5	14,4	1	1	1	6	9	16	1	3	6	10	15	26	20	3	9	16	3	
91-A023		3000	72	24	5	14,4	1	1	1	6	9	16	1	3	6	10	15	26	20	3	9	16	3	
91-A022		4000	72	24	5	14,4	1	1	1	6	9	16	1	3	6	10	15	26	20	3	9	16	3	
91-7937		RGB	72	24	5	14,4	1	1	1	6	9	16	1	3	6	10	15	26	-	-	-	-	-	
91-7934	PERFORMANCE 19,2	2700	96	24	5	19,2	-	-	1	4	7	12	1	2	4	7	11	19	15	2	7	12	2	
91-A024		2700	96	24	5	19,2	-	-	1	4	7	12	1	2	4	7	11	19	15	2	7	12	2	
91-7935		3000	96	24	5	19,2	-	-	1	4	7	12	1	2	4	7	11	19	15	2	7	12	2	
91-A025		3000	96	24	5	19,2	-	-	1	4	7	12	1	2	4	7	11	19	15	2	7	12	2	
91-7936		4000	96	24	5	19,2	-	-	1	4	7	12	1	2	4	7	11	19	15	2	7	12	2	
91-7938		RGBW	96	24	5	19,2	-	-	1	4	7	12	1	2	4	7	11	19	-	-	-	-	-	
91-7939	2500-6000	96	24	5	19,2	-	-	1	4	7	12	1	2	4	7	11	19	-	-	-	-	-		
91-7940	PERFORMANCE 28,8	2700	144	24	5	28,8	-	-	-	3	4	8	-	1	3	5	7	13	10	1	4	8	1	
91-7941		3000	144	24	5	28,8	-	-	-	3	4	8	-	1	3	5	7	13	10	1	4	8	1	
91-A026	ON ADVANCED COB	3000	40	24	5	8,0	2	1	3	11	17	29	3	7	11	19	28	47	37	7	17	29	7	
91-A000	ASAI 3D	3000	14	24	1	14,4	1	1	1	6	9	16	1	3	6	10	15	26	20	3	9	16	3	
91-A002		4000	14	24	1	14,4	1	1	1	6	9	16	1	3	6	10	15	26	20	3	9	16	3	
91-A001		3000	115,2	24	8	14,4	1	1	1	6	9	16	1	3	6	10	15	26	20	3	9	16	3	
91-A003		4000	115,2	24	8	14,4	1	1	1	6	9	16	1	3	6	10	15	26	20	3	9	16	3	
91-A004		RGB	14,4	24	1	14,4	1	1	1	6	9	16	1	3	6	10	15	26	-	-	-	-	-	
91-A005		RGB	115,2	24	8	14,4	1	1	1	6	9	16	1	3	6	10	15	26	-	-	-	-	-	

Dimmable controllers and power supplies Sources et contrôleurs dimmables				
DALI-2	DALI-2	DMX 4xCH	Bluetooth	Bluetooth
71-B656	71-B657	71-B755	71-8050	71-A242
-	-	12/24VDC	12/24VDC	90-305VAC
24VDC	24VDC	12/24VDC	12/24VDC	24VDC
160	400	4x2A	6A	120
67	67	20	20	67
985	985	985	985	985
Maximum number of metres which can be fed by each power supply Nombre maximum de mètres de bandeau pouvant être alimentés par chaque dispositif				
15	39	-	-	12
15	39	-	-	12
15	39	-	-	12
15	39	-	-	12
15	39	-	14	-
-	-	-	14	-
10	26	-	-	8
10	26	-	-	8
10	26	-	-	8
10	26	-	-	8
-	-	9	9	-
7	19	-	-	6
7	19	-	-	6
7	19	-	-	6
7	19	-	-	6
7	19	-	-	6
-	-	7	7	-
-	-	-	7	-
5	13	-	-	4
5	13	-	-	4
19	47	-	-	14
10	26	-	-	8
10	26	-	-	8
10	26	-	-	8
10	26	-	-	8
-	-	9	9	-
-	-	9	9	-

RF receivers with remote control Récepteurs RF avec télécommande			
RF Receiver 1 channel	RF Receiver 4 channel	RGB	White
			
71-7668	71-7669	71-7667	71-7670
12/24 Vdc	12/24 Vdc	-	-
12/24 VDC	12/24 VDC	-	-
96/192	4x5A	-	-
20	20	-	-
985	985	985	985
Maximum number of metres which can be fed by each power supply Nombre maximum de mètres de bandeau pouvant être alimentés par chaque dispositif			
19	-	-	-
19	-	-	-
19	-	-	-
19	-	-	-
-	35	-	-
-	35	-	-
12	-	-	-
12	-	-	-
12	-	-	-
12	-	-	-
-	23	-	-
9	-	-	-
9	-	-	-
9	-	-	-
9	-	-	-
9	-	-	-
-	17	-	-
-	-	-	-
6	-	-	-
6	-	-	-
22	-	-	-
12	-	-	-
12	-	-	-
12	-	-	-
12	-	-	-
-	23	-	-
-	23	-	-





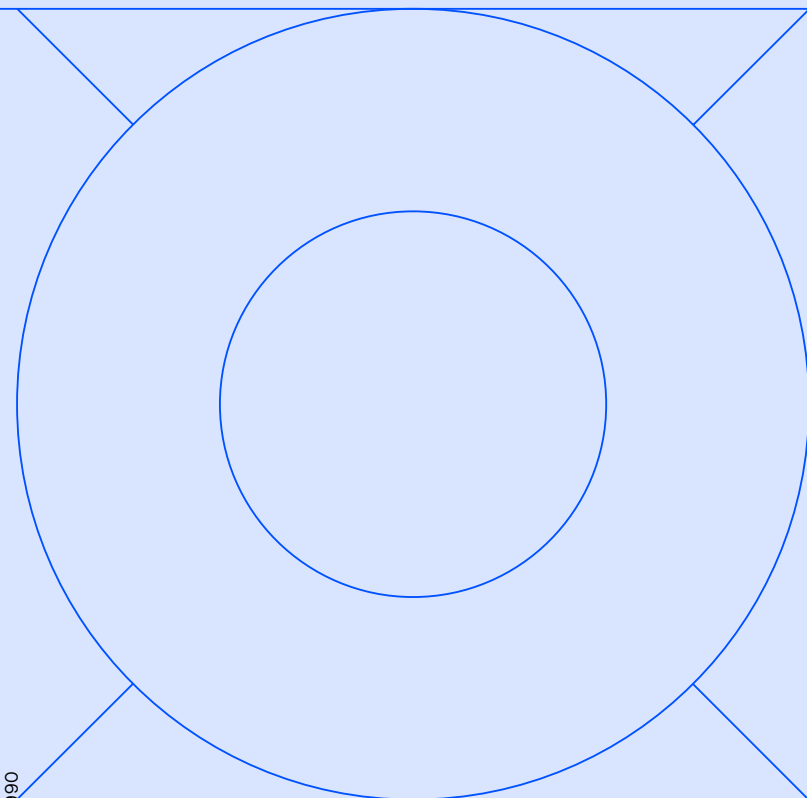

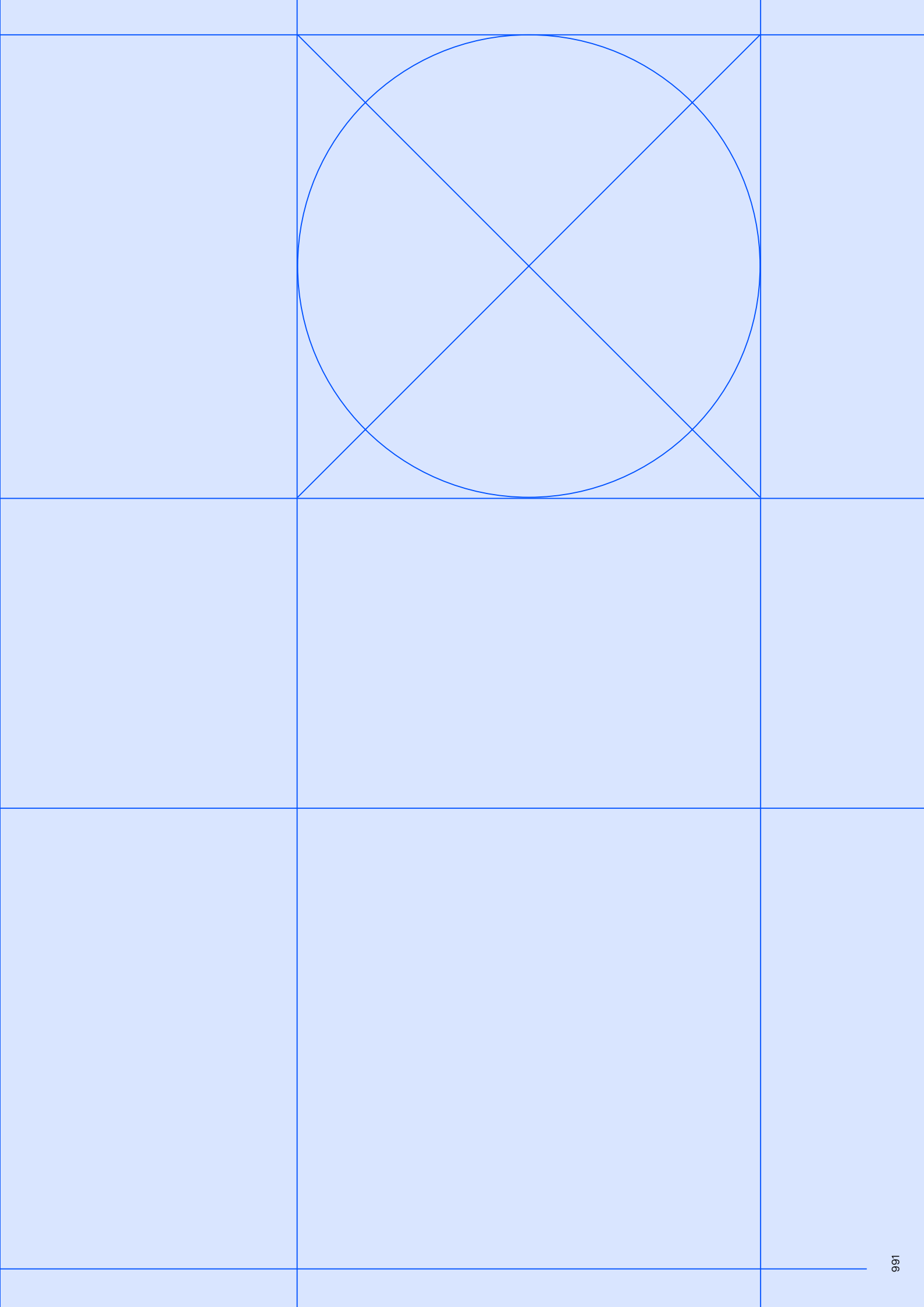

























Wall front Façade murale
PWM/RGBW

71-7664
12/24VDC
12/24VDC
4x5A
20
985
Maximum number of metres which can be fed by each power supply Nombre maximum de mètres de bandeau pouvant être alimentés par chaque dispositif
-
-
-
-
35
35
-
-
-
-
23
-
-
-
-
17
-
-
-
-
-
23
23

Extra Reader's Guide



































Finishes / Finitions

	00	White	Blanc
	01	Gold	Or
	05	Black	Noir
	06	Copper	Cuivre
	08	Green	Vert
	12	Fumé	Fumé
	14	White	Blanc
	15	Amber	Ambré
	18	Brown	Marron
	21	Chrome	Chrome
	23	Gold	Or
	27	Brass	Laitonné
	34	Grey	Gris
	37	Transparent	Transparent
	45	Matte black anodised	Noir mat anodisé
	48	Galvanised steel	Acier zingué
	54	Anodised aluminium	Aluminium anodisé
	55	Alabaster	Albâtre
	60	Black	Noir
	81	Satin nickel	Nickel satiné
	92	Dark ash	Frêne foncé
	93	Light ash	Frêne clair
	AF	Satin aluminium	Aluminium satiné
	AH	Silver	Argent
	AP	Gold	Or
	BW	White	Blanc
	BY	Sand	Sable
	B8	Satin glass	Verre satiné
	CA	AISI 316 stainless steel	Acier inox AISI 316
	CI	Brown	Marron
	CS	Cement grey	Gris ciment
	CT	Painted rust	Oxyde peint
	DC	Cement	Ciment

Finishes / Finitions

	DL	Gold	Or
	DN	Matte gold	Or mat
	DO	Polished brass	Laiton poli
	EF	Gold	Or
	EK	Dark gray	Gris foncé
	EL	White perforated fabric	Tissu blanc perforé
	EM	Stone grey	Gris pierre
	EN	Walnut wood	Bois de noyer
	EO	Oak wood	Bois de chêne
	EP	Deep gold	Or intense
	EQ	Light brown	Brun clair
	ES	Natural rattan	Rotin naturel
	ET	Painted gold	Or peint
	EU	Gloss White	Blanc brillant
	EV	Gloss Black	Noir brillant
	EX	Olive grey	Gris olive
	E3	Fir green	Vert sapin
	E4	Patina	Patiné
	F1	Sandblasted glass	Verre sablé
	F5	Gold	Or
	F9	Sandblasted	Sablé
	GA	Light grey felt	Feutre gris clair
	GB	Dark grey felt	Feutre gris foncé
	G5	Painted glass white interior	Verre peint blanc intérieur
	G7	Textured black	Noir texturé
	H13W	Black	Noir
	H2	Textured white	Blanc texturé
	I6	Brushed anodise	Anodisé gratté
	I7	Brushed anodise	Anodisé
	I8	Gun Metal PVD	Gun Metal PVD
	J6	Brown	Marron
	K3	Mirror glass	Verre miroir
	L7	Black/Black/Black	Noir/Noir/Noir

























Finishes / Finitions

	L8	Black/Gold/Gold	Noir/Or/Or
	L9	Black/Gold/Transparent	Noir/Or/Transparent
	M1	Opal white	Blanc opale
	M3	Anodised	Anodisé
	N3	Grey	Gris
	O1	White/Gold/Gold	Blanc/Or/Or
	O2	White/Gold/White	Blanc/Or/Blanc
	O3	Gold/Gold/Gold	Or/Or/Or
	O4	Gold/Gold/Transparent	Or/Or/Transparent
	O5	Black/Grey/Grey	Noir/Gris/Gris
	O6	Black/Grey/Transparent	Noir/Gris/Transparent
	O7	White/Grey/Grey	Blanc/Gris/Gris
	O8	White/Grey/Transparent	Blanc/Gris/Transparent
	O9	Grey/Grey/Grey	Gris/Gris/Gris
	P7	Grey/Grey/Transparent	Gris/Gris/Transparent
	S2	Satin aluminium	Aluminium satiné
	T007	White	Blanc
	WG	White/Gold	Blanc/Or
	WH	Black/White	Noir/Blanc
	WI	Gold/White	Or/Blanc
	WJ	Gold/Gold	Or/Or
	WK	Gold/Black	Or/Noir
	WL	Black/White	Noir/Blanc
	WM	Black/Gold	Noir/Or
	WN	Black/Black	Noir/Noir
	WP	Trimless/White	Trimless/Blanc
	WQ	Trimless/Black	Trimless/Noir
	WR	White/white	Blanc/blanc
	WS	Trimless/Gold	Trimless/Or
	WT	Trimless/White	Trimless/Blanc
	Z5	Urban grey	Gris urbain

























Materials / Matériaux

ABS	ABS	ABS
ACR	Acrylic	Acrylique
AISI202	Stainless steel AISI202	Acier inoxydable AISI 202
AISI304	Stainless steel AISI304	Acier inoxydable AISI 304
AISI316	Stainless steel AISI316	Acier inoxydable AISI 316
AL	Aluminium	Aluminium
ALAB	Alabaster	Albâtre
BR	Brass	Laiton
CON	Concrete	Ciment
FELT	Felt	Feutre
G	Graphene	Graphène
GL	Fibreglass	Fibre de verre
GLA	Glass	Verre
PC	Polycarbonate	Polycarbonate
PC+ABS	Polycarbonate + ABS	Polycarbonate + ABS
PLABS	Plastic	Plastique
PLSTER	Plaster	Plâtre
PMMA	Methacrylate	PMMA
POLI	Technopolymer	Technopolymère
PP	Polypropylene	Polypropylène
PUR	Polyurethane	Polyuréthane
PVC	PVC	PVC
R	Resin	Résine
RATAN	Rattan	Rotin
ST	Steel	Acier
TEX	Textile	Textile
WASHI	Japanese paper	Papier japonais
WOOD	Wood	Bois
WOODT	Teak wood	Teck

























Symbols / Symboles

	A coding system that shows the degree of protection that a cover provides against the penetration of solid objects or dust and liquids	Système de codification permettant d'indiquer le degré de protection procuré par une enveloppe contre la pénétration de corps solides, poussières et liquides
	New feature	Nouveauté
	Structure material	Matériau de la structure
	A coding system that shows the degree of protection that a cover provides against damaging mechanical impacts. Energy of impact (Joules)	Système de codification permettant d'indiquer le degré de protection procuré par une enveloppe contre les impacts mécaniques nuisibles. Énergie d'impact (en joules)
	Diffuser material	Matériau du diffuseur
	UGR	UGR
	Low Flicker	Low Flicker
	Class I	Classe I
	Class II	Classe II
	Class III	Classe III
	Hours of life	Heures de vie
	Compliant with the luminous efficacy required to obtain the BREEAM sustainable construction certificate, which is calculated by dividing the luminaire's luminous flux by its total power.	Conforme à l'efficacité lumineuse requise pour obtenir le certificat de construction durable BREEAM, calculée en divisant les lumens réels par la puissance totale du luminaire.
	MacAdam	MacAdam
	WELL. Contributes toward satisfying Feature LO6 under the WELL Building Standard®.	WELL. Contribue au respect du critère LO6 de la norme de construction WELL Building Standard®.
	CCT switch	Interrupteur CCT
	RGB Light	Éclairage RGB
	Luminaires should never be covered with heat insulating material	Ces luminaires ne doivent pas être recouverts de matériau thermo-isolant
	Not suitable for direct installation on normally flammable surfaces	Luminaires non destinés à un montage direct sur des surfaces normalement inflammables
	ATTENTION - This light fixture can withstand a limited static load. SUITABLE for areas where low-speed vehicles circulate. NOT SUITABLE for high-traffic areas	ATTENTION - Ce luminaire peut supporter une charge statique limitée. IL EST ADAPTÉ aux zones de circulation occasionnelle de véhicules à basse vitesse. IL N'EST PAS ADAPTÉ aux zones de circulation habituelle de véhicules.
	Max. no. of metres in serial connection	Longueur max. (en mètres) de raccordement en série
	x metres of cable	x mètres de câble
	Double cable output	Double sortie de câble
	Pre-wired (20cm) with 4 watertight quick connectors (female + female on the left and male + male on the right).	Pré-câblé (20cm) avec 4 connecteurs rapides étanches (femelle + femelle à gauche et mâle + mâle à droite).
	Pre-wired (20cm) with 2 watertight quick connectors (female on the left and male on the right).	Pré-câblé (20cm) avec 2 connecteurs rapides étanches (femelle à gauche et mâle à droite).

Symbols / Symboles

	Pre-wired (20cm) with 2 watertight quick connectors (male on the left and male on the right).	Pré-câblé (20cm) avec 2 connecteurs rapides étanches (mâle à gauche et mâle à droite)
	Pre-wired (20cm) with 1 watertight quick connector (male).	Pré-câblé (20cm) avec 1 connecteur rapide étanche (mâle).
	Pre-wired (20cm) with 1 watertight quick connector (male). Includes 1 extra pre-wired cable gland.	Pré-câblé (20cm) avec 1 connecteur rapide étanche (mâle). Comprend 1 presse-étoupe pré-câblé supplémentaire.
	Pre-wired (20cm) with 4 watertight quick connectors (all female).	Pré-câblé (20cm) avec 4 connecteurs rapides étanches (tous femelles).
	Luminaire suitable for installation in marine environments.	Luminaire adapté pour une installation en milieu marin.
	Control System DIMMABLE.	Système de régulation DIMMABLE.
	Control System NOT DIMMABLE.	Système de régulation NOT DIMMABLE.
	Drainage. See installation recommendations on page 983	Drainage. Voir les conseils d'installation à la page 983
	Includes a floor installation system developed by LedsC4 that guarantees the luminaires' strength and durability, and ensures there are no angle differences between them even if the floor surface is irregular.	Il comprend un système de fixation au sol développé par LedsC4 qui garantit la solidité et la durabilité des luminaires et l'absence de différences d'inclinaison entre eux, même si le sol est irrégulier.
	Adjustable	Orientable
	Adjustable	Orientable
	Adjustable	Orientable
	Adjustable	Orientable
	Adjustable	Orientable
	Adjustable	Orientable
	Adjustable	Orientable
	Adjustable	Orientable
	On/off switch	Interrupteur on/off
	Double on/off switch	Interrupteur double allumage
	Touch switch	Interrupteur tactile
	Light switch on cable	Interrupteur d'allumage sur le câble
	5x magnifying mirror	Miroir grossissant x 5
	3x magnifying mirror	Miroir grossissant x 3
	Remote control	Télécommande

Symbols / Symboles

	Max. no. of metres in serial connection	Longueur max. (en mètres) de raccordement en série
	Anti-fog. System included to prevent the mirror being obscured by steam.	Antibuée. Système inclus pour empêcher le miroir de s'embuer avec de la vapeur d'eau.
	The safety backing is a film applied to the reverse of the mirrors to prevent injury caused by glass in the event of breakage.	Le revêtement arrière de sécurité est un film appliqué au dos des miroirs pour éviter les blessures dues au verre en cas de casse.
	Roll-over light suitable for the passage of vehicles in accordance with EN 60598-2-13 (torsion strength and shear load tests).	Luminaire adapté au passage de véhicules selon la norme EN 60598-2-13 (essais de résistance à la torsion et à la charge de cisaillement).
	Airflow (CFM). Fan airflow measurement unit (cubic feet per minute).	Airflow (CFM). Unité de mesure du débit d'air du ventilateur (pieds cubes par minute)
	DC Motors. Direct current motor. Improved efficiency and consumption.	Moteurs CC. Moteur à courant continu. Efficacité et consommation accrues.
	Includes light source	Comprend une source lumineuse.
	Blade material	Matériau des pales
	The inverse function makes the blades turn in the opposite direction. During cold months, this allows hot air to move from the ceiling to the floor and heat up the room, thus saving energy through its use as a heating system.	La fonction inverse fait tourner les pales dans le sens opposé. Pendant les mois froids, elle permet de déplacer l'air chaud du plafond vers le sol et de chauffer la pièce en économisant de l'énergie en l'utilisant avec le système de chauffage.
	Fan speed, motor rotational speed.	Vitesse de ventilation, vitesse de rotation du moteur
	USB port	Connexion USB
	USB-C port	Connexion USB-C
	Custom cut	Découpe sur mesure
	Non-replaceable light source	Source lumineuse non remplaçable
	Light source replaceable by a qualified technician	Source lumineuse remplaçable par un technicien qualifié
	Final user replaceable light source	Source lumineuse remplaçable par l'utilisateur final
	Non-replaceable driver	Pilote lumineuse non remplaçable
	Driver replaceable by a qualified technician	Pilote remplaçable par un technicien qualifié
	Final user replaceable driver	Pilote remplaçable par l'utilisateur final
	Wireless	Sans fil
	Sensor	Capteur
	Luminaires with built-in connectivity.	Luminaires à connectivité intégrée.
	Equipment not included	Équipement non compris
	Equipment included	Équipement compris

Symbols / Symboles

	The fixings can be used on ceilings of between Xmm and Xmm	Les fixations permettent d'installer le modèle sur des plafonds de X à X mm
	Check Availability	Vérifiez la disponibilité
	Recess diameter	Diamètre d'encastrement
	Recess dimensions	Coupe d'encastrement
	The driver goes through the recess hole	Le driver passe par l'orifice d'encastrement
	The driver does not go through the recess hole	Le driver ne passe pas par l'orifice d'encastrement
	Variation in colour temperature from warm to cool white	Variation selon la température de la couleur de chaude à froide

References Index / Index des références

Reference Référence	Page Page.	Reference Référence	Page Page.	Reference Référence	Page Page.	Reference Référence	Page Page.
00-4941-XX-XX	263	05-E077-XX-XX	824, 902	05-E165-XX-XX	617	15-7186-XX-XX	309, 310
00-4944-XX-XX	263	05-E078-XX-XX	807	05-E166-XX-XX	562	15-7187-XX-XX	310
00-4947-XX-XX	263	05-E079-XX-XX	807	10-E001-XX-XX	895	15-7188-XX-XX	310
00-4950-XX-XX	263	05-E080-XX-XX	807	10-E002-XX-XX	895	15-7189-XX-XX	310
00-4953-XX-XX	263	05-E081-XX-XX	806	10-E003-XX-XX	895	15-7190-XX-XX	310
00-4962-XX-XX	263	05-E082-XX-XX	824, 902	10-E004-XX-XX	898	15-7191-XX-XX	310
00-9155-XX-XX	912	05-E083-XX-XX	562	10-E005-XX-XX	898	15-7192-XX-XX	310
00-9156-XX-XX	912	05-E086-XX-XX	805	10-E006-XX-XX	898	15-7193-XX-XX	310
05-1804-XX-XX	409	05-E087-XX-XX	826, 906	10-E007-XX-XX	898	15-7194-XX-XX	310
05-8764-XX-XX	961	05-E088-XX-XX	824, 902	10-E008-XX-XX	898	15-7195-XX-XX	310
05-8765-XX-XX	961	05-E089-XX-XX	824, 902	10-E009-XX-XX	898	15-7196-XX-XX	310
05-8766-XX-XX	961	05-E090-XX-XX	627, 829	10-E010-XX-XX	895	15-7197-XX-XX	310
05-8767-XX-XX	961	05-E092-XX-XX	809	10-E011-XX-XX	895	15-7198-XX-XX	310
05-E007-XX-XX	570	05-E099-XX-XX	516	10-E012-XX-XX	895	15-7199-XX-XX	310
05-E008-XX-XX	570	05-E101-XX-XX	562	10-E013-XX-XX	733	15-7200-XX-XX	310
05-E009-XX-XX	570	05-E102-XX-XX	848	10-E014-XX-XX	896	15-7201-XX-XX	310
05-E010-XX-XX	570	05-E103-XX-XX	516	10-E015-XX-XX	896	15-7202-XX-XX	310
05-E011-XX-XX	570	05-E108-XX-XX	407, 622	10-E016-XX-XX	757	15-7203-XX-XX	310
05-E013-XX-XX	570	05-E109-XX-XX	840	10-E017-XX-XX	896	15-7204-XX-XX	310
05-E014-XX-XX	407, 622	05-E110-XX-XX	407, 622	10-E018-XX-XX	733	15-7305-XX-XX	296
05-E015-XX-XX	406, 621	05-E111-XX-XX	406, 621	10-E019-XX-XX	887	15-7306-XX-XX	296
05-E016-XX-XX	406, 621	05-E112-XX-XX	405, 620	10-E020-XX-XX	887	15-7307-XX-XX	296
05-E017-XX-XX	405, 620	05-E127-XX-XX	617	10-E021-XX-XX	888	15-7308-XX-XX	296
05-E020-XX-XX	809	05-E128-XX-XX	617	10-E023-XX-XX	723	15-7309-XX-XX	296
05-E021-XX-XX	809	05-E129-XX-XX	617	10-E024-XX-XX	723	15-7310-XX-XX	296
05-E026-XX-XX	814	05-E134-XX-XX	617	10-E025-XX-XX	723	15-7885-XX-XX	146
05-E027-XX-XX	815	05-E135-XX-XX	617	10-E026-XX-XX	724	15-7886-XX-XX	146
05-E028-XX-XX	840	05-E136-XX-XX	617	10-E027-XX-XX	724	15-7888-XX-XX	146
05-E031-XX-XX	626	05-E137-XX-XX	843	10-E028-XX-XX	724	15-7889-XX-XX	146
05-E046-XX-XX	582	05-E138-XX-XX	843	10-E029-XX-XX	920	15-8035-XX-XX	313
05-E047-XX-XX	809	05-E139-XX-XX	842	10-E030-XX-XX	882	15-8036-XX-XX	313
05-E048-XX-XX	809	05-E140-XX-XX	842	10-E031-XX-XX	882	15-8037-XX-XX	313
05-E052-XX-XX	805	05-E141-XX-XX	402, 614	10-E032-XX-XX	882	15-8038-XX-XX	313
05-E054-XX-XX	813	05-E144-XX-XX	843	10-E033-XX-XX	882	15-9480-XX-XX	868
05-E055-XX-XX	840	05-E145-XX-XX	843	10-E053-XX-XX	765	15-9619-XX-XX	872
05-E056-XX-XX	811	05-E146-XX-XX	625	10-E057-XX-XX	733	15-9790-XX-XX	860
05-E057-XX-XX	582	05-E147-XX-XX	625	10-E077-XX-XX	821	15-9806-XX-XX	872
05-E058-XX-XX	833	05-E148-XX-XX	799	15-5946-XX-XX	282	15-9835-XX-XX	849
05-E059-XX-XX	833	05-E149-XX-XX	801	15-6282-XX-XX	295	15-9904-XX-XX	861
05-E060-XX-XX	580	05-E150-XX-XX	799	15-6283-XX-XX	295	15-9948-XX-XX	610
05-E061-XX-XX	580	05-E151-XX-XX	800	15-6284-XX-XX	295	15-A003-XX-XX	278, 941
05-E062-XX-XX	555, 713, 784, 864	05-E152-XX-XX	570	15-6485-XX-XX	295	15-A018-XX-XX	296
05-E063-XX-XX	555, 784, 864	05-E153-XX-XX	570	15-6486-XX-XX	295	15-A019-XX-XX	296
05-E064-XX-XX	555, 784, 864	05-E154-XX-XX	570	15-6487-XX-XX	295	15-A020-XX-XX	296
05-E065-XX-XX	819	05-E155-XX-XX	552	15-7098-XX-XX	309, 310	15-A024-XX-XX	296
05-E068-XX-XX	833	05-E157-XX-XX	797	15-7099-XX-XX	309, 310	15-A025-XX-XX	296
05-E069-XX-XX	836	05-E158-XX-XX	797	15-7100-XX-XX	309, 310	15-A026-XX-XX	296
05-E070-XX-XX	809	05-E159-XX-XX	797	15-7101-XX-XX	309, 310	15-A041-XX-XX	146
05-E071-XX-XX	824, 902	05-E161-XX-XX	919	15-7161-XX-XX	309, 310	15-A042-XX-XX	146
05-E076-XX-XX	824, 902	05-E162-XX-XX	814	15-7169-XX-XX	309, 310	15-A043-XX-XX	146
		05-E163-XX-XX	510	15-7184-XX-XX	309, 310	15-A044-XX-XX	146
		05-E164-XX-XX	510	15-7185-XX-XX	309, 310	15-A065-XX-XX	295

References Index / Index des références

Reference Référence	Page Page.	Reference Référence	Page Page.	Reference Référence	Page Page.	Reference Référence	Page Page.
15-A066-XX-XX	295	15-A182-XX-XX	297	25-E019-XX-XX	889	35-A017-XX-XX	084
15-A067-XX-XX	295	15-A183-XX-XX	297	25-E020-XX-XX	890	35-A018-XX-XX	083
15-A068-XX-XX	295	15-A184-XX-XX	297	25-E021-XX-XX	891	35-A019-XX-XX	083
15-A069-XX-XX	295	15-A185-XX-XX	297	25-E022-XX-XX	891	35-A020-XX-XX	083
15-A070-XX-XX	295	15-A186-XX-XX	297	25-E023-XX-XX	891	35-A021-XX-XX	082
15-A071-XX-XX	295	15-A187-XX-XX	298	35-6276-XX-XX	081	35-A022-XX-XX	082
15-A072-XX-XX	295	15-A188-XX-XX	298	35-6277-XX-XX	081	35-A023-XX-XX	082
15-A073-XX-XX	295	15-A189-XX-XX	298	35-6278-XX-XX	081	35-A051-XX-XX	083
15-A080-XX-XX	296	15-A190-XX-XX	298	35-6282-XX-XX	081	35-A052-XX-XX	083
15-A081-XX-XX	296	15-A191-XX-XX	298	35-6283-XX-XX	081	35-A053-XX-XX	083
15-A082-XX-XX	296	15-A192-XX-XX	298	35-6284-XX-XX	081	35-A054-XX-XX	091
15-A083-XX-XX	296	15-A193-XX-XX	298	35-6288-XX-XX	081	35-A055-XX-XX	091
15-A084-XX-XX	296	15-A194-XX-XX	298	35-6289-XX-XX	081	35-A056-XX-XX	091
15-A085-XX-XX	296	15-A195-XX-XX	298	35-6290-XX-XX	081	35-A057-XX-XX	091
15-A086-XX-XX	296	15-A196-XX-XX	298	35-7279-XX-XX	141	35-A058-XX-XX	091
15-A087-XX-XX	296	15-A197-XX-XX	298	35-7280-XX-XX	141	35-A059-XX-XX	091
15-A088-XX-XX	296	15-A198-XX-XX	298	35-7281-XX-XX	141	35-A060-XX-XX	082
15-A092-XX-XX	296, 297	15-A199-XX-XX	298	35-7282-XX-XX	141	35-A061-XX-XX	082
15-A093-XX-XX	296, 297	15-A200-XX-XX	298	35-7283-XX-XX	141	35-A062-XX-XX	082
15-A094-XX-XX	296, 297	15-A201-XX-XX	298	35-7284-XX-XX	141	35-A063-XX-XX	141
15-A095-XX-XX	295	15-A203-XX-XX	298	35-7285-XX-XX	141	35-A064-XX-XX	141
15-A096-XX-XX	295	15-A204-XX-XX	298	35-7286-XX-XX	141	35-A066-XX-XX	082
15-A097-XX-XX	295	15-A205-XX-XX	298	35-7287-XX-XX	082	35-A067-XX-XX	082
15-A098-XX-XX	295	15-A207-XX-XX	298	35-7288-XX-XX	082	35-A068-XX-XX	082
15-A099-XX-XX	295	15-A208-XX-XX	298	35-7289-XX-XX	082	35-A072-XX-XX	141
15-A100-XX-XX	295	15-A209-XX-XX	298	35-7290-XX-XX	082	35-A073-XX-XX	141
15-A116-XX-XX	311, 873	15-E020-XX-XX	860	35-7291-XX-XX	082	35-A075-XX-XX	084
15-A117-XX-XX	311, 873	15-E035-XX-XX	606	35-7292-XX-XX	082	35-A077-XX-XX	084
15-A118-XX-XX	311, 873	15-E036-XX-XX	606	35-7305-XX-XX	083	35-A078-XX-XX	084
15-A119-XX-XX	311, 873	15-E041-XX-XX	849	35-7306-XX-XX	083	35-A079-XX-XX	084
15-A120-XX-XX	311, 873	15-E049-XX-XX	848	35-7307-XX-XX	083	35-A090-XX-XX	094
15-A121-XX-XX	311, 873	15-E050-XX-XX	848	35-7308-XX-XX	083	35-A091-XX-XX	094
15-A122-XX-XX	311, 873	15-E064-XX-XX	857	35-7309-XX-XX	083	35-A092-XX-XX	094
15-A123-XX-XX	311, 873	15-E065-XX-XX	609	35-7310-XX-XX	083	35-A093-XX-XX	094
15-A124-XX-XX	311, 873	15-E104-XX-XX	607	35-7323-XX-XX	084	35-A094-XX-XX	094
15-A149-XX-XX	147	15-E105-XX-XX	607	35-7324-XX-XX	084	35-A095-XX-XX	094
15-A150-XX-XX	147	15-E110-XX-XX	871	35-7325-XX-XX	084	35-A096-XX-XX	094
15-A151-XX-XX	147	15-E111-XX-XX	871	35-7326-XX-XX	084	35-A097-XX-XX	094
15-A152-XX-XX	147	25-9733-XX-XX	737	35-7327-XX-XX	084	35-A098-XX-XX	094
15-A169-XX-XX	297	25-E000-XX-XX	899	35-7328-XX-XX	084	35-A118-XX-XX	095
15-A170-XX-XX	297	25-E001-XX-XX	899	35-8035-XX-XX	143	35-A120-XX-XX	095
15-A171-XX-XX	297	25-E002-XX-XX	899	35-8036-XX-XX	143	35-A122-XX-XX	095
15-A172-XX-XX	297	25-E006-XX-XX	898	35-8037-XX-XX	143	35-A123-XX-XX	095
15-A173-XX-XX	297	25-E007-XX-XX	898	35-8038-XX-XX	143	35-A124-XX-XX	095
15-A174-XX-XX	297	25-E008-XX-XX	898	35-A003-XX-XX	082	35-A125-XX-XX	095
15-A175-XX-XX	297	25-E009-XX-XX	896	35-A004-XX-XX	082	35-A126-XX-XX	095
15-A176-XX-XX	297	25-E010-XX-XX	896	35-A005-XX-XX	082	35-A127-XX-XX	095
15-A177-XX-XX	297	25-E011-XX-XX	896	35-A009-XX-XX	083	35-A128-XX-XX	095
15-A178-XX-XX	297	25-E012-XX-XX	896	35-A010-XX-XX	083	35-A129-XX-XX	095
15-A179-XX-XX	297	25-E013-XX-XX	896	35-A011-XX-XX	083	35-A130-XX-XX	095
15-A180-XX-XX	297	25-E014-XX-XX	896	35-A015-XX-XX	084	35-A131-XX-XX	095
15-A181-XX-XX	297	25-E018-XX-XX	889	35-A016-XX-XX	084	35-A135-XX-XX	145

References Index / Index des références

Reference Référence	Page Page.	Reference Référence	Page Page.	Reference Référence	Page Page.	Reference Référence	Page Page.
35-A136-XX-XX	145	35-A188-XX-XX	082	55-9380-XX-XX	664	55-E029-XX-XX	751
35-A137-XX-XX	145	35-A189-XX-XX	082	55-9428-XX-XX	683	55-E030-XX-XX	751
35-A138-XX-XX	145	35-A190-XX-XX	082	55-9440-XX-XX	772	55-E031-XX-XX	751, 752
35-A139-XX-XX	306	35-A191-XX-XX	082	55-9481-XX-XX	913	55-E032-XX-XX	751, 752
35-A140-XX-XX	306	35-A192-XX-XX	082	55-9488-XX-XX	771	55-E033-XX-XX	751, 752
35-A141-XX-XX	306	35-A193-XX-XX	082	55-9504-XX-XX	759	55-E034-XX-XX	688
35-A142-XX-XX	307	35-A194-XX-XX	082	55-9549-XX-XX	771	55-E035-XX-XX	753
35-A143-XX-XX	307	35-A195-XX-XX	082	55-9620-XX-XX	660	55-E036-XX-XX	753
35-A144-XX-XX	307	35-A196-XX-XX	083	55-9655-XX-XX	773	55-E037-XX-XX	753
35-A145-XX-XX	307	35-A197-XX-XX	083	55-9656-XX-XX	773	55-E038-XX-XX	664
35-A146-XX-XX	306	35-A198-XX-XX	083	55-9663-XX-XX	659	55-E053-XX-XX	765
35-A147-XX-XX	307	35-A199-XX-XX	083	55-9665-XX-XX	659	55-E054-XX-XX	757
35-A148-XX-XX	307	35-A200-XX-XX	083	55-9667-XX-XX	659	55-E056-XX-XX	765
35-A149-XX-XX	307	35-A201-XX-XX	083	55-9733-XX-XX	737	55-E057-XX-XX	900
35-A150-XX-XX	307	35-A202-XX-XX	083	55-9741-XX-XX	693	55-E058-XX-XX	900
35-A151-XX-XX	306	35-A203-XX-XX	083	55-9768-XX-XX	660	55-E059-XX-XX	900
35-A152-XX-XX	307	35-A204-XX-XX	083	55-9769-XX-XX	660	55-E060-XX-XX	900
35-A153-XX-XX	307	35-A205-XX-XX	084	55-9791-XX-XX	758	55-E061-XX-XX	900
35-A154-XX-XX	307	35-A206-XX-XX	084	55-9792-XX-XX	594	55-E062-XX-XX	900
35-A155-XX-XX	307	35-A207-XX-XX	084	55-9873-XX-XX	768	55-E063-XX-XX	900
35-A156-XX-XX	148	35-A208-XX-XX	084	55-9880-XX-XX	909	55-E064-XX-XX	900
35-A157-XX-XX	148	35-A209-XX-XX	084	55-9883-XX-XX	693	55-E065-XX-XX	900
35-A158-XX-XX	147	35-A210-XX-XX	084	55-9906-XX-XX	654	55-E066-XX-XX	901
35-A159-XX-XX	147	35-A211-XX-XX	084	55-9907-XX-XX	654	55-E067-XX-XX	901
35-A160-XX-XX	147	35-A212-XX-XX	084	55-9908-XX-XX	657	55-E068-XX-XX	901
35-A161-XX-XX	147	35-A213-XX-XX	084	55-9909-XX-XX	654	55-E071-XX-XX	688
35-A162-XX-XX	147	35-A214-XX-XX	141	55-9910-XX-XX	657	55-E074-XX-XX	517
35-A163-XX-XX	147	35-A215-XX-XX	141	55-9938-XX-XX	769	55-E075-XX-XX	717
35-A164-XX-XX	147	35-A216-XX-XX	141	55-9939-XX-XX	769	55-E077-XX-XX	717
35-A165-XX-XX	147	35-A217-XX-XX	141	55-9945-XX-XX	691	55-E078-XX-XX	654
35-A166-XX-XX	094	35-A218-XX-XX	141	55-9946-XX-XX	691	55-E079-XX-XX	654
35-A167-XX-XX	094	35-A219-XX-XX	141	55-9947-XX-XX	691	55-E080-XX-XX	654
35-A168-XX-XX	094	35-A220-XX-XX	307	55-9971-XX-XX	766	55-E081-XX-XX	657
35-A169-XX-XX	094	35-A221-XX-XX	307	55-9972-XX-XX	654	55-E082-XX-XX	657
35-A170-XX-XX	094	35-A222-XX-XX	307	55-E001-XX-XX	680	55-E083-XX-XX	664
35-A171-XX-XX	094	35-A223-XX-XX	307	55-E002-XX-XX	680	55-E084-XX-XX	721
35-A172-XX-XX	094	35-A224-XX-XX	307	55-E003-XX-XX	680	55-E085-XX-XX	721
35-A173-XX-XX	094	35-A225-XX-XX	307	55-E006-XX-XX	675	55-E086-XX-XX	721
35-A174-XX-XX	094	35-A226-XX-XX	307	55-E010-XX-XX	666	55-E087-XX-XX	906
35-A175-XX-XX	094	35-A227-XX-XX	307	55-E011-XX-XX	667	55-E088-XX-XX	906
35-A176-XX-XX	094	35-A228-XX-XX	307	55-E012-XX-XX	763	55-E089-XX-XX	722
35-A177-XX-XX	094	55-1573-XX-XX	410	55-E016-XX-XX	757	55-E090-XX-XX	722
35-A178-XX-XX	095	55-1574-XX-XX	410	55-E019-XX-XX	763	55-E091-XX-XX	722
35-A179-XX-XX	095	55-9155-XX-XX	913	55-E020-XX-XX	667	55-E092-XX-XX	728
35-A180-XX-XX	095	55-9156-XX-XX	913	55-E021-XX-XX	502	55-E097-XX-XX	725
35-A181-XX-XX	091	55-9239-XX-XX	772	55-E022-XX-XX	710	55-E098-XX-XX	725
35-A182-XX-XX	091	55-9245-XX-XX	594	55-E023-XX-XX	710	55-E099-XX-XX	725
35-A183-XX-XX	091	55-9280-XX-XX	664	55-E024-XX-XX	712	55-E100-XX-XX	717
35-A184-XX-XX	091	55-9281-XX-XX	664	55-E025-XX-XX	750	55-E102-XX-XX	683
35-A185-XX-XX	091	55-9318-XX-XX	774	55-E026-XX-XX	750	55-E103-XX-XX	717
35-A186-XX-XX	091	55-9319-XX-XX	774	55-E027-XX-XX	750	55-E104-XX-XX	705
35-A187-XX-XX	082	55-9320-XX-XX	774	55-E028-XX-XX	751	55-E105-XX-XX	705

References Index / Index des références

Reference Référence	Page Page.	Reference Référence	Page Page.	Reference Référence	Page Page.	Reference Référence	Page Page.
55-E106-XX-XX	705	71-5221-XX-XX	104	71-5772-XX-XX	393, 394, 397	71-6288-XX-XX	85
55-E109-XX-XX	517	71-5222-XX-XX	104	71-5773-XX-XX	393, 394, 397	71-6289-XX-XX	85
55-E110-XX-XX	746	71-5223-XX-XX	104	71-5774-XX-XX	393, 394, 397	71-6290-XX-XX	85
55-E111-XX-XX	746	71-5224-XX-XX	104	71-5775-XX-XX	393, 394	71-6436-XX-XX	85, 142, 299, 305, 308
55-E112-XX-XX	919	71-5225-XX-XX	103, 106	71-5776-XX-XX	393, 394	71-6437-XX-XX	85, 299, 305, 308
55-E113-XX-XX	920	71-5227-XX-XX	104	71-5777-XX-XX	393, 394	71-6438-XX-XX	85
55-E114-XX-XX	511	71-5228-XX-XX	104	71-5778-XX-XX	393, 394	71-6607-XX-XX	419, 507
55-E115-XX-XX	511	71-5229-XX-XX	104	71-5779-XX-XX	393, 394	71-6608-XX-XX	419, 507
55-E117-XX-XX	502	71-5230-XX-XX	104	71-5780-XX-XX	393, 394	71-6652-XX-XX	246, 299, 305, 308, 546, 634, 602, 743
55-E118-XX-XX	502	71-5231-XX-XX	104	71-5781-XX-XX	393, 394	71-6653-XX-XX	183, 238, 305
55-E119-XX-XX	502	71-5232-XX-XX	104	71-5782-XX-XX	392, 393, 394, 396, 397	71-6658-XX-XX	183, 238, 240, 242, 408, 697, 623
55-E120-XX-XX	502	71-5486-XX-XX	393, 394	71-5783-XX-XX	392, 393, 394, 396, 397	71-6661-XX-XX	305
55-E148-XX-XX	672	71-5511-XX-XX	394	71-5784-XX-XX	393, 394	71-7518-XX-XX	364
55-E149-XX-XX	672	71-5608-XX-XX	397	71-5785-XX-XX	392, 393, 394	71-7520-XX-XX	103, 155, 161, 164, 258, 259, 364, 365
55-E150-XX-XX	672	71-5609-XX-XX	397	71-5786-XX-XX	393	71-7521-XX-XX	106, 155, 161, 164, 258, 259, 364, 365
55-E151-XX-XX	675	71-5658-XX-XX	87, 144, 219, 228, 270, 276, 277	71-5787-XX-XX	393	71-7522-XX-XX	242
60-3239-XX-XX	775	71-5738-XX-XX	390	71-5788-XX-XX	393	71-7523-XX-XX	242
60-9913-XX-XX	776	71-5739-XX-XX	390	71-5789-XX-XX	397	71-7534-XX-XX	106
60-9996-XX-XX	776	71-5740-XX-XX	390	71-6099-XX-XX	87, 144, 219, 228, 270, 276, 277, 949, 952	71-7535-XX-XX	106
60-E000-XX-XX	779	71-5741-XX-XX	390	71-6192-XX-XX	240, 242	71-7536-XX-XX	106
60-E001-XX-XX	729	71-5742-XX-XX	390	71-6273-XX-XX	85, 142, 299, 305, 308	71-7537-XX-XX	106
60-E082-XX-XX	776	71-5743-XX-XX	390	71-6274-XX-XX	85, 142, 299, 305, 308	71-7538-XX-XX	107
60-E102-XX-XX	779	71-5744-XX-XX	390	71-6275-XX-XX	85, 142, 299, 305, 308	71-7539-XX-XX	107
71-3223-XX-XX	284	71-5745-XX-XX	390	71-6276-XX-XX	85, 142, 299, 305, 308	71-7540-XX-XX	107
71-3454-XX-XX	376	71-5746-XX-XX	390	71-6277-XX-XX	85, 142, 299, 305, 308	71-7541-XX-XX	107
71-3531-XX-XX	263, 284	71-5747-XX-XX	391	71-6279-XX-XX	85, 299, 305, 308	71-7542-XX-XX	107
71-3542-XX-XX	309, 409, 546, 581, 634, 602, 743	71-5748-XX-XX	391	71-6280-XX-XX	85, 299, 305, 308	71-7543-XX-XX	107
71-4706-XX-XX	309, 409	71-5749-XX-XX	391	71-6281-XX-XX	85, 299, 305, 308	71-7544-XX-XX	107
71-4754-XX-XX	219, 228, 949, 952	71-5753-XX-XX	391	71-6282-XX-XX	85, 299, 305, 308	71-7545-XX-XX	107
71-4898-XX-XX	246, 305, 308, 309, 408, 409, 623	71-5754-XX-XX	391	71-6283-XX-XX	85, 299, 305, 308	71-7546-XX-XX	107
71-4914-XX-XX	537, 581	71-5755-XX-XX	391	71-6285-XX-XX	85	71-7547-XX-XX	107
71-5166-XX-XX	087, 144, 219, 228, 270, 276, 277	71-5756-XX-XX	397	71-6287-XX-XX	85	71-7551-XX-XX	305, 308, 546, 634, 602, 743
71-5167-XX-XX	087, 144, 219, 228, 270, 276, 277	71-5757-XX-XX	392, 393, 394, 396, 397			71-7579-XX-XX	546
71-5210-XX-XX	103	71-5758-XX-XX	392, 393, 394, 396, 397			71-7624-XX-XX	154
71-5211-XX-XX	103	71-5759-XX-XX	395			71-7625-XX-XX	154
71-5213-XX-XX	103	71-5760-XX-XX	395			71-7626-XX-XX	154
71-5214-XX-XX	104	71-5761-XX-XX	395			71-7627-XX-XX	155
71-5215-XX-XX	104	71-5762-XX-XX	395			71-7629-XX-XX	155
71-5216-XX-XX	104	71-5763-XX-XX	395			71-7630-XX-XX	158
71-5217-XX-XX	104	71-5764-XX-XX	395			71-7631-XX-XX	158
71-5218-XX-XX	103	71-5765-XX-XX	394				
71-5219-XX-XX	104	71-5766-XX-XX	393				
71-5220-XX-XX	104	71-5767-XX-XX	394				
		71-5768-XX-XX	393				
		71-5770-XX-XX	393				
		71-5771-XX-XX	393, 394, 397				

References Index / Index des références

Reference Référence	Page Page.	Reference Référence	Page Page.	Reference Référence	Page Page.	Reference Référence	Page Page.
71-7632-XX-XX	158	71-8130-XX-XX	377	71-A244-XX-XX	155	71-A955-XX-XX	364, 365, 956, 957, 958
71-7633-XX-XX	159	71-8131-XX-XX	377	71-A245-XX-XX	155		
71-7634-XX-XX	158, 168	71-8132-XX-XX	377	71-A246-XX-XX	155		
71-7637-XX-XX	155, 158, 162	71-8219-XX-XX	759	71-A247-XX-XX	155	71-A956-XX-XX	365
71-7639-XX-XX	155	71-8332-XX-XX	888, 897	71-A248-XX-XX	159	71-B077-XX-XX	154, 158, 161, 164, 167, 170
71-7640-XX-XX	394	71-9199-XX-XX	408, 545, 571, 575, 595, 635, 652, 655, 657, 661, 665, 667, 673, 625, 603, 741, 822, 825, 901, 903	71-A249-XX-XX	159		
71-7656-XX-XX	103, 106			71-A250-XX-XX	159	71-B078-XX-XX	154, 158, 161, 164, 167, 170
71-7663-XX-XX	183, 238, 240, 242, 305, 308, 309			71-A251-XX-XX	159		
				71-A252-XX-XX	162		
71-7676-XX-XX	155, 171			71-A253-XX-XX	162	71-B079-XX-XX	154, 158, 161, 164, 167, 170, 593
71-7698-XX-XX	419, 507	71-9262-XX-XX	408, 571, 575, 661, 625	71-A258-XX-XX	154, 158, 161, 164, 167, 170, 591, 593, 641		
71-7705-XX-XX	156, 159					71-B219-XX-XX	104
71-7706-XX-XX	159	71-9746-XX-XX	537, 564, 565, 567, 575, 581, 583	71-A259-XX-XX	154, 158, 161, 164, 167, 170, 591, 593, 641	71-B232-XX-XX	183, 240, 242, 305, 309, 581, 697
71-7891-XX-XX	219						
71-7892-XX-XX	219	71-9955-XX-XX	774	71-A260-XX-XX	183, 238, 240, 242, 246	71-B233-XX-XX	148
71-7893-XX-XX	219	71-9957-XX-XX	729			71-B245-XX-XX	155, 161, 164
71-7894-XX-XX	219	71-9997-XX-XX	489, 537, 545, 552, 557, 564, 565, 567, 571, 581, 593, 723, 724, 786, 866, 888, 890, 901	71-A261-XX-XX	183, 238, 240, 242	71-B249-XX-XX	392, 393
71-7895-XX-XX	87, 144, 219, 228, 270, 276, 277, 949, 952			71-A296-XX-XX	376	71-B252-XX-XX	393
71-8030-XX-XX	156, 159, 162, 165, 168, 171	71-9998-XX-XX	489, 537, 552, 564, 565, 567, 571, 581, 593, 721, 722, 901	71-A297-XX-XX	246, 299, 305, 308	71-B253-XX-XX	393
						71-B324-XX-XX	373
71-8031-XX-XX	156, 159, 162, 165, 168, 171			71-A298-XX-XX	305, 308	71-B332-XX-XX	238, 308
71-8032-XX-XX	156, 159, 162, 165, 168, 171	71-9999-XX-XX	537, 564, 565, 567, 575, 581, 583	71-A299-XX-XX	183, 238, 242, 305	71-B350-XX-XX	149, 161
						71-B407-XX-XX	246, 305, 308
71-8043-XX-XX	161			71-A303-XX-XX	305	71-B421-XX-XX	426, 428
71-8044-XX-XX	161	71-A177-XX-XX	91, 177	71-A329-XX-XX	258, 259, 967	71-B422-XX-XX	426, 428
71-8045-XX-XX	161	71-A190-XX-XX	183, 238, 240, 242, 305, 309, 546, 581, 634, 602, 743			71-B424-XX-XX	426
71-8046-XX-XX	162			71-A330-XX-XX	258, 259, 967	71-B440-XX-XX	154, 158, 161, 164, 167, 170
71-8047-XX-XX	162			71-A331-XX-XX	258, 259, 967		
71-8082-XX-XX	391					71-B441-XX-XX	154, 158, 161, 164, 167, 170
71-8083-XX-XX	391			71-A332-XX-XX	258, 259, 967	71-B449-XX-XX	427
71-8084-XX-XX	391			71-A333-XX-XX	258, 259, 967	71-B450-XX-XX	427
71-8092-XX-XX	425			71-A334-XX-XX	156, 159	71-B451-XX-XX	427
71-8093-XX-XX	425	71-A191-XX-XX	299, 305, 308, 409, 546, 602, 743	71-A652-XX-XX	246, 546, 634, 602, 743	71-B452-XX-XX	427
71-8094-XX-XX	425					71-B456-XX-XX	419, 507
71-8095-XX-XX	425			71-A724-XX-XX	258, 259, 967	71-B457-XX-XX	419, 507
71-8096-XX-XX	425, 426					71-B458-XX-XX	419, 507
71-8097-XX-XX	425, 426	71-A192-XX-XX	183, 238, 305, 308, 408, 546, 697, 634, 623, 602, 743	71-A854-XX-XX	249, 287	71-B471-XX-XX	168
71-8098-XX-XX	425			71-A855-XX-XX	177, 249, 287	71-B472-XX-XX	165
71-8099-XX-XX	425, 426			71-A938-XX-XX	352	71-B473-XX-XX	171
71-8112-XX-XX	365	71-A223-XX-XX	956, 957, 958, 967	71-A939-XX-XX	352, 956, 957, 958	71-B474-XX-XX	168
71-8113-XX-XX	364					71-B475-XX-XX	164, 168, 171
71-8114-XX-XX	365	71-A228-XX-XX	956, 957, 958, 967	71-A940-XX-XX	352, 956, 958	71-B476-XX-XX	165, 168, 171
71-8115-XX-XX	142					71-B477-XX-XX	165, 168, 171
71-8124-XX-XX	162	71-A229-XX-XX	238			71-B482-XX-XX	393
71-8129-XX-XX	376						

References Index / Index des références

Reference Référence	Page Page.	Reference Référence	Page Page.	Reference Référence	Page Page.	Reference Référence	Page Page.
71-B502-XX-XX	155, 171	71-B648-XX-XX	494, 503, 512, 525, 546, 634, 602, 743	71-B687-XX-XX	165, 171	71-E080-XX-XX	546, 697, 634, 602, 743
71-B503-XX-XX	103, 106			71-B688-XX-XX	165, 171		
71-B504-XX-XX	103, 106, 155, 162, 171, 364	71-B649-XX-XX	525	71-B689-XX-XX	165, 171	71-E083-XX-XX	546, 634, 602, 743
71-B523-XX-XX	393	71-B650-XX-XX	503, 512, 546, 570, 688, 634, 673, 676, 681, 602, 743	71-B690-XX-XX	168	71-E085-XX-XX	546, 634, 602, 743
71-B591-XX-XX	170			71-B691-XX-XX	168		
71-B592-XX-XX	170	71-B652-XX-XX	503, 512, 525, 546, 570, 688, 634, 602, 743	71-B692-XX-XX	168	71-E086-XX-XX	581, 697
71-B593-XX-XX	170			71-B693-XX-XX	168	71-E090-XX-XX	627, 829
71-B594-XX-XX	167	71-B653-XX-XX	503, 512, 525, 546, 570, 634, 602, 743	71-B702-XX-XX	395	71-E092-XX-XX	728, 753, 763
71-B595-XX-XX	167			71-B703-XX-XX	395		
71-B596-XX-XX	167	71-B654-XX-XX	503, 512, 525, 546, 634, 602, 743	71-B704-XX-XX	395	71-E104-XX-XX	607
71-B613-XX-XX	165, 171			71-B705-XX-XX	397	71-E105-XX-XX	607
71-B637-XX-XX	364	71-B655-XX-XX	494, 503, 512, 525, 546, 570, 688, 634, 602, 743	71-B706-XX-XX	395	71-E112-XX-XX	408, 495, 503, 545, 552, 571, 575, 581, 591, 593, 595, 689, 635, 641, 652, 655, 657, 661, 665, 667, 673, 676, 625, 603, 609, 741, 822, 825, 901, 903
71-B638-XX-XX	365			71-B707-XX-XX	395		
71-B639-XX-XX	162	71-B656-XX-XX	494, 503, 512, 525, 546, 570, 688, 634, 602, 743	71-B708-XX-XX	395	71-E117-XX-XX	729, 775, 777, 779
71-B640-XX-XX	503, 512, 546, 570, 688, 634, 673, 676, 681, 602, 743			71-B709-XX-XX	397	71-E118-XX-XX	503
71-B641-XX-XX	503, 512, 525, 546, 570, 591, 688, 634, 641, 673, 681, 602, 743	71-B657-XX-XX	525	71-B710-XX-XX	397	71-E122-XX-XX	408, 495, 503, 545, 552, 571, 575, 591, 593, 595, 689, 635, 641, 652, 655, 657, 661, 665, 667, 673, 676, 625, 603, 609, 741, 822, 825, 901, 903
71-B642-XX-XX	503, 512, 525, 546, 570, 591, 688, 634, 641, 602, 743	71-B658-XX-XX	154, 158, 161, 164, 167, 170	71-E002-XX-XX	769, 771		
71-B643-XX-XX	503, 512, 525, 546, 591, 634, 641, 602, 743			71-E004-XX-XX	419, 495, 507, 689		
71-B644-XX-XX	494, 503, 512, 570, 688, 634, 673, 676, 681, 602, 743	71-B659-XX-XX	154, 158, 161, 164, 167, 170	71-E005-XX-XX	419, 495, 507, 689	71-E119-XX-XX	729, 775, 777, 779
71-B645-XX-XX	503, 512, 525, 546, 570, 688, 634, 673, 681, 602, 743	71-B660-XX-XX	593	71-E006-XX-XX	757, 758		
71-B646-XX-XX	503, 512, 525, 546, 570, 688, 634, 673, 681, 602, 743	71-B661-XX-XX	593	71-E009-XX-XX	768	71-E118-XX-XX	503
71-B647-XX-XX	494, 503, 512, 525, 546, 688, 634, 602, 743	71-B662-XX-XX	593	71-E012-XX-XX	717	71-E122-XX-XX	408, 495, 503, 545, 552, 571, 575, 591, 593, 595, 689, 635, 641, 652, 655, 657, 661, 665, 667, 673, 676, 625, 603, 609, 741, 822, 825, 901, 903
		71-B663-XX-XX	591, 593, 641, 724	71-E013-XX-XX	759		
		71-B664-XX-XX	591, 593, 641	71-E014-XX-XX	546, 581, 697, 634, 602, 743	71-E131-XX-XX	544, 548, 635, 603, 742, 793, 855
		71-B675-XX-XX	494, 503, 512, 525, 546, 570, 634, 602, 743	71-E015-XX-XX	697	71-E133-XX-XX	544, 548, 635, 603, 742, 793, 855
		71-B676-XX-XX	595	71-E016-XX-XX	564, 565, 567, 583		
		71-B677-XX-XX	595, 661	71-E018-XX-XX	773	71-E135-XX-XX	544, 548, 635, 603, 742, 793, 855
		71-B678-XX-XX	593	71-E028-XX-XX	772		
		71-B681-XX-XX	246, 305, 308, 409	71-E029-XX-XX	765	71-E139-XX-XX	591, 635, 641
		71-B682-XX-XX	546, 634, 623, 602, 743	71-E030-XX-XX	766		
		71-B683-XX-XX	165	71-E034-XX-XX	419, 495, 507, 689	71-E141-XX-XX	544, 548, 635, 603, 742, 793, 855
		71-B684-XX-XX	165	71-E036-XX-XX	606		
		71-B685-XX-XX	165, 171	71-E037-XX-XX	492	71-E143-XX-XX	545, 571
		71-B686-XX-XX	165, 171	71-E038-XX-XX	492	71-E145-XX-XX	548, 742
				71-E043-XX-XX	491		
				71-E047-XX-XX	491		
				71-E052-XX-XX	537, 564, 565, 575, 581, 583		
				71-E058-XX-XX	564		
				71-E065-XX-XX	408, 623		
				71-E071-XX-XX	419, 495, 507, 689		
				71-E078-XX-XX	807		
				71-E079-XX-XX	546, 634, 602, 743		

References Index / Index des références

Reference Référence	Page Page.	Reference Référence	Page Page.	Reference Référence	Page Page.	Reference Référence	Page Page.
71-E163-XX-XX	492	71-E390-XX-XX	527	71-E512-XX-XX	408, 495, 545, 552, 571, 575, 581, 591, 593, 595, 689, 635, 641, 652, 655, 657, 661, 665, 667, 673, 676, 603, 609, 741, 822	71-E618-XX-XX	494
71-E213-XX-XX	777	71-E404-XX-XX	408			71-E627-XX-XX	591, 641
71-E216-XX-XX	537	71-E417-XX-XX	548, 742			71-E628-XX-XX	591, 641
71-E217-XX-XX	537	71-E418-XX-XX	591, 635, 641			71-E629-XX-XX	591, 641
71-E218-XX-XX	537	71-E419-XX-XX	544, 548, 635, 603, 742			71-E633-XX-XX	548
71-E225-XX-XX	581					71-E634-XX-XX	552, 609, 746, 797, 857
71-E226-XX-XX	581	71-E420-XX-XX	544, 548, 635, 603, 742	71-E513-XX-XX	408, 495, 545, 552, 571, 575, 591, 593, 595, 689, 635, 641, 652, 655, 657, 661, 665, 667, 673, 676, 603, 609, 741, 822	71-E635-XX-XX	746
71-E234-XX-XX	557, 711, 713, 786, 866					71-E636-XX-XX	723, 724, 733
71-E235-XX-XX	557, 786, 866	71-E421-XX-XX	544, 548, 635, 603, 742			71-E638-XX-XX	489
71-E243-XX-XX	492					71-E639-XX-XX	489
71-E244-XX-XX	492	71-E422-XX-XX	544, 548, 635, 603, 742			71-E640-XX-XX	494
71-E245-XX-XX	492					71-E641-XX-XX	494
71-E259-XX-XX	548, 742	71-E427-XX-XX	526, 538, 920			71-E642-XX-XX	489
71-E260-XX-XX	544, 548, 635, 603, 742, 793, 855	71-E428-XX-XX	526, 538, 539, 563, 582			71-E647-XX-XX	489
71-E261-XX-XX	544, 548, 635, 603, 742, 793, 855			71-E518-XX-XX	581	71-E648-XX-XX	489
71-E262-XX-XX	544, 548, 635, 603, 742, 793, 855	71-E429-XX-XX	526, 538, 539, 563	71-E547-XX-XX	526, 538, 539, 563, 582	71-E649-XX-XX	883
71-E263-XX-XX	544, 548, 635, 603, 742, 793, 855	71-E430-XX-XX	526, 538, 539			71-E650-XX-XX	883
71-E264-XX-XX	591, 635, 641	71-E437-XX-XX	526, 538, 920	71-E548-XX-XX	526, 538, 539, 563	71-E651-XX-XX	883
71-E278-XX-XX	825, 903	71-E438-XX-XX	526, 538, 539, 563, 582	71-E549-XX-XX	526, 538, 539	71-E652-XX-XX	883
71-E279-XX-XX	825, 897, 899, 902, 903	71-E440-XX-XX	526, 538, 539, 563	71-E552-XX-XX	526, 538, 920	71-E653-XX-XX	883
71-E280-XX-XX	897, 899, 902	71-E441-XX-XX	526, 538, 539	71-E557-XX-XX	526, 538, 920	71-E654-XX-XX	883
71-E281-XX-XX	897, 899, 902	71-E458-XX-XX	888	71-E559-XX-XX	489	71-E655-XX-XX	883
71-E282-XX-XX	897, 899, 902	71-E462-XX-XX	544, 548, 635, 603, 742	71-E572-XX-XX	489	71-E656-XX-XX	883
71-E284-XX-XX	825, 897, 899, 901, 903	71-E463-XX-XX	544, 548, 635, 603, 742, 793, 855	71-E573-XX-XX	489	71-E657-XX-XX	883
71-E292-XX-XX	897, 899			71-E574-XX-XX	489	71-E663-XX-XX	495
71-E293-XX-XX	888, 897	71-E464-XX-XX	544, 548, 635, 603, 742, 793, 855	71-E575-XX-XX	489	71-E676-XX-XX	489
71-E294-XX-XX	897	71-E467-XX-XX	603	71-E577-XX-XX	490	71-E677-XX-XX	489
71-E357-XX-XX	897, 899	71-E489-XX-XX	402, 614	71-E578-XX-XX	490	71-E678-XX-XX	490
71-E358-XX-XX	897, 899	71-E510-XX-XX	408, 495, 545, 571, 581, 689, 635, 661, 673, 676, 603, 741	71-E579-XX-XX	490	71-E679-XX-XX	490
71-E359-XX-XX	490			71-E580-XX-XX	490	71-E680-XX-XX	490
71-E360-XX-XX	490			71-E582-XX-XX	490	71-E681-XX-XX	490
71-E361-XX-XX	655, 657, 825, 901, 903			71-E583-XX-XX	490	71-E682-XX-XX	491
71-E363-XX-XX	711			71-E584-XX-XX	490	71-E683-XX-XX	491
71-E367-XX-XX	888, 897			71-E585-XX-XX	490	71-E684-XX-XX	544
71-E389-XX-XX	527			71-E586-XX-XX	491	71-E685-XX-XX	544
				71-E587-XX-XX	491	71-E686-XX-XX	544
				71-E605-XX-XX	548, 742	71-E687-XX-XX	544
				71-E606-XX-XX	548, 742	71-E688-XX-XX	544
				71-E607-XX-XX	548, 742	71-E689-XX-XX	544
				71-E608-XX-XX	713	81-3239-XX-XX	775
				71-E610-XX-XX	920	81-9914-XX-XX	729
				71-E611-XX-XX	920	81-9915-XX-XX	729
				71-E614-XX-XX	494	81-E000-XX-XX	777
				71-E615-XX-XX	494	81-E102-XX-XX	779
				71-E616-XX-XX	494	81-E103-XX-XX	779
				71-E617-XX-XX	494	90-1720-XX-XX	231
						90-1722-XX-XX	231
						90-2889-XX-XX	962
						90-2899-XX-XX	182
						90-2902-XX-XX	231

References Index / Index des références

Reference Référence	Page Page.	Reference Référence	Page Page.	Reference Référence	Page Page.	Reference Référence	Page Page.
90-2903-XX-XX	231	90-6368-XX-XX	235, 959	90-6699-XX-XX	237	90-8007-XX-XX	304
90-3208-XX-XX	284	90-6369-XX-XX	235, 959	90-7002-XX-XX	238	90-8008-XX-XX	304
90-3209-XX-XX	284	90-6370-XX-XX	235, 960	90-7005-XX-XX	238	90-8009-XX-XX	304
90-3210-XX-XX	284	90-6371-XX-XX	235, 960	90-7006-XX-XX	238	90-8010-XX-XX	304
90-3211-XX-XX	284	90-6372-XX-XX	235, 960	90-7098-XX-XX	240	90-8011-XX-XX	304
90-3529-XX-XX	284	90-6373-XX-XX	235, 960	90-7099-XX-XX	240	90-8012-XX-XX	304
90-3530-XX-XX	284	90-6374-XX-XX	235, 960	90-7100-XX-XX	240	90-8013-XX-XX	302
90-3925-XX-XX	182	90-6375-XX-XX	235, 960	90-7101-XX-XX	240	90-8014-XX-XX	302
90-3926-XX-XX	182	90-6376-XX-XX	236	90-7161-XX-XX	240	90-8035-XX-XX	315
90-3927-XX-XX	183	90-6377-XX-XX	236	90-7169-XX-XX	240	90-8036-XX-XX	315
90-3928-XX-XX	183	90-6378-XX-XX	236	90-7184-XX-XX	240	90-8037-XX-XX	315
90-3929-XX-XX	183	90-6379-XX-XX	236	90-7185-XX-XX	240	90-8038-XX-XX	315
90-3930-XX-XX	183	90-6380-XX-XX	236	90-7186-XX-XX	240	90-8078-XX-XX	226
90-4880-XX-XX	182, 962	90-6381-XX-XX	236	90-7187-XX-XX	240	90-8079-XX-XX	226
90-4881-XX-XX	182, 962	90-6382-XX-XX	237	90-7188-XX-XX	240	90-8080-XX-XX	226
90-4883-XX-XX	182, 963	90-6383-XX-XX	237	90-7189-XX-XX	240	90-A003-XX-XX	302
90-4885-XX-XX	183, 963	90-6384-XX-XX	237	90-7190-XX-XX	240	90-A004-XX-XX	302
90-4886-XX-XX	183, 963	90-6385-XX-XX	237	90-7191-XX-XX	240	90-A005-XX-XX	302
90-6161-XX-XX	235	90-6386-XX-XX	237	90-7192-XX-XX	240	90-A009-XX-XX	304
90-6162-XX-XX	235	90-6387-XX-XX	237	90-7193-XX-XX	240	90-A010-XX-XX	304
90-6163-XX-XX	235	90-6388-XX-XX	237	90-7194-XX-XX	240	90-A011-XX-XX	304
90-6164-XX-XX	235	90-6389-XX-XX	237	90-7195-XX-XX	240	90-A019-XX-XX	304
90-6165-XX-XX	235	90-6390-XX-XX	237	90-7214-XX-XX	242	90-A021-XX-XX	302
90-6166-XX-XX	235	90-6391-XX-XX	237	90-7215-XX-XX	242	90-A026-XX-XX	226
90-6167-XX-XX	236	90-6392-XX-XX	237	90-7216-XX-XX	242	90-A027-XX-XX	226
90-6168-XX-XX	236	90-6393-XX-XX	237	90-7217-XX-XX	242	90-A028-XX-XX	226
90-6169-XX-XX	236	90-6673-XX-XX	235, 960	90-7218-XX-XX	242	90-A029-XX-XX	226
90-6170-XX-XX	236	90-6674-XX-XX	235, 960	90-7219-XX-XX	242	90-A030-XX-XX	226
90-6171-XX-XX	236	90-6675-XX-XX	235, 960	90-7220-XX-XX	242	90-A031-XX-XX	226
90-6172-XX-XX	236	90-6676-XX-XX	235	90-7221-XX-XX	242	90-A032-XX-XX	181, 964
90-6173-XX-XX	236	90-6677-XX-XX	235	90-7222-XX-XX	242	90-A033-XX-XX	181, 964
90-6174-XX-XX	236	90-6678-XX-XX	235	90-7223-XX-XX	242	90-A034-XX-XX	181, 964
90-6175-XX-XX	236	90-6679-XX-XX	235, 960	90-7224-XX-XX	242	90-A035-XX-XX	181, 965
90-6349-XX-XX	236	90-6680-XX-XX	235, 960	90-7225-XX-XX	242	90-A036-XX-XX	181, 965
90-6350-XX-XX	236	90-6681-XX-XX	235, 960	90-7226-XX-XX	242	90-A037-XX-XX	181, 965
90-6351-XX-XX	236	90-6682-XX-XX	236	90-7227-XX-XX	242	90-A038-XX-XX	302
90-6352-XX-XX	237	90-6683-XX-XX	236	90-7228-XX-XX	242	90-A039-XX-XX	302
90-6353-XX-XX	237	90-6684-XX-XX	236	90-7229-XX-XX	242	90-A040-XX-XX	304
90-6354-XX-XX	237	90-6685-XX-XX	236	90-7230-XX-XX	242	90-A041-XX-XX	304
90-6355-XX-XX	237	90-6686-XX-XX	236	90-7231-XX-XX	242	90-A045-XX-XX	253
90-6356-XX-XX	237	90-6687-XX-XX	236	90-7273-XX-XX	302	90-A046-XX-XX	253
90-6357-XX-XX	237	90-6688-XX-XX	236	90-7274-XX-XX	302	90-A047-XX-XX	253
90-6358-XX-XX	238	90-6689-XX-XX	236	90-7275-XX-XX	302	90-A048-XX-XX	253
90-6359-XX-XX	238	90-6690-XX-XX	236	90-7276-XX-XX	302	90-A049-XX-XX	253
90-6360-XX-XX	238	90-6691-XX-XX	237	90-7277-XX-XX	302	90-A050-XX-XX	253
90-6361-XX-XX	238	90-6692-XX-XX	237	90-7278-XX-XX	302	90-A051-XX-XX	253
90-6362-XX-XX	238	90-6693-XX-XX	237	90-7359-XX-XX	150	90-A052-XX-XX	253
90-6363-XX-XX	238	90-6694-XX-XX	237	90-7360-XX-XX	150	90-A053-XX-XX	253
90-6364-XX-XX	235, 959	90-6695-XX-XX	237	90-7361-XX-XX	150	90-A054-XX-XX	253
90-6365-XX-XX	235, 959	90-6696-XX-XX	237	90-7362-XX-XX	150	90-A055-XX-XX	253
90-6366-XX-XX	235, 959	90-6697-XX-XX	237	90-7804-XX-XX	238	90-A056-XX-XX	253
90-6367-XX-XX	235, 959	90-6698-XX-XX	237	90-7805-XX-XX	238	90-A057-XX-XX	253

References Index / Index des références

Reference Référence	Page Page.	Reference Référence	Page Page.	Reference Référence	Page Page.	Reference Référence	Page Page.
90-A058-XX-XX	253	90-A153-XX-XX	303	90-A209-XX-XX	228	91-A016-XX-XX	427
90-A059-XX-XX	253	90-A154-XX-XX	303	90-A210-XX-XX	228	91-A017-XX-XX	429
90-A060-XX-XX	303	90-A155-XX-XX	303	90-A211-XX-XX	228	91-A019-XX-XX	429
90-A061-XX-XX	303	90-A156-XX-XX	303	90-A212-XX-XX	228	91-A020-XX-XX	429
90-A062-XX-XX	303	90-A157-XX-XX	303	91-2379-XX-XX	426	91-A021-XX-XX	429
90-A063-XX-XX	151	90-A158-XX-XX	303	91-3282-XX-XX	424	91-A024-XX-XX	430
90-A064-XX-XX	151	90-A159-XX-XX	303	91-5567-XX-XX	427	91-A025-XX-XX	430
90-A065-XX-XX	151	90-A160-XX-XX	303	91-5571-XX-XX	428	91-A026-XX-XX	431
90-A066-XX-XX	151	90-A161-XX-XX	304	91-5572-XX-XX	428	91-A027-XX-XX	149
90-A088-XX-XX	253	90-A162-XX-XX	304	91-5573-XX-XX	428	91-A028-XX-XX	149
90-A089-XX-XX	253	90-A163-XX-XX	304	91-7908-XX-XX	424	91-A029-XX-XX	149
90-A090-XX-XX	253	90-A164-XX-XX	304	91-7909-XX-XX	424	91-A030-XX-XX	149
90-A091-XX-XX	253	90-A165-XX-XX	304	91-7910-XX-XX	424	91-A031-XX-XX	149
90-A092-XX-XX	253	90-A166-XX-XX	304	91-7911-XX-XX	424	91-A032-XX-XX	149
90-A093-XX-XX	253	90-A167-XX-XX	304	91-7912-XX-XX	424	91-A033-XX-XX	149
90-A094-XX-XX	254	90-A168-XX-XX	304	91-7913-XX-XX	424	91-A034-XX-XX	149
90-A095-XX-XX	254	90-A169-XX-XX	304	91-7914-XX-XX	424	91-A035-XX-XX	418, 506
90-A096-XX-XX	254	90-A174-XX-XX	226	91-7915-XX-XX	424	91-A036-XX-XX	418, 506
90-A097-XX-XX	254	90-A175-XX-XX	226	91-7916-XX-XX	424	91-A038-XX-XX	418, 506
90-A098-XX-XX	254	90-A176-XX-XX	226	91-7917-XX-XX	424	91-A039-XX-XX	418, 506
90-A099-XX-XX	254	90-A177-XX-XX	226	91-7918-XX-XX	424	ACT-9165-XX-XX	103
90-A100-XX-XX	254	90-A178-XX-XX	226	91-7919-XX-XX	424	AG11-XXXXXXXXXX	202, 943
90-A101-XX-XX	254	90-A179-XX-XX	226	91-7920-XX-XX	424	AG12-XXXXXXXXXX	202, 943
90-A102-XX-XX	254	90-A180-XX-XX	226	91-7921-XX-XX	425	AG13-XXXXXXXXXX	205, 944
90-A103-XX-XX	254	90-A181-XX-XX	226	91-7922-XX-XX	425	AG14-XXXXXXXXXX	205, 944
90-A104-XX-XX	254	90-A182-XX-XX	226	91-7923-XX-XX	425	AG15-XXXXXXXXXX	204, 944
90-A105-XX-XX	254	90-A183-XX-XX	227	91-7924-XX-XX	425	AG16-XXXXXXXXXX	206, 945
90-A106-XX-XX	254	90-A184-XX-XX	227	91-7925-XX-XX	425	AG17-XXXXXXXXXX	204, 944
90-A107-XX-XX	254	90-A185-XX-XX	227	91-7926-XX-XX	426	AG19-XXXXXXXXXX	202, 943
90-A108-XX-XX	254	90-A186-XX-XX	227	91-7927-XX-XX	426	AG21-XXXXXXXXXX	202, 943
90-A109-XX-XX	254	90-A187-XX-XX	227	91-7928-XX-XX	427	AG22-XXXXXXXXXX	206, 945
90-A110-XX-XX	254	90-A188-XX-XX	227	91-7929-XX-XX	427	AG23-XXXXXXXXXX	214, 950
90-A111-XX-XX	254	90-A189-XX-XX	227	91-7930-XX-XX	429	AG24-XXXXXXXXXX	215, 950
90-A112-XX-XX	245	90-A190-XX-XX	227	91-7931-XX-XX	429	AG25-XXXXXXXXXX	216, 951
90-A113-XX-XX	245	90-A191-XX-XX	227	91-7934-XX-XX	430	AG26-XXXXXXXXXX	217, 951
90-A114-XX-XX	245	90-A192-XX-XX	227	91-7935-XX-XX	430	AG27-XXXXXXXXXX	214, 950
90-A115-XX-XX	245	90-A193-XX-XX	227	91-7936-XX-XX	430	AG28-XXXXXXXXXX	215, 950
90-A116-XX-XX	245	90-A194-XX-XX	227	91-7937-XX-XX	430	AG29-XXXXXXXXXX	216, 951
90-A117-XX-XX	245	90-A195-XX-XX	227	91-7938-XX-XX	430	AG31-XXXXXXXXXX	217, 951
90-A118-XX-XX	245	90-A196-XX-XX	227	91-7939-XX-XX	430	AG32-XXXXXXXXXX	283
90-A119-XX-XX	245	90-A197-XX-XX	227	91-7940-XX-XX	431	AG33-XXXXXXXXXX	203
90-A120-XX-XX	245	90-A198-XX-XX	227	91-7941-XX-XX	431	AG34-XXXXXXXXXX	203
90-A121-XX-XX	245	90-A199-XX-XX	227	91-A000-XX-XX	418, 506	AG36-XXXXXXXXXX	205
90-A122-XX-XX	245	90-A200-XX-XX	227	91-A001-XX-XX	418, 506	AG37-XXXXXXXXXX	206
90-A123-XX-XX	245	90-A201-XX-XX	228	91-A002-XX-XX	418, 506	AG38-XXXXXXXXXX	203
90-A124-XX-XX	246	90-A202-XX-XX	228	91-A003-XX-XX	418, 506	AG39-XXXXXXXXXX	203
90-A125-XX-XX	246	90-A203-XX-XX	228	91-A004-XX-XX	418, 506	AG41-XXXXXXXXXX	205
90-A126-XX-XX	246	90-A204-XX-XX	228	91-A005-XX-XX	418, 506	AG42-XXXXXXXXXX	218
90-A127-XX-XX	246	90-A205-XX-XX	228	91-A012-XX-XX	424	AG43-XXXXXXXXXX	207, 945
90-A128-XX-XX	246	90-A206-XX-XX	228	91-A013-XX-XX	426	AG44-XXXXXXXXXX	207, 945
90-A129-XX-XX	246	90-A207-XX-XX	228	91-A014-XX-XX	427	AG45-XXXXXXXXXX	208, 946
90-A152-XX-XX	303	90-A208-XX-XX	228	91-A015-XX-XX	427	AG46-XXXXXXXXXX	208, 946

References Index / Index des références

Reference Référence	Page Page.	Reference Référence	Page Page.	Reference Référence	Page Page.	Reference Référence	Page Page.
AG47-XXXXXXXXXX	208, 946	AK18-XXXXXXXXXX	351, 353, 355, 357, 954, 955	AT19-XXXXXXXXXX	791	AW59-XXXXXXXXXX	330
AG48-XXXXXXXXXX	208, 946			AT21-XXXXXXXXXX	793	AW61-XXXXXXXXXX	330
AG52-XXXXXXXXXX	210, 947	AK19-XXXXXXXXXX	351, 353, 355, 357, 954, 955	AT22-XXXXXXXXXX	854	AZ11-XXXXXXXXXX	649
AG53-XXXXXXXXXX	210, 947			AT26-XXXXXXXXXX	547	AZ13-XXXXXXXXXX	649
AG55-XXXXXXXXXX	210, 947	AK21-XXXXXXXXXX	351, 353, 355, 357, 954, 955	AU11-XXXXXXXXXX	248	AZ14-XXXXXXXXXX	649
AG56-XXXXXXXXXX	211, 948			AU12-XXXXXXXXXX	248	AZ15-XXXXXXXXXX	650
AG57-XXXXXXXXXX	211, 948	AK23-XXXXXXXXXX	351, 353, 355, 357, 363, 954, 955	AU13-XXXXXXXXXX	249	AZ16-XXXXXXXXXX	650
AG58-XXXXXXXXXX	212, 949			AU14-XXXXXXXXXX	249	AZ17-XXXXXXXXXX	650
AG59-XXXXXXXXXX	213, 948	AK24-XXXXXXXXXX	352, 354, 356, 358, 359, 360, 361, 362, 363	AU15-XXXXXXXXXX	286	AZ18-XXXXXXXXXX	651
AG61-XXXXXXXXXX	209			AU16-XXXXXXXXXX	286	AZ19-XXXXXXXXXX	651
AG62-XXXXXXXXXX	209	AK25-XXXXXXXXXX	352, 354, 356, 358	AU17-XXXXXXXXXX	248	AZ21-XXXXXXXXXX	652
AG64-XXXXXXXXXX	210	AL11-XXXXXXXXXX	696	AU18-XXXXXXXXXX	248	BA11-XXXXXXXXXX	632
AG65-XXXXXXXXXX	211	AL12-XXXXXXXXXX	696	AU19-XXXXXXXXXX	249	BA12-XXXXXXXXXX	632
AG66-XXXXXXXXXX	212	AN11-XXXXXXXXXX	535	AU21-XXXXXXXXXX	249	BA13-XXXXXXXXXX	632
AG67-XXXXXXXXXX	213	AN12-XXXXXXXXXX	535	AU22-XXXXXXXXXX	287	BA14-XXXXXXXXXX	600
AG68-XXXXXXXXXX	271	AN13-XXXXXXXXXX	536	AU23-XXXXXXXXXX	287	BA15-XXXXXXXXXX	600
AG69-XXXXXXXXXX	283	AN14-XXXXXXXXXX	536	AV11-XXXXXXXXXX	277	BA16-XXXXXXXXXX	600
AG71-XXXXXXXXXX	96	AP51-XXXXXXXXXX	258	AV12-XXXXXXXXXX	277	BA17-XXXXXXXXXX	740
AI11-XXXXXXXXXX	632	AP52-XXXXXXXXXX	258	AV13-XXXXXXXXXX	277	BA18-XXXXXXXXXX	542
AI12-XXXXXXXXXX	632	AQ11-XXXXXXXXXX	259, 966	AV14-XXXXXXXXXX	270	BA26-XXXXXXXXXX	547
AI13-XXXXXXXXXX	632	AQ12-XXXXXXXXXX	259, 966	AV15-XXXXXXXXXX	270	BB11-XXXXXXXXXX	373
AI14-XXXXXXXXXX	600	AQ13-XXXXXXXXXX	259, 966	AV16-XXXXXXXXXX	270	BB12-XXXXXXXXXX	373
AI15-XXXXXXXXXX	600	AQ14-XXXXXXXXXX	259, 966	AV17-XXXXXXXXXX	276	BB13-XXXXXXXXXX	374
AI16-XXXXXXXXXX	600	AR11-XXXXXXXXXX	281	AV19-XXXXXXXXXX	144	BB14-XXXXXXXXXX	374
AI17-XXXXXXXXXX	740	AR12-XXXXXXXXXX	281	AV21-XXXXXXXXXX	87	BB15-XXXXXXXXXX	374
AI18-XXXXXXXXXX	542	AR13-XXXXXXXXXX	281	AV23-XXXXXXXXXX	144	BB16-XXXXXXXXXX	374
AI19-XXXXXXXXXX	791	AR14-XXXXXXXXXX	281	AV24-XXXXXXXXXX	144	BB19-XXXXXXXXXX	372
AI21-XXXXXXXXXX	792	AR21-XXXXXXXXXX	267	AV25-XXXXXXXXXX	87	BB21-XXXXXXXXXX	372
AI22-XXXXXXXXXX	854	AR22-XXXXXXXXXX	267	AV26-XXXXXXXXXX	270	BB22-XXXXXXXXXX	373
AI23-XXXXXXXXXX	791	AR23-XXXXXXXXXX	267	AV27-XXXXXXXXXX	276	BB23-XXXXXXXXXX	373
AI24-XXXXXXXXXX	792	AR24-XXXXXXXXXX	267	AV28-XXXXXXXXXX	277	BB24-XXXXXXXXXX	375
AI25-XXXXXXXXXX	854	AS11-XXXXXXXXXX	556, 713, 785, 865	AW14-XXXXXXXXXX	328	BB25-XXXXXXXXXX	375
AI26-XXXXXXXXXX	547	AS12-XXXXXXXXXX	556, 785, 865	AW15-XXXXXXXXXX	328	BB26-XXXXXXXXXX	373, 374
AK11-XXXXXXXXXX	351, 353, 355, 357	AS13-XXXXXXXXXX	556, 785, 865	AW16-XXXXXXXXXX	328	BB27-XXXXXXXXXX	373, 374
AK12-XXXXXXXXXX	351, 353, 355, 357	AS14-XXXXXXXXXX	711	AW18-XXXXXXXXXX	334	BB28-XXXXXXXXXX	375
AK13-XXXXXXXXXX	351, 353, 355, 357	AS15-XXXXXXXXXX	711	AW21-XXXXXXXXXX	334	BB29-XXXXXXXXXX	375
AK14-XXXXXXXXXX	351, 353, 355, 357, 359, 360, 361, 362, 363, 954, 955	AS16-XXXXXXXXXX	712	AW25-XXXXXXXXXX	332	BB31-XXXXXXXXXX	373
AK15-XXXXXXXXXX	351, 353, 355, 357, 359, 360, 361, 362, 363, 954, 955	AT11-XXXXXXXXXX	633	AW26-XXXXXXXXXX	332	BB32-XXXXXXXXXX	374
		AT12-XXXXXXXXXX	633	AW27-XXXXXXXXXX	332	BB33-XXXXXXXXXX	372
		AT13-XXXXXXXXXX	633	AW29-XXXXXXXXXX	333	BB34-XXXXXXXXXX	374
		AT14-XXXXXXXXXX	601	AW32-XXXXXXXXXX	333	BB35-XXXXXXXXXX	372
		AT15-XXXXXXXXXX	601	AW34-XXXXXXXXXX	335	BD11-XXXXXXXXXX	524
		AT16-XXXXXXXXXX	601	AW36-XXXXXXXXXX	335	BD12-XXXXXXXXXX	525
		AT17-XXXXXXXXXX	741	AW38-XXXXXXXXXX	337	BD13-XXXXXXXXXX	524
		AT18-XXXXXXXXXX	543	AW41-XXXXXXXXXX	336	BD14-XXXXXXXXXX	525
				AW45-XXXXXXXXXX	329	BD15-XXXXXXXXXX	524
				AW46-XXXXXXXXXX	329	BD16-XXXXXXXXXX	525
				AW47-XXXXXXXXXX	329	BD17-XXXXXXXXXX	524
				AW52-XXXXXXXXXX	331	BD18-XXXXXXXXXX	525
				AW53-XXXXXXXXXX	331	BH11-XXXXXXXXXX	177
				AW54-XXXXXXXXXX	331	BH12-XXXXXXXXXX	177
				AW58-XXXXXXXXXX	330		

References Index / Index des références

Reference Référence	Page Page.	Reference Référence	Page Page.	Reference Référence	Page Page.
BH13-XXXXXXXXXX	177	EM02-0100PA1400	936	EM08-0203NA6001	940
BH14-XXXXXXXXXX	177	EM02-0100PN1400	936	EM10-0103NN1400	939
BI11-XXXXXXXXXX	493	EM02-0103NN1400	936	EM10-0103NN1401	939
BI12-XXXXXXXXXX	493	EM02-0103PN1400	936	EM10-0103PN1400	939
BI13-XXXXXXXXXX	493	EM02-0150NN1400	936	EM10-0103PN1401	939
BJ11-XXXXXXXXXX	592	EM02-0200NA1400	936	EM10-0203NN1400	939
BJ12-XXXXXXXXXX	592	EM02-0200NN1400	936	EM10-0203NN1401	939
BJ13-XXXXXXXXXX	592	EM02-0200PA1400	936	EM10-0203PN1400	939
BJ14-XXXXXXXXXX	590, 640	EM02-0200PN1400	936	EM10-0203PN1401	939
BJ15-XXXXXXXXXX	590, 640	EM02-0203NN1400	936	EM10-0303NA1400	939
BJ16-XXXXXXXXXX	590, 640	EM02-0203PN1400	936	EM10-0303NN1400	939
DN-1600-XX-XX	229	EM02-0300NA1400	936	EM10-0303NN1401	939
DN-1601-XX-XX	229	EM02-0300NA1401	936	EM10-0303PA1400	939
EM01-0001	937	EM02-0300NN1400	936	EM10-0303PN1400	939
EM01-0002	937	EM02-0300PA1400	936	EM10-0303PN1401	939
EM01-0003	937	EM02-0300PA1401	936		
EM01-0005	937	EM02-0300PN1400	936		
EM01-0006	937	EM02-0303NA1400	936		
EM01-0007	937	EM02-0303NA1401	936		
EM01-0008	937	EM02-0303NN1400	936		
EM01-0060NN1400	935	EM02-0303PA1400	936		
EM01-0100NA1400	935	EM02-0303PA1401	936		
EM01-0100NN1400	935	EM02-0303PN1400	936		
EM01-0100PA1400	935	EM02-0500NN1400	936		
EM01-0100PN1400	935	EM02-0500PN1400	936		
EM01-0103NN1400	935	EM03-0103PA1400	938		
EM01-0103PN1400	935	EM04-0001	932		
EM01-0150NN1400	935	EM04-0002	932		
EM01-0200NA1400	935	EM04-0003	932		
EM01-0200NN1400	935	EM04-0200PA1400	932		
EM01-0200PA1400	935	EM04-0200PA1401	932		
EM01-0200PN1400	935	EM04-0200PA6000	932		
EM01-0203NN1400	935	EM04-0200PA6001	932		
EM01-0203PN1400	935	EM04-0200PN1400	932		
EM01-0300NA1400	935	EM04-0200PN6000	932		
EM01-0300NA1401	935	EM04-0203PA1400	932		
EM01-0300NN1400	935	EM04-0203PA1401	932		
EM01-0300PA1400	935	EM04-0203PA6000	932		
EM01-0300PA1401	935	EM04-0203PA6001	932		
EM01-0300PN1400	935	EM04-0203PN1400	932		
EM01-0303NA1400	935	EM04-0203PN6000	932		
EM01-0303NA1401	935	EM05-0203PA1400	932		
EM01-0303NN1400	935	EM05-0203PA1401	932		
EM01-0303PA1400	935	EM05-0203PA6000	932		
EM01-0303PA1401	935	EM05-0203PA6001	932		
EM01-0303PN1400	935	EM05-0203PN1400	932		
EM01-0500NN1400	935	EM05-0203PN6000	932		
EM01-0500PN1400	935	EM06-0006NN1400	938		
EM02-0004	937				
EM02-0060NN1400	936	EM08-0203NA1400	940		
EM02-0100NA1400	936	EM08-0203NA1401	940		
EM02-0100NN1400	936	EM08-0203NA6000	940		

Important information

Informations importantes

To complete your project, please consult our Decorative Collection 2024/2025 catalogue.
For specific Retail, Office or Architectural Systems projects, please consult our 2024 catalogues.
For special projects and customised products, please contact our sales team.

Pour compléter votre projet, veuillez consulter notre catalogue Collection décorative 2024/2025.
Pour des projets spécifiques de vente au détail, de bureaux ou de systèmes architecturaux, veuillez consulter nos catalogues 2024.
Pour les projets spéciaux et les produits personnalisés, veuillez contacter notre équipe de vente.



LedsC4 Catalogues
Catalogues LedsC4

Due to the constant technological developments in LED technology, product technical data may vary over time. We recommend you consult the technical data sheet for each product on our website (ledsc4.com) to read more about the latest version.

En raison de l'évolution constante de la technologie LED, les données techniques des produits peuvent varier dans le temps. Nous recommandons de consulter la fiche technique disponible sur le site Internet (ledsc4.com) pour disposer d'une version à jour.

Credits

Crédits

Art direction
Direction artistique
Mucho

Graphic Design
Design Graphique
Sicart Studio

Interactivity
Interactivité
Roger Alemany

Photography
Photographie
Jordi Anguera
Enric Badrinas
Isabel Casanova
Maria Dias
Leo García
Salva López
Javier Márquez
Marta Vidal
Laura Pardo
Jordi Solé
Marçal Vaquer
Biel Aliño
German Borrelli

Typography
Typographie
Gliko Modern
Maison Neue
Blacker Pro Modern

Edition
Édition
December 2023
Copyright © LedsC4 2023
All rights reserved

LedsC4
Afores s/n 25750 Torà
Lleida – Spain
+34 973 468 100
ledsc4@ledsc4.com

Customer Service

Spain

+34 973 468 101
spain@ledsc4.com

Europe

+34 973 468 102
europe@ledsc4.com

Latin America

+34 973 468 115
sudamerica@ledsc4.com

LedsC4 Centro Innovación Madrid

Pol. Industrial Ventorro del Cano
Calle Cercedilla 11 Nave1
28925 Alcorcón, Madrid

Colombia

601+3441723

Poland

Leds Polska Sp. z o.o.
Ul. Kasztanowa 44
05-816 Michalowice-Wies POLAND
+48 71 733 64 01
biuro@ledsc4.pl

United Kingdom

Free phone: 0808 234 2641
uk@ledsc4.com

Italy

Toll-free: 800 784 275
italia@ledsc4.com

Asia Pacific

+34 973 468 116
asiapacific@ledsc4.com

Canada

Toll-free: +1-866-5636666
CustomerServiceUS@ledsc4.com

Germany

ImWissenschaftspark
Deutschland GmbH
Munscheidstraße 14
45886 Gelsenkirchen GERMANY
+49 209 882 99 021
deutschland@ledsc4.com

Asia Pacific

8 Robinson Road
#03-00 ASO Building
048544 SINGAPORE
+34 973468116

France

+34 973 468 130
france@ledsc4.com

Portugal

+34 973 468 102
portugal@ledsc4.com

Africa

+34 973 468 116
africa@ledsc4.com

United States

Toll-free: +1-888-3710243
CustomerServiceUS@ledsc4.com

Middle East

Fortune Executive Tower
Cluster T - Office 204
Jumeirah Lake Towers
PO 336910 Dubai - UAE
+971 4458 4272

South Africa

Office 111, Regus Business Centre
(AMR Building)
3 Concorde Road East
2007 Bedfordview SOUTH AFRICA
+27100075231
SouthAfrica@ledsc4.com

Press

comunicacion@ledsc4.com

Suppliers

+ 34 973 468 113

Ledsc4.com



 Instagram: [instagram.com/leds_c4/](https://www.instagram.com/leds_c4/)

 Facebook: [facebook.com/ledsc4.sa](https://www.facebook.com/ledsc4.sa)

 LinkedIn: [linkedin.com/company/ledsc4](https://www.linkedin.com/company/ledsc4)

 YouTube: [youtube.com/ledsc4](https://www.youtube.com/ledsc4)

 Pinterest: [pinterest.com/ledsc4](https://www.pinterest.com/ledsc4)

 Twitter: [twitter.com/ledsc4](https://www.twitter.com/ledsc4)

Light for
better living

LedsC4.com